

Installation guide

agardio. manager

**Multi-energy
data logger and server
HTG410H / HTG411H**

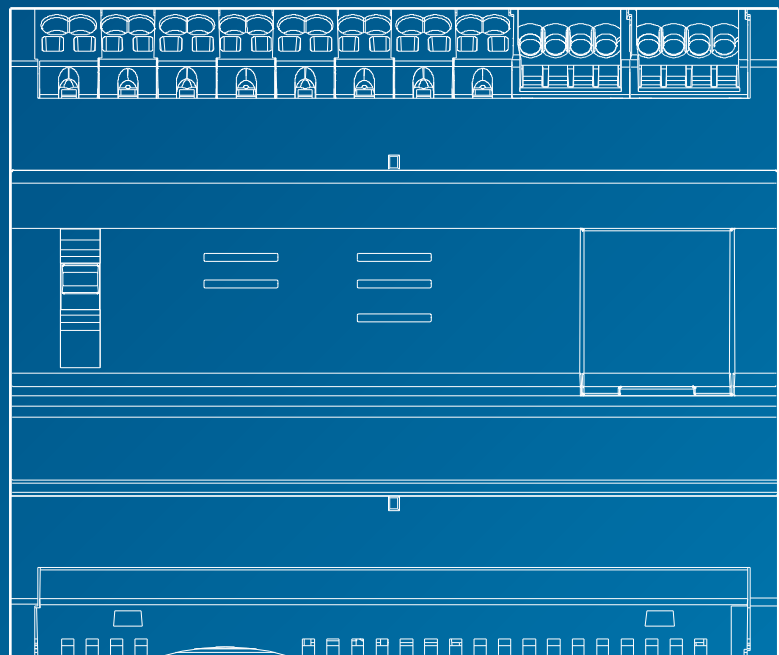

:hager

Installation guide

Page

01 Safety information	4
02 Short system presentation	5
03 Relevant standards	5
04 Mechanical installation	6
05 Modbus and RS485 specific wiring rules	8
06 Power supply and Input/output cabling	14
07 Devices installation and settings	21
08 Accessories	80
09 Acronyms	83

1. Safety information

This equipment must be mounted only by professionals.

The Hager Company shall not be held responsible for failure to comply with the instructions in this guide. Risk of electrocution, burns or explosion

- The device must be installed and serviced only by qualified personnel
- Prior to any work on the device, isolate the auxiliary power supply
- Always use an appropriate voltage detection device to confirm the absence of voltage
- Always supply the device with the correct rated voltage
- Failure to take these precautions could cause serious injuries.

For personnel and product safety please read the contents of this guide carefully before connecting. Check the following points as soon as you receive the HTG410H or HTG411H product:

- The packing is in good condition,
- The product has not been damaged during transport,
- The product reference number is conform to your order.

HTG411H = HTG410H multi energy data logger + μ SD card inserted.

Warning: without the micro card, the energy server does not start.

Inaccurate data results

- Do not incorrectly configure the software, as this can lead to inaccurate reports and/or data results.
- Do not base your maintenance or service actions solely on messages and information displayed by the software.
- Do not rely solely on data displayed in the software reports to determine if the system is functioning correctly or meeting all applicable standards and requirements.
- Do not use data displayed in the software as a substitute for proper workplace practices or equipment maintenance.

Failure to follow these instructions can result in death, serious injury, equipment damage, or permanent loss of data.

This user guide complete the installation instructions provided with the product delivery. You can download this installation guide from our website.

<http://hgr.io/r/htg410h>.



2. Short system presentation

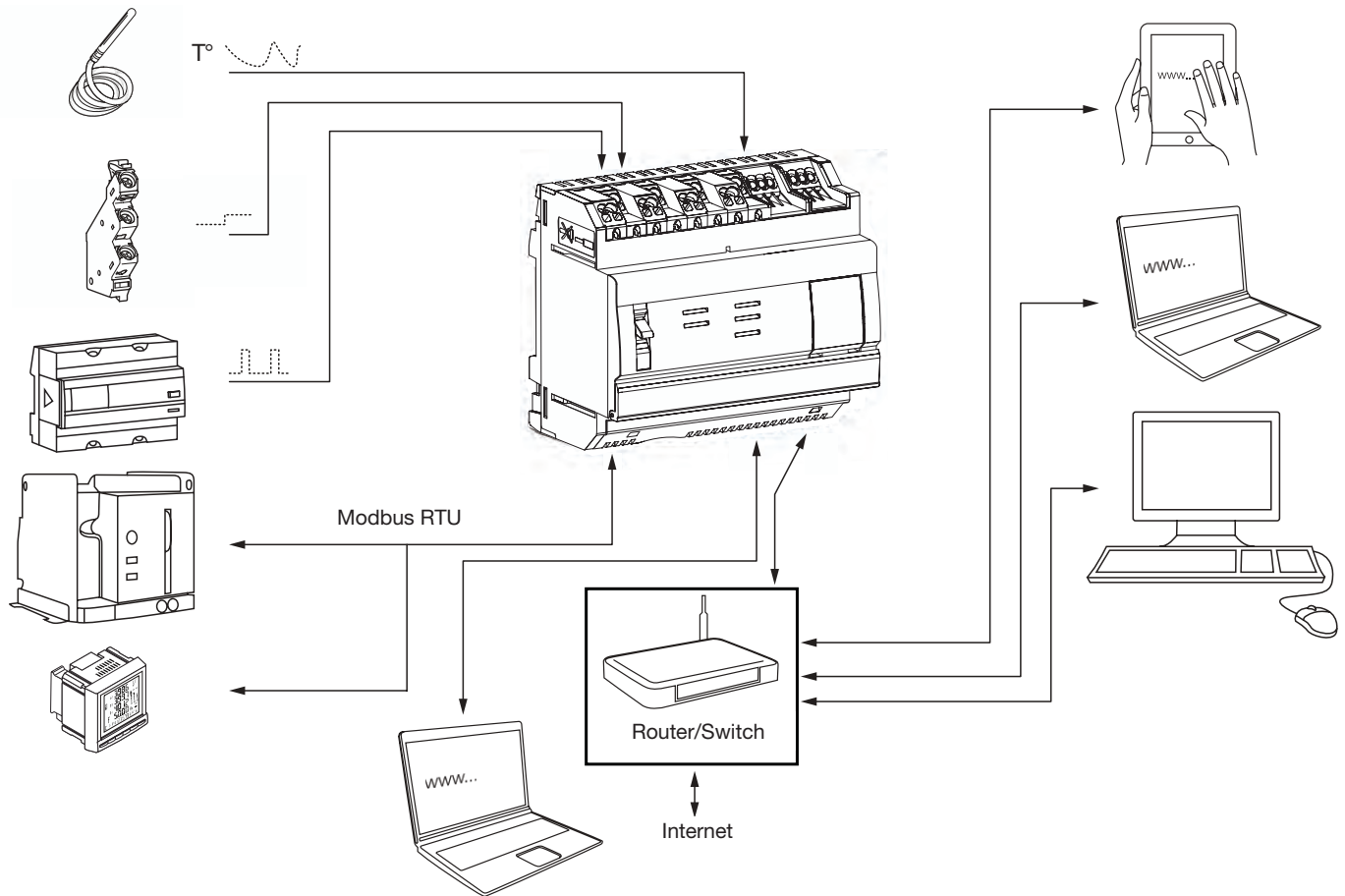

3. Relevant standards and technical characteristics

Document	Low-voltage directive	Issue
EN 60950-1	Information technology equipment – Safety – Part 1: General requirements	2006-04-14
EN 60950-1:2006/A11:2009	Information technology equipment – Safety – Part 1: General requirements	2009-03-06
EN 60950-1:2006/A1:2010	Information technology equipment – Safety – Part 1: General requirements	2010-03-12
EN 60950-1:2006/A12:2011	Information technology equipment – Safety – Part 1: General requirements	2011-02-25
EN 60950-1:2006/A2:2013	Information technology equipment – Safety – Part 1: General requirements	2013-08-23

Document	Electromagnetic compatibility directive	Issue
EN 61000-6-1	Electromagnetic compatibility (EMC) - Part 6-1: Generic standards - Immunity for residential, commercial and light industrial environments	2007-01-12
EN 61000-6-2	Electromagnetic compatibility (EMC) - Part 6-2: Generic standards - Immunity for industrial environments	2005-08-26
EN 61000-6-3	Electromagnetic compatibility (EMC) - Part 6-3: Generic standards - Emission standard for residential, commercial and light-industrial environments	2010-03-12
EN 61000-6-4 : 2007/A1:2011	Electromagnetic compatibility (EMC) - Part 6-4: Generic standards - Emission standard for industrial environments	2011-02-18

Document	Content	Issue
IEC 60364-8-1	Low-voltage electrical installations - Part 8-1: Energy efficiency.	2014-10-01
IEC 61557-12	Performance measuring and monitoring devices (PMD)	2001-08-15
IEC 62053-21	Static meters for active energy (classes 1 and 2)	2003-01-28
IEC 62053-22	Static meters for active energy (classes 0,2 S and 0,5 S)	2003-01-28
IEC 62053-31	Electricity metering equipment (a.c.) – Particular requirements.	1998-01-30

External safety extra low voltage power supply	24 V $\overline{\text{---}}$ (SELV) +/- 10%
Typical consumptions	7 VA
Ethernet network communication	Ethernet - TCP/IP - RJ45/100 base- T/IEEE 802.3
Modus network communication	RS485 Modbus RJ45
Operating temperature	-25° to + 70°C
Storage temperature	-55° to + 85°C
Humidity storage	95% max HR at 55°C
Binary digital input 1 and 2	15 to 27 V $\overline{\text{---}}$
Analog input 4-20 mA 1 and 2	Input impedance <300 Ohms
PT 100 input	2-wire probe - EN 60751 compliance
Binary digital output	5 ot 30 V $\overline{\text{---}}$ / ~ 10 mA to 3 A resistive dry contact
Number of relay cycles	100000
Analog output 0-10 V	Min impedance \geq 1kOhms
Power supply, digital inputs, digital output connection	0.75-2.5 mm ²
Analog inputs, analog output connection	0.2-1.5 mm ²
Degree of protection	IP20
Weight	290 g
Pollution degree	class 3
Altitude	2000 meters max.
Micro SD card	Class 10
USB port 1 (front face)	USB 2.0 Type A standard connector (Length 5m max)
USB port 2 (under the product)	USB 2.0 Type A standard connector (Length 5m max)

4. Mounting position installation

The energy server is a modular product designed for standard DIN EN 60175 symmetrical mounting rail 35mm. The product must be mounted in horizontal position, it is snapped directly onto the rail with selflocking spring. Two major points are to be taken into consideration in the selection of the location of the HTG410H:

- Install the energy server at mid-height or rather at the bottom of the enclosure to take advantage of the ambient temperature. The energy server should not be placed near devices that cause heating effects. It is recommended to keep a distance of 1 m between the floor and the antenna in order to ensure the correct functioning of the USB Wi-Fi dongle.
- Do not mount the energy server near the elements such as circuit breakers, contactors, busbars and power cables in order to avoid the disturbances due to EMC.

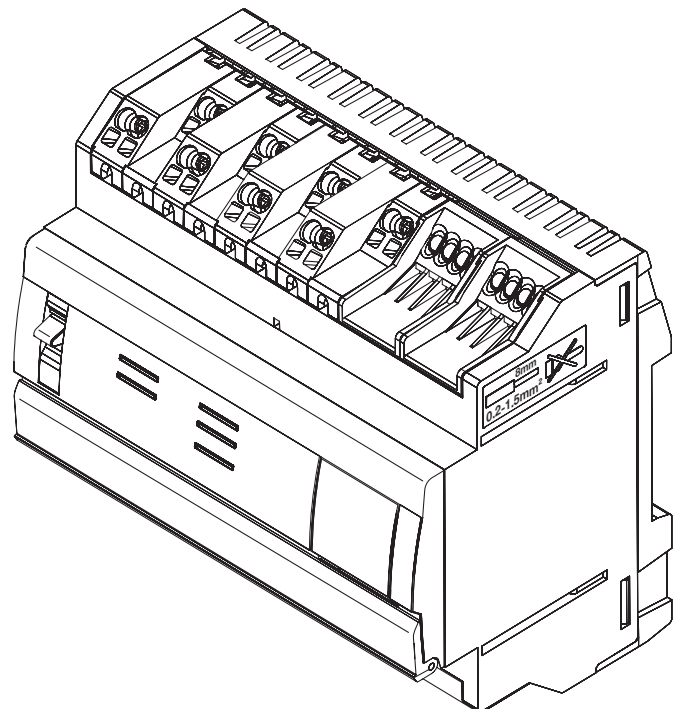



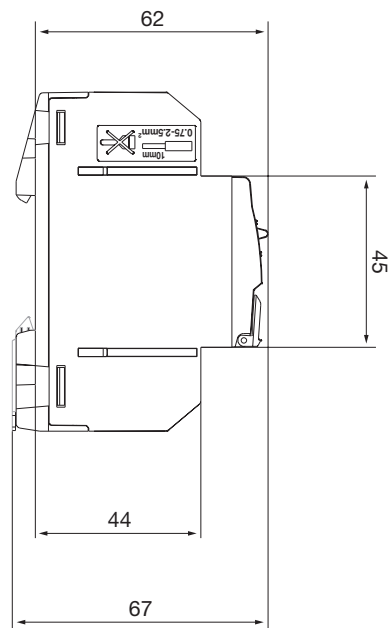
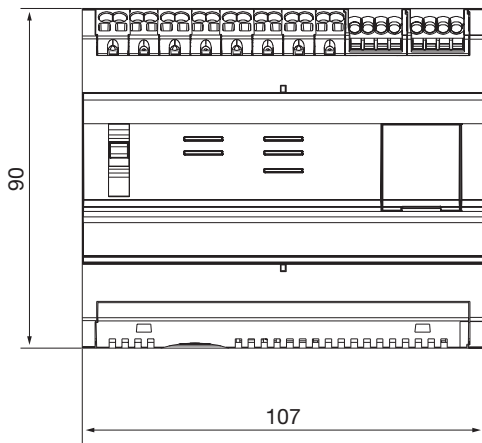

Mechanical dimensions

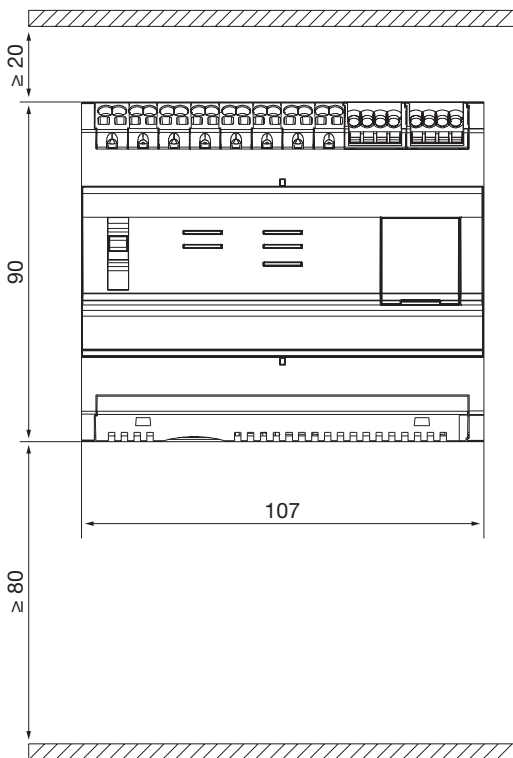

Recommended space for the energy server installation



Connections

	QC	QC small
 (mm ²)	0.75...2.5	0.2...1.5
 (mm ²)	0.75...2.5	0.2...1.5
 (mm²)	/	/
 (mm)	/	/
 (mm)	10	8

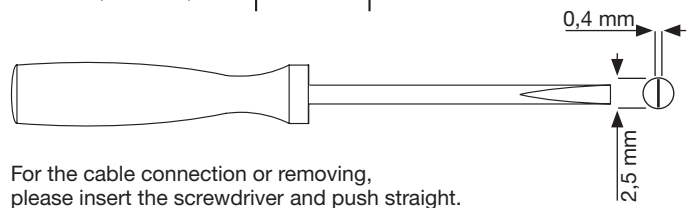

5. Modbus and RS485 specific wiring rules

Modbus protocol:

The Modbus over Serial Line Specification and Implementation Guide, published on www.modbus.org, defines the characteristics of the Modbus protocol over serial line.

Modbus is a serial communications protocol originally published by Modicon in 1979 for use with its programmable logic controllers (PLCs). Simple and robust, it has since become a de facto standard communication protocol. The development and update of Modbus protocols is managed by the Modbus Organization which is an association of users and suppliers of Modbus compliant devices. The Modbus serial line protocol is a Master-Slaves protocol. Only one master at the same time is connected to the bus, and one or several (247 maximum number) slaves are also connected to the same serial bus.

A communication is always initiated by the master. The slave will never transmit data without receiving a request from the master. The slaves will never communicate with each other. The master initiates only one transaction at the same time.

The master issues a request to the slave in two modes:

- In unicast mode, the master addresses an individual slave. After receiving and processing the request, the slave returns a message to the master. In that mode, a transaction consists of 2 messages: a request from the master, and a reply from the slave. Each slave must have a unique address (from 1 to 247) so that it can be addressed independently from other slaves.
- In broadcast mode, the master can send a message to all slaves. No response is returned to broadcast requests sent by the master. The broadcast requests are necessarily writing commands. All devices must accept the broadcast for writing function. The address 0 is reserved to identify a broadcast exchange.

The Query-Response Cycle (QRC)

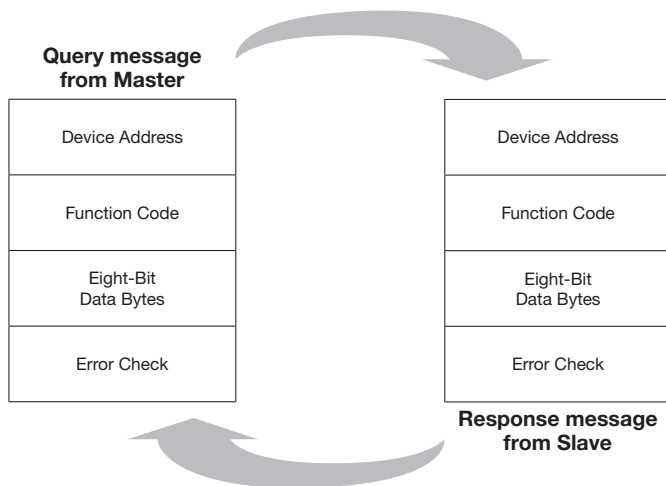

The Query: The function code in the query tells the addressed slave device what kind of action to perform. The data bytes contain any additional information that the slave will need to perform the function. The data field must contain the information telling the slave which register to start at and how many registers to read. The error check field provides a method for the slave to validate the integrity of the message contents.

The Response: If the slave makes a normal response, the function code in the response is an echo of the function code in the query. The data bytes contain the data collected by the slave, such as register values or status. If an error occurs, the function code is modified to indicate that the response is an error response, and the data bytes contain a code that describes the error. The error check field allows the master to confirm that the message contents are valid.

The serial Transmission Modes:

Two different serial transmission modes are defined: The RTU mode and the ASCII mode. It defines the bit contents of message fields transmitted serially on the line. It determines how information is packed into the message fields and decoded.

The transmission mode (and serial port parameters) must be the same for all devices on a Modbus serial line. Although the ASCII mode is required in some specific applications, interoperability between Modbus devices can be reached only if each device has the same transmission mode.

When devices communicate using the RTU (Remote Terminal Unit) mode, each 8-bit byte in a message contains two 4-bit hexadecimal characters. The main advantage of this mode is that its greater character density allows better data throughput than ASCII mode for the same baud rate. Each message must be transmitted in a continuous stream of characters. (only RTU mode is used in HTG410H)

The format (11 bits) for each byte in RTU mode is:

- Coding System: 8-bit binary

Bits per Byte:

- 1 start bit
- 8 data bits, least significant bit sent first
- 1 bit for parity completion
- 1 stop bit

Even parity is required; other modes (odd parity, no parity) may also be used.

The physical medium

A Modbus solution over serial line should implement an electrical interface in accordance with EIA/TIA-485 standard also known as RS485 standard. This standard allows point to point and multipoint systems, in a "two-wire configuration". In addition, some devices may implement a "Four-Wire" RS485-Interface.

In such a Modbus system, a master device and one or several slave devices communicate on a passive serial line.

On standard Modbus system, all the devices are connected on a trunk cable constituted by 3 conductors. Two of those conductors the two-wire configuration form a balanced twisted pair, on which bi-directional data are transmitted, typically at the bit rate of 9600 or 19200 bits per second, other baud rates may be possible : 1200, 2400, 4800, ... 38400 bps, 56 Kbps, 115 Kbps. A third conductor must also interconnect all the devices of the bus: the common.

Modbus basic diagram

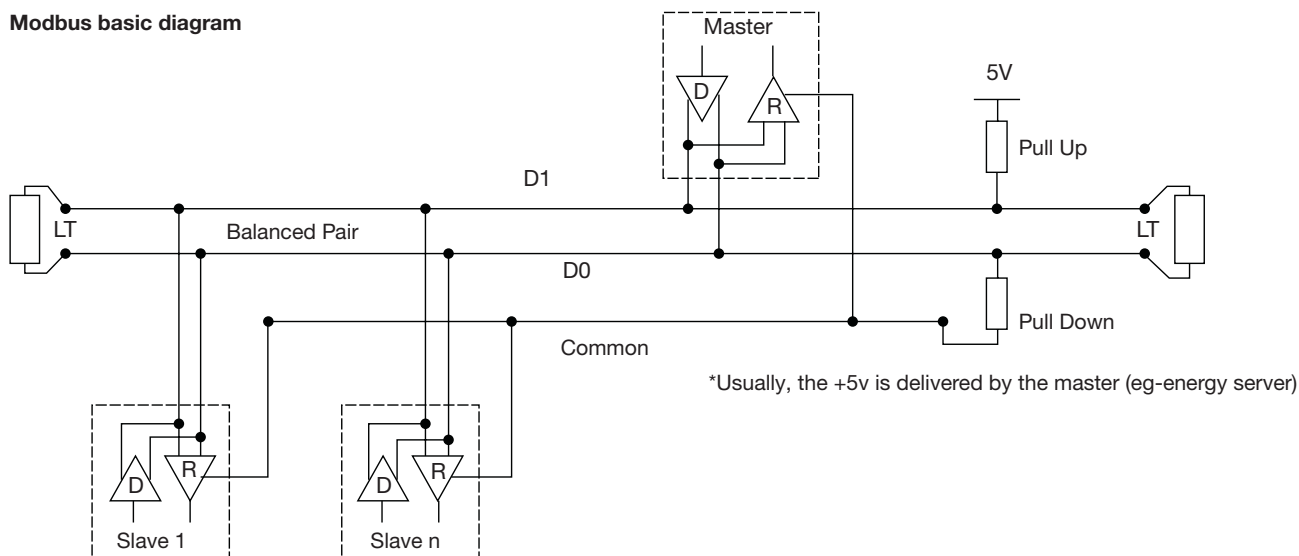

The EIA/TIA RS485

In 1983, the Electronic Industries Alliance (EIA) approved a new balanced transmission standard called RS-485. Finding widespread acceptance and usage in industrial and consumer applications, RS-485 has become the industry's interface workhorse. The RS-485 standard suggests that its nodes be networked in a daisy-chain, also known as bus topology. In this topology, the participating drivers, receivers, and transceivers are connected to a main cable trunk. The interface bus can be designed for full-duplex or half-duplex transmission.

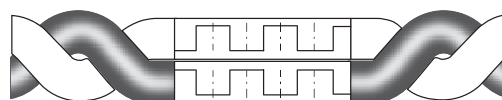

The twisting of the conductors into pairs ensures maximum interference suppression and increases the signal quality. Furthermore using screened twisted pair cable protects against external Electro Magnetic Interference (EMI).

Full-duplex

The full-duplex implementation requires two signal pairs, (four wires), and full-duplex transceivers with separate bus access lines for transmitter and receiver. Full-duplex allows a node to simultaneously transmit data on one pair while receiving data on the other pair.

All "A / D0" connections should be connected together using one conductor of the twisted pair cable, all "B / D1" connections should be connected together using the other conductor in the pair. The cable screen must be connected to the ground.

Half-duplex

In half-duplex, only one signal pair is used, requiring the driving and receiving of data to occur at different times. Both implementations necessitate the controlled operation of all nodes via direction control signals, such as Driver/Receiver Enable signals, to ensure that only one driver is active on the bus at any time.

There must be no more than two wires connected to each terminal, this ensures that a daisy chain or straight line configuration is used. A "Star" or a network with "Stubs (Tees)" is not recommended as reflections within the cable may result in data corruption.

The master will start the conversation with a Query addressed to a specific slave, the master will then listen for the slave's response. If the slave does not respond within a pre-defined period set by control software in the master, the master will abandon the conversation.

Daisy Chained Connection (Correct)

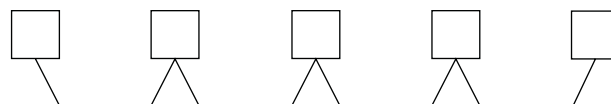

Bus loading, maximum number of devices

To estimate the maximum number of bus loads possible, the RS-485 standard specifies a hypothetical term of a unit load (UL), which represents a load impedance of approximately 12kΩ. With this consideration, up to 32 of these unit loads can be placed on the same network.

Stub Connection (Wrong)

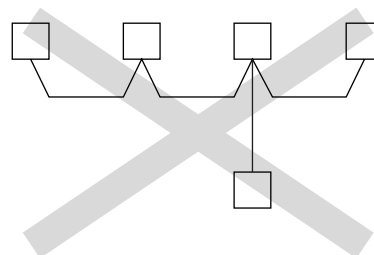

Device connection

The system is called balanced, because the signal on one wire is ideally the exact opposite of the signal on the second wire. If one wire is transmitting a high, the other wire will be transmitting a low, and vice versa.

Characteristic impedance of twisted-pair wire
Depending on the geometry of the cable and the materials used in the insulation, twisted-pair wire will have characteristic impedance associated with it that is usually specified by its manufacturer. The RS-485 specification recommends, but does not specifically dictate, that this characteristic impedance be 120Ω.

Although RS-485 can be successfully transmitted using multiple types of media, it should be used with wiring commonly called twisted pair. As its name implies, a twisted pair is simply a pair of wires of equal length and twisted together.

Termination resistors

Because of the high frequencies and the distances involved, proper attention must be paid to transmission-line effects. A terminating resistor is placed at the extreme end or ends of the cable. It is important that the line be terminated at both ends since the propagation is bi-directional.

The value of the terminating resistor is ideally the same value as the characteristic impedance of the cable.

When the termination resistance is not the same value as the characteristic impedance of the wiring, reflections will occur as the signal travels down the cable.

Although some reflections are inevitable due to cable and resistor tolerances, large enough mismatches can cause reflections big enough to cause errors in the data.

Each line termination must be connected between the two conductors of the balanced line.

To summarize, the different cabling points to respect for the bus are:

- Screened twisted pair cable must be used, minimal cross section 0,25mm² or AWG 24, 2 pairs, 120Ω characteristic impedance.

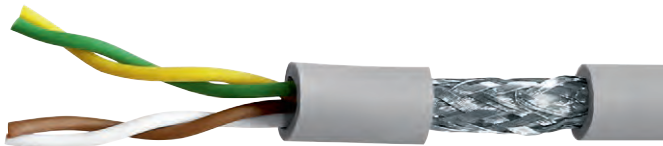

(Picture no contractual)

- Length of the bus, maximal 1200m if using 0,34mm² or AWG 22 cable or greater.
- The cable must be terminated at each end with a 120Ω, 1/4 W (or greater) resistor.
- Daisy chained connection (only 1 short stub allowed on the bus, maximal length 30cm)
- Maximum 32 devices (1 master + 31 slaves)

The following wiring rules must be respected in order to 410H reduce disturbance due to EMC on the behavior of the HTG410H:

- Keep a distance as large as possible between the communication cable and the power or control cables, minimum 30cm.
- Cross over the Ethernet cable and the power cables at right angles, if necessary.
- Install the communication cables as close as possible to the grounded plate.
- Do not bend or damage the cables. Respect the minimum bending radius of the cable.
- The cable shield must be connected as short as possible to a protective ground.
- Wire the bus between each connector directly, without intermediate terminal blocks.

Diagram with 2 wires connection devices

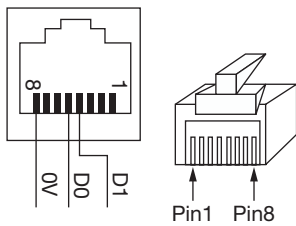
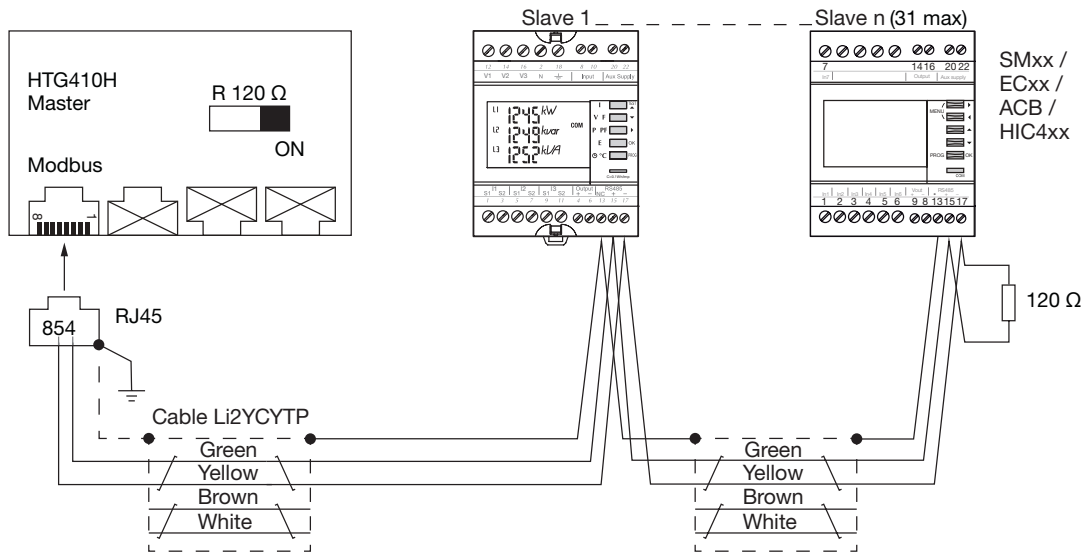
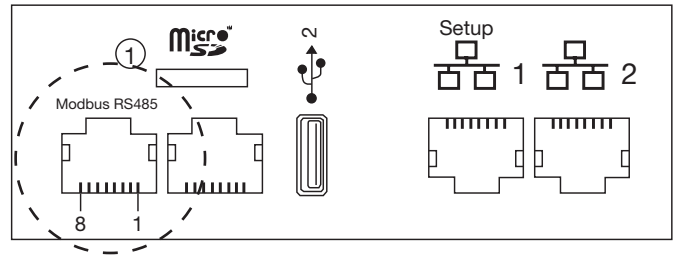
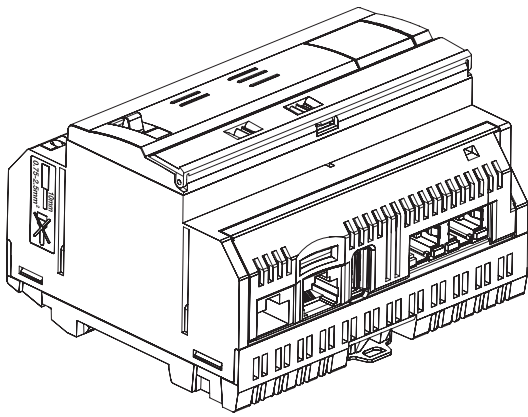

Detail for the pin position at RJ45 jack and plug respectively.

Pin 4 = D1 or B/B' or (+)	Green conductor
Pin 5 = D0 or A/A' or (-)	Yellow conductor
Pin 8 = Common or C/C' or (0VL)	Not used in this configuration

Remarks:

- Line termination on the master, energy server HTG410H (R=120 Ω = on) and on the end of the bus.

Note, the SM102E, SM103E and HIC4xx have an integrated resistance, if the device (SM102E, SM103E, HIC4xx) is located at the termination of the Modbus line, the 2 dip-switches on the communication module should be set on the "ON" position for the resistance activation.

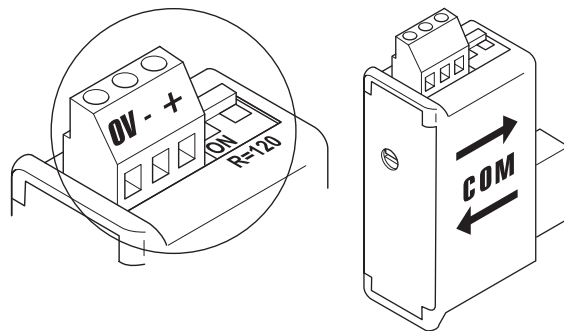

- Use always the same pair (green-yellow) for the cabling, cable reference HTG485H.
- Cable shield grounded only at the beginning of the bus, by using the shielded connector with earth cable, reference HTG465H.



Diagram with 3/2 wires connection devices

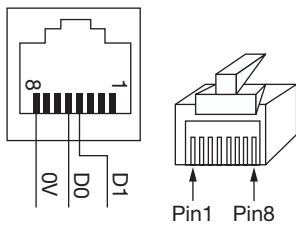
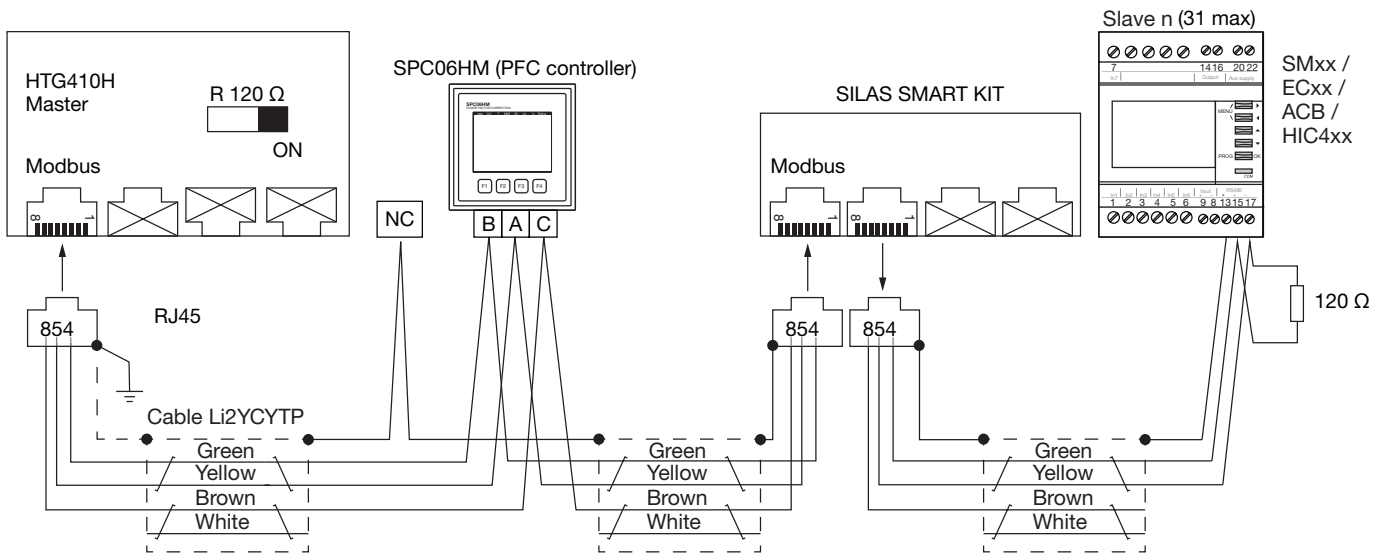
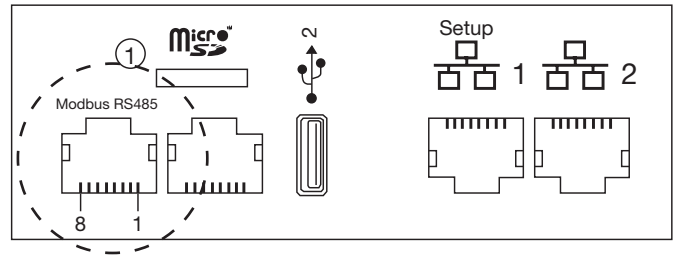
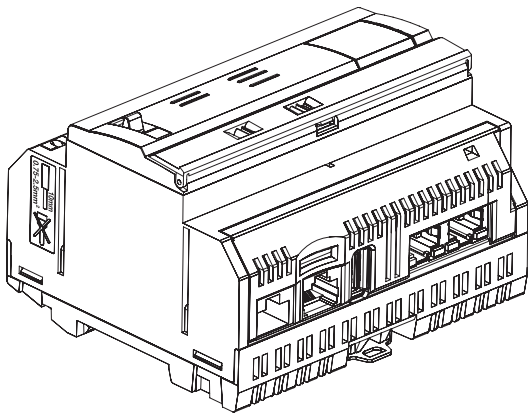

Detail for the pin position at RJ45 jack and plug respectively.

Pin 4 = D1 or B/B' or (+)	Green conductor
Pin 5 = D0 or A/A' or (-)	Yellow conductor
Pin 8 = Common or C/C' or (0VL)	Brown conductor

Remarks:

- Line termination on the master, energy server HTG410H (R=120 Ω = on) and on the end of the bus.

Note, the SM102E, SM103E and HIC4xx have an integrated resistance, if the device (SM102E, SM103E, HIC4xx) is located at the termination of the Modbus line, the 2 dip-switches on the communication module should be set on the "ON" position for the resistance activation.

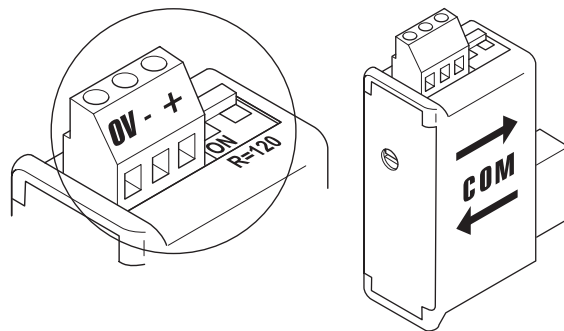

- Use always the same pair (green-yellow) for the D1/D0 cabling and the brown conductor for the common, cable reference HTG485H.
- Cable shield grounded only at the beginning of the bus, by using the shielded connector with earth cable, reference HTG465H.



6. Power supply and Input / Output cabling

6.1 Power supply

The HTG410H requires a 24 VDC $\pm 10\%$ voltage supply installed near it. It must be Safety Extra Low Voltage (SELV) type, with galvanic isolation between the power supply input (AC voltage) and the power supply output (DC voltage). The rated AC voltage of the power supply input must be 240 VAC.

Here under a global overview for the cabling possibilities and power supply preconditions.

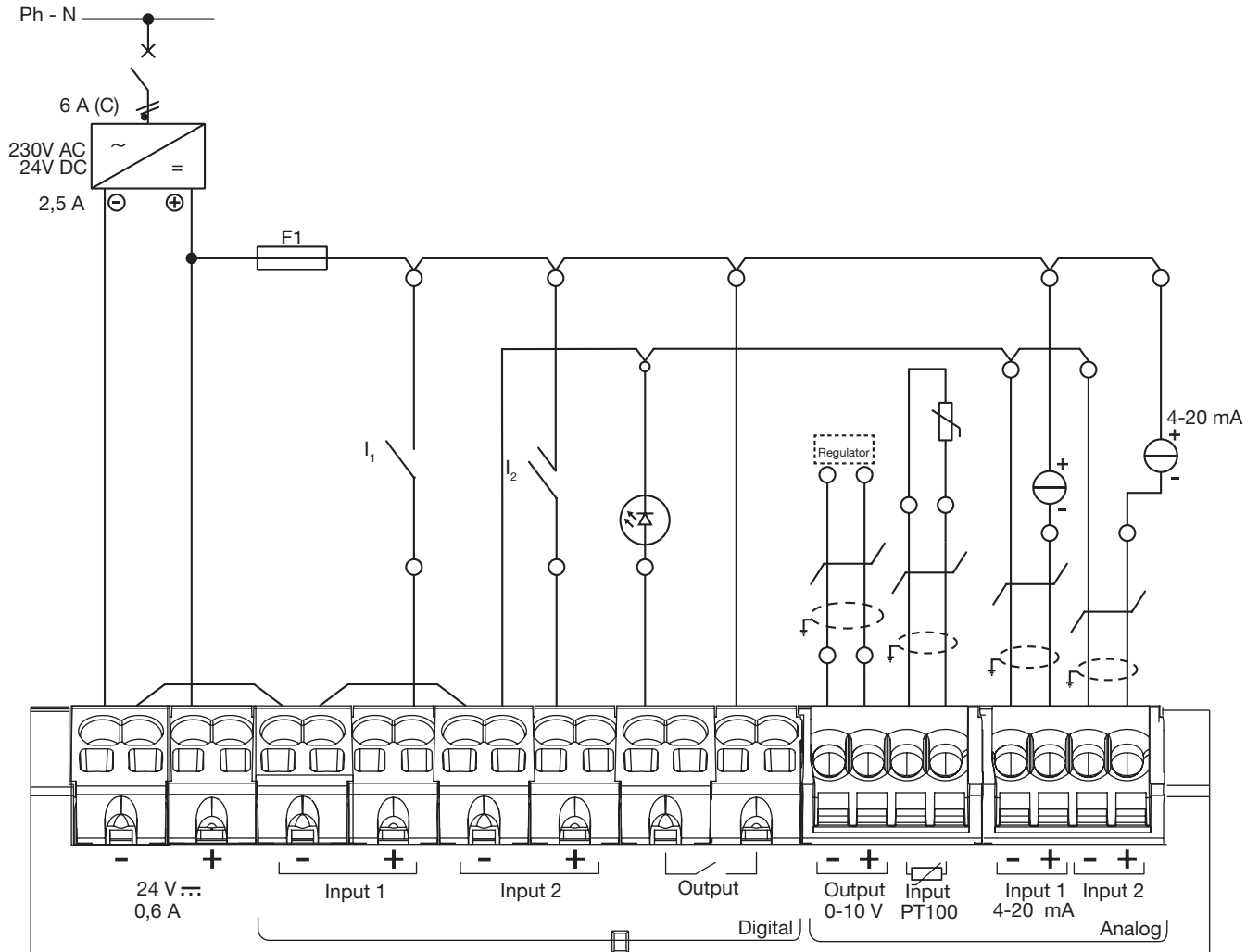

Recommendations:

You should protect the I/O cabling, in order to ensure the bus communication in the event of a short-circuit on the actuator side. F1: miniature fuse 5/20, rating 2,5A F or lower, (according to the load). The wiring for the I/O information's should be done with screened twisted pair cable.

Remember:

For the cable connection or removing, please insert the screwdriver (0.4 x 2.5) and push straight.

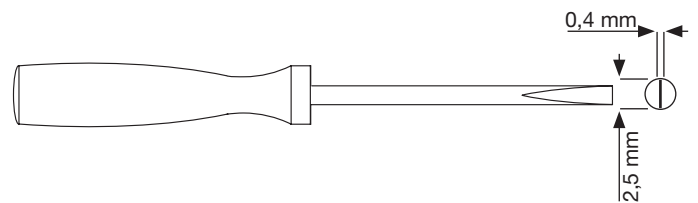



6.2 Digital input 1 & 2

The energy server has 2 configurable digital inputs that can be used to read states (On-Off) or pulse counting.

Length of cable	Up to 100 m
Minimum current in ON-state	10 mA
Maximum current in ON-state	27 mA
Supply voltage	24 VDC
Pulse duration	30 ms ≤ tOn ≤ 120 ms tOff ≥ 30 ms
Applicable standard	IEC 62053-31E1, class A

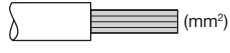
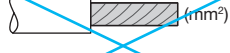
Connections

	QC
	0.75...2.5
	0.75...2.5
	/
	
	10

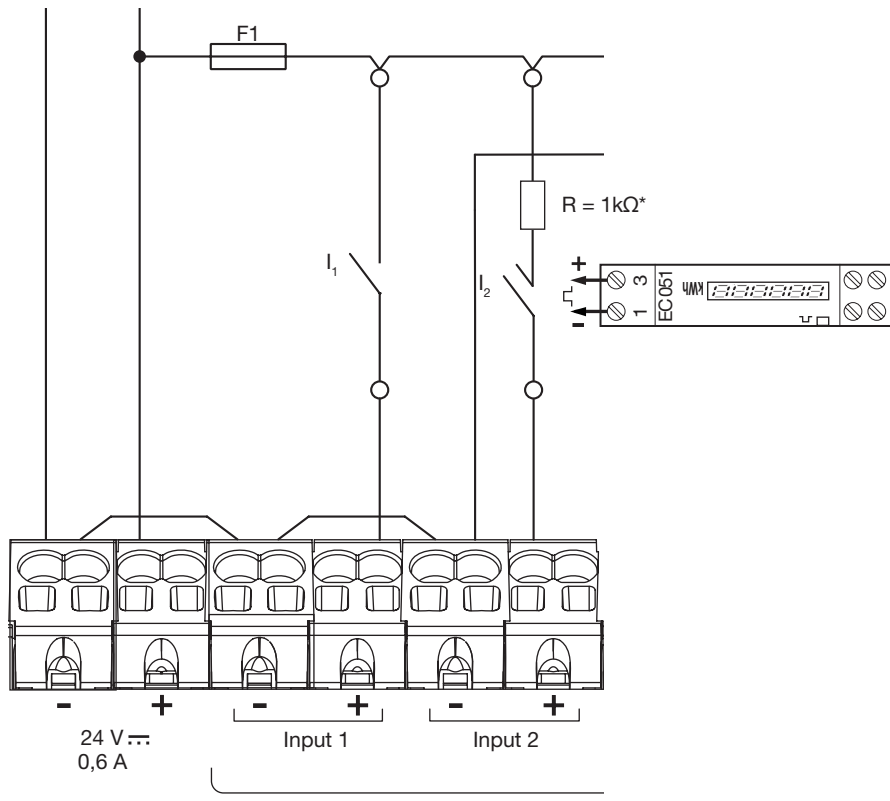

Application example

Input 1: I1 state contact (ACB, MCCB position...)

Input 2: pulse contact from EC051.

The energy server is able to read output pulses of any Hager products, or any manufacturer compliant with the IEC 62053-31E1, class A standard.

Single phase counter direct 32A products EC051.

Single phase counter direct 63A products EC150, EC152 and EC154M.

Three phases counter direct 63A products EC350 and EC352.

Three phases counter direct 100A products EC360, EC362, EC364M and EC365B.

Three phases counter via current transformer product EC370 and EC372.



*Note: if you connect a EC051, you must wire a 1kΩ resistor (not supplied) in series. (Resistor not necessary for the EC15x, EC3xx)

6.3 Digital output

The energy server has 1 configurable alarm output (NO contact)

Length of cable	Up to 10 m
Mechanical endurance	100000 cycles
Rated voltage	5 - 30 VDC / AC
Rated current (max)	3 A
Min contact load	5 VDC, 10 mA

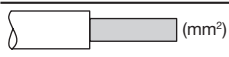
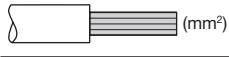
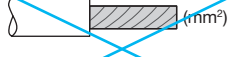
Connections

	QC
 (mm ²)	0.75...2.5
 (mm ²)	0.75...2.5
 (mm ²)	/
 (mm)	10

Application example:

Alarm light

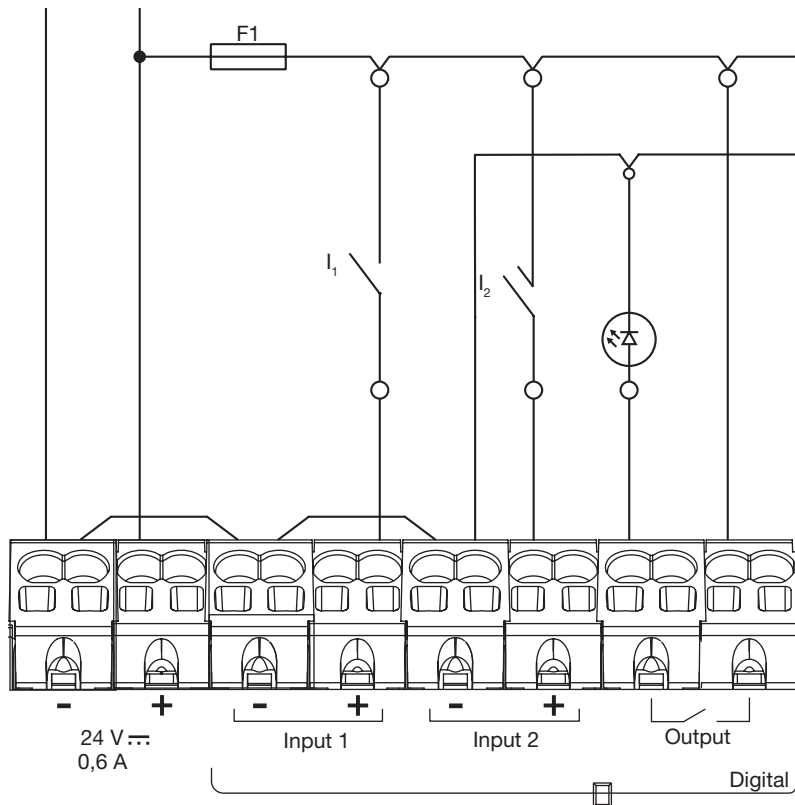





6.4 Analog output 0/10V

The energy server is able to provide a set-point for any regulator connected to its 0 – 10V output.

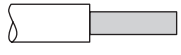
Length and cross section	Up to 10 m max, 0,25 mm ² minimum
Type of cable	Screened twisted pair cable
Load impedance	>=1 kΩ
Accuracy	± 0.5% off full scale value
Applicable standard	EN 61131-2

Connections

	QC small
 (mm ²)	0.2...1.5
 (mm ²)	0.2...1.5
 (mm²)	/
 (mm²)	/
 (mm)	8

Application example:

Regulator (set point 0-10V)

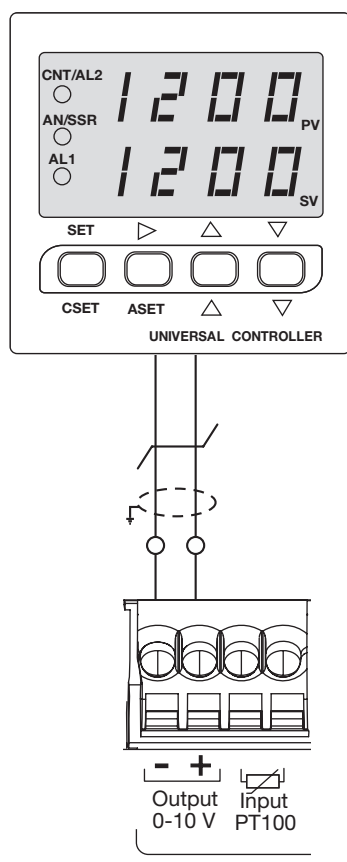



6.5 Pt100 temperature device

The energy server allows the internal cabinet or room temperature measure through a resistance temperature device PT100.
Reference HTG445H (cable 3 meters)

Length and cross section	Up to 3 m max, 0,25 mm ² minimum
Type of cable	Screened twisted pair cable
Reading frequency	1 Hz
Amplitude	-35°C to 100°C
Accuracy	± 0.7°C
Tolerance class	B
Applicable standard	EN 60751

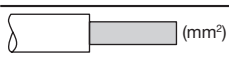
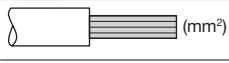
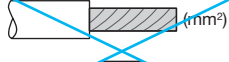
Connections

	QC small
 (mm ²)	0.2...1.5
 (mm ²)	0.2...1.5
 (mm²)	/
	/
 (mm)	8

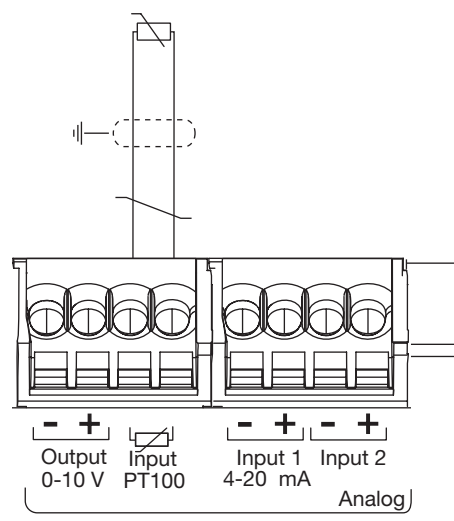

6.6 Current loops 4-20 mA

Two 4-20 mA DC current loops are available on the energy server. The two-wire 4-20 mA control loops, are used to convert various process signals representing flow, speed, position, level, temperature, pressure, pH, etc., to 4-20 mA DC. The use of 4 mA as the starting point for the transmitted signal is useful in trouble-shooting, as signal integrity is verified with 0% of input and output signal. A failed current loop due to a lead break or open device can be immediately discerned as zero current flow, which is a fail-safe level outside of the signal range.

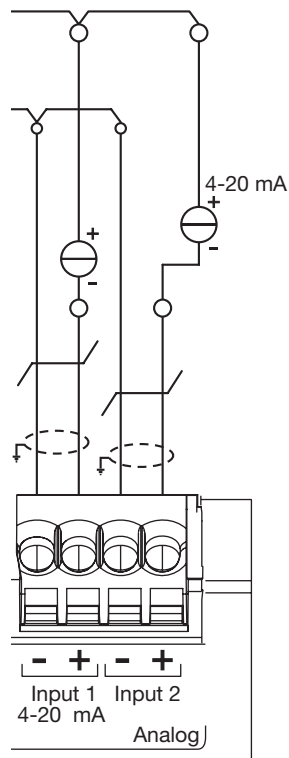
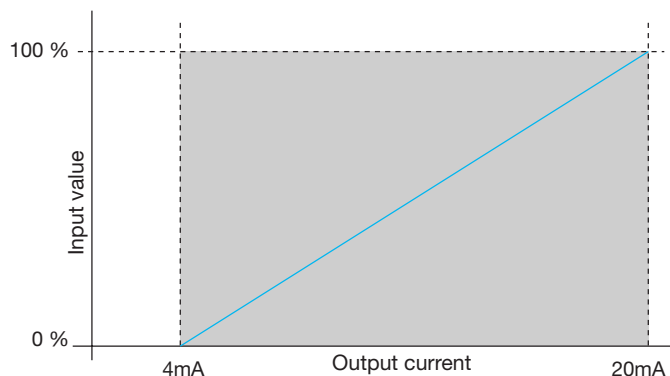

Length and cross section	Up to 10 m max, 0,25 mm² minimum
Type of cable	Screened twisted pair cable
Reading frequency	1 Hz
Accuracy	± 0.5% of the whole scale
Applicable standard	EN 61131-2

Connections

	QC small
	0.2...1.5 (mm ²)
	0.2...1.5 (mm ²)
	/
	/
	8 (mm)

7. Devices installation and settings

All the Modbus devices connected together on the same line must be set with the same:

- Communication transfer rate
- Parity
- Stop bit

The table resumes the different possibilities or restriction imposed by the products connected on the Modbus line.

	Address	Transfer rate
HTG410H	/	9.6 – 38.4
SM10x		4.8 – 38.4
ECx		4.8 – 38.4
EC700		9.6 – 38.4
SPC06HM		4.8 – 19.2
ACB	1 to 31	4.8 – 19.2
HIC4xxE		9.6 – 38.4
Silas		9.6 – 38.4

If the selected parity is "Even" or "Odd" the stop bit must be 1.
If "No" parity selected, the stop bit must be 2.

Our recommendation for the bus configuration :

Transfer rate	Parity	Stop bit
19200 Bauds	Even	1



Note

The energy server HTG410H is configured as master by default on the Modbus line, and doesn't need an address.

7.1 Multifunctional metering Modbus device

7.1.1 SM101C

- 7.1.2 SM102E if fitted with the SM210 – Modbus RS485 module,
- 7.1.3 SM103E if fitted with the SM211 – Modbus RS485 module,

7.2 Modbus energy meters

- 7.2.1 ECR140D
- 7.2.2 ECR180X, ECR3XXX / ECA180X, ECA3XXX
- 7.2.3 EC366 / EC367M
- 7.2.4 EC376
- 7.2.5 EC377M

7.3 Electrical pulses concentrator: EC700

7.4 Module de Communication : HTC3x0H

7.5 Power Factor Correction Controller: SPC06HM

7.6 Air Circuit Breaker (A.C.B) with option communication

7.7 Automatic Transfer Switch (A.T.S) HIC4xxE

7.8 Fusegear Silas smart kit

7.1 Multifunctional metering Modbus device

7.1.1 Commissioning the SM101C

Make sure that the power supply and the different connections are properly connected before you switch on the device.
If you have a doubt, please consult the SM101C instruction manual.

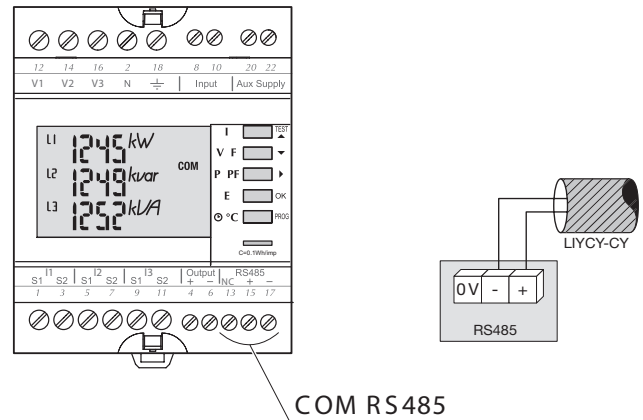

If the metering device is integrated into the RS485 daisy chain network as first or terminal device, the resistor 120 Ω provided must also be connected between the terminals 15/17 "+" and "-".

7.1.1.1 Access to programming mode: pass code 100

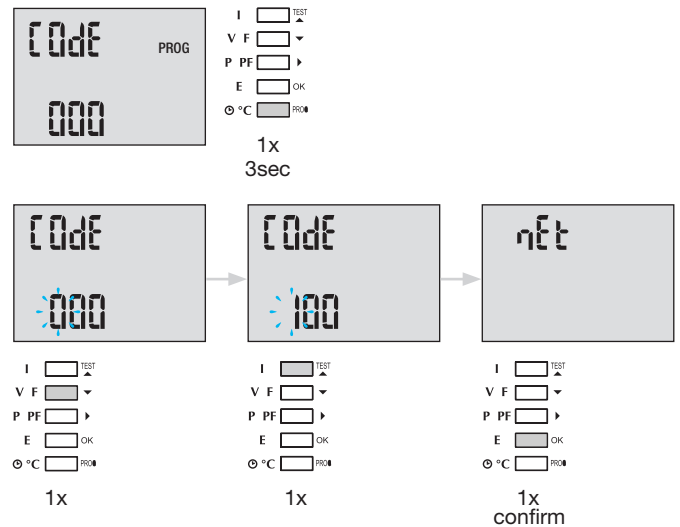

After opening programming mode, press button ▲▼ (top or bottom) repeatedly to select the desired menu.

Advice: Set or check at least these 2 configurations: network type and current transformer as following. (For the complete programming, please refer to the SM101C instruction manual)

7.1.1.2 Network type (first menu, when opening programming mode)

Example: NET = 3NBL



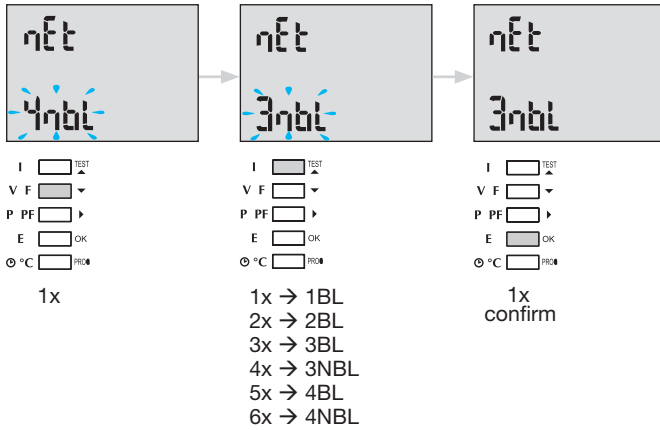

7.1.1.3 Current transformer CT

Press button ▲ to access this configuration item. The default value for the secondary side is 5 A.

Example: Transformer ratio CT = 1200 / 5

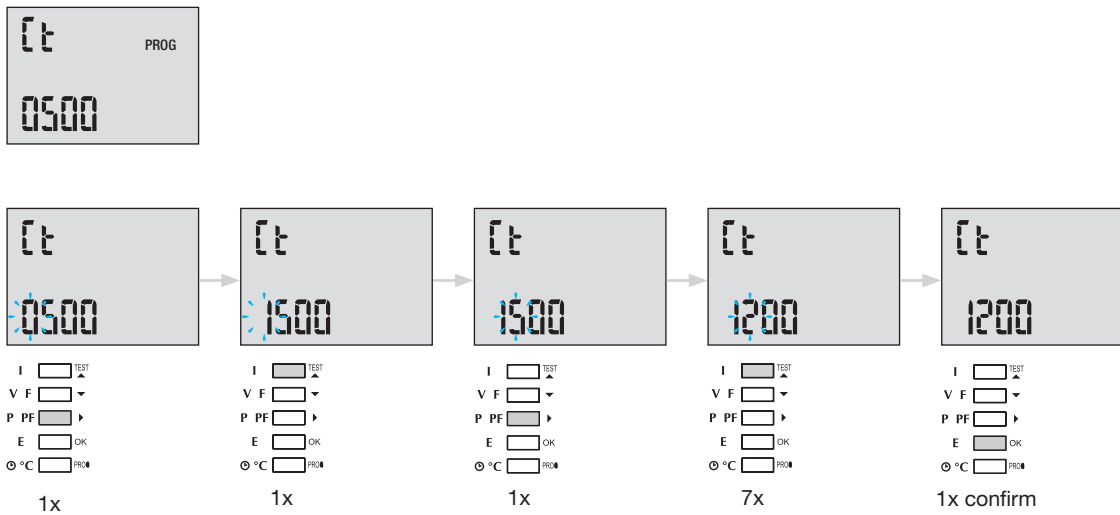

7.1.1.4 Modbus configuration

7.1.1.4.1 Communication address

Press button ▲ to access this configuration item.

Example: COM Adr = 115

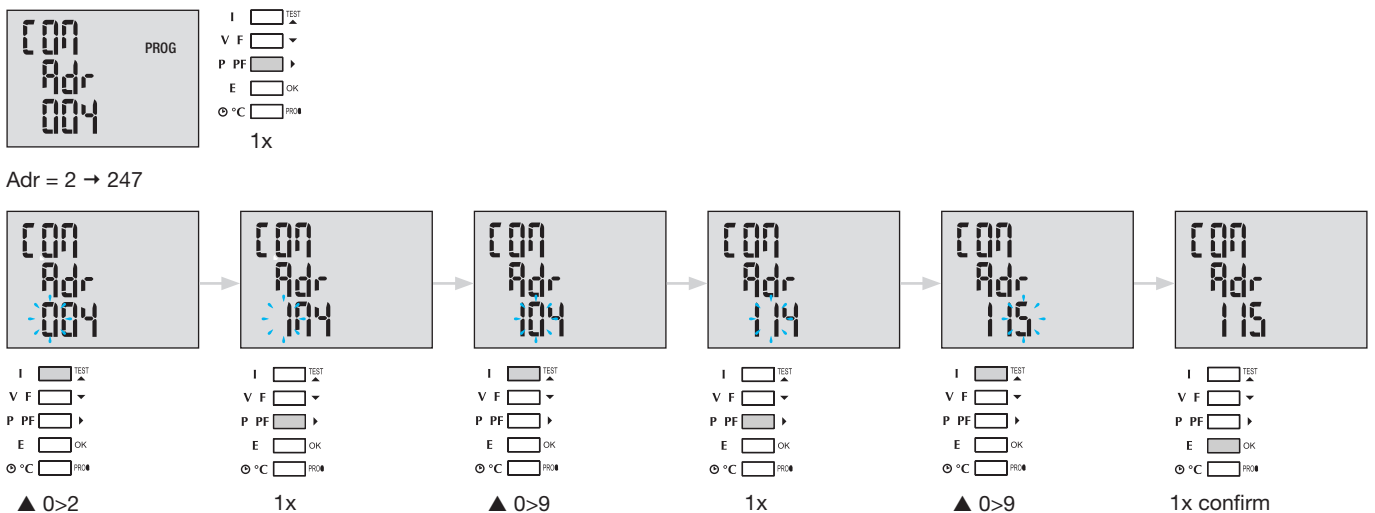

7.1.1.4.2 Setting the transfer rate

Press button ▲ to access this configuration item.

Example: COM bdS = 4,8

1x

1x (2,4)
2x (4,8)
3x (9,6)
4x (19,2)
5x (38,4)

1x confirm

7.1.1.4.3 Setting the parity

Press button ▲ to access this configuration item.

Example: COM PAR = Odd

1x

1x (Odd)
2x (Even)
3x (nO)

1x confirm

7.1.1.4.4 Setting the stop bit

Press button ▲ to access this configuration item.

Example: COM StOP = 2

1x

1x (1)
2x (2)

1x confirm

7.1.1.5 To quit and save programming

Prog 3 sec.

When the communication is established between the master and the slave, the activity indicator "COM" is blinking on the display.

7.1.1.6 Function test for the electrical wiring connections

During testing, device SM101C must be supplied with current and voltage to all connections. Testing requires a power factor of the installation between 0.6 and 1. If the power factor of the installation falls outside this range, the test cannot be performed. In the case of 4 BL / 3 BL / 2 BL / 1 BL only the connection of the current transformer is tested. In the case of 4 NBL and 3 NBL the connection as a whole is controlled.

Error	Error description
Err0	There is no error
Err 1 / 2 / 3	Reversed polarity of current transformer on phase 1 / phase 2 / phase 3
Err4	Reversed polarity of voltage between V1 and V2
Err5	Reversed polarity of voltage between V2 and V3
Err6	Reversed polarity of voltage between V3 and V1



7.1.1.6.1 Example of test without error

Press and hold button "Test" for at least 3 seconds to start testing the connections. If, as shown in the example, no error is found, press and hold button "Test" again for at least 3 seconds to return to display mode.

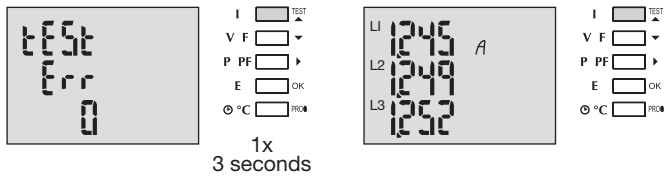

7.1.1.6.2 Test with error detection

Existing errors Err1 / 2 / 3 can be resolved automatically by selecting the corrective function, this eliminates the need for re-wiring.

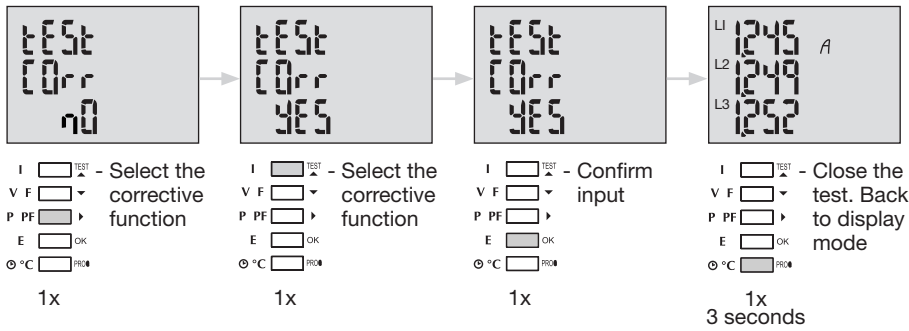
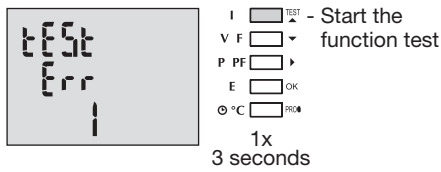

For the Err 4 / 5 / 6 the modification must be performed manually by correcting the voltage connections.

7.1.2 Commissioning the SM102E

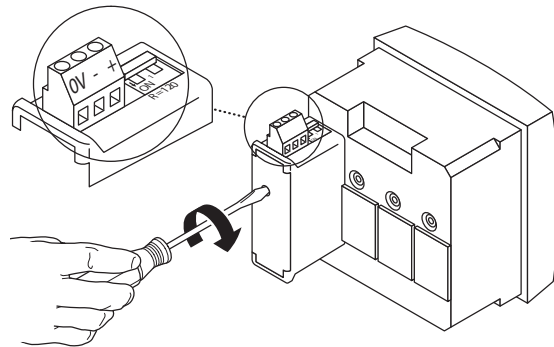
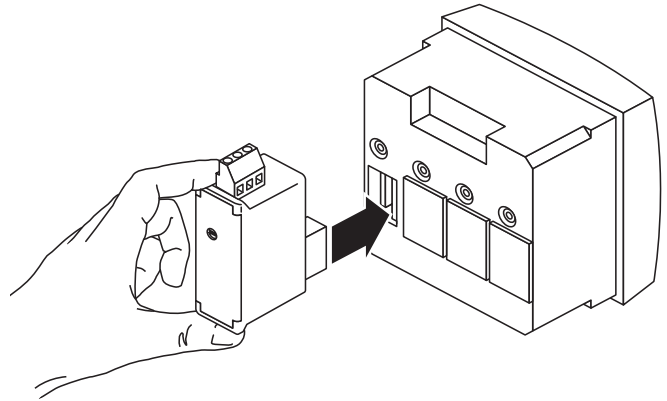
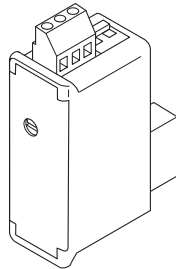
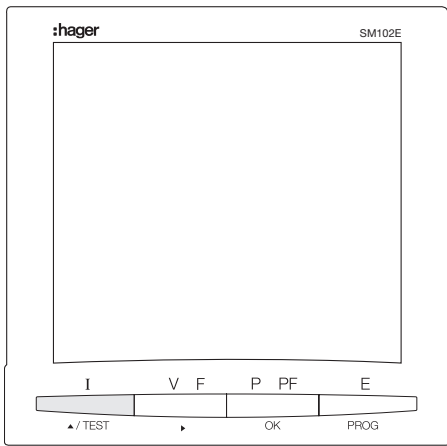

Warning

Before switching on the SM102E, the Modbus e SM210 is too fitted onto the back of the power meter in one of the two positions provided, and to be wired.

Make sure that the power supply and the different connections are properly connected. If you have a doubt, please consult the SM102E instruction manual.

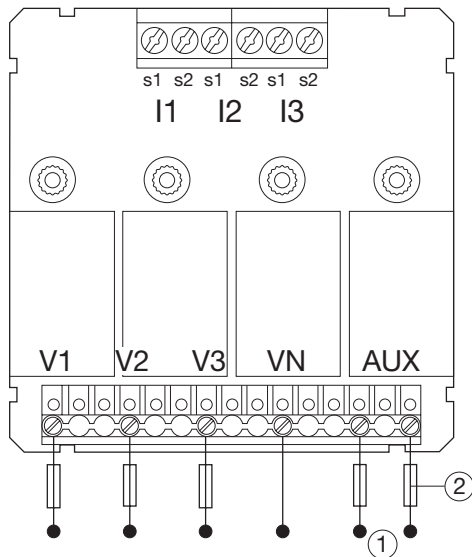

If the device is located at the beginning or termination of the Modbus line, the 2 dip-switches on the communication module must be set on the "ON" position for the resistance activation.

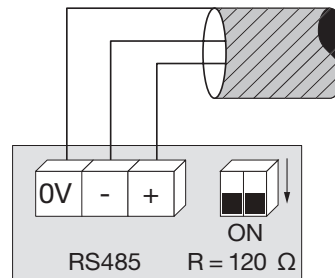

0V terminal is used for the cable shield connection and not common.

7.1.2.1 Access to programming mode: pass code 100

Press and hold button "PROG" for at least 3 seconds to access the configuration level.
 "100" is configured as code by default.

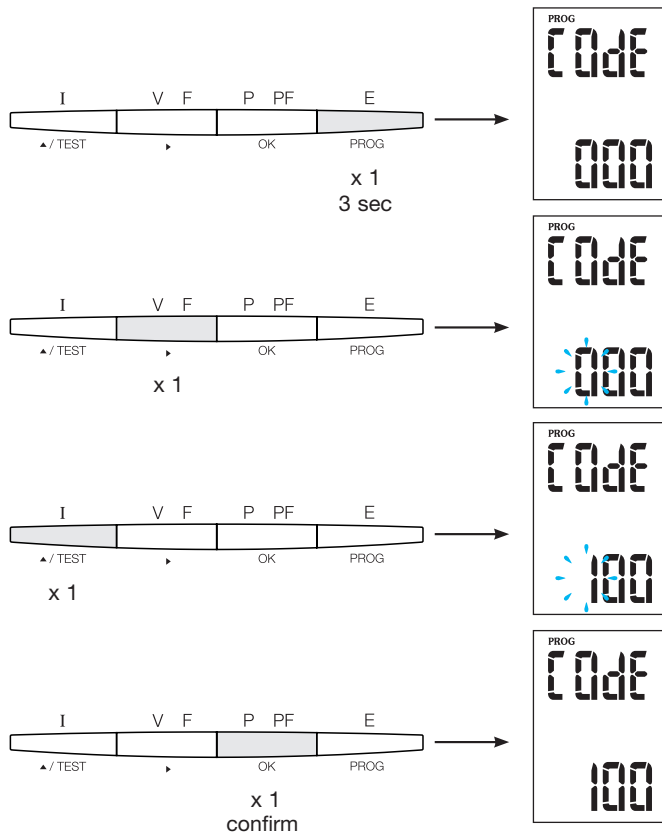

7.1.2.2 Network type

(first menu, when opening programming mode)
 The example shows the setting for a three-phase network with asymmetric load.

NET = 3NBL

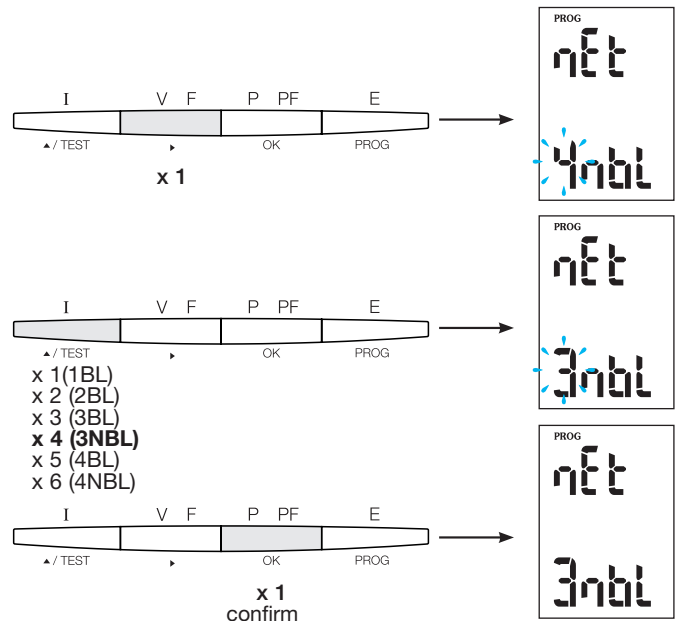

Advice

Set or check at least these 2 configurations: network type and current transformer as following. (For the complete programming, please refer to the SM102E instruction manual)

7.1.2.3 Current transformer CT

Press button ▲ to access this configuration item.
The multifunctional metering device SM102E is set by default to 5A on the secondary side.

Example: Transformer ratio CT = 1200 / 5 A

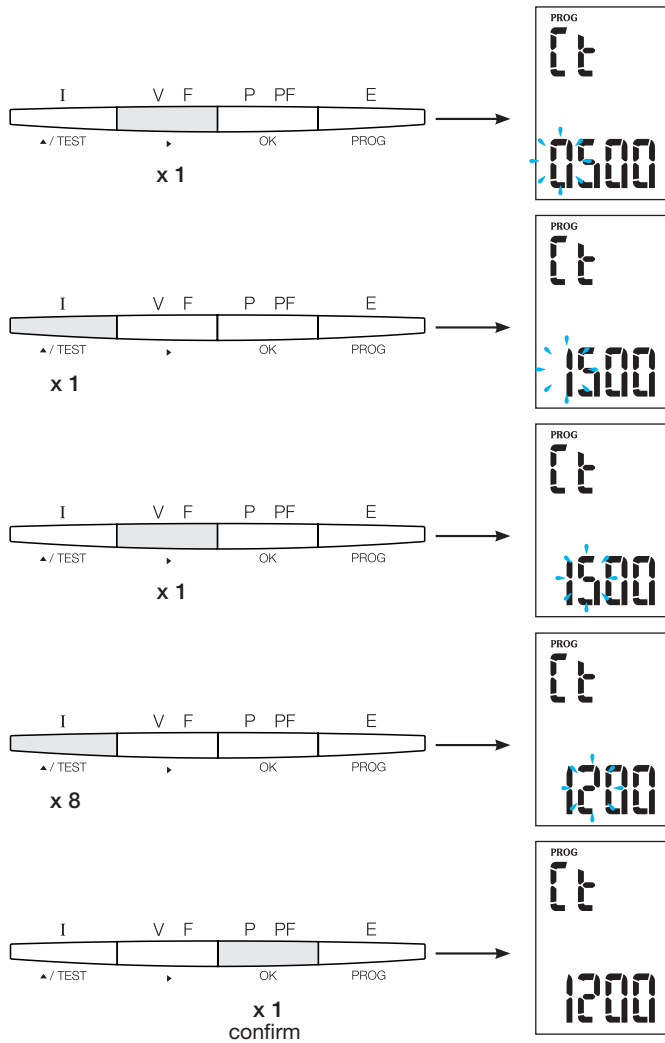

7.1.2.4 Modbus configuration

7.1.2.4.1 Communication address

Press button ▲ to access this configuration item.

Example: Adr = 10

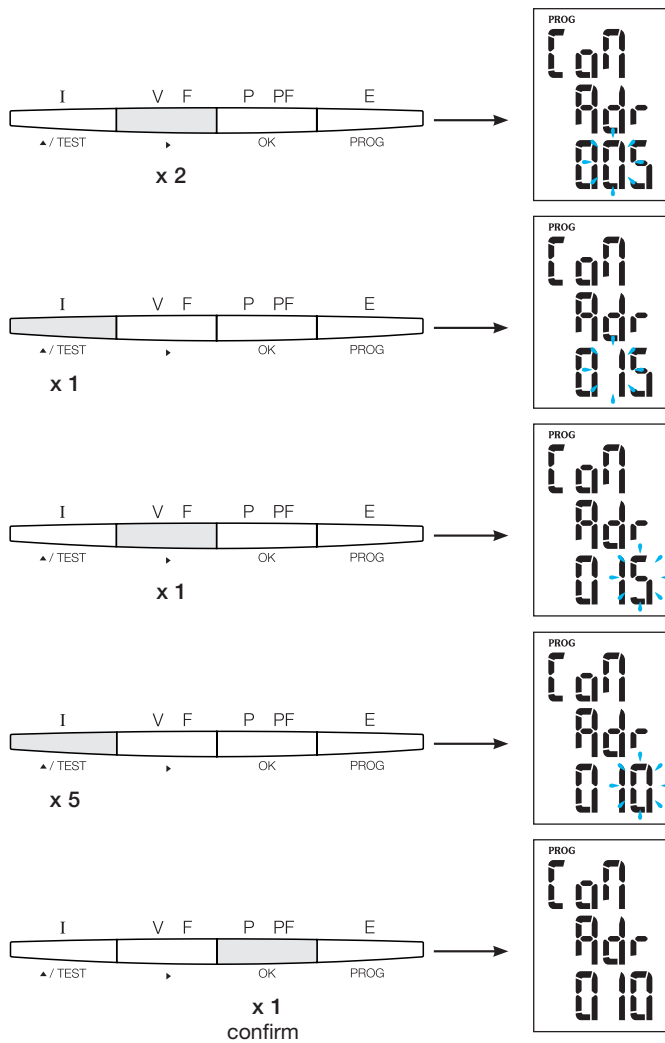

7.1.2.4.2 Setting the transfer rate

Press button ▲ to access this configuration item.

Example: **bdS = 38.4 kbauds**

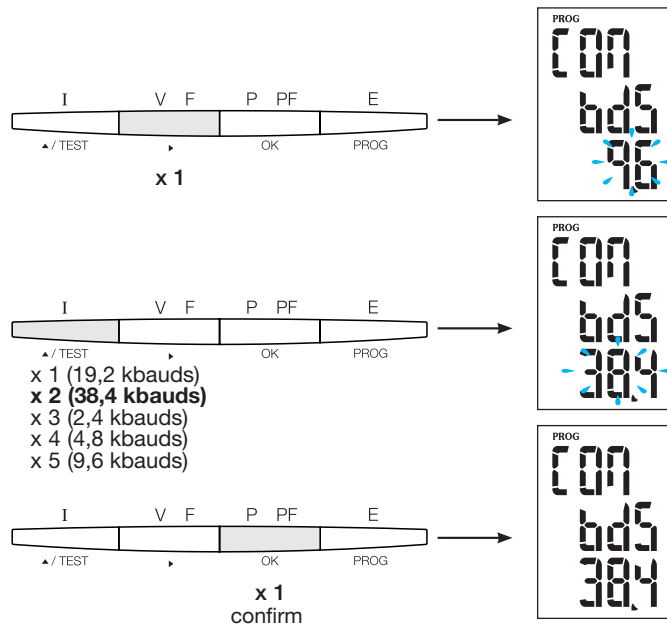

7.1.2.4.3 Setting the parity

Press button ▲ to access this configuration item.

Example: **PAR = EvEn**

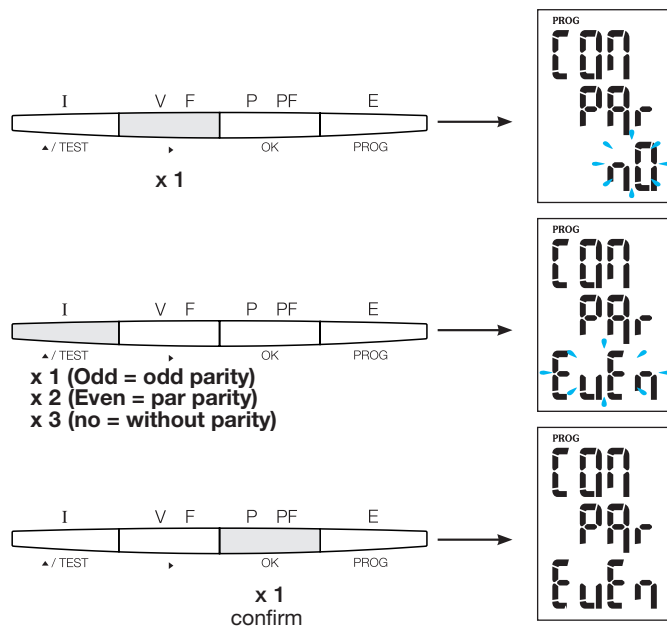

7.1.2.4.4 Setting the stop bit

Press button ▲ to access this configuration item.

Example: Stop = 2

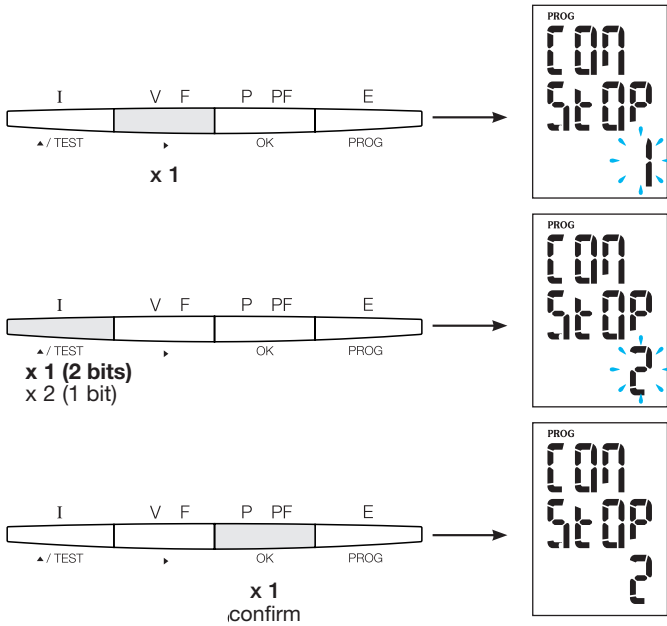

7.1.2.5 To quit and save programming

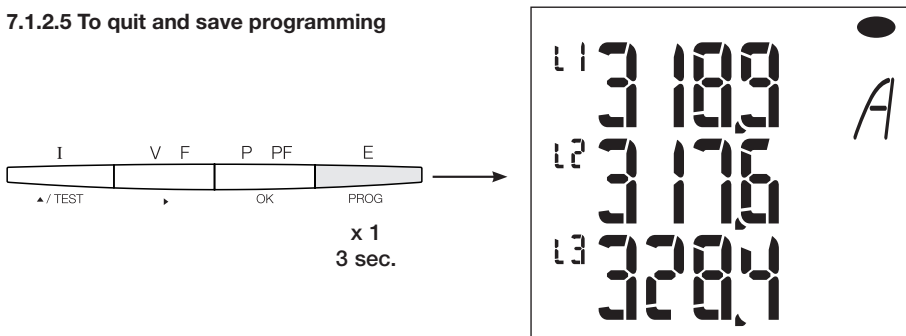

7.1.2.6 Function test for the electrical wiring connections

During testing, device SM102E must be supplied with current and voltage to all connections. Testing requires a power factor of the installation between 0.6 and 1. If the power factor of the installation falls outside this range, the test cannot be performed. In the case of 4 BL / 3 BL / 2 BL / 1 BL only the connection of the current transformer is tested. In the case of 4 NBL and 3 NBL the connection as a whole is controlled.

Error	Error description
Err0	There is no error
Err 1 / 2 / 3	Reversed polarity of current transformer on phase 1 / phase 2 / phase 3
Err4	Reversed polarity of voltage between V1 and V2
Err5	Reversed polarity of voltage between V2 and V3
Err6	Reversed polarity of voltage between V3 and V1

7.1.2.6.1 Example of test operation without error

Press and hold button "Test" for at least 3 seconds to start testing the connections. If, as shown in the example, no error is found, press and hold button "Test" again for at least 3 seconds to return to display mode.

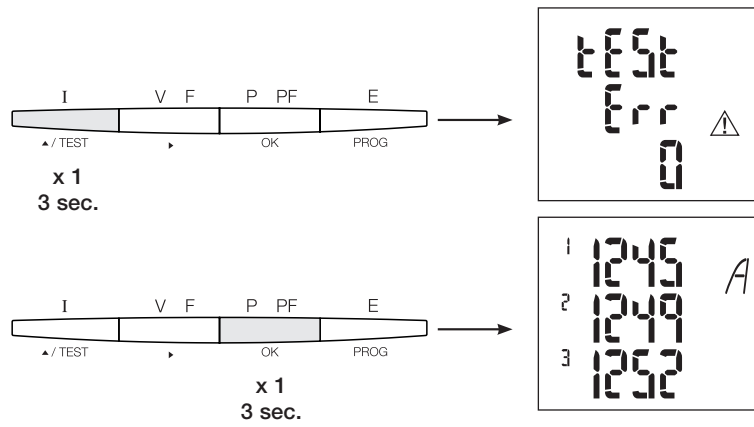

7.1.2.6.2 Test with error detection

Existing errors Err1 / 2 / 3 can be resolved automatically by selecting the corrective function. This eliminates the need for re-wiring.

Example: Err 1 - current transformer connection of phase 1

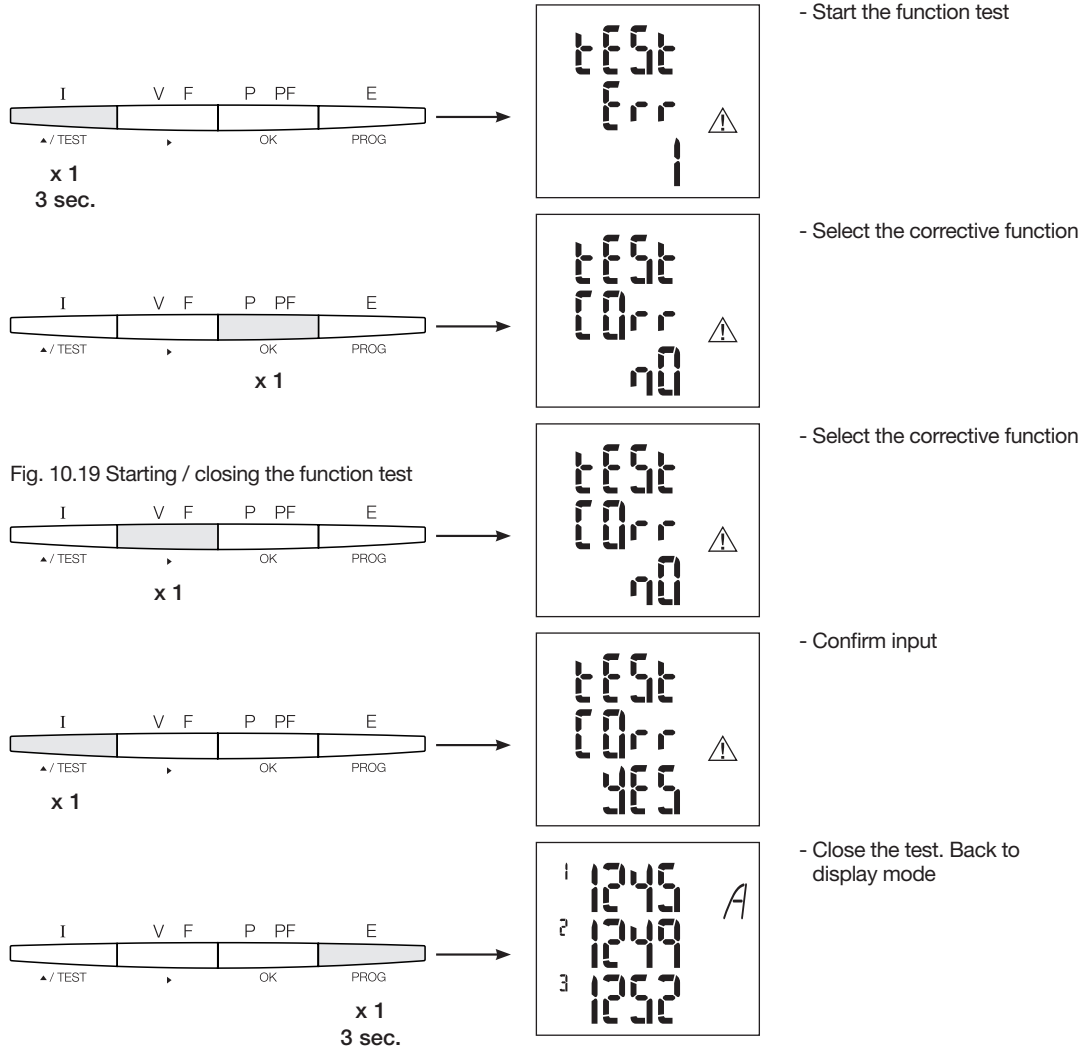

For the Err 4 / 5 / 6 the modification must be performed manually by correcting the voltage connections

7.1.3 Commissioning the SM103E

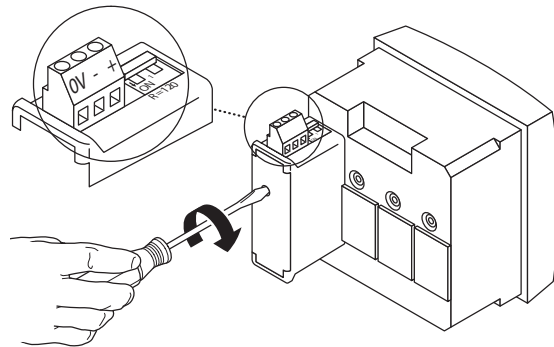
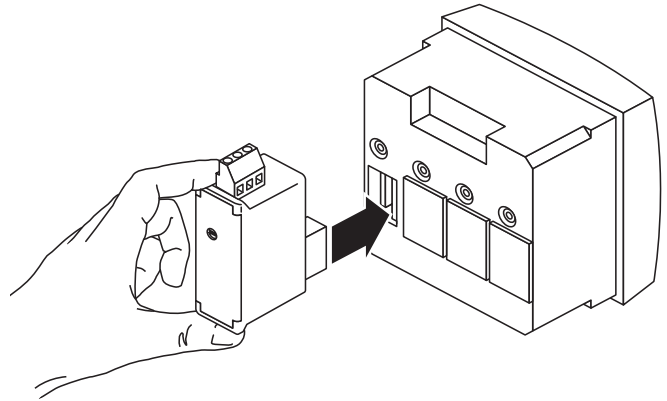
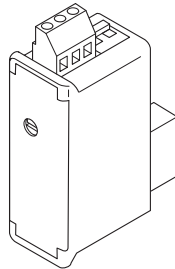
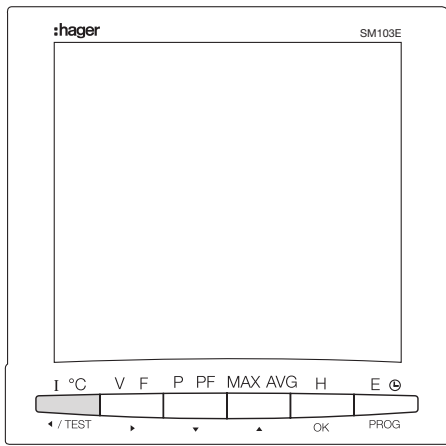

Warning

Before switching on the SM103E, the Modbus module SM211 is too fitted onto the back of the power meter in one of the four positions provided, and to be wired.

Make sure that the power supply and the different connections are properly connected. If you have a doubt, please consult the SM103E instruction manual.

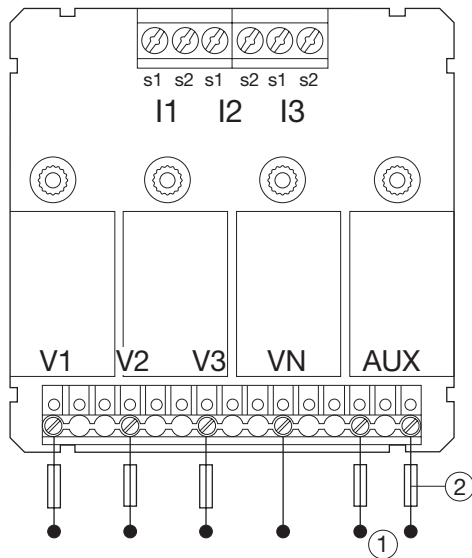

If the device is located at the beginning or termination of the Modbus line, the 2 dip-switches on the communication module must be set on the "ON" position for the resistance activation.

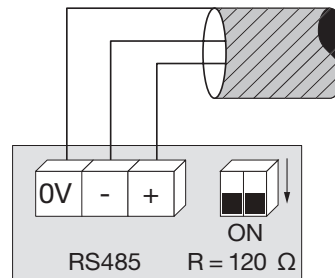

0V terminal is used for the cable shield connection and not common.

7.1.3.1 Access to programming mode: pass code 100

Press and hold button "PROG" for at least 3 seconds to access the configuration level.
"100" is configured as code by default.

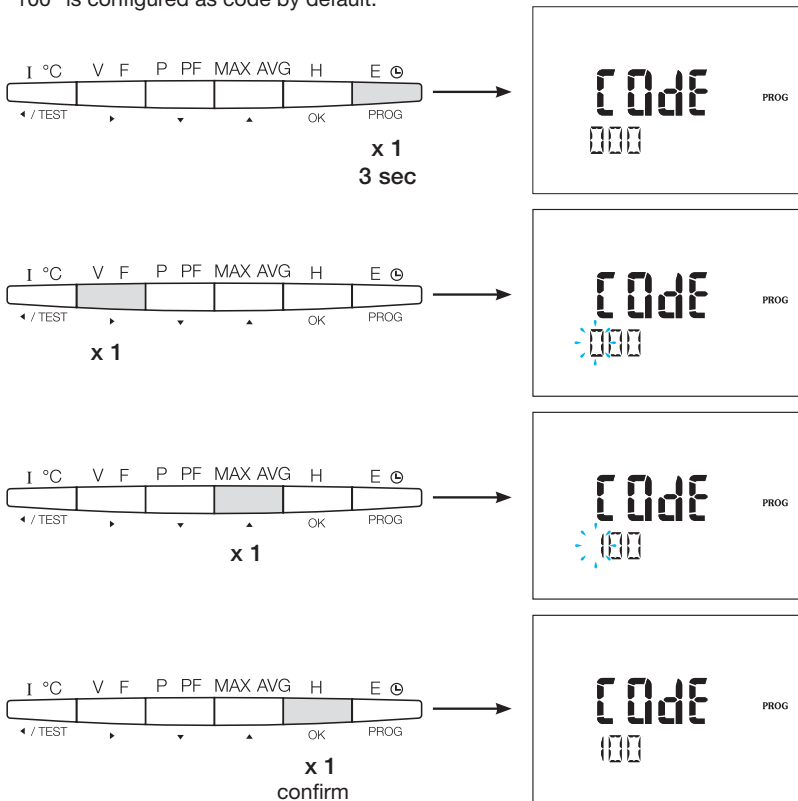

After opening programming mode, press button ▲▼ repeatedly to select the desired menu.

i Advice

Set or check at least these configurations: network type, current and voltage transformer as following. (For the complete programming, please refer to the SM103E instruction manual)

7.1.3.2 Network type

(first menu, when opening programming mode).
The example shows the setting for a three-phase network with asymmetric load.

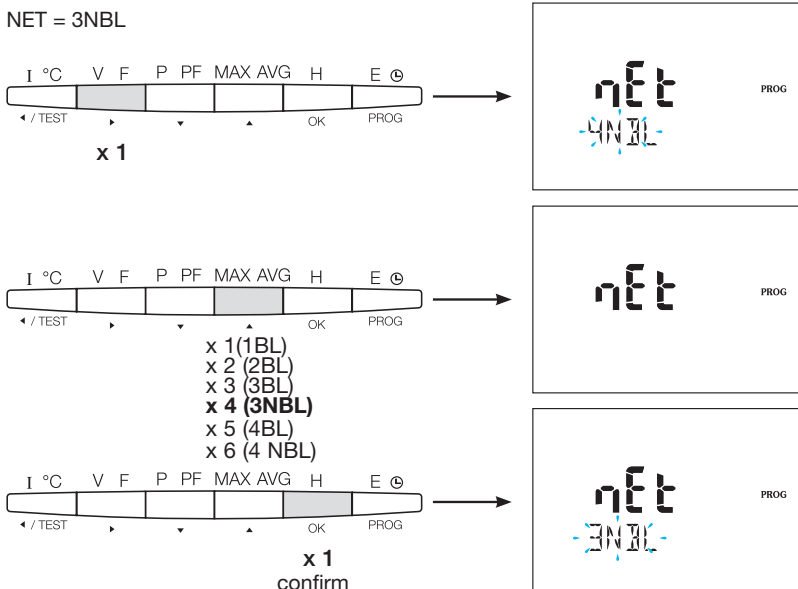

7.1.3.3 Current transformer CT

Press button ▲ to access this configuration item. The secondary side of multifunctional device SM103E can be set to 1 A or 5 A.

Example: Transformer ratio CT = 1500 / 5 A

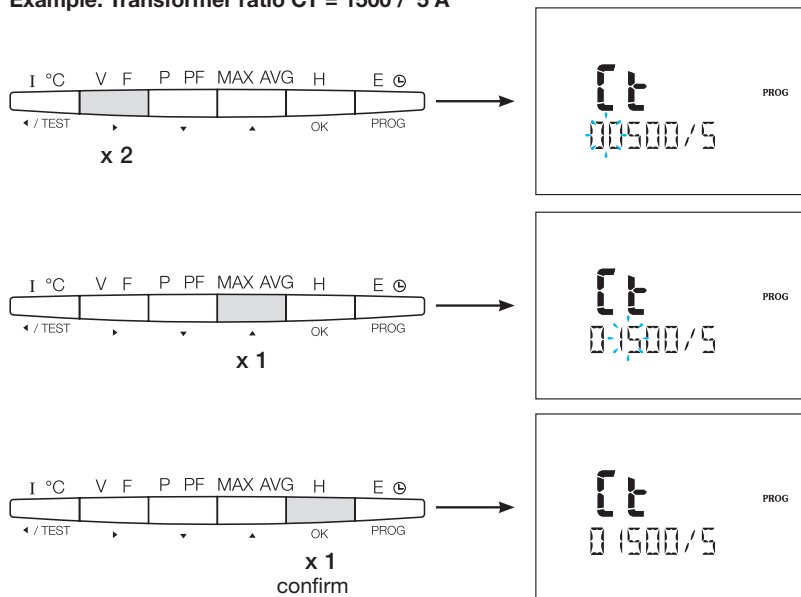

7.1.3.4 Voltage transformer UT (if used)

Press button ▲ to access this configuration item. The use of a voltage transformer must be enabled at this point.

Example: Connection via voltage transformer (YES/NO) Vt = YES

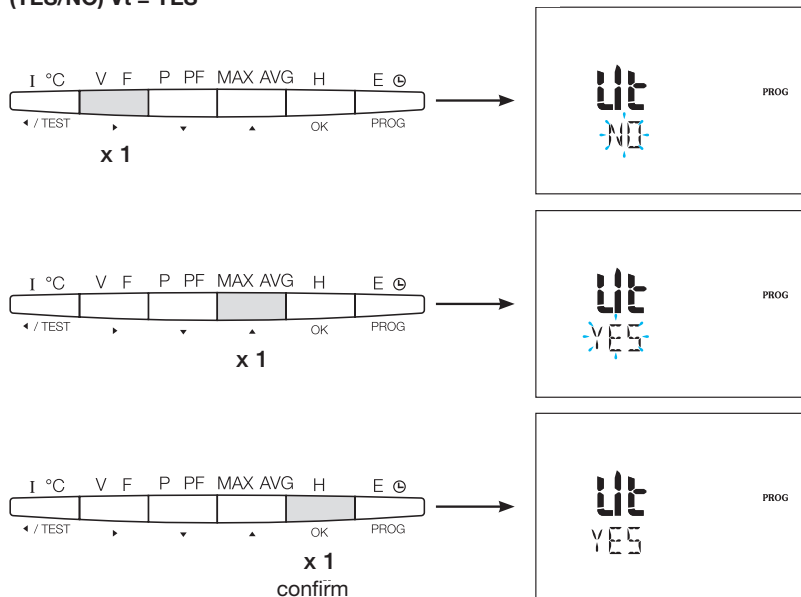

7.1.3.4.1 Voltage transformer primary side

Voltage transformer primary sides can be set up to 500,000 VAC.

Example: Primary voltage = 20000 V PR = 20000

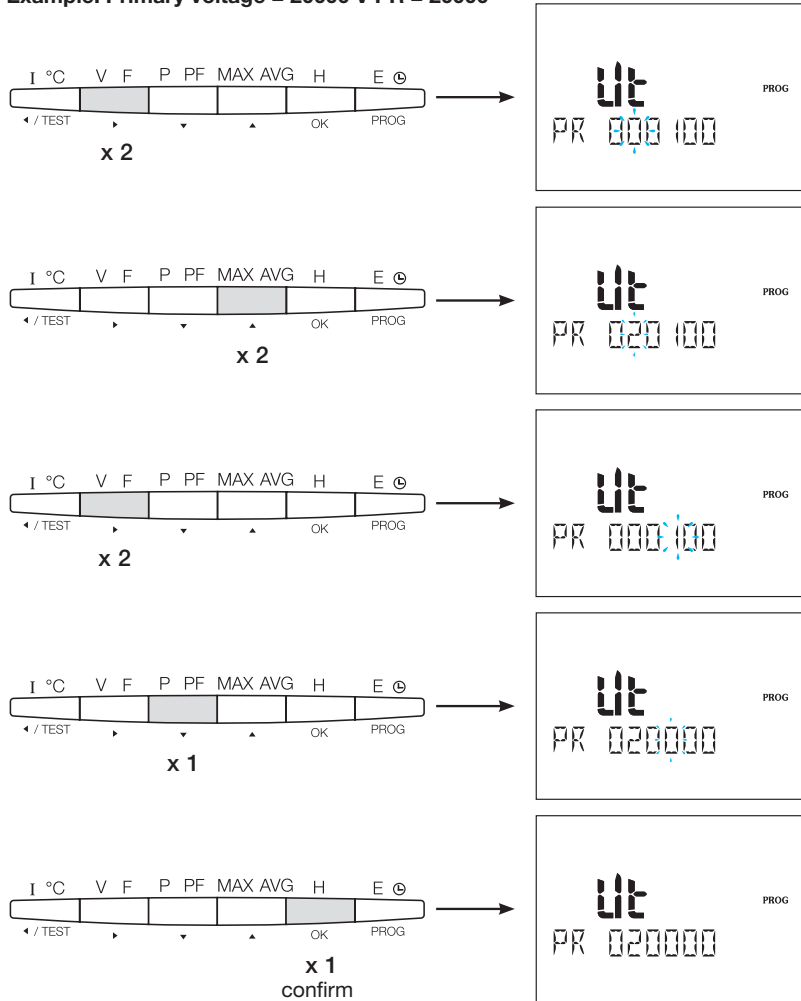

7.1.3.4.2 Voltage transformer secondary side

The values shown in the example can be assigned to the voltage transformer's secondary side.

Example: Secondary voltage = 110 V PR = 110

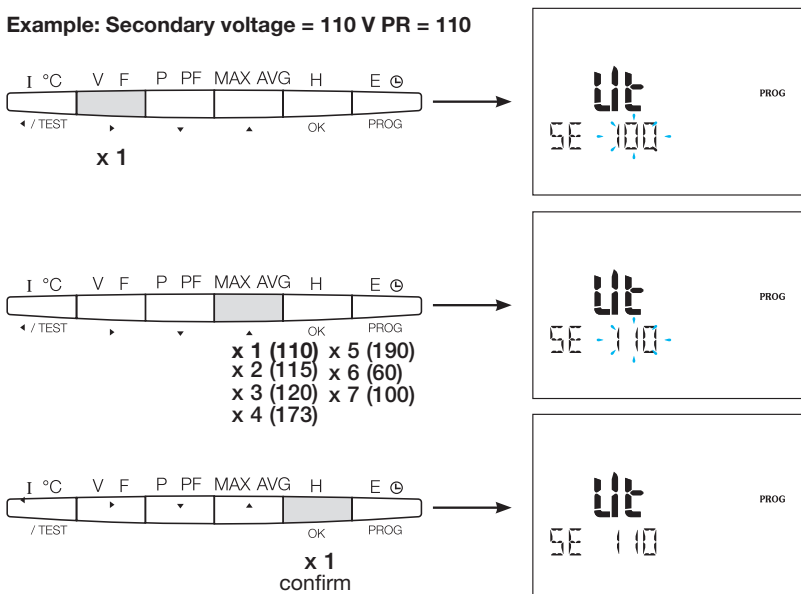

7.1.3.5 Modbus configuration

7.1.3.5.1 Communication address

Press button ▲ to access this configuration item.

Example: COm ADR = 007

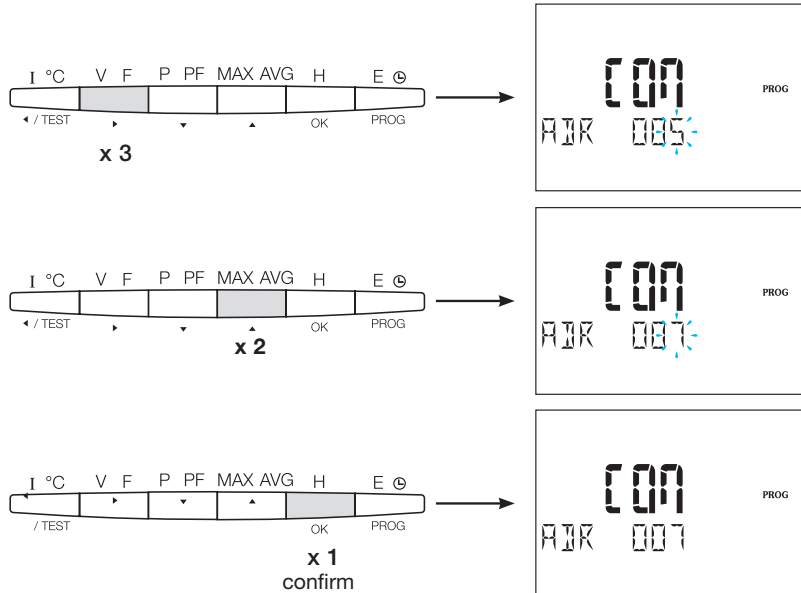

7.1.3.5.2 Setting the transfer rate

Press button ▲ to access this configuration item.

Example: BDS = 19200 bauds

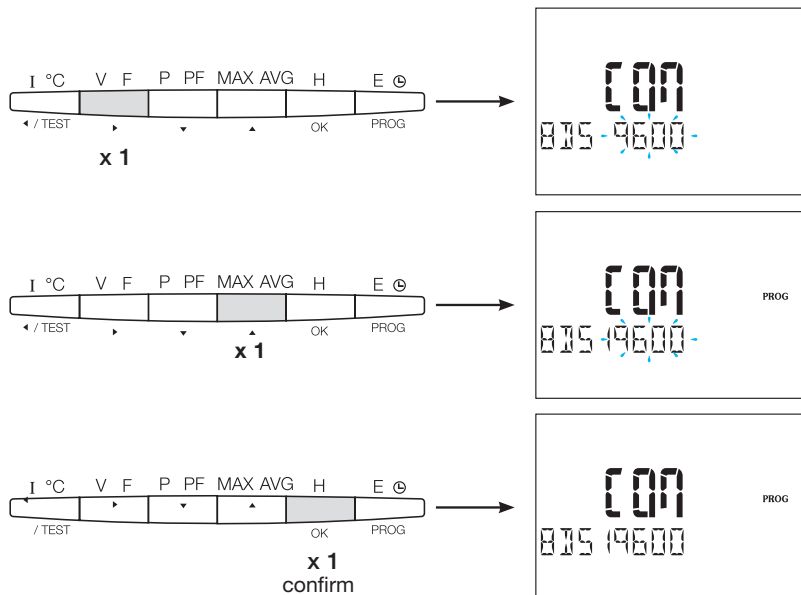

7.1.3.5.3 Setting the parity

Press button ▲ to access this configuration item.

Example: PAR = Even

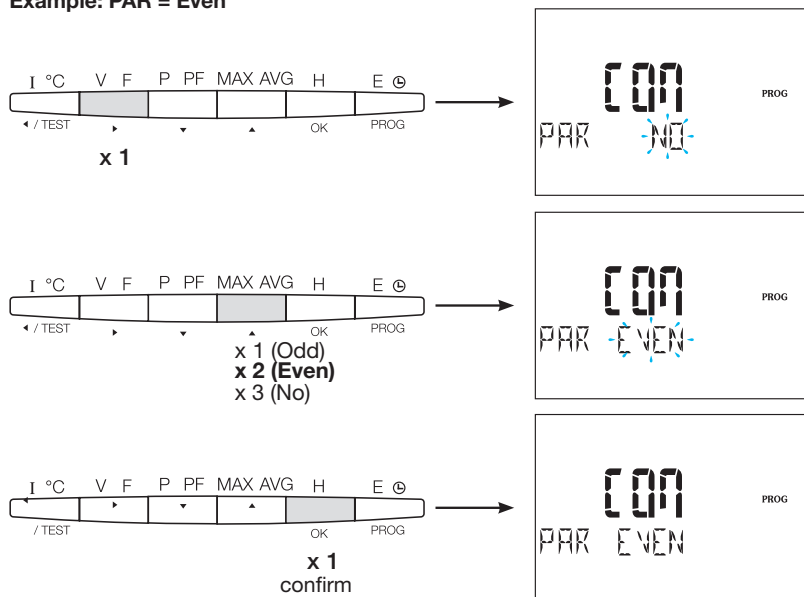

7.1.3.5.4 Setting the stop bit

Press button ▲ to access this configuration item.

Example: STOP = 2

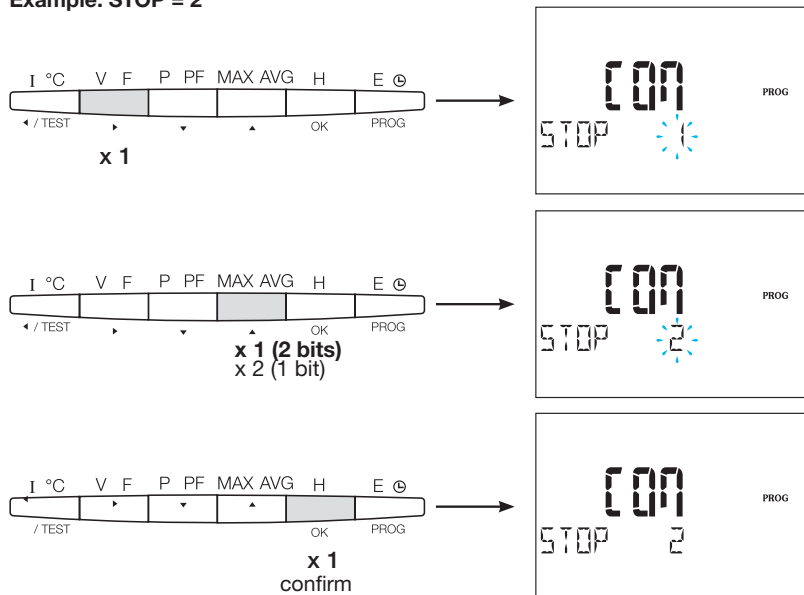

7.1.3.6 To quit and save programming

Press button "PROG" for 3 seconds to exit the configuration level.

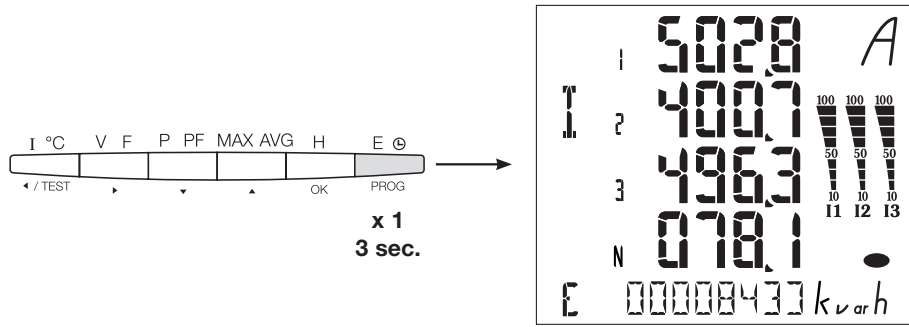

When the communication is established between the master and the slave, the activity indicator "COM" is blinking on the display.

7.1.3.7 Function test for the electrical wiring connections

During testing, device SM103E must be supplied with current and voltage to all connections. Testing requires a power factor of the installation between 0.6 and 1. If the power factor of the installation falls outside this range, the test cannot be performed. In the case of 4 BL / 3 BL / 2 BL / 1 BL only the connection of the current transformer is tested. In the case of 4 NBL and 3 NBL the connection as a whole is controlled.

Error	Error description
Err0	There is no error
Err 1 / 2 / 3	Reversed polarity of current transformer on phase 1 / phase 2 / phase 3
Err4	Reversed polarity of voltage between V1 and V2
Err5	Reversed polarity of voltage between V2 and V3
Err6	Reversed polarity of voltage between V3 and V1

7.1.3.7.1 Example of test operation without error

Press and hold button "Test" for at least 3 seconds to start testing the connections. If, as shown in the example, no error is found, press and hold button "Test" again for at least 3 seconds to return to display mode.

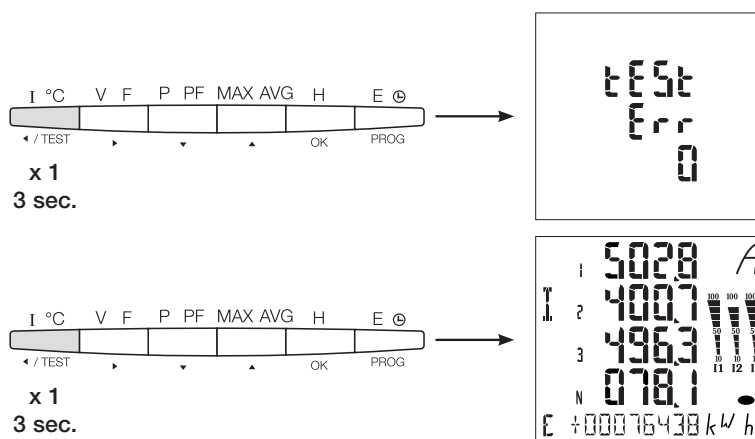

7.1.3.7.2 Test with error detection

Existing errors Err1 / 2 / 3 can be resolved automatically by selecting the corrective function, this eliminates the need for re-wiring.

Example: Err 2 - current transformer connection of phase 2

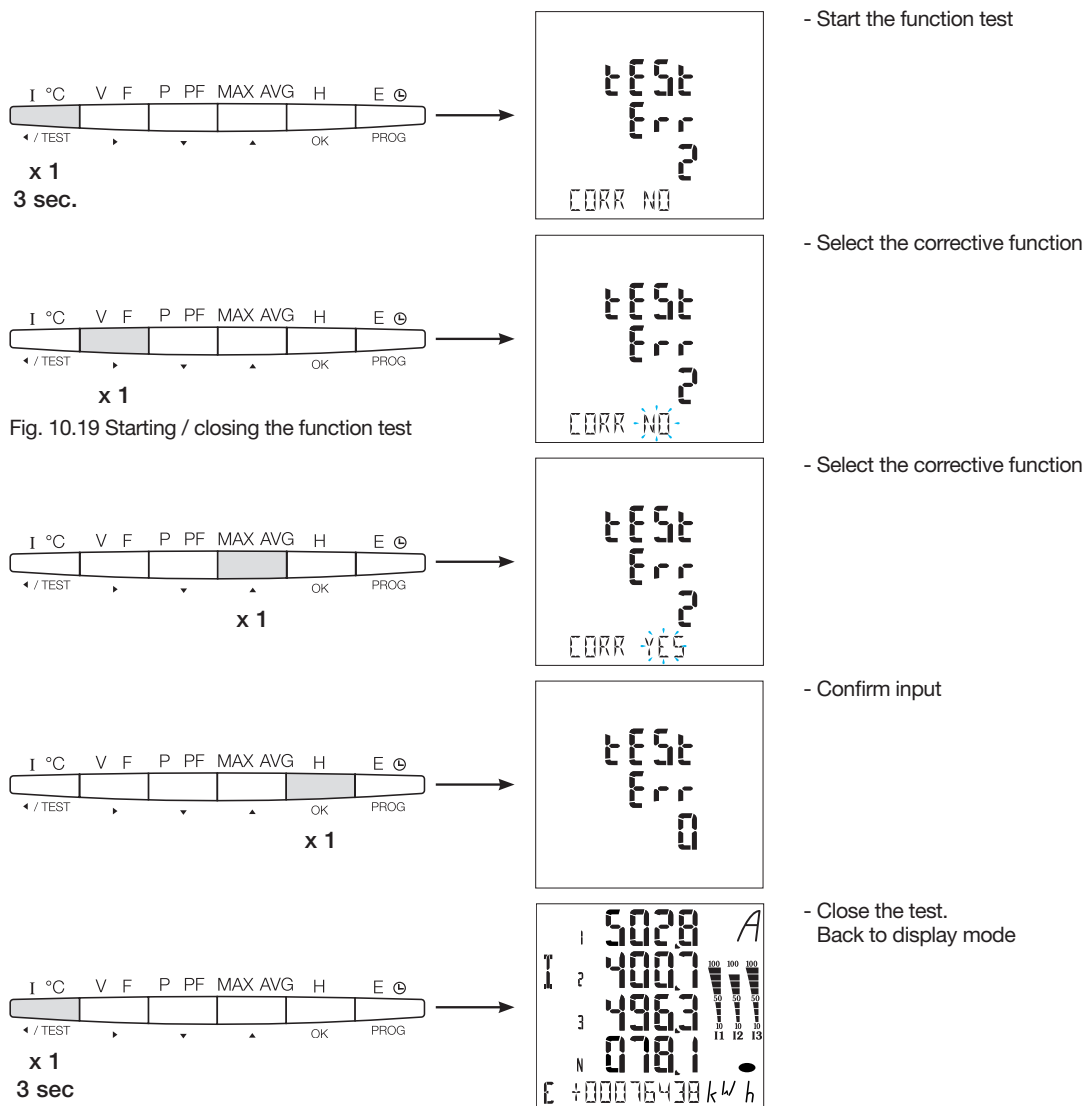

For the Err 4 / 5 / 6 the modification must be performed manually by correcting the voltage connections

7.2 Modbus sub-meters

7.2.1 Commissioning of the ECR140D meter



Check that the power supply and the different connections are correctly connected before putting the device into operation. If any doubt, please refer to the instruction manual of ECR140D.

Wiring diagram principle of ECR140D

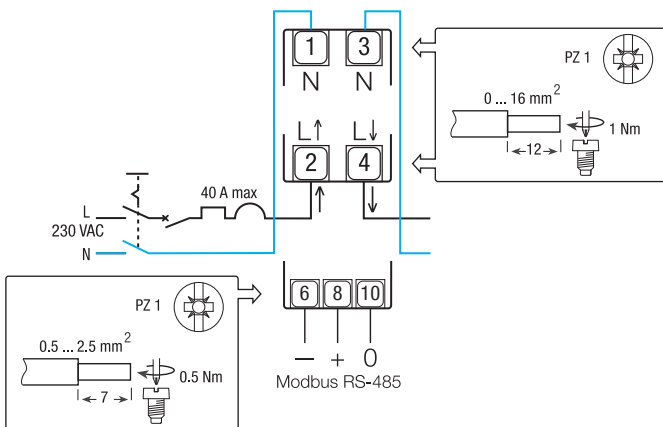

Structure of the Programming menu

7.2.1.1 Access to the programming mode Main menu in case of Modbus

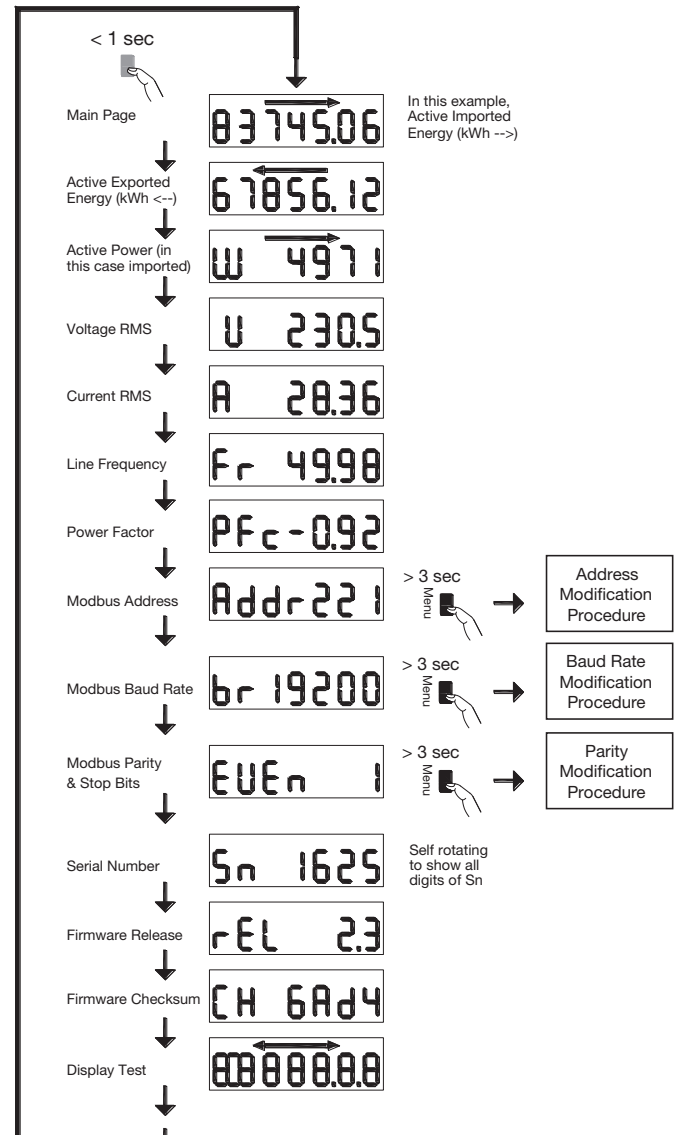

Commands

- Command button:**
 - Short press:** Push briefly (<1 sec.) the button and then release it. Used to scroll pages or during parameter's modification.
 - Long Press:** Keep the button pushed for at least 3 seconds. Used to start and to confirm parameter's modifications.

5000 imp/kWh
Optical metrological LED

Note: If no button is pushed for at least 20 seconds the display goes back to the Main Page.

7.2.1.2 Adress modification procedure

The Modbus address can be selected between 1 and 247, the M-Bus Primary Address between 1 and 250. In the following example, its value is modified from 49 to 131.

• First digit

In the Address Page of the Main Menu, push the button for more than 3 seconds. The first digit starts blinking, meaning that it is under modification. Push shortly the button twice to change the digit value from 9 to 1. Then, push again the button for at least 3 sec. to confirm the digit value. The second digit will start blinking.

• Second digit

Push shortly the button 9 times to modify the value of the second digit from 4 to 3. Then, push again the button for at least 3 sec to confirm the digit value. The third digit will start blinking.

• Third digit

Push shortly the button to modify the value of the third digit from 0 to 1. Then, push again the button for at least 3 sec to confirm the new value of the Modbus Address. The digits stop blinking, and the Page scrolling is re-enabled.

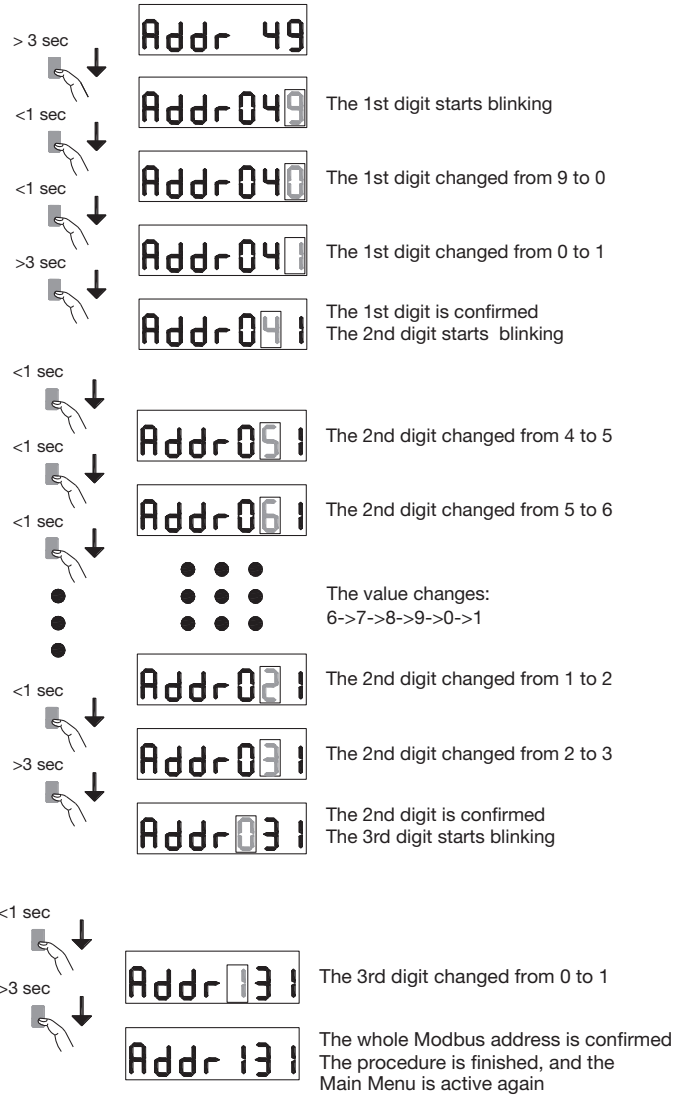

7.2.1.3 Baud rate modification procedure

In case of Modbus, it is possible to select one of the following Baud Rates: 1200, 2400, 4800, 9600, 19200 and 38400. In case of M-Bus the available Baud Rates are: 300, 600, 1200, 2400, 4800 and 9600.

In the Baud Rate Page, push the button for more than 3 seconds. The value starts blinking. Push shortly twice the button to change the value from 38400 to 2400. Then, push again the button for at least 3 seconds to confirm the value. The display stops blinking and the Page scrolling is re-enabled.

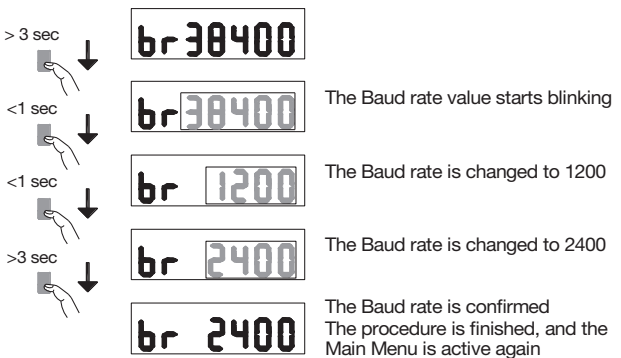

7.2.1.4 Parity & stops bits modification procedure (Modbus only)

The available combinations of values are:

Parity	Stop Bits	
None	1	
None	2	Modbus compliant (*)
Odd	1	Modbus compliant (*)
Odd	2	
Even	1	Modbus compliant (*)
Even	2	

(*) According to Modbus recommendation, Modbus RTU requires always 10 bits:
 8 bits per byte + 2 Stop bits in case of No parity
 8 bits per byte + 1 Parity bit + 1 Stop bits in case parity Odd or Even
 The other combinations work properly but are not compliant to Modbus recommendation.

The combinations are selectable in the sequence:
 ... -> None 1 -> None 2 -> Odd 1 -> Odd 2 -> Even 1 -> Even 2 -> back to None 1

For example, suppose you want to modify the combination of values from Parity = None and Stop Bits = 2 to Parity = Even and Stop Bits = 1. In the Parity/Stop Bits page of the Main menu, push the button for more than 3 seconds. The value starts blinking. Push shortly the button 3 times to change the value from None,2 to Even,1. Then, push again the button for at least 3 sec to confirm the value. The display stops blinking and the Page scrolling is re-enabled.

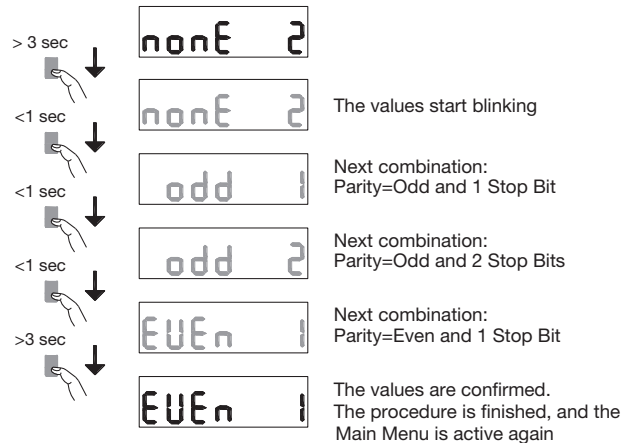

Modbus RTU Communication

Recommendations:

Use HTG485H reference cable specially developed as accessory by Hager.

Important:

It is essential to connect a resistance (reference SMC120R) of 120 Ohms at the 2 ends of the connection.

Modbus protocol:

The Modbus protocol operates on a master/slave structure:

- Reading (Function 3),
 - Writing (Function 6 or 16), broadcast option at address 0.
- The communication method is RTU (Remote Terminal Unit) with hexadecimal.

7.2.2 Commissioning of the ECR180X, ECR3XXX / ECA180X, ECA3XXX meters

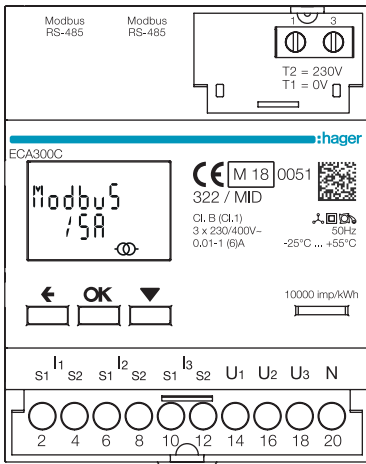

Commands

- OK** **OK** button: is used to confirm a modification of a parameter (or of a digit of a numerical parameter) or to answer to a question.
- SCROLL** **SCROLL** button: is used to scroll Menu pages or to modify the whole value or a digit of a parameter
- ESCAPE** **ESCAPE** button: is used to escape to main menu from anywhere or to skip back to the previous digit of the value under modification
- 10000 imp/kWh** Optical metrological LED

Note:
If no button is pushed for at least 20 seconds the display goes back to the Main Page and the backlight is switched off again.

Check that the power supply and the different connections are correctly connected before putting the device into operation.
If any doubt, please refer to the instruction manual of ECR180X, ECR3XXX / ECA180X, ECA3XXX.

• Wiring diagram principle of ECR180X, ECR3XXX (connection with terminals)

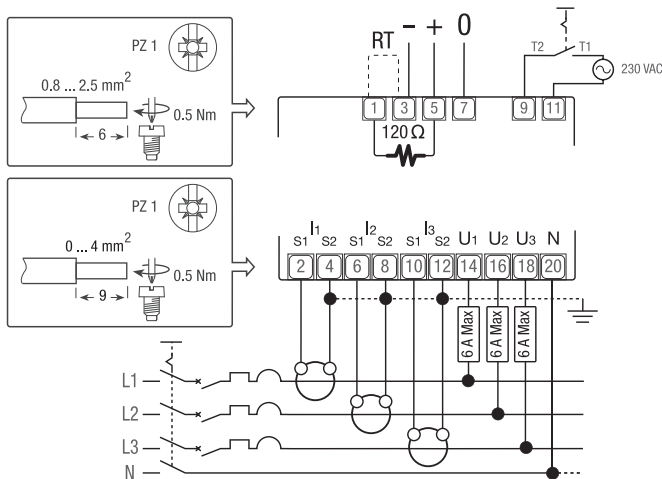

• Wiring diagram principle of ECA180X, ECA3XXX (RJ45 connection)

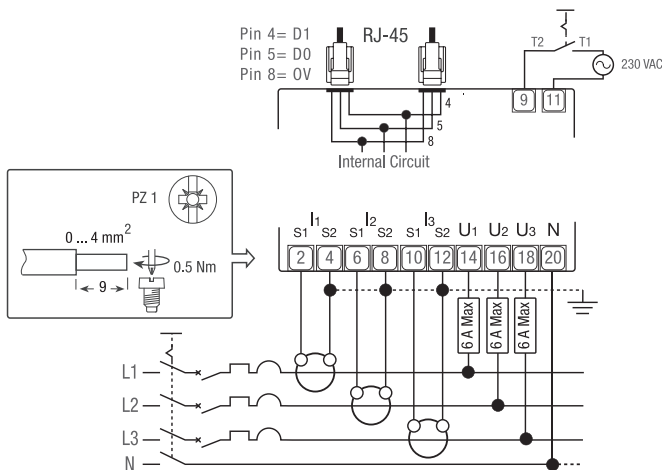

Structure of the Programming menu

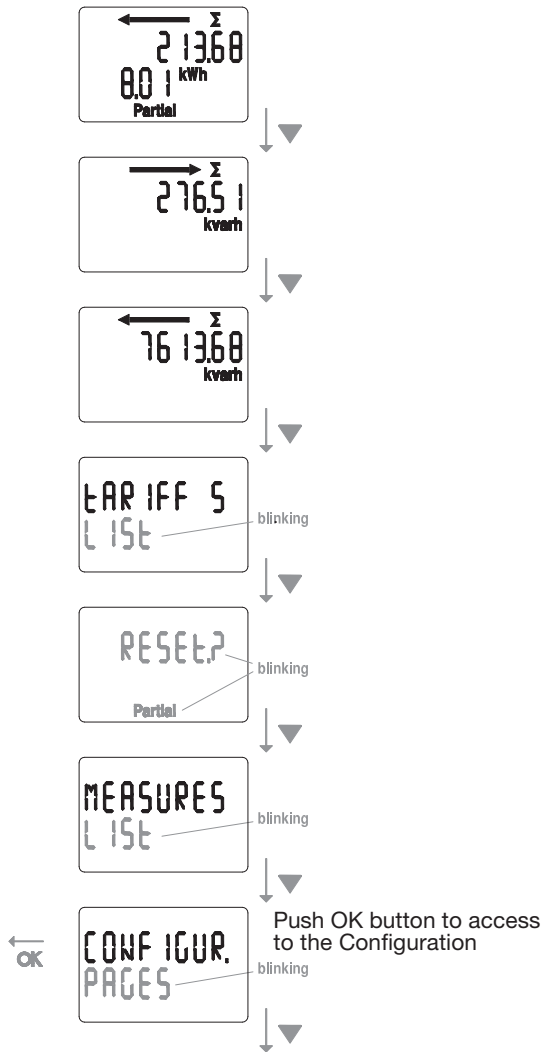

7.2.2.1 Access to the programming mode



7.2.2.2 Address modification procedure



7.2.2.3 Baud Rate modification procedure



7.2.2.4 Parity modification procedure



7.2.2.5 Stops bits modification procedure



To the first menu parameter page

Modbus RTU Communication

Recommendations:

Use HTGxxxH reference cables specially developed as accessories by Hager.

Important:

It is essential to connect a resistance (reference HTG467H) of 120 Ohms at the 2 ends of the connection.

agardio system:

The plug-in and services for ECA300C are directly integrated in agardio manager HTG41xH.

Error condition:

When partial energy blinks, reset partial energy (maximum partial energy register). When the display shows the message ERROR N02 or ERROR N03, the meter has got a malfunction and must be replaced.

7.2.3 Commissioning the EC366 / EC367M

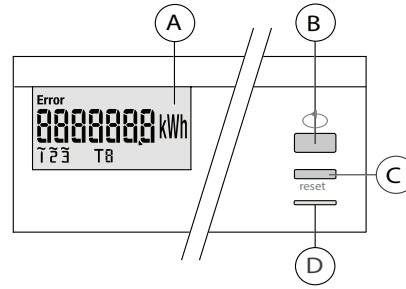
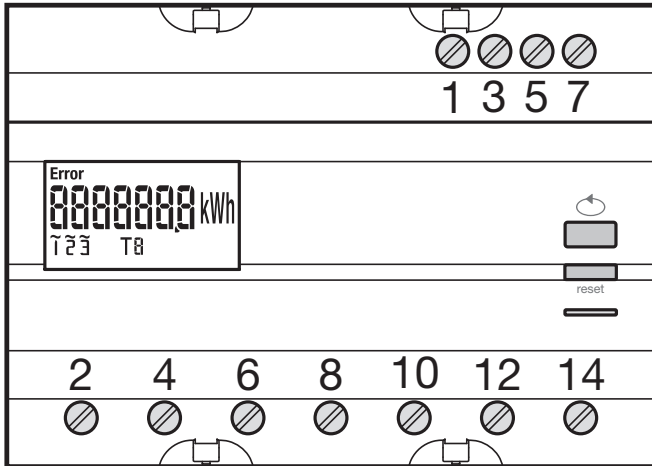

- Ⓐ LCD display
- Ⓑ Button for value scrolling
- Ⓒ Program access menu / Reset button to reset partial meter (function not available for the EC 367M, MID)
- Ⓓ Metrological LED (2 Wh/impulse).

Make sure that the different connections are properly connected as below, before you switch on the device.

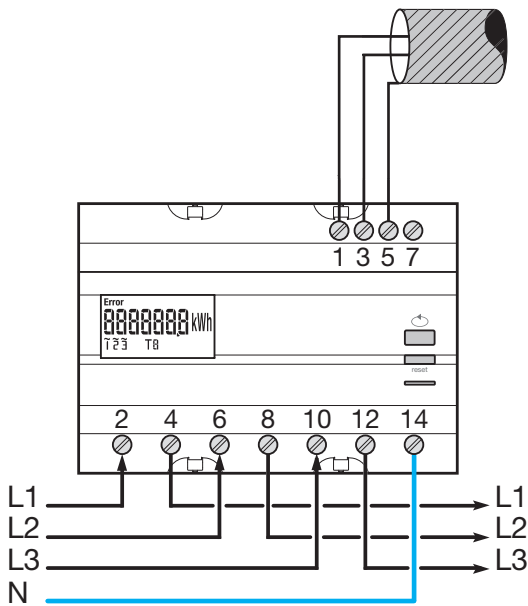

Programming menu structure

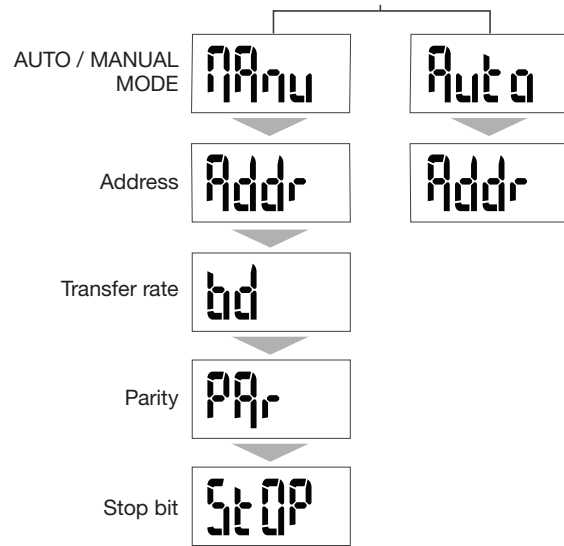

For the commissioning we suggest to use the manual mode function.

If the meter device is integrated into the RS485 daisy chain network as first or terminal device, the resistor 120 Ω provided must be connected between the terminals 1 - 3 "+" and "-".

7.2.3.1 Access to programming mode

Press button C "Prog" shortly to access configuration mode



(Press button B for the selection Auto mode, not recommended at the commissioning), Otherwise press again the button C "Prog"

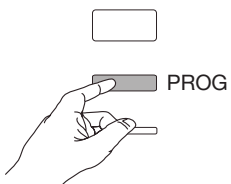

7.2.3.2 Communication address

Scroll with button B to select the address

Example: addr = 012



Validate and continue with button C "Prog"

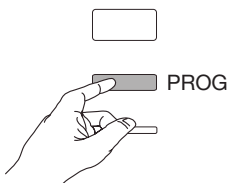

7.2.3.3 Setting the transfer rate

Scroll with button B to select the transfer rate

Example: bd = 19200

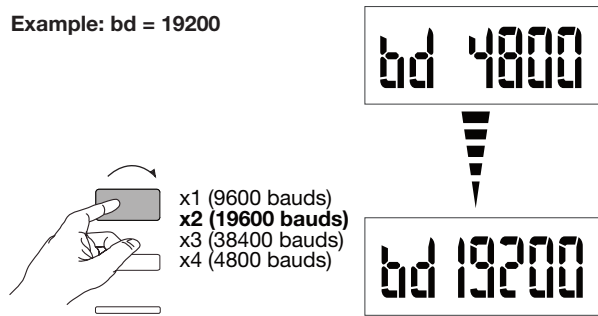

Validate and continue with button C "Prog"

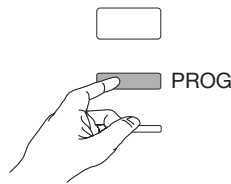

7.2.3.4 Setting the communication parity

Scroll with button B to select the parity

Example: Par = odd

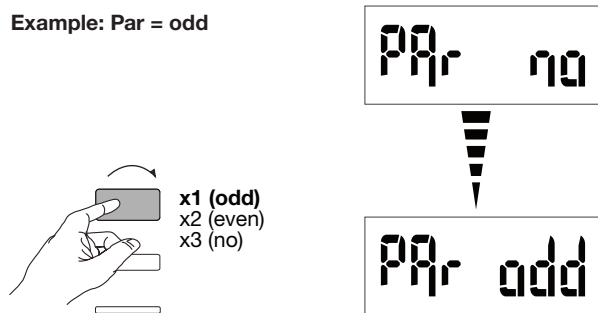

Validate and continue with button C "Prog"

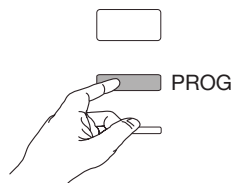

7.2.3.5 Setting communication stop bit

Scroll with button B to select stop 1 or 2

Example: Stop = 2

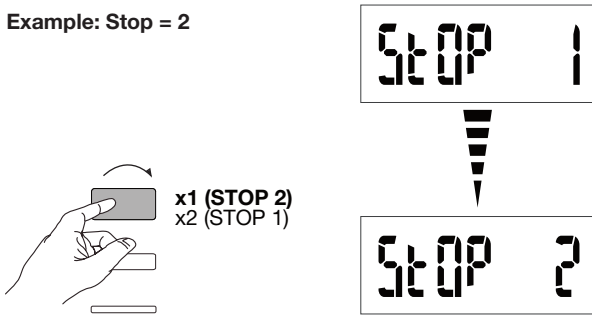

7.2.3.6 Quit and save programming

Press button C "Prog" for at least 5 seconds

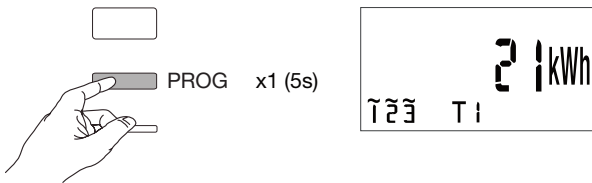

 **Warning**

The programming level is exited automatically after two minutes if no input is made. Changes will not be saved!

7.2.3.7 Function test for the electrical wiring connections

The energy meter must be connected to the voltage supply and a load must be connected.

This function can only be used if the power factor of the installation is between 0.6 and 1 and minimum current consumed on each phase = 20 A

Press and hold button B for at least 3 seconds.

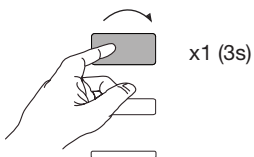

The messages below indicate you the connection status of phases in the meter device.

Error	Error description
Err 0	no error
Err 1	reversed phase connection 1 (L1 <=> L1')
Err 2	reversed phase connection 2 (L2 <=> L2')
Err 3	reversed phase connection 3 (L3 <=> L3')
Err 7	reversed connection of voltage between V1 and neutral conductor
Err 8	reversed connection of voltage between V2 and neutral conductor
Err 9	reversed connection of voltage between V3 and neutral conductor

Press button B for at least 3 seconds to exit this mode.

7.2.4 Commissioning the EC376

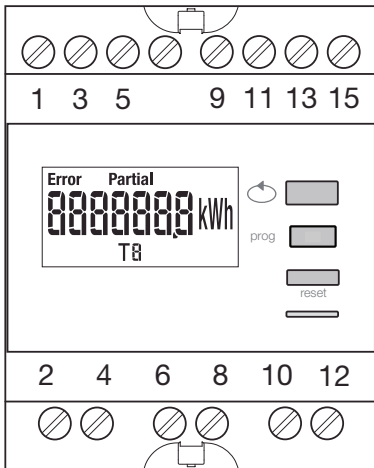

Make sure that the different connections are properly connected as below, before you switch on the device. (For the complete programming, please refer to the EC376 user instructions)

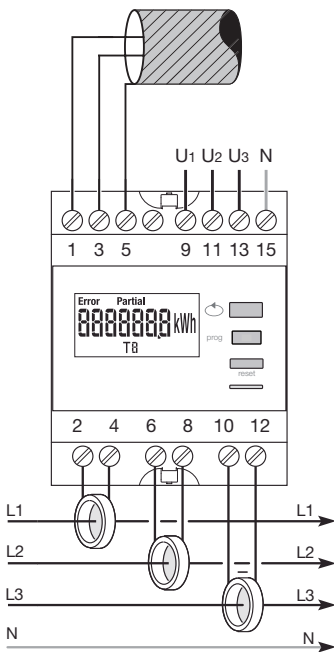

If the meter device is integrated into the RS485 daisy chain network as first or terminal device, the resistor 120 Ω provided must be connected between the terminals 1 - 3 "+" and "-".

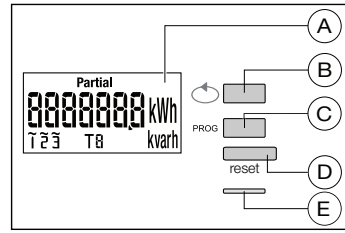

- Ⓐ LCD
- Ⓑ Button for value scrolling
- Ⓒ Button for access to programm menu
- Ⓓ Button for resetting the daily meter
- Ⓔ Metering LED (0.1 Wh/pulse)

Programming menu structure

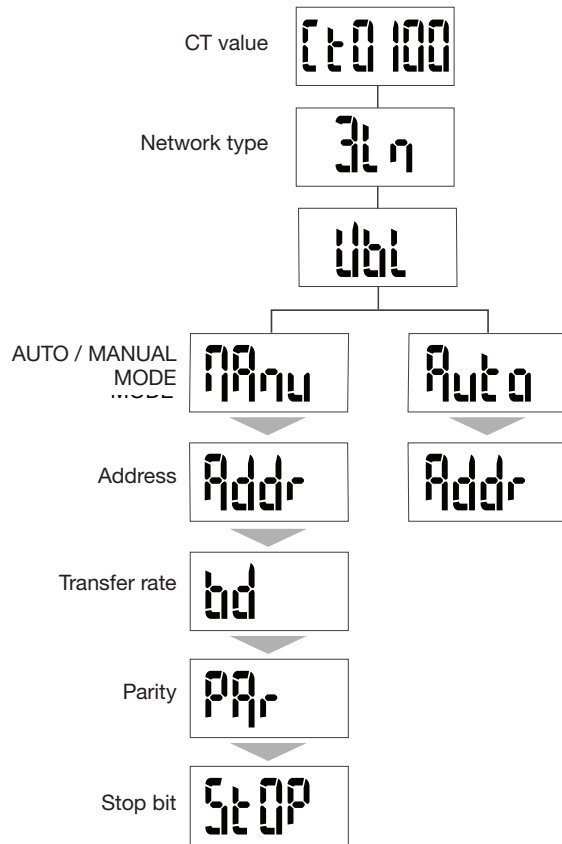

For the commissioning we suggest to use the manual mode function.



Advice

Set or check at least these configurations: current transformer, network type, as following.

7.2.4.1 Access to programming mode

Press button C "prog" for at least 5 seconds to access configuration mode.

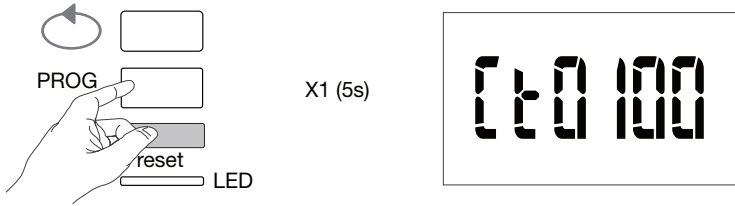

In configuration mode, press button C "prog" to open the subsequent menu.

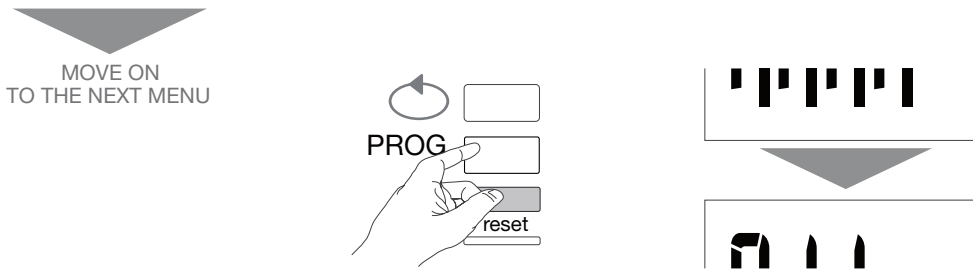

7.2.4.2 Setting the current transformer

Scroll with button B to select the primary current transformer value (50/6000A)

Example: CT = 800

CT value

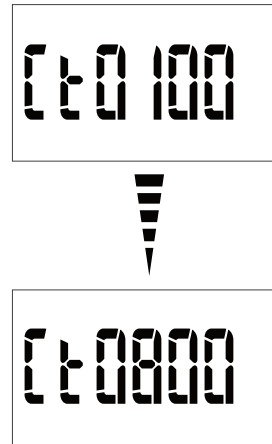
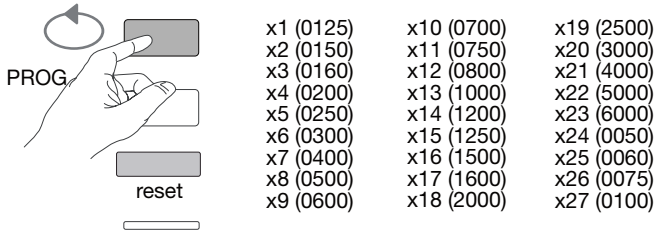

Validate and continue with button C "Prog"

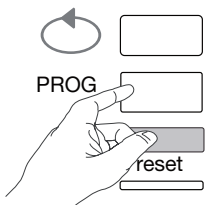

7.2.4.3 Setting the network type

The power network type (1L+N, 2L, 3L, 3L+N) is displayed.
Press button B repeatedly to scroll the different values and select the network type.

Example: 3L

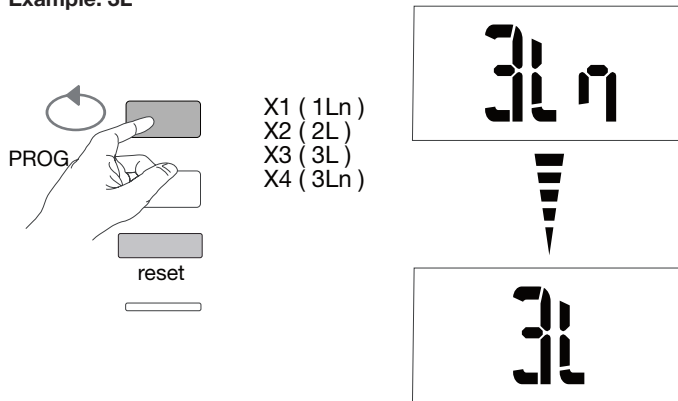

Validate and continue with button C "Prog"

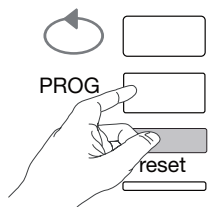

7.2.4.4 Setting the network consumer (3 phases or 3ph + N)

On three-phase installations, the consumer is displayed as "Balanced or Unbalanced" symmetric or asymmetric (Bl, Unbl).
Press button B repeatedly to scroll the values and select one of them.

Example: bL

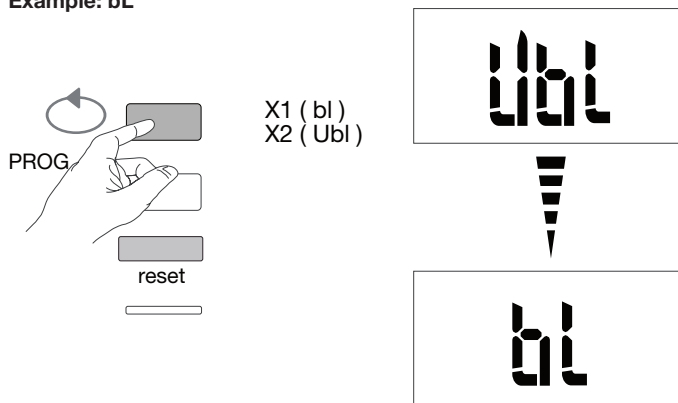

Validate and continue with button C "Prog"

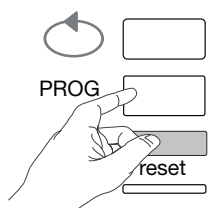

7.2.4.5 Selecting manual / automatic mode

Press button B repeatedly to scroll and select the manual mode

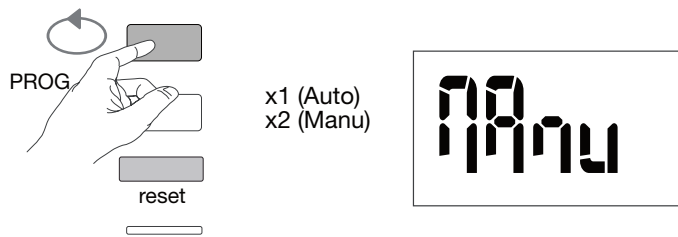

Validate and continue with button C "Prog"

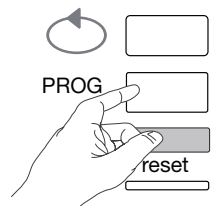

7.2.4.6 Communication address

Scroll with button B to select the address

Example: Addr = 12

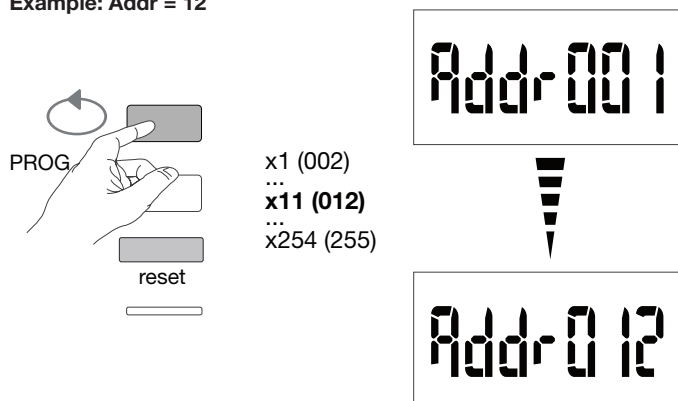

Validate and continue with button C "Prog"

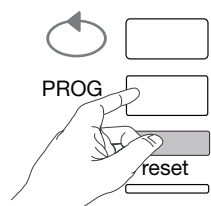

7.2.4.7 Setting the transfer rate

Scroll with button B to select the transfer rate

Example: bd = 19200

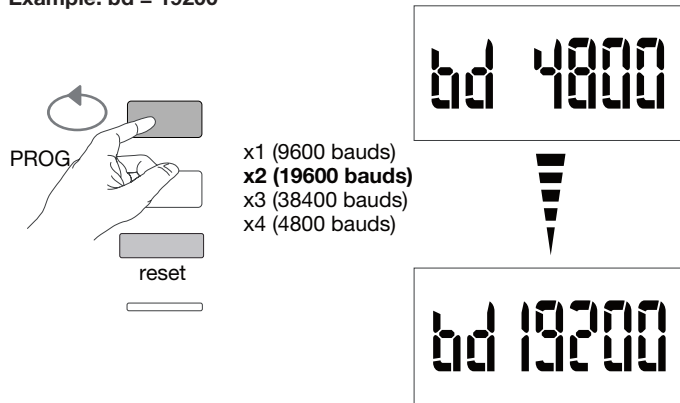

Validate and continue with button C "Prog"

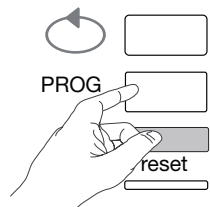

7.2.4.8 Setting the communication parity

Scroll with button B to select the parity

Example: Par = odd

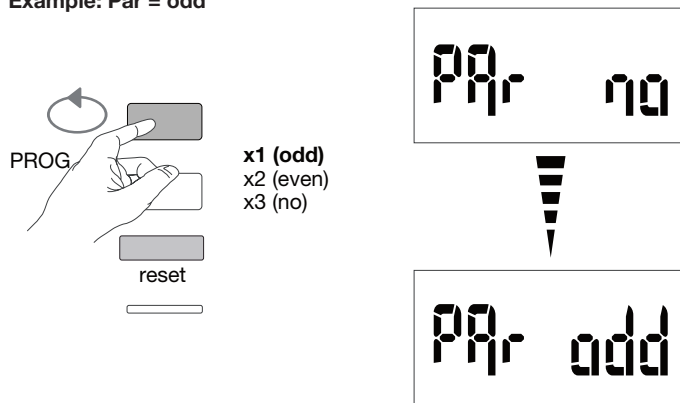

Validate and continue with button C "Prog"

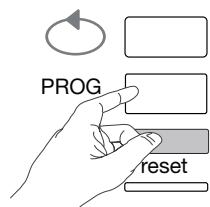

7.2.4.9 Setting communication stop bit
Scroll with button B to select stop bit 1 or 2

Example: StOP = 2

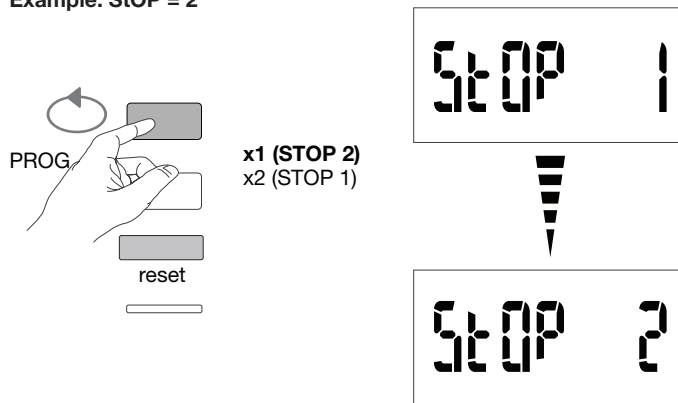

7.2.4.10 Quit and save programming

Press button C "Prog" for at least 5 seconds

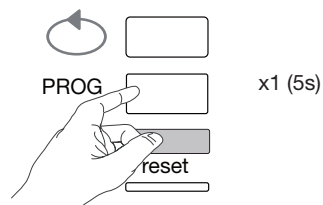

Warning

The programming level is exited automatically after two minutes if no input is made. Changes will not be saved!

7.2.4.11 Function test for the electrical wiring connections

The energy meter must be connected to the voltage supply and a load must be connected. This function can only be used if the power factor of the installation is between 0.6 and 1 and minimum current consumed on each phase = 20 % I_n .

Press and hold button B for at least 3 seconds.

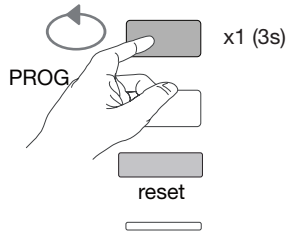

The messages below indicate you the connection status of phases in the meter device.

Error	Error description
Err 0	no error
Err 1 / 2 / 3	Reverse polarity of current transformer on phase 1/phase2/phase3
Err 4	Reversed polarity of voltage between V1 and V2
Err 5	Reversed polarity of voltage between V2 and V3
Err 6	Reversed polarity of voltage between V3 and V1
Err 7	reversed connection of voltage between V1 and neutral conductor
Err 8	reversed connection of voltage between V2 and neutral conductor
Err 9	reversed connection of voltage between V3 and neutral conductor

Press button B for at least 3 seconds to exit this mode.

7.2.5 Commissioning the EC377M

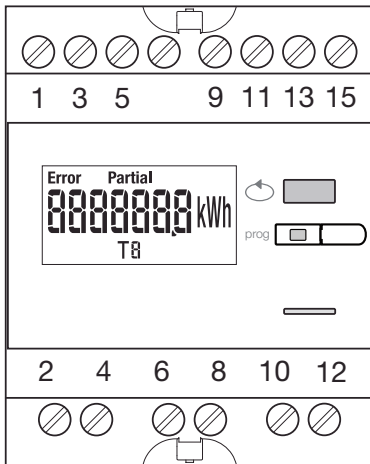

Make sure that the different connections are properly connected as below, before you switch on the device. (For the complete programming, please refer to the EC377M user instructions)

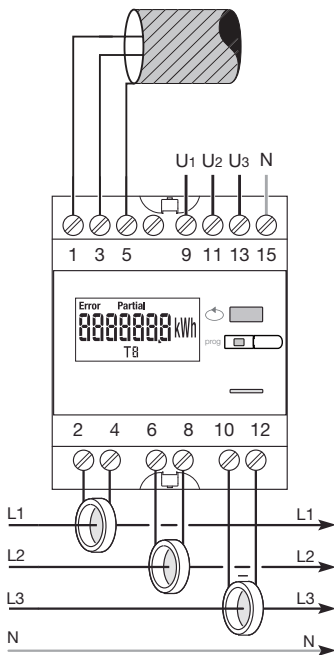

If the meter device is integrated into the RS485 daisy chain network as first or terminal device, the resistor 120 Ω provided must be connected between the terminals 1 - 3 "+" and "-".

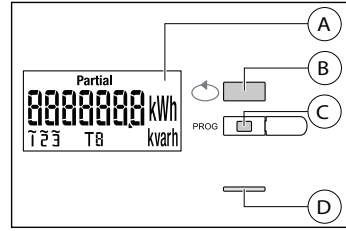

- Ⓐ LCD
- Ⓑ Button for value scrolling
- Ⓒ Button for access to programm menu
- Ⓓ Metering LED (0.1 Wh/pulse)

Programming menu structure

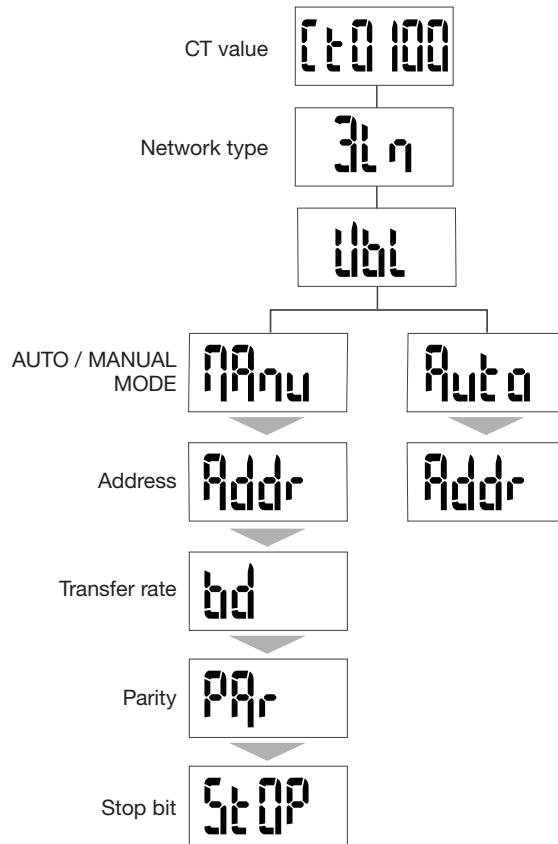

For the commissioning we suggest to use the manual mode function.



Advice

Set or check at least these configurations:
current transformer, network type, as following.

7.2.5.1 Access to programming mode

Press button C "prog" for at least 5 seconds to access configuration mode.

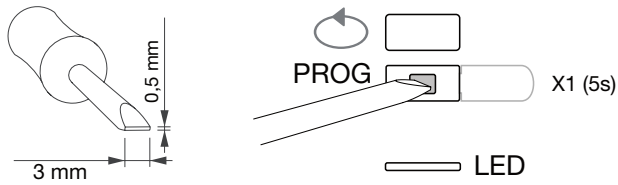

In configuration mode, press button C "prog" to open the subsequent menu.

7.2.5.2 Setting the current transformer

Scroll with button B to select the primary current transformer value (50/3000A)

Example: CT = 800

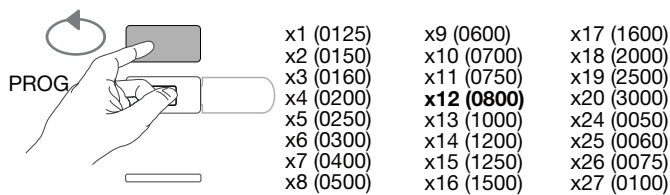

Validate and continue with button C "Prog"

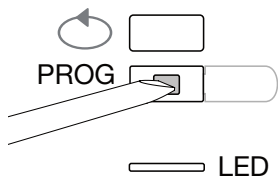

7.2.5.3 Setting the network type

The power network type (1L+N, 2L, 3L, 3L+N) is displayed. Press button B repeatedly to scroll the different values and select the network type.

Example: 3L

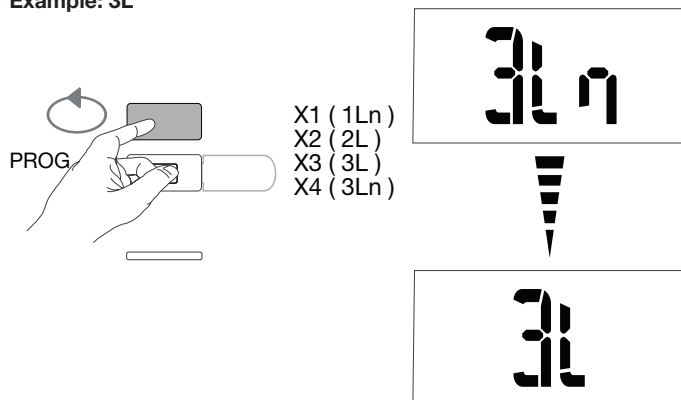

Validate and continue with button C "Prog"

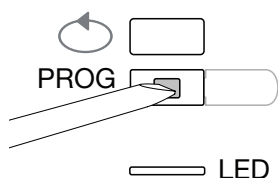

7.2.5.4 Setting the network consumer (3 phases or 3ph + N)

On three-phase installations, the consumer is displayed as "Balanced or Unbalanced" symmetric or asymmetric (Bl, Unbl). Press button B repeatedly to scroll the values and select one of them.

Example: bl

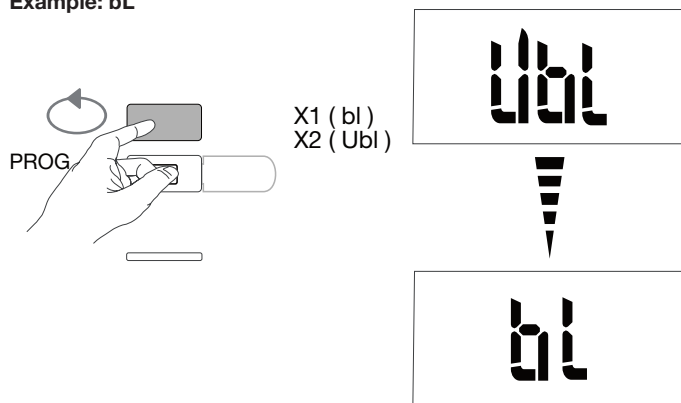

Validate and continue with button C "Prog"

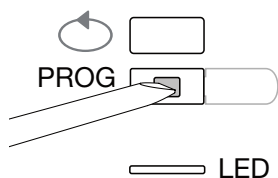

7.2.5.5 Selecting manual / automatic mode

Press button B repeatedly to scroll and select the manual mode

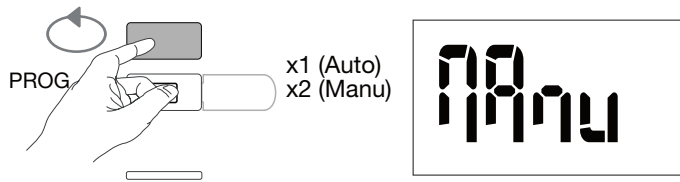

Validate and continue with button C "Prog"

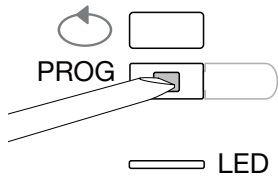

7.2.5.6 Communication address

Scroll with button B to select the address

Example: Addr = 012

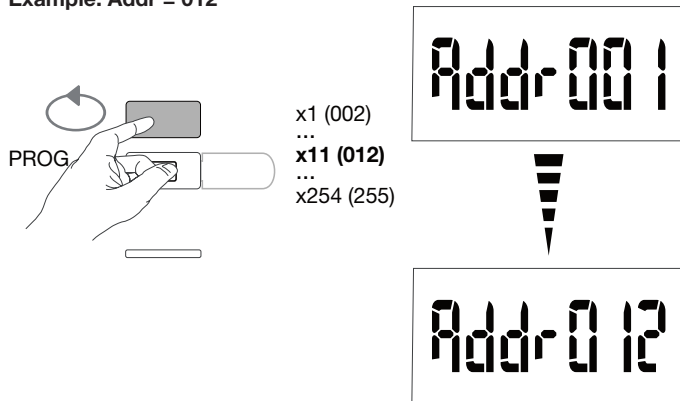

Validate and continue with button C "Prog"

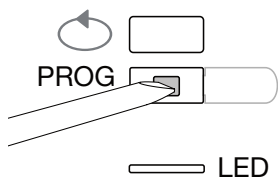

7.2.5.7 Setting the transfer rate

Scroll with button B to select the transfer rate

Example: bd = 19200

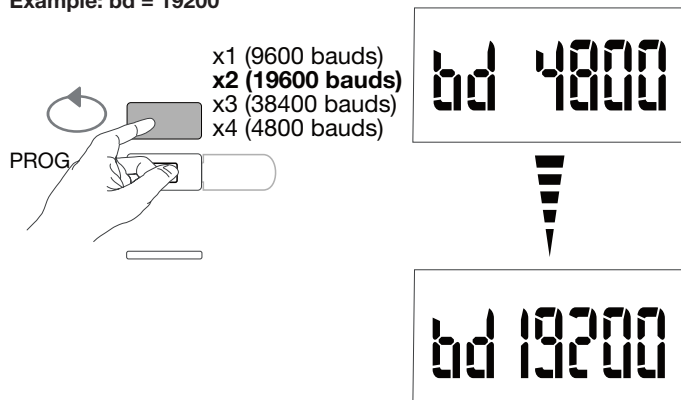

Validate and continue with button C "Prog"

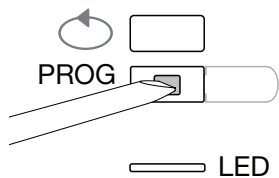

7.2.5.8 Setting the communication parity

Scroll with button B to select the parity

Example: Par = odd

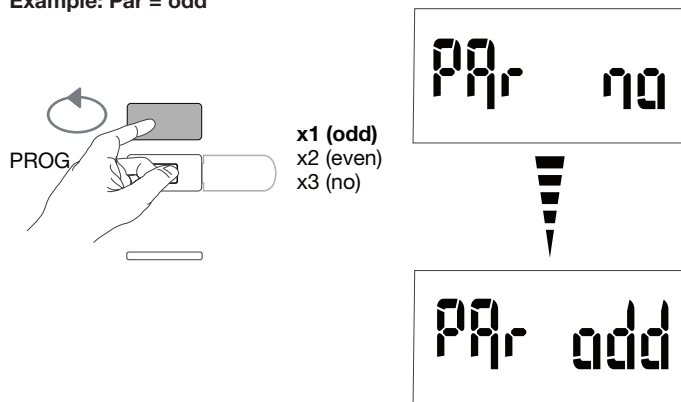

Validate and continue with button C "Prog"

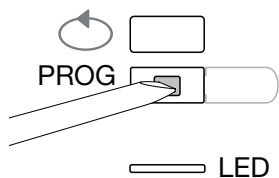

7.2.5.9 Setting the communication stop bit

Scroll with button B to select stop bit 1 or 2

Example: STOP = 2

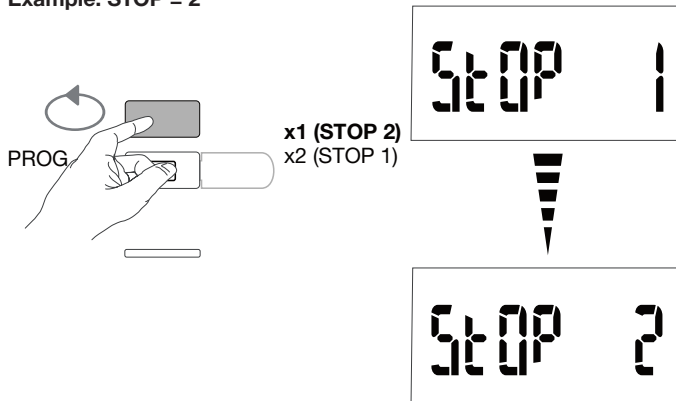

7.2.5.10 Quit and save programming

Press button C "Prog" for at least 5 seconds

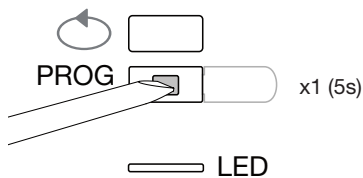

Warning

The programming level is exited automatically after two minutes if no input is made. Changes will not be saved!

7.2.5.11 Function test for the electrical wiring connections

The energy meter must be connected to the voltage supply and a load must be connected. This function can only be used if the power factor of the installation is between 0.6 and 1 and minimum current consumed on each phase = 20 % In.

Press and hold button B for at least 3 seconds.

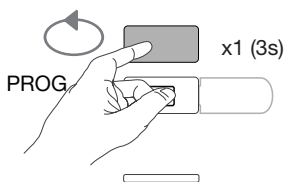

The messages below indicate you the connection status of phases in the meter device.

Error	Error description
Err 0	no error
Err 1 / 2 / 3	Reverse polarity of current transformer on phase 1/phase2/phase3
Err 4	Reversed polarity of voltage between V1 and V2
Err 5	Reversed polarity of voltage between V2 and V3
Err 6	Reversed polarity of voltage between V3 and V1
Err 7	reversed connection of voltage between V1 and neutral conductor
Err 8	reversed connection of voltage between V2 and neutral conductor
Err 9	reversed connection of voltage between V3 and neutral conductor

Press button B for at least 3 seconds to exit this mode.

7.3 Electrical pulses concentrator EC700

7.3.1 Commissioning the EC700

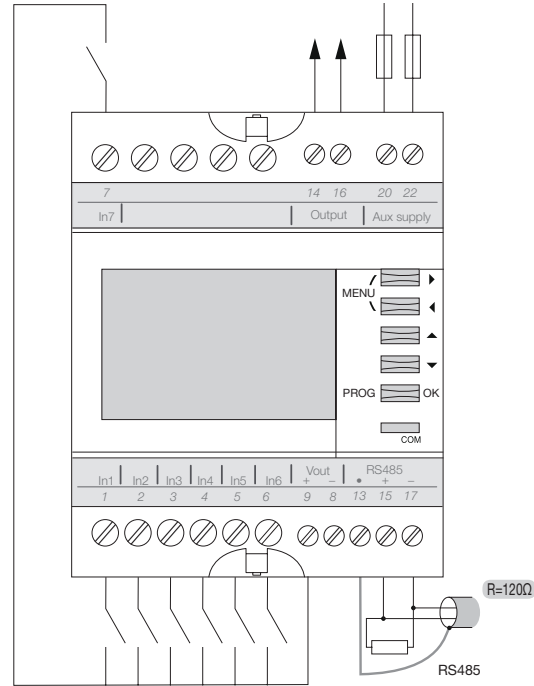
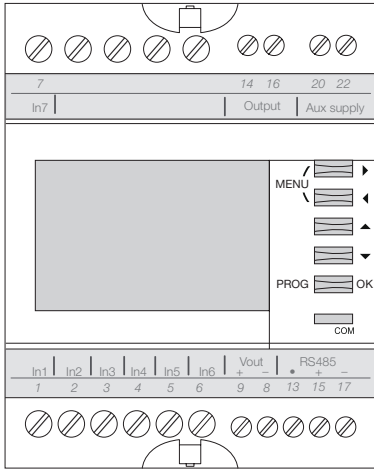

Make sure that the different connections are properly connected as above, before you switch on the device. (For the complete programming, please refer to the EC700 user instructions)
If the concentrator is integrated into the RS485 daisy chain network as first or terminal device, the resistor 120 Ω provided must be connected between the terminals 15 - 17 "+" and "-" as showed on the picture.

7.3.2 Access to programming mode

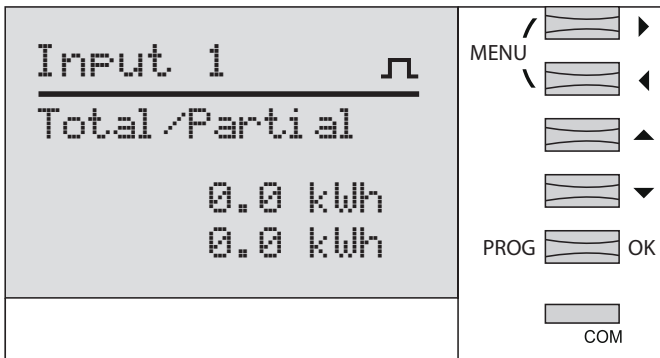

Press button "PROG" for at least 3 seconds to access configuration mode

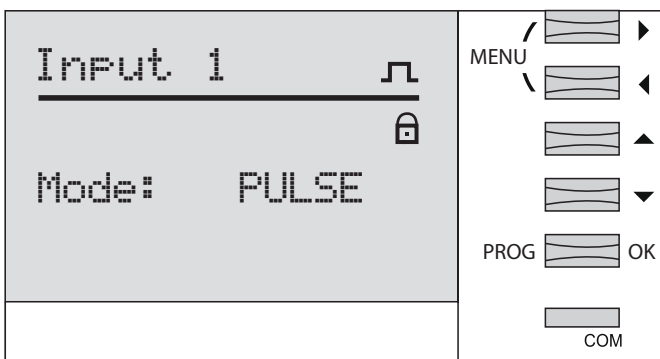

7.3.3 Access to JBus/Modbus menu

Scroll with button  to select the JBus/Modbus menu, and validate with button "OK"

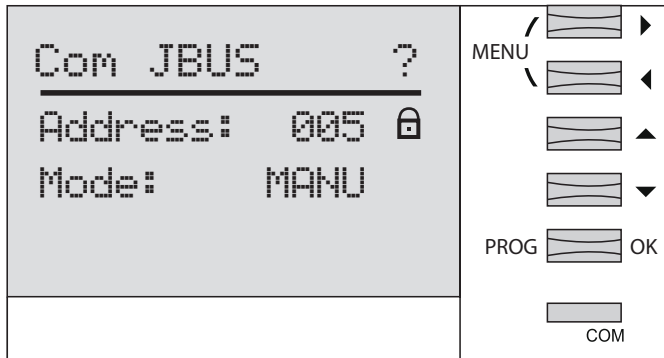

7.3.3.3 Communication address

Scroll with the 4 buttons  to select the address (2-247), and validate with button "OK"

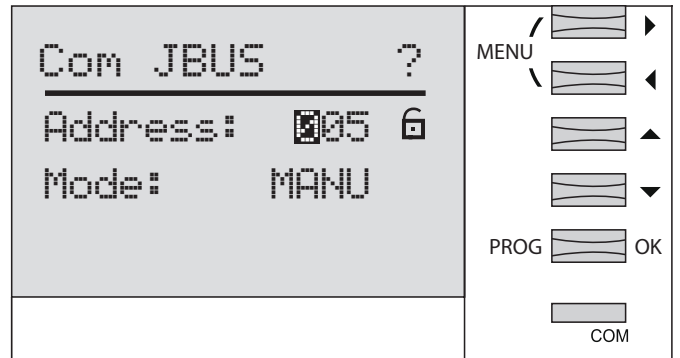

7.3.3.2 Enter the pass code 1000

with the button  and validate with button "OK"

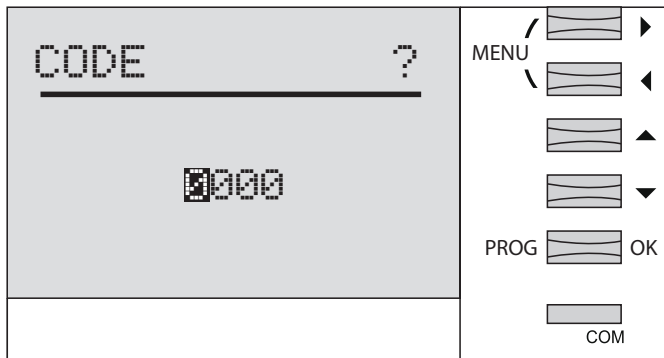

Press again the button "OK"

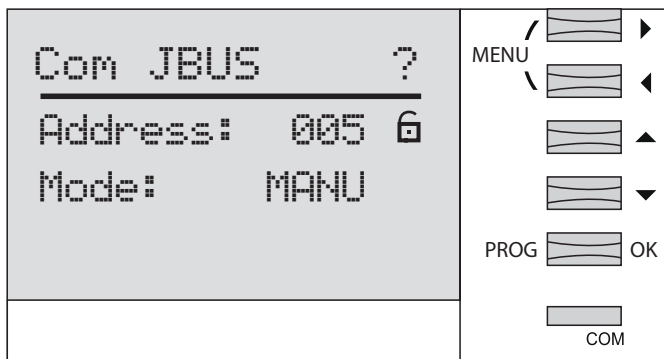

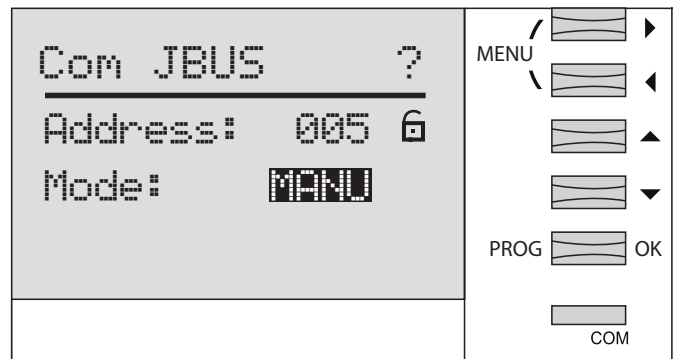

7.3.3.4 Selection manual mode

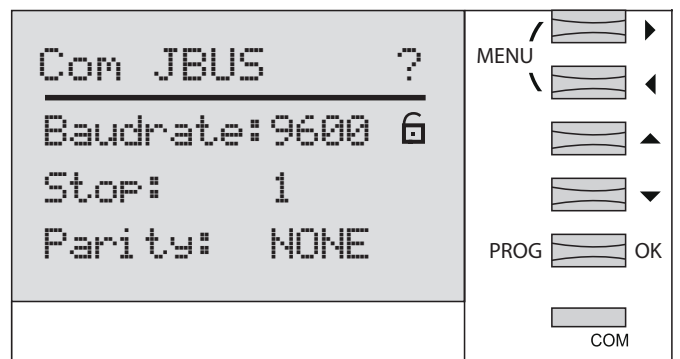

Validate the manual mode with button "OK" and press again the button "OK"



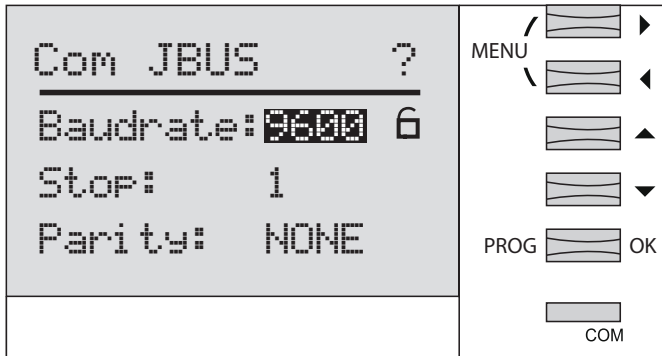

7.3.3.5 Setting the transfer rate

Scroll with the buttons   to select the transfer rate 9600-19200-38400 bauds, validate with button "OK"



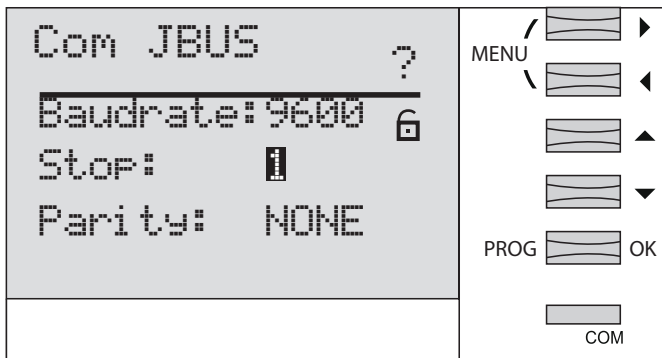

7.3.3.6 Setting the communication stop bit

Scroll with the buttons   to select stop bit 1 or 2, validate with button "OK"



7.3.3.7 Setting the communication parity

Scroll with the buttons   to select none, even, odd, validate with button "OK"

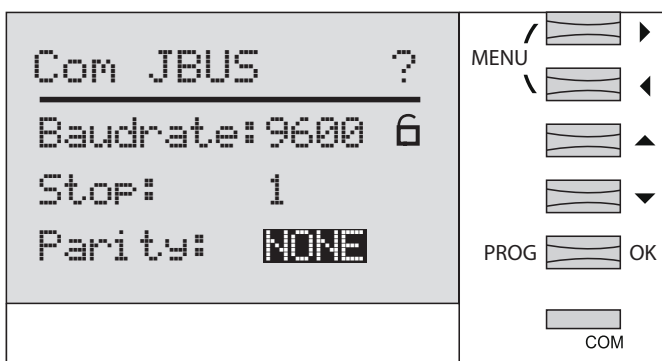

Press button "OK" for at least 3 seconds to save and quit programming mode



The programming level is exited automatically after two minutes if no input is made. Changes will not be saved!

7.4 Commissioning of the Communication Module HTC3x0H for MCCB h3+ Energy

The Communication Module of the HTC3x0H series allows you to communicate all data recorded by the MCCB h3+ Energy to a compatible data collection system Modbus RTU. It is especially indicated to interface with agardio.manager HTG411H.

Check that the power supply and the different connections are correctly connected before putting the device into operation. If any doubt, please refer to the HTC3x0H instruction manual.

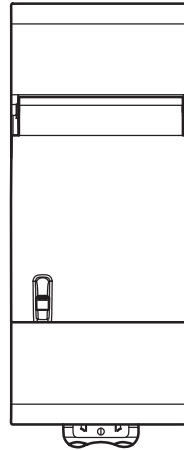

Architecture



agardio.manager

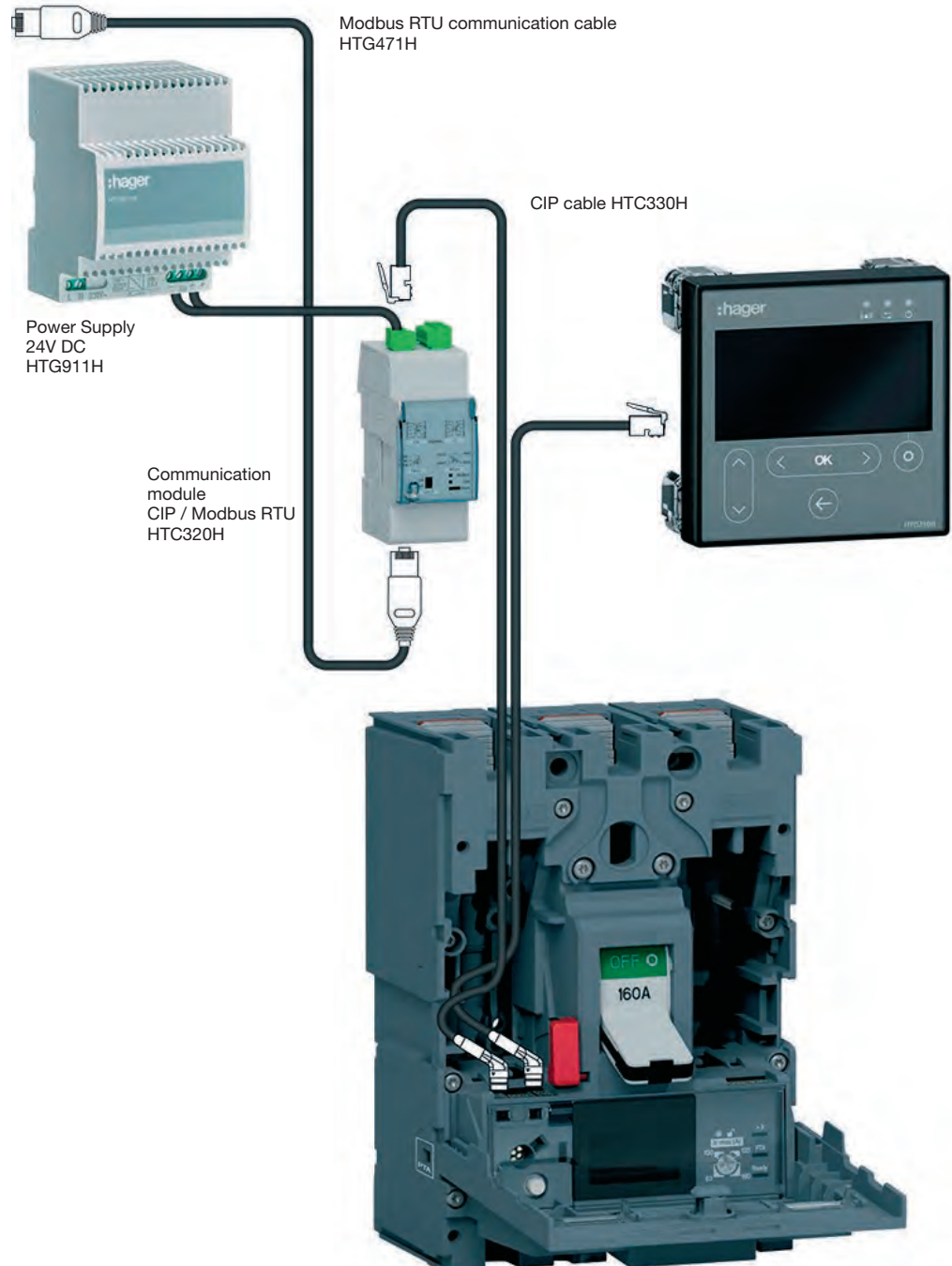

7.4.1 Setting of communication module

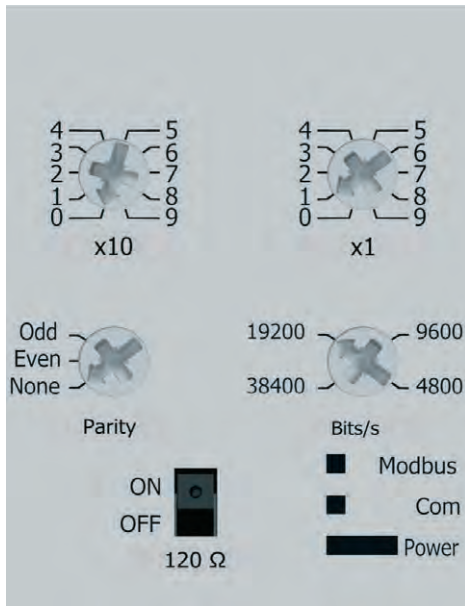

The Modbus parameters are adjustable on the front panel by rotary switches:

- Modbus address from 1 to 99
- Parity
- Speed in BAUD

The Modbus communication module integrate a 120 Ω resistor to integrate a termination impedance into the Modbus chain.

This resistor can be activated / deactivated via a switch in front.

There are two versions: with or without input and output digital inputs.

HTC310H: without input and output contacts.

HTC320H: with 2 digital inputs contacts and 2 contacts digital outputs.

Default setting of the communication module

Modbus address = 1
Bus speed: 19200 BAUD
Parity: pair
120 Ω resistance: ON enabled

7.5 Power Factor Correction Controller SPC06HM

The PFC controller is composed of 2 parts, the display which is flush mounting on the cabinet door, and the main casing which is a rail mounting product. The RJ12 connection cable between the 2 products is provided and must be connected.



Before switching on the device, please check that the backup battery (Lithium CR2032), in the main casing product, has been built in. Otherwise, all stored data would be lost in case of a power failure.

- ① Disconnect the device from the supply voltage.
- ② Lift the upper housing cover with a suitable tool (e.g. a small screwdriver).
- ③ If not built in, push the battery into the clamping bracket and make sure that it is inserted correctly and has the right polarity. The (+) must be in front of you.
- ④ Put the upper housing cover back on and click it into place by pushing.
- ⑤ Reconnect the device to the supply voltage.

Make sure that the power supply and the different connections are properly connected on the main casing. If you have a doubt, please consult the SPC06HM instruction manual.

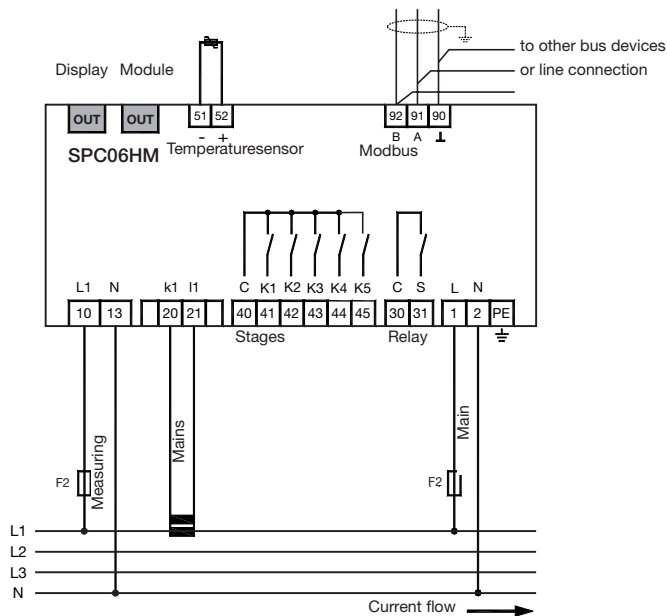

Modbus connection:

- Terminal 91: A (-)
- Terminal 92: B (+)
- Terminal 90: Common (not Ground)

Reminder : If the controller is integrated into the RS485 daisy chain network as first or terminal device, a 120 Ω resistor must be connected between the terminals 91 - 92 "A" and "B".

7.5.1 Power factor display panel

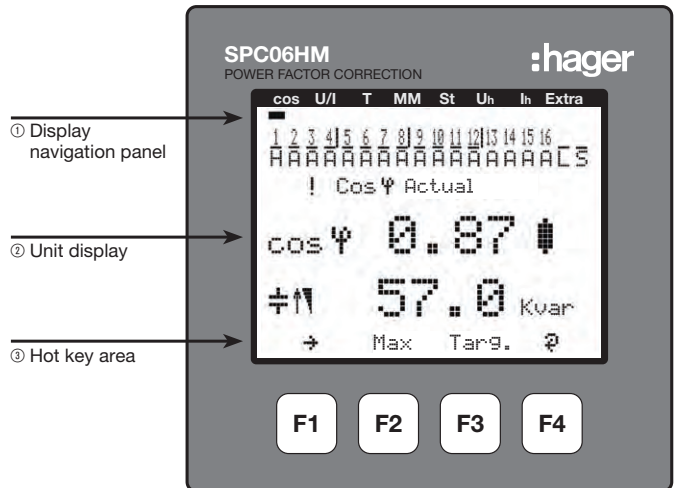

Description of buttons and displays

- ① Display navigation panel
The navigation panel shows the main menu selected.
- ② Unit display
In use mode, the display shows the measured values. In programming mode, the display area is used to show the menu and sub menus.
- ③ Hot key area
The text line corresponds to the respective function keys and is used to issue messages and text.

F1 to F4 are sensitive touches

7.5.2 Programming menu structure

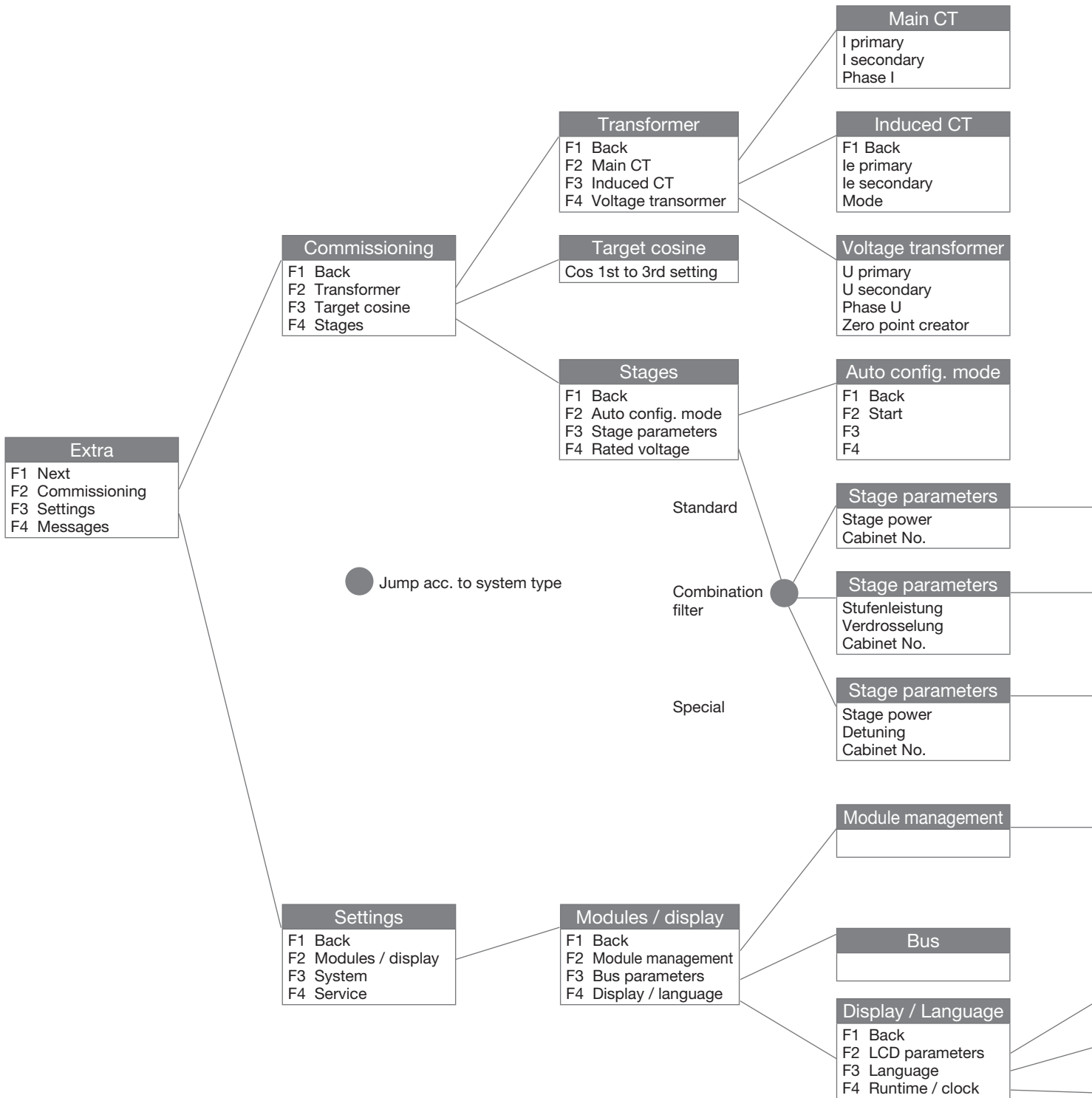

The access to the Modbus programming is as following:
- Main Menu : "Extra", "Settings", "Modules / display" "Bus parameter"

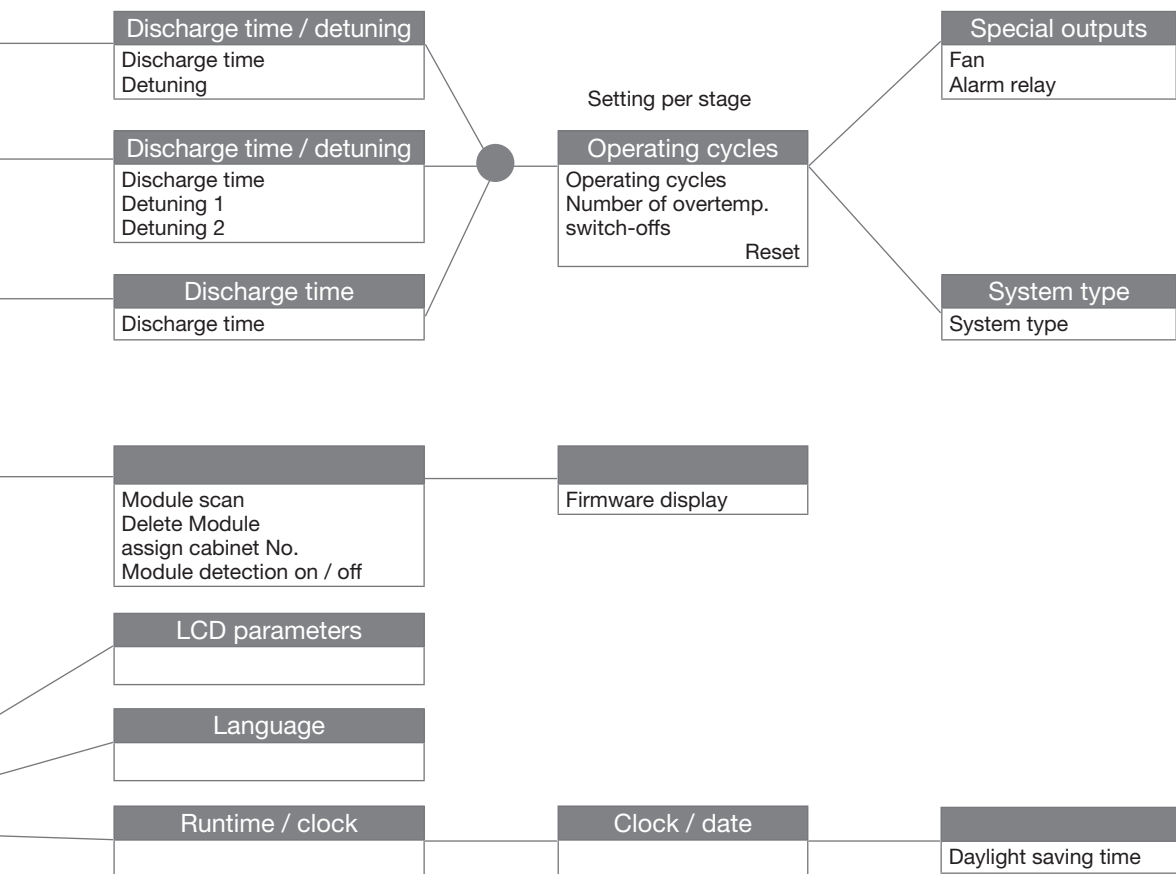

7.5.3 Access to main menu "Extra"

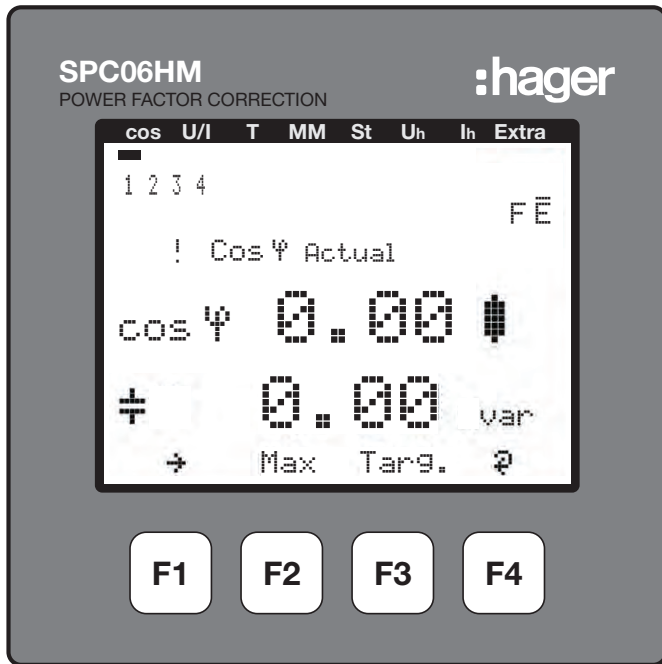

Scroll with F1 through main menu, from "cos" or other menus up to "Extra"

7.5.4 Access to sub menu "Settings" touch F3



7.5.5 Access to sub menu "Modules / display" touch F2

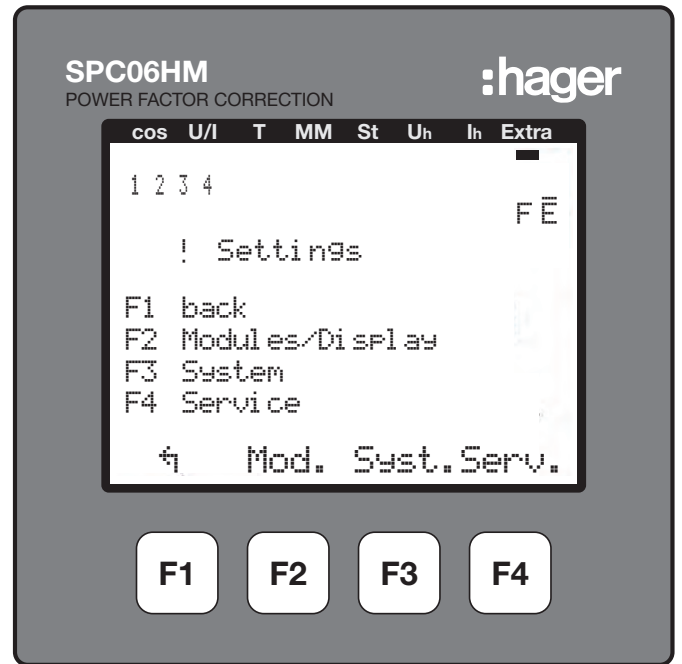

7.5.6 Access to sub menu "Bus Parameter" touch F3

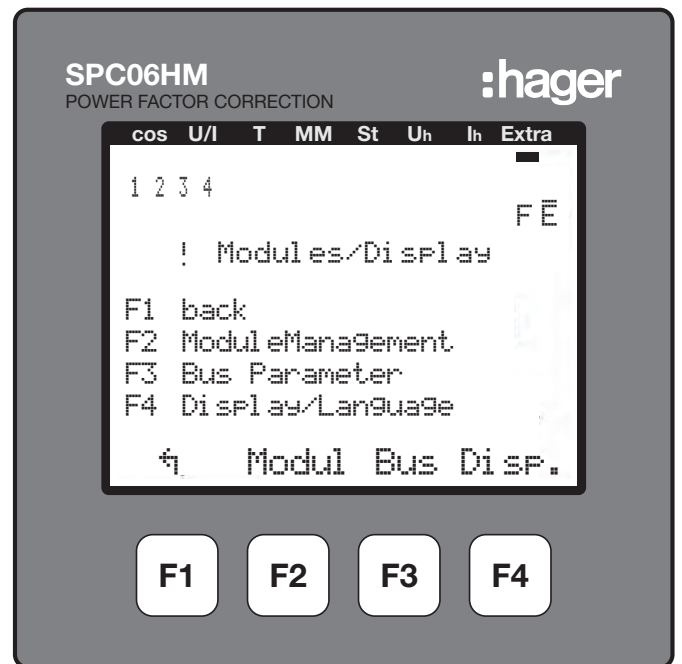

7.5.7 To select Modbus touch F4 "EDIT"

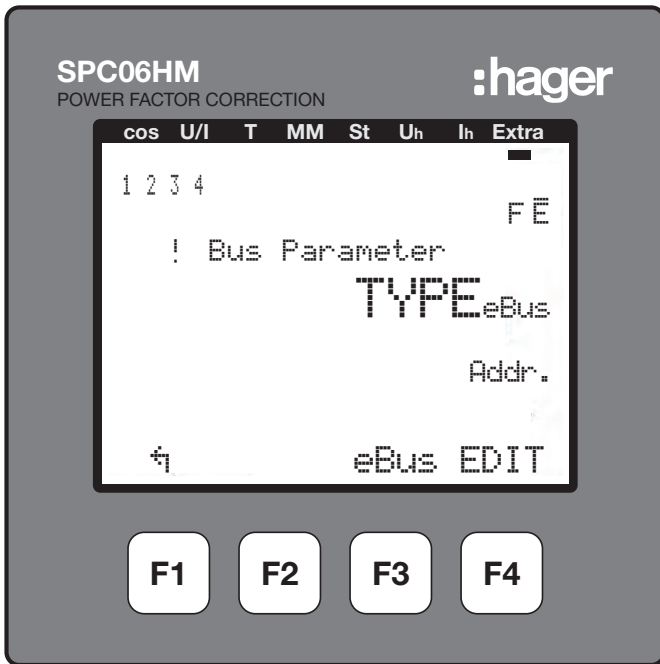

Validate with touch F2 "YES"

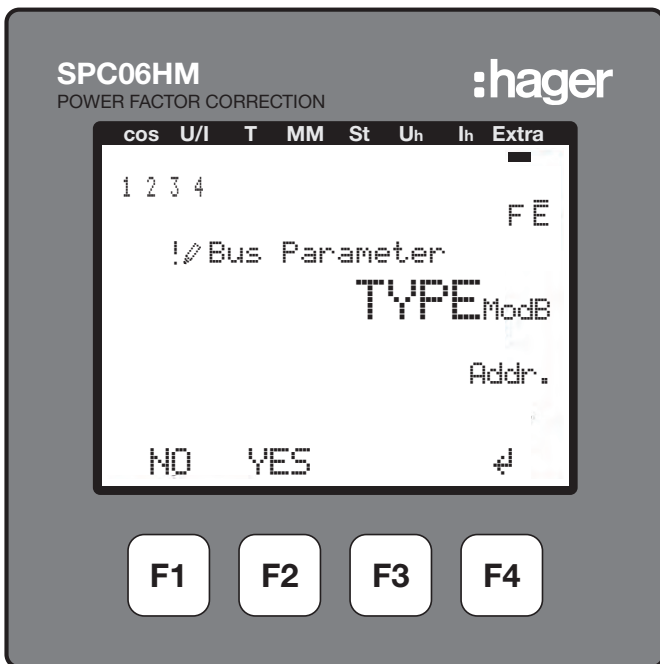

The controller saves the changes and reboots the system.

Note: during this operation, the connected capacitor stages are switch-off and reconnected automatically.

After rebooting, the controller displays the sub menu "Commissioning". To come back to the Modbus programming, press successively, touch F1, F3, F2, F3.

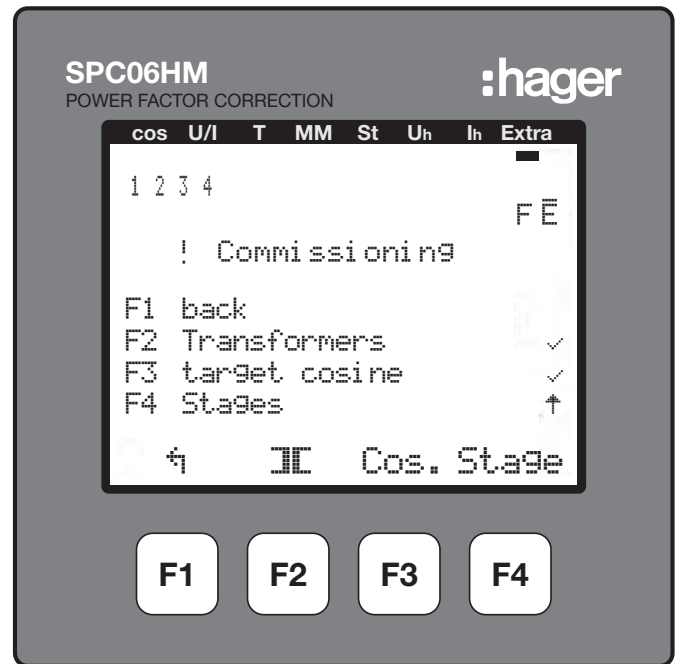

7.5.8 Access to Modbus menu touch F3 "ModB"

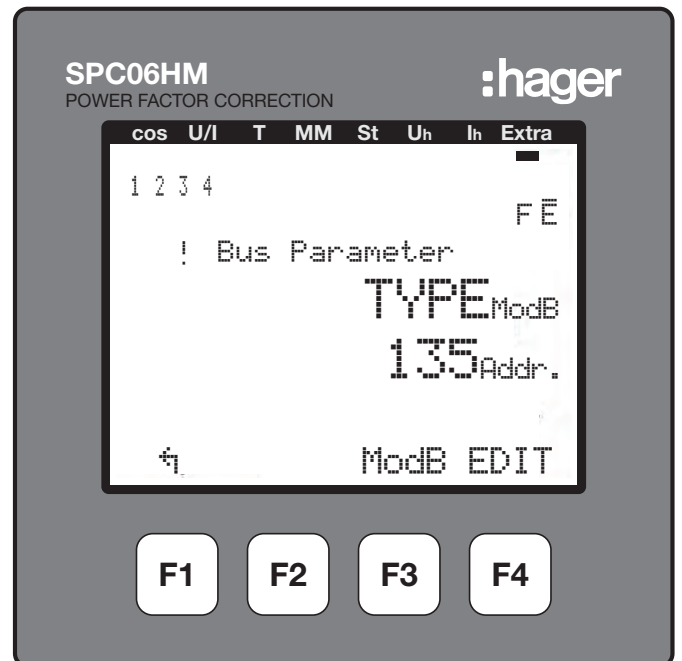

7.5.9 To enter in the Modbus settings touch F4 "EDIT"

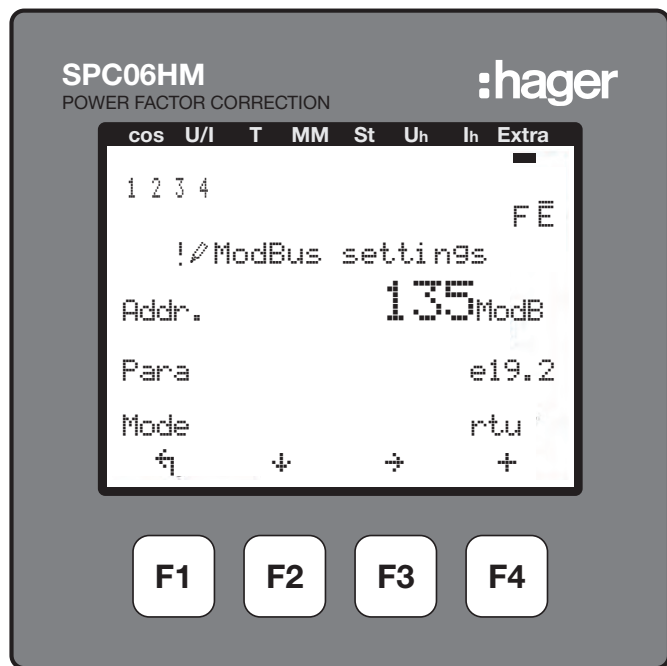
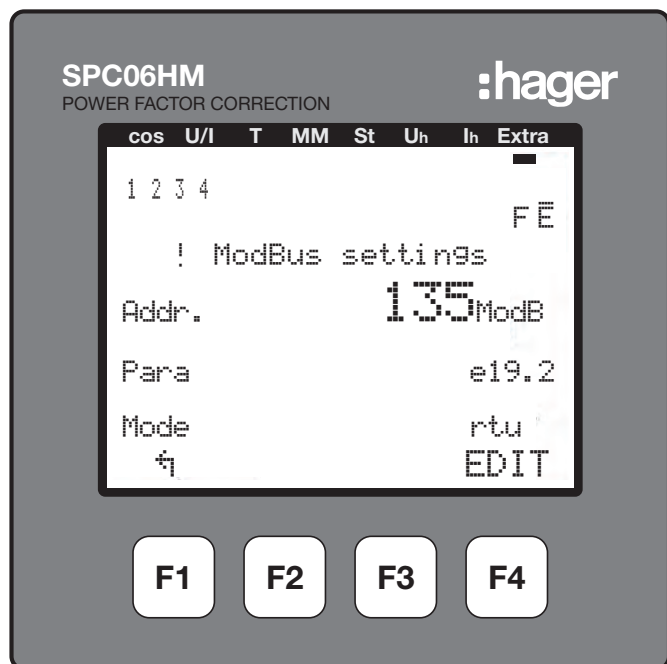

F1 : back to previous menu

F2 : ↕ scroll to go to line 2 (Para.) or line 3 (Mode)

F3 : → scroll to go to the next digit

F4 : + increase the value

7.5.10 Setting the communication address

Touch F3 (→) select the first, second or third digit, and with F4 (+) increase to the desired value, than go to the line 2 (Para.) with the touch F2 (↕)

7.5.11 Setting the communication parity and transfer rate

The transfer rates are 4.8, 9.6 and 19.2kBds. Each transfer rate is associated with the 3 parities possibilities, e = even, n = no, o = odd, the letter is displayed before the transfer rate.

Scroll and select the couple parity/transfer rate with F4, than go to the line 3 (Mode) with F2 (↕)

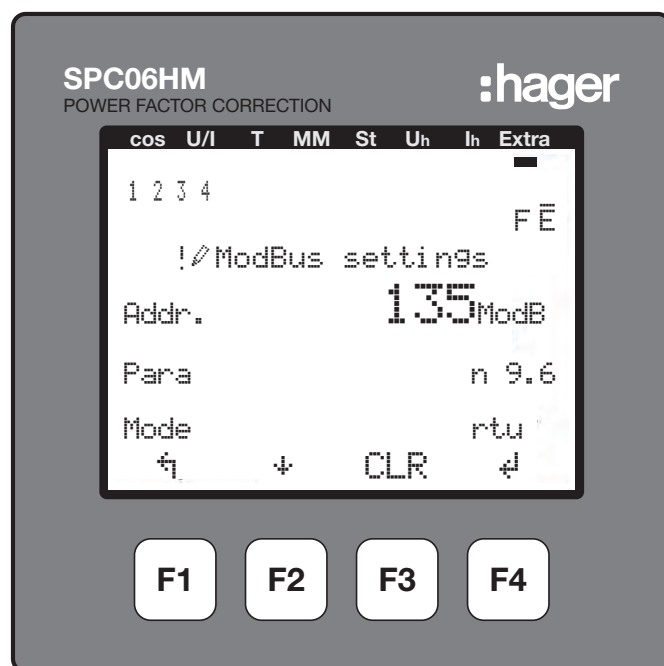

7.5.12 Setting the Modbus mode

The Modbus mode must always be "rtu". If "ascii" is displayed, please change to "rtu" mode with F4.

Validate with F3 "YES"

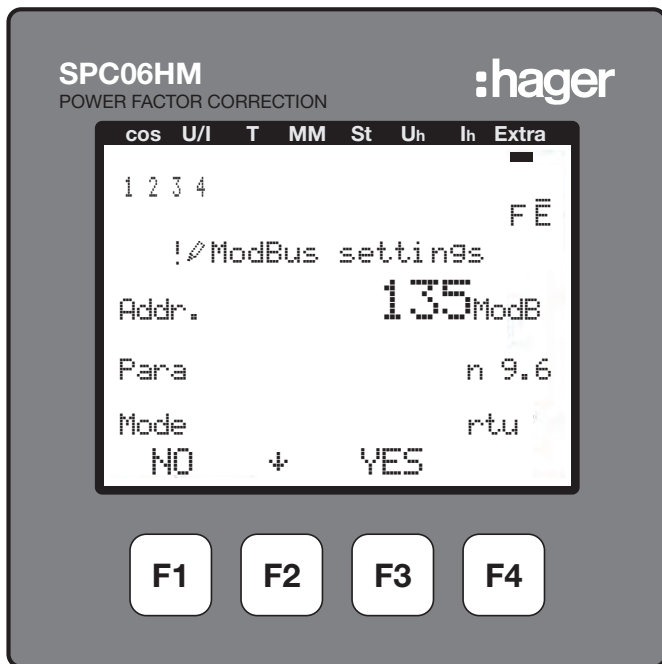

The controller saves the changes and reboots the system.
Note: during this operation, the connected capacitor stages are switch-off and reconnected automatically.

Remark: The stop bit (1 or 2) is automatically set by the controller.



Warning

The programming level is exited automatically after two minutes if no input is made. Changes will not be saved!

7.6 Air Circuit Breaker

The Modbus communication is an option available on the Over Current Release type AGR-21, 22 and 31.

7.6.1 Commissioning the A.C.B

Make sure that the power supply and the different connections (power and command) are properly connected before you switch on your installation and circuit breaker. If you have a doubt, please consult the ACB instruction manual.

Modbus terminals position and connections:

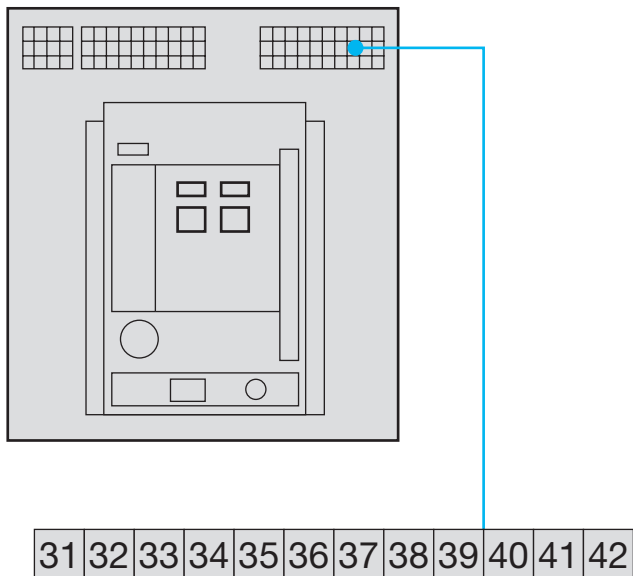

- 41: A (-)
- 42: B (+)
- 32: Ground (cable shield connection)

Reminder : If the ACB is integrated into the RS485 daisy chain network as first or terminal device, a resistor 120 Ω must be connected between the terminals 41/42 “-” and “+”.

7.6.2 A.C.B display panel

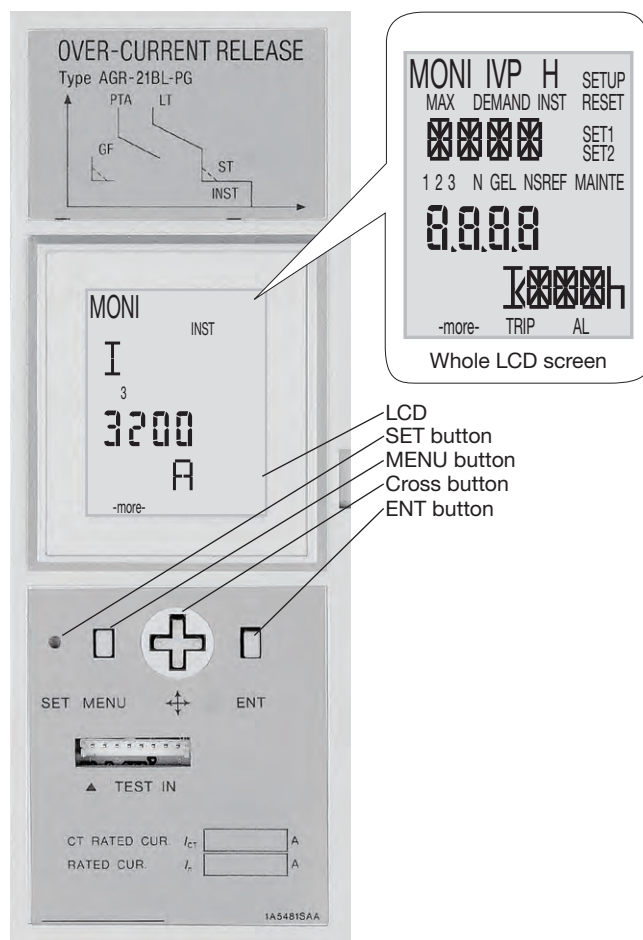

- Ⓢ: Press the SET button using a pointed tool such as the tip of a pen.
- Ⓜ: Press the MENU button.
- ⬆: Press the up key of the cross button.
- ⬇: Press the down key of the cross button.
- ⬇: Press the right key of the cross button.
- ⬅: Press the left key of the cross button.
- Ⓜ: Press the ENT button.

7.6.3 Access and programming menu structure

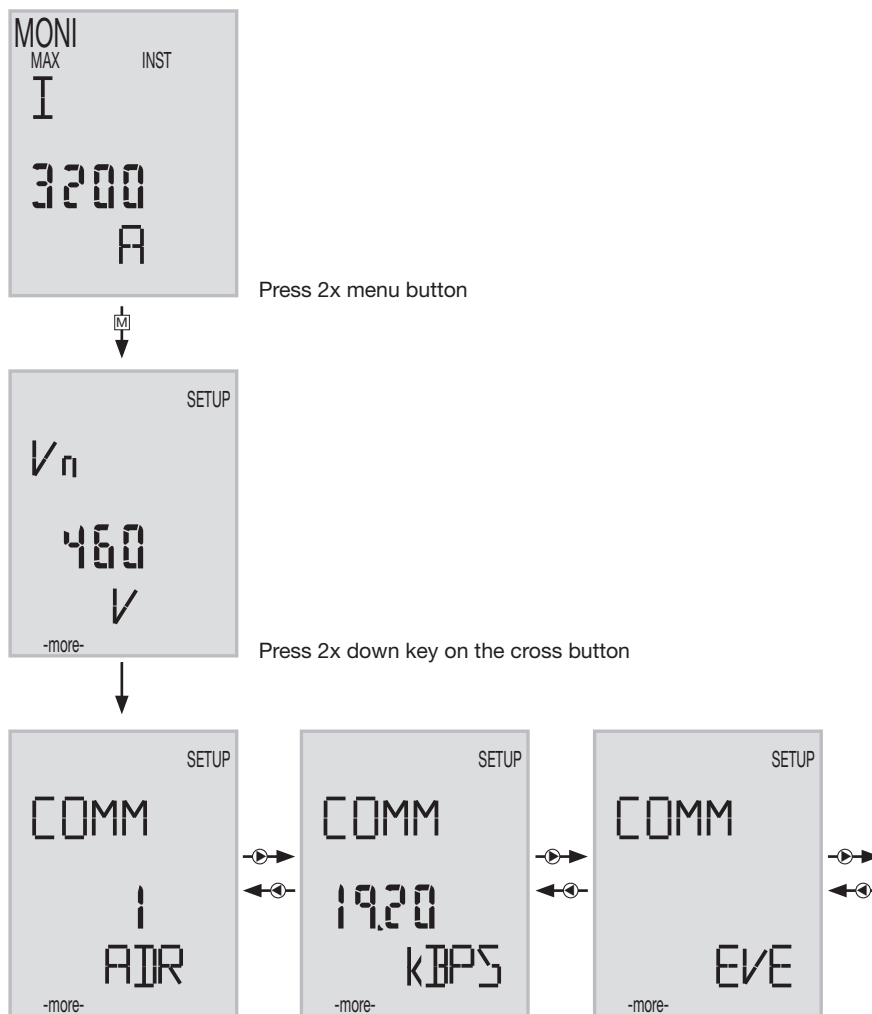

7.6.4 Access to communication address

The address must be selected between 01 and 31, (preferably not 01).

Press "ENT" enter.

The ten's digit of the communication address will flash. Use the up or down key (▲▼) of the cross button to change the digit. After changing the ten's digit, press "ENT".



The unit's digit of the communication address will flash. Scroll with (▲▼) to change the digit. After changing the unit's digit, press "ENT". "SURE" will start flashing, press "SET" to save the modification.

If a communication address other than 01 to 31 is entered, and "SET" is pressed, the address setting will not change. The ten's digit of the communication address will flash, the OCR stays in setting change mode.

7.6.5 Setting the transfer rate

Press the right key  to select the transmission rate display.





Press "ENT" to access to the different values, scroll with   to select the chosen transfer rate (4.8-9.6-19.2kBds), press "ENT". "SURE" will start flashing, press "SET" to save the modification.

7.6.6 Setting the communication parity

Press the right  key to select the communication parity display,



Press "ENT" to access to the different values, scroll with   to select the chosen parity (Even, odd, none), press "ENT". "SURE" will start flashing, press "SET" to save the modification.

Remark: The stop bit (1 or 2) is automatically set by the A.C.B.

Press several  menu to come back to the main display.



Note

After transfer rate or communication parity modification, you must switch Off/On the ABC (red/green push buttons on the front face) for the saving of the modification.

7.7 Automatic Transfer Switch HIC4xxE

7.7.1 Commissioning the HIC4xxE

Make sure that the power supply and the different connections (power and command) are properly connected before you switch on your installation and the Automatic Transfer Switch. If you have a doubt, please consult the quick start instruction sheet.

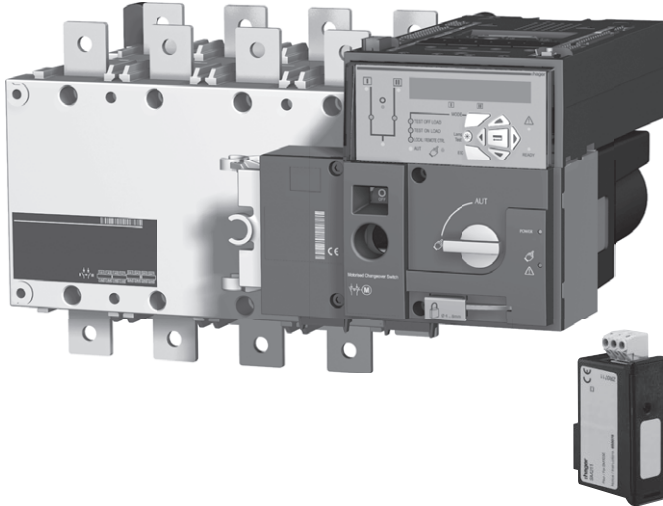

Warning

Connect the modules with the power off. Ensure that the option fixing bolts are tightened correctly. A 3 minute power outage is required to recognize an optional module.

If the device is located at the beginning or termination of the Modbus line, the 2 dip-switches on the communication module must be set on the "ON" position for the resistance activation.

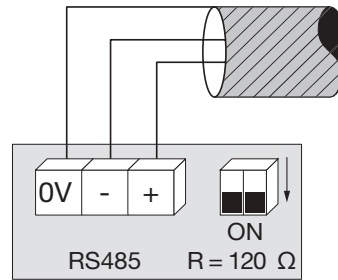

(0V terminal is a cable shield connection and not common)



Warning

Before switching on, the HIC4xxE, the Modbus module SM211 is too fitted on the top of the A.T.S.

Top view ATS control unit, the Modbus module is to be mounted in one of the 4 slots provided in the ATS.

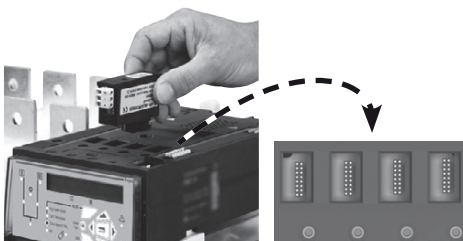
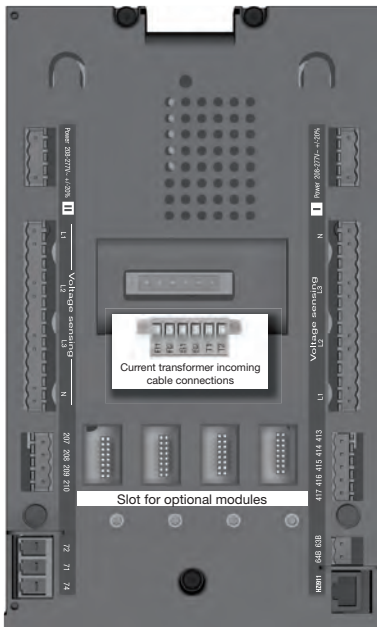

7.7.2 Programming mode

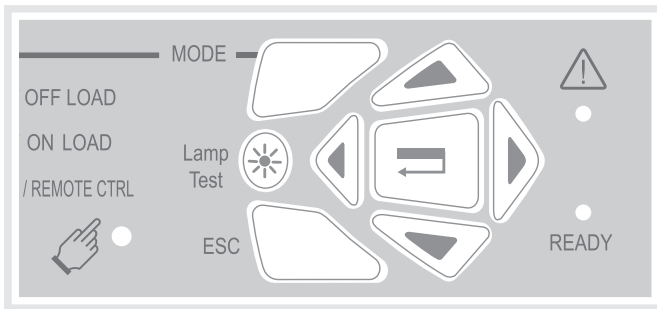

Programming access is possible in automatic or manual mode, when the product is in a stable position (I, 0 or II) with at least one supply source available.

Programming is not accessible whilst any cycle sequence is running.

Navigation in the programming menu



- To enter the programming menu press and hold the validation key until "SETUP" appears on the screen



or



- For parameter access: Press the "up - down" or "left - right" keys to navigate.

Programming



- Navigate to the parameter to be changed and press the validation key.

Note: The product will request a password



- Input the password by using the "up - down" keys to change the value and the "left - right" keys to change the cursor position. (The default factory setting is 1000).
- Press the validation key to validate the password and enable programming.

+



+



- Change the parameter value by using the "up - down" keys to change the variable and the "left - right" keys to change the cursor position.
- Press the validation key to validate the change
- if necessary, navigate to other parameters in the menu, change the value and validate each change.
- To save all changes, press and hold the validation key until "SAVED" is displayed.

+



+



Note: After saving, "SAVED" will be displayed for 2s, the product will automatically exit programming mode and will then return to the main menu.

Exiting programming mode without saving



- To quit programming mode without saving briefly press the "ESC" key. This will allow navigating back to the main menu.

Note: Whilst in programming mode, should the product remain idle for longer than 2 minutes it will automatically exit and return to the main menu without saving.

7.7.3 Overview programming menu structure



Note: the Comm menu is only visible and accessible when the Modbus module is installed.

The minimum configuration parameters that must be programmed or checked before use are:

Setup menu: Type of network (default setting: 4NBL), nominal voltage (default setting: 400V), nominal frequency (default setting: 50Hz)

1	SETUP
NETWORK	4NBL
AUTOCONF	NO
NEUTRAL	AUTO
ROT PH.	---
NOM. VOLT	400 V
NOM. FREQ	50 Hz

3 phase / 4 wire	3 phase / 3 wire	2 phase / 3 wire	2 phase / 2 wire	1 phase / 2 wire

7.6.4 Modbus programming menu and parameters

7	COMM
ADDRESS	005
BDRATE	9600
STOP BIT	1
PARITY	NONE (Default value)

Has to be set:

- The communication address: select an address between 2 and 247
- The transfer rate: select the baud rate 9600, 19200 or 38400Bds.
- The communication stop bit: 1 or 2
- The communication parity: select EVE (Even parity) ODD or NO parity.

8. Accessories

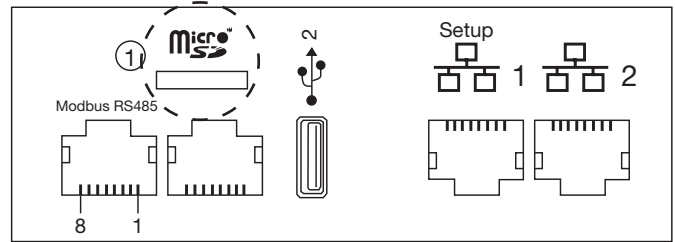
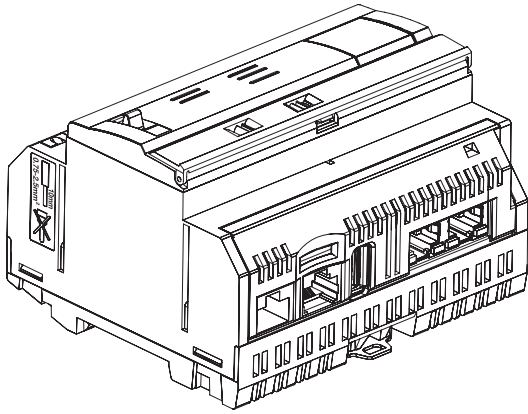

8.1 Micro SD card store reference HTG450H, suitable for industrial applications

The μ SD card is used to store information (configuration and data). Without the μ SD card inserted, the energy server does not start.



Warning

In case of replacement, the energy server must be switch off, before the μ SD card extracting. The μ SD card slot is located in the lower part of the energy server. In case of replacement of the energy server, the μ SD card could be removed from the current energy server and placed within the new one in order to re-start with all configuration and data.

Capacity	4GB
Category	SDHC
Speed class	10
Speed grad	3
Operating temperature	-40 to +85°C

8.2 USB / Ethernet cable reference HTG457H

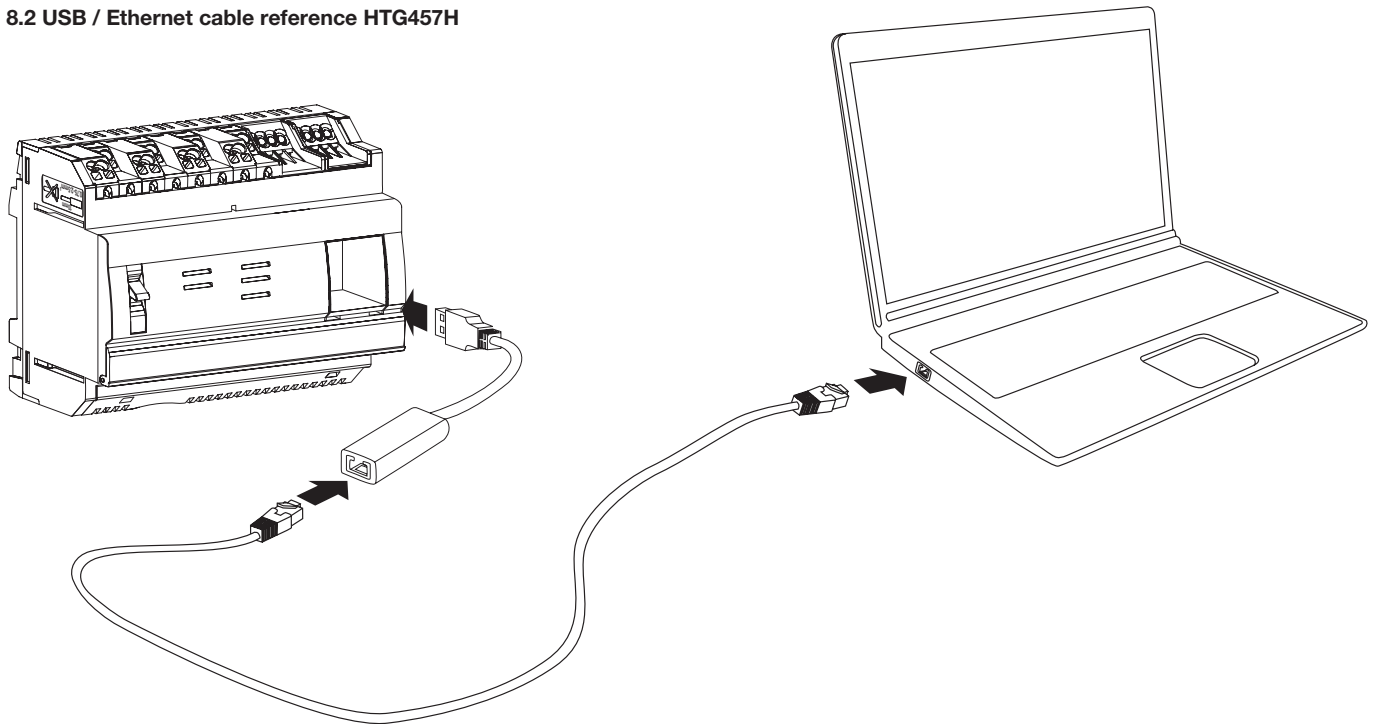

The HTG457H is a USB to RJ45 Ethernet interface, especially suitable for local connection with the HTG410H using a computer. It allows direct connection on the front panel, avoiding any dismantling of box or cabinet. The USB port acts as an 'Ethernet over USB'. This configuration is used when the access to Ethernet 1 is not possible.

Implementation

Ensure that the Ethernet network installation is not connected on the port "Setup - Ethernet1", but on the Port "Ethernet 2".

Note: In "Setup ON" mode, the HTG410H activates its DHCP server on "Setup - Ethernet 1" port.

- ① Put the "Setup" switch in "ON" position on HTG410H.
- ② Execute a reset for the HTG410H by switching off/on the power supply.
- ③ Wait until the "Power" LED is fixed green.
- ④ Connect the accessory USB port on the USB port located on front of HTG410H.
- ⑤ Connect the Ethernet port of the HTG457H to the Ethernet port of the computer with an Ethernet cable (crossed / uncrossed).
- ⑥ Set the TCP/IP connection on the computer:

Example for Windows 7 Professional:

- Open "Network and Sharing Center".
- Click on "Change adapter settings".
- Click on "Local Area connection".
- Click on "Properties".
- Select "Internet Protocol Version 4 (TCP/IPv4)" and click on "Properties".
- On "General" tab, make sure "Obtain an IP address automatically" and "Obtain DNS server address automatically" are checked. Otherwise, write down your current settings before making any changes, and check the 2 boxes.
- Click on "OK" to close window "Internet Protocol Version 4 (TCP/IPv4) Properties".
- Click on "Close" to close window "Local Area Connection Properties".

- ⑦ Activate the Web browser on the computer.
- ⑧ Enter 192.168.2.1 as the url and connect you to the product HTG410H as usual.

Total disconnection.

- ① Exit SETUP mode by selecting "Setup" switch in "OFF" position.
- ② Disconnect the accessory on USB port.
- ③ Restart HTG410H by switching off/on the power supply.
- ④ If applicable, reset the TCP / IPv4 settings on the computer - those recorded before modification.

8.3 USB / Wifi interface reference HTG460H

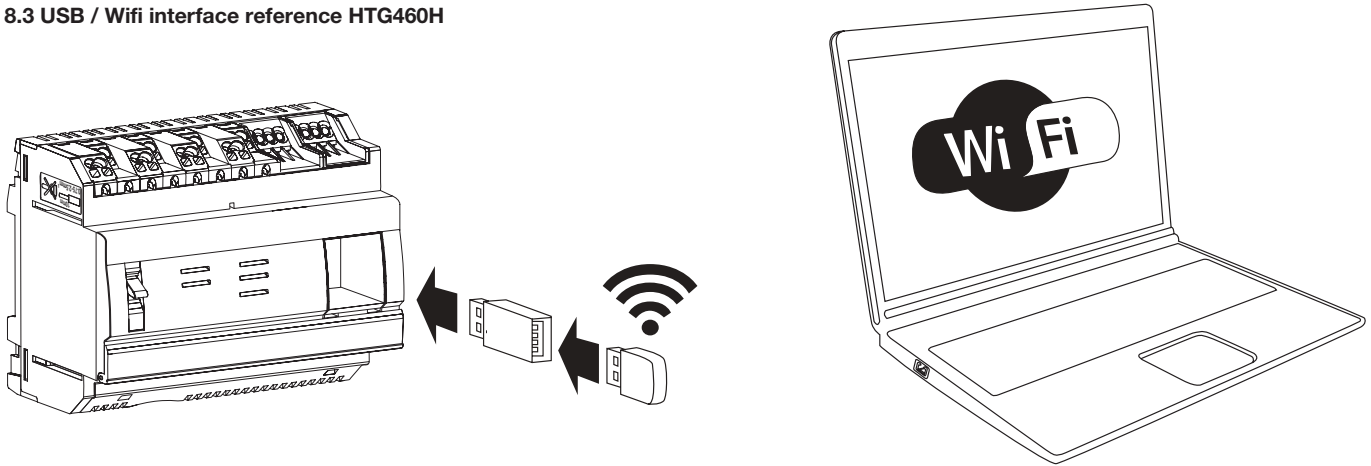

The HTG460H is an USB to WiFi interface, especially suitable for the connection without wire with the HTG410H. It allows direct connection on the front panel, avoiding any dismantling of box or cabinet. This is the easiest mean to connect a computer or tablet.

Implementation

Ensure that the Ethernet network installation is not connected on the port "Setup - Ethernet1", but on the Port "Ethernet 2".

Note: In "Setup ON" mode, the HTG410H activates its DHCP server on "Setup - Ethernet 1" port.

- ① Put the "Setup" switch in "ON" position on HTG410H.
- ② Execute a reset for the HTG410H by switching off/on the power supply.
- ③ Wait until the "Power" LED is fixed green.
- ④ Connect the accessory on the USB port located on front of HTG410H.
- ⑤ Connect to the new WiFi network called "HTG410H" in the WiFi Manager
- ⑥ Enter "HagerHTG410H" for the required security key.
- ⑦ Activate the Web browser on the computer.
- ⑧ Enter 192.168.3.1 as the url and connect you to the product HTG410H as usual.

If unable to connect to the product, contact the computer workstation administrator.

Total disconnection

- ① Exit SETUP mode by selecting "Setup" switch in "OFF" position.
- ② Disconnect the accessory on USB port.
- ③ Restart HTG410H by switching off the power supply and on again.

9. Acronyms

ACB: Air Circuit Breaker

ASCII: American Standard Code for Information Interchange

AWG: American Wire Gauge

DHCP: Dynamic Host Configuration Protocol

DNS: Domain Name System

EIA/TIA: Electronic Industries Alliance – Telecommunications Industry Association

EMC: Electro Magnetic Compatibility

EMI: Electro Magnetic Interference

IP: Internetwork Protocol

MAC address: Media Access Control address

MCB: Miniature Circuit Breaker

MCCB: Molded Case Circuit Breaker

Micro SD HC: Micro Secure Digital Card high capacity and transfer speed

Modbus RTU: Remote Terminal Unit

Modbus on TCP/IP

PLC: Programmable Logic Controllers

PMD: Performance measuring and monitoring devices

SELV: Safety Extra Low Voltage

TCP: Transmission Control Protocol

TCP/IP: Transmission Control Protocol /Internetwork Protocol

USB: Universal Serial Bus

Wi-Fi: Wireless Network



Hager Electro SAS
132 Boulevard de l'Europe
BP3
67210 OBERNAI CEDEX

hager.com