

Installation instructions
Indoor station
video comfort
wall mounted 2wires

GB

Design and layout of the device

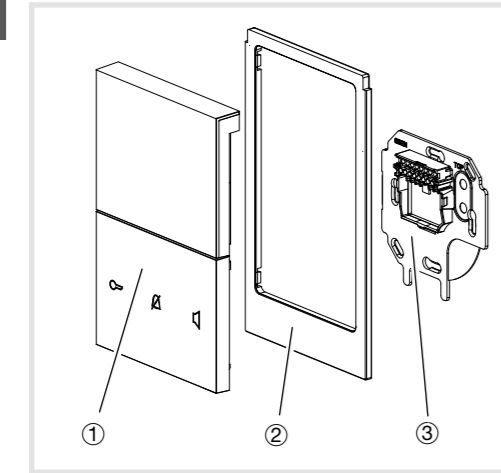

- Figure 1: Design and layout of the device
- ① Indoor station (application module with display and control unit)
 - ② Design frame, large version (only with REK...Y included in scope of delivery)
 - ③ Supporting plate with connection terminal block

Function

The indoor station VIDEO is a device for the 2-wire bus system. It can communicate with door stations and further indoor stations in sound and image and unlock door releases.

Correct use

- For surface-mounting on a flat surface or for mounting on a wall box according to DIN 49073
- Only suitable for use in indoor areas with no drip and no spray water
- Not suitable for video monitoring
- Not compatible with intercom systems of other manufacturers

Product characteristics

- Illuminated 3.5" TFT colour display
- Touch control panel with 3 illuminated symbol buttons and 3 menu operation buttons
- Slide control surface for menu access
- Menu in 5 languages
- Ring tone volume and microphone sensitivity can be adjusted
- Hands-free or Push-to-Talk
- 16 ring tone melodies, individually assignable
- Connection for storey bell push-button
- Storey call forwarding
- Parallel operation (a total maximum of 3 identically addressed indoor stations)
- Internal calls to other indoor stations
- Camera can be switched on manually
- Light relay contact of the bus line power supply controllable

Symbol button	Function	LED State
	Door release button	Unlock door
	<i>lights up</i>	<i>Door can be unlocked</i>
	Mute button	Mute ring tone
	<i>flashes</i>	<i>Ring tone muted</i>
	Speech button	Accept call, End call
	<i>flashes</i>	<i>Incoming call</i>
	<i>lights up</i>	<i>Call in progress</i>

Operation

Display elements and operating concept (Figure 2)

The indoor station video has a display (4) for displaying camera pictures and the device menu. The underlying control panel has 6 buttons and a slide control surface. Each of the 6 buttons on the control panel corresponds to a touch-sensitive surface. To trigger its function, it needs a push-button press with tactile feedback. The touch-sensitive slider (10) responds to horizontal swiping movements.

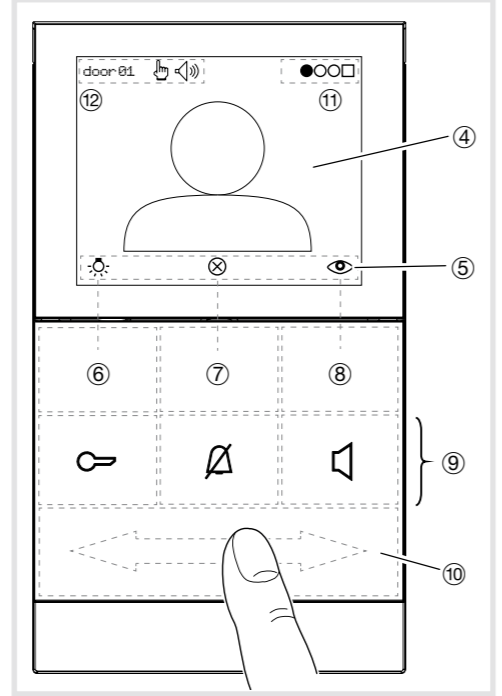

- Figure 2: Operating and display elements
- ④ Display
 - ⑤ Icon bar - displays the current assignment of the three menu operation buttons (⑥, ⑦ and ⑧)
 - ⑥ } Menu operation buttons (Softkeys) (Table 2)
 - ⑦ }
 - ⑧ }
 - ⑨ Symbol buttons - illuminated, with fixed functions (Table 1)
 - ⑩ Menu slider - for menu access and page change
 - ⑪ Menu position display (Table 3)
 - ⑫ Status line

Symbol buttons for main functions

Symbol button	Function	LED State
	Door release button	Unlock door
	<i>lights up</i>	<i>Door can be unlocked</i>
	Mute button	Mute ring tone
	<i>flashes</i>	<i>Ring tone muted</i>
	Speech button	Accept call, End call
	<i>flashes</i>	<i>Incoming call</i>
	<i>lights up</i>	<i>Call in progress</i>

Table 1: Symbol buttons with LEDs

i In addition, the symbol buttons do give an acoustic feedback after actuation (1 acknowledge tone = function available; 3 short tones = function not available).

Switching on device/activating display

The indoor station is in standby mode.

- Press any menu operation button (⑥, ⑦ or ⑧).
- An acknowledge tone sounds and the display is initialised. After a slight delay, the start page with a light and switch off symbol appears on a black background or with a video image depending on the configuration (**manual**).

i If the device has been configured for internal calls, the menu page **special functions** appears instead of the start page.

- During an incoming call, the device switches on automatically.

Menu operation buttons (Softkeys) and icon bar

The functions displayed in the icon bar (5) are triggered with the menu operation buttons (⑥, ⑦, ⑧) (Table 2).

Softkey	Symbol	Function
⑥		Switch on light ^{1), 3)}
		Selection/scroll down
		Setting/decrease value
⑦		Return ⁴⁾
		Switch off display (Stand-by)
		Selection/scroll up
		Setting/increase value
⑧		Next ⁴⁾
		Switch on/select camera ^{2), 3)}
		Confirm selection
		Apply the setting
		Remove ⁴⁾

- ¹⁾ requires a corresponding installation
- ²⁾ requires a corresponding default setting
- ³⁾ with acknowledge ton
- ⁴⁾ associated with image memory

Table 2: Menu operation buttons (Softkeys)

Menu access and page change

The menu consists of 4 to 6 pages depending on the activated special functions and service functions. You access and toggle with the menu slider (10) by swiping your finger horizontally on the touch-sensitive surface (Figure 3).

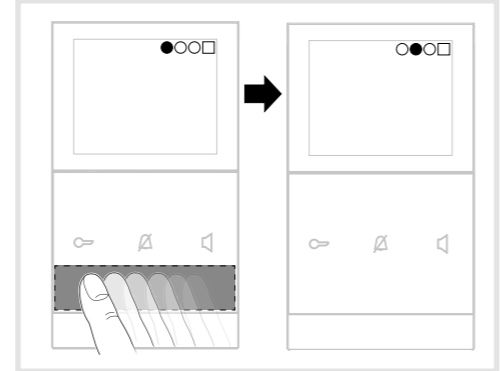

Figure 3: Menu page change

The menu position display (11) shows the current position during the page change.

Menu position display (11)	Menu page
	(start page)
	special functions ⁵⁾
	audio settings
	video settings
	service ⁶⁾ (expanded settings)
	image memory ⁶⁾
	no problem (save/load settings.)

⁵⁾ lockable; only appears if activated

Table 3: Menu pages overview

Application 1: Door call

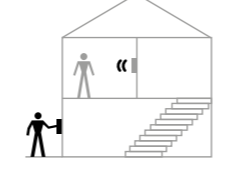

Outside on the door station the assigned call push-button is pressed.

- The indoor station signals a door call:
- The ring tone melody for door call sounds.
 - The LED flashes and the LED lights up.
 - If a camera is installed, the display shows the video image of the calling door station. In the upper left (12) **door** appears with address, e.g. *door 01*.

i The indoor station signals a door call for max. 90 seconds.

Accepting door call and establishing call

- Press speech button .
- A call to the door station is established. The LED lights up permanently. The call connection is established (max. call duration 3 minutes). The symbol appears in the display.
- To end the call, press the speech button again. Call connection and video connection are terminated.

or:

Open door

- Press the button to activate the door release.
- The door of the calling door station is unlocked and can be opened. An ongoing call is terminated automatically approx. 10 seconds after the unlocking.

i Direct door release: In systems with only one door station, the door can be unlocked even without a preceding door call if the door station has been configured accordingly.

Switch on light

The light (e.g. stair light) can be switched on if the associated automatic light is connected to the bus line power supply with relay.

- The display shows the start page.
- Press menu operation button (⑥).
- The light is switched on¹⁾.

¹⁾ requires a corresponding installation

Mute ring tone

The ring tone can be muted if necessary.

The indoor station is in standby mode.

- Press the mute button.
- The LED flashes. The ring tone melody is deactivated.
- Press the mute button once again.
- The LED goes out. The ring tone melody is reactivated.

i The mute function should only be used as briefly as possible in order not to miss any door calls.

Application 2: Storey call

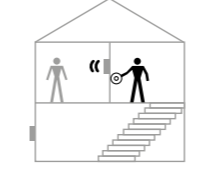

If the storey bell push-button connected to the indoor station is pressed, a storey call is signalled:

- The ring tone melody for the storey call sounds on the indoor station.
- The display shows: **storey door**

i If, in the apartment or building unit (i.e. in the same system branch), up to 2 further, identically addressed indoor stations are installed, these also signal the storey call (storey call forwarding⁶⁾).

⁶⁾ requires the appropriate default setting by the installer (see setting operating modes)

Settings

On the menu pages 3 to 7 (Table 3) individual settings can be made.

Changing settings

- The device is switched on.
- With the menu slider (10) load the required menu page by swiping repeatedly (Table 3).
 - Press / menu operation buttons to select the parameter to be changed and confirm with .
 - With the menu operation buttons / perform the desired settings (stepwise or hold down the button).
 - Press **OK** to apply the settings.

Save/load settings

On the **no problem** menu page press **save settings** to save the individual settings and press **load settings** to reload them at a later time.

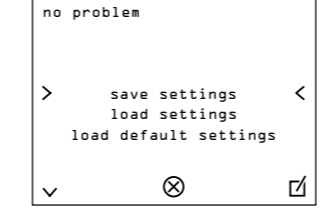

- Select the desired option with / and confirm with .

A prompt appears:

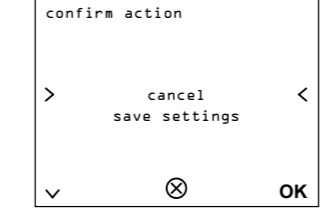

- Press to select the action again and press **OK** to execute it.

or:

- Press **OK** to cancel the action.

i The **load default settings** option restores the state that the device had when handed over by the installer.

Display Settings

Selecting language

The menu language is preset to English at the factory. Under **video settings** it can be changed.

- To switch on the device, press any Softkey (⑥, ⑦ or ⑧), if this has not yet been done.
 - On the menu slider (10) swipe twice from right to left.
- The **video settings** menu page appears.

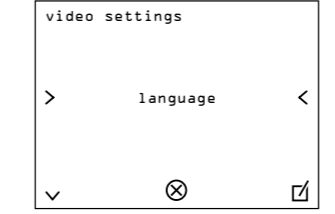

- Confirm **language** with .
- The list of available languages is displayed.
- Press the / menu operation buttons to select the language and confirm with **OK**.

Set display

In idle mode (display switched on, no call) under **video settings** only the language can be selected at first. If a camera picture is shown in the display, then the **contrast**, **brightness** and **colour** of the display can also be adjusted incrementally.

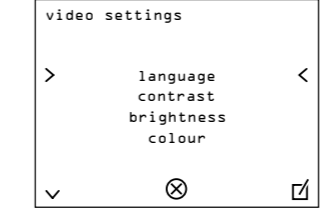

- Press / to select the parameter to be changed and confirm with .
- Press / to perform the desired settings and press **OK** to apply them.

Audio settings

Under **audio settings** the ring tone volume and microphone sensitivity can be adjusted. Here too, ring tone melodies can be selected and assigned to calling stations.

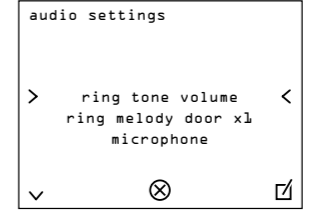

Setting the microphone sensitivity

In hands-free mode, the change-over between listening and speaking takes place automatically depending on the volume. The change-over behaviour can be optimised by adjusting the microphone sensitivity. As a result, the influence of background noise in the area of the indoor station can be reduced.

The adjustment can best be performed during an active call.

- Under **audio settings** select the **microphone** option.
- Adjust the microphone sensitivity incrementally with / .
- Press **OK** to apply the settings.

Activating Push-to-Talk

In **Push-to-Talk** mode the change-over between listening and speaking takes place manually with the speech button.

Speech button	Function	Display
Keep pressed	Speak	
Release	Listen	

- During an active call connection, keep the button pressed for more than 2 seconds.
- For the current call, hands-free mode is changed to Push-to-Talk mode. The symbol appears in the status line (5) of the display.

i To end the call, press the softkey .

Selecting and assigning ring tone melodies

You can choose from 16 different ring tone melodies. Individual ring tone melodies can be assigned for door calls, storey calls and internal calls.

The indoor station creates a *ring melody* entry for each calling station or for the connected storey push-button when an incoming call is received for the first time. The assigned melody can be loaded and changed via this entry under **audio settings**.

- Press / to select the *ring melody* entry (e.g. *ring melody door x1*) and confirm with .
- The melody assigned to the station sounds.
- Listen to other ring tone melodies with / until the melody sounds that you wish to use.
- Press **OK** to assign the ring tone melody.

i Afterwards, another call event can be generated, e.g. storey call, and a separate ring tone melody can be assigned to this according to the same procedure.

Increasing/decreasing ring tone volume

Under **audio settings** the **ring tone volume** can also be adjusted in 3 levels.

Information for electricians

Addressing and pre-settings

The device addressing and setting of the operating modes must already be carried out prior to installation using the rotary switch and DIP-switch on the back of the device (Figure 4).

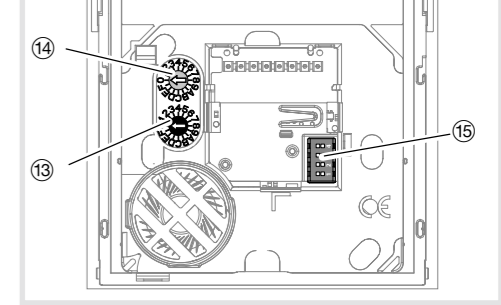

Figure 4: Rear view of the control unit

- ⑬ Address rotary switch (black) for group address
- ⑭ Address rotary switch (blue) for intercom device address
- ⑮ DIP-switch for operating modes

Addressing the device

The indoor station can be addressed quickly and easily using both address rotary switches (13), (14). The address to be set is 2-digit, comprising group address and intercom device address. It must be identical with the address of the associated call push-button on the door station. Figure 5 shows the structure of the address by way of example:

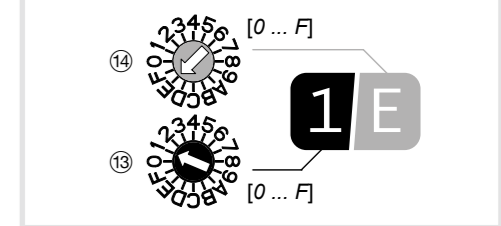

Figure 5: Example address "1/E"

- On the black rotary switch (13) set the group address [0 ... F]
- On the blue rotary switch (14) set the intercom device address [0 ... F].

i A maximum of 3 indoor stations with the identical address setting may be installed for the parallel operation.

- For door stations with automatic call push-button addressing also see operating instructions of the door station. For door stations with push-button interface/expander see operating instructions of the interface.

Setting operating mode

- Set the DIP-switch for operating modes (15) according to Table 4.

Switch	Function (Factory setting = OFF)
OFF	Hands-free mode: automat. Half duplex, switchable to Push-to-Talk via speech button
1 ON	Push-to-Talk: manual half duplex speech mode, set permanently
OFF	Storey call forwarding blocked
2 ON	Storey call forwarding to max. 2 indoor stations with the same address in the same branch
OFF	Menu service available
3 ON	Menu service blocked, is not displayed
OFF	Normal operation, no parallel call to intercom device address 0
4 ON	Parallel call to intercom device address 0 with identical group address

Table 4: DIP-switch settings

Installation and electrical connection

The supporting plate ③ must be mounted on the wall before wiring.

Mounting the supporting plate

A 2-wire bus cable, and if necessary, a connection cable of the storey push-button are laid to the mounting location.

Recommended installation height: 1.5 m.

- Separate supporting element ⑩ on the pre-determined breaking point from the supporting plate.
- For installation on a wall box (Figure 6):
 - Mount the supporting element ⑩ onto wall box so that the smooth surface is pointing straight ahead and the outer cable tie mounts ⑰ are lying on the screw domes of the wall box.
 - Pre-align supporting element with 2 screws.

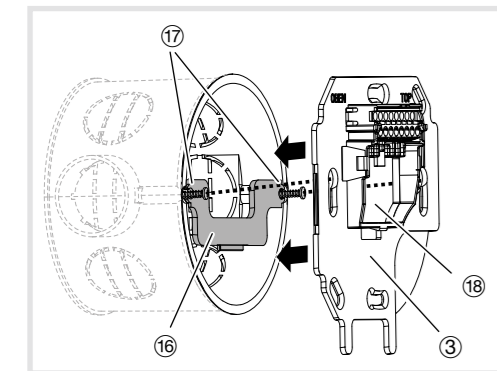

Figure 6: Installation on a wall box

- ⑩ Supporting element
- ⑰ Cable tie mounts
- ⑱ Opening to the cable bushing

For surface-mounting without wall box:

- Mark the fixing holes with supporting plate ③. Observe alignment marks.
- Drill fixing holes and insert dowels.

For both installation modes:

- Run the stripped 2-wire bus cable through the middle opening ⑩ of the supporting plate.
- Also run the connection cable of the associated storey push-button through.
- Mount the supporting plate ③ onto the wall or the wall box with at least 2 screws. Observe alignment marks.

Connect device

Figure 7 shows a schematic view of the connection from the video indoor stations to the bus line power supply:

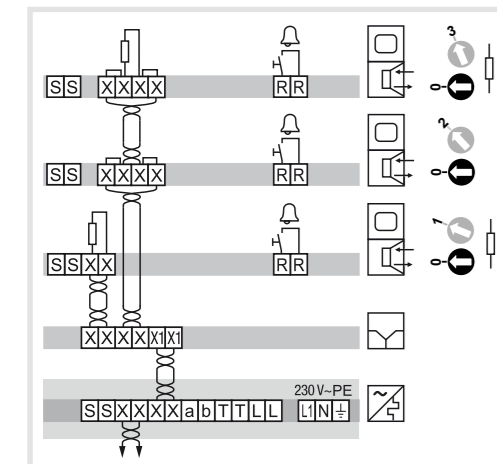

Figure 7: Connection to bus line power supply

- Indoor station VIDEO
- Video distributor 2gang
- Bus line power supply
- Wrapped wire pair for 2-wire devices (recommendation: white/yellow wire pair)

Additional audio and video indoor stations can be connected according to this principle.

For detailed system connection diagrams and information about cables see operating instructions of the bus line power supply.

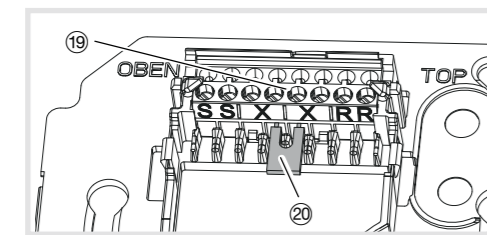

Figure 8: Connection terminal block

- ⑱ Connection terminal block
- ⑳ Terminating resistor/terminator

- Connect the stripped wires of the 2-wire bus cable to the connecting terminals X/X.

Both terminals X/X are each implemented twice (bridged) for incoming and outgoing 2-wire bus cable (Figure 8).

- If the indoor station is not the last intercom device in the branch/line, then remove the terminating resistor/terminator ⑳ from the terminals X/X.

- Connect the associated storey push-button to the connecting terminals R/R.

The terminals S/S are used for connecting the additional infeed, if necessary.

Mounting indoor station (display & operating unit) (Figure 9)

- Mount design frame ② in correct position on the back of the cover.

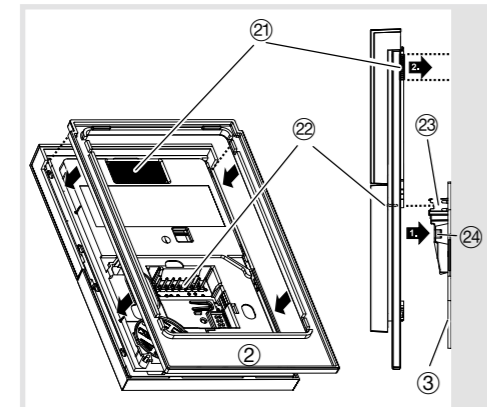

Figure 9: Installation

- ②① Velcro fastening (optional)
- ② Pin header of the operating unit
- ③ Cable connector of the connection terminal block
- ④ Locking hook

- For installation on smooth walls the Velcro fastening ②① may be used. To do this, remove adhesive foil.

When using the Velcro fastening the surface must be clean and free of dust. Do not use on sensitive wallpapers or on badly adhering surfaces.

- Align the indoor station in such way to the supporting plate ③ that the backside pin header ② is pointing to the cable connection of the connection terminal block ③.

- Mount the indoor station onto the supporting plate and carefully press on until the locking hooks ④ interlock.

- When using the Velcro fastening: Press indoor station above onto the wall at the height of the velcro fastening.

Expanded settings

The service menu page provides information about the device address, current DIP switch setting and firmware version. It also enables expanded settings.

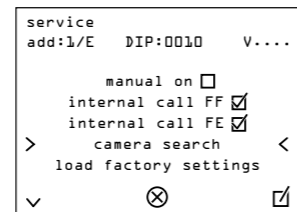

Allowing/preventing manual switching-on of the camera

The video connection to the video door station is established automatically during the door call and terminated again automatically after the end of the call.

With the manual on function it is also possible to enable the camera of the door station that last called to be switched on via the indoor station without a door call.

If the checkmark is set, the camera symbol appears at the bottom right of the start page.

The camera can be switched on manually with the associated Softkey.

If several video door stations or additional cameras are installed in the same line, it is possible to toggle between the camera pictures by pressing repeatedly.

The device is not suitable for video monitoring!

Image memory

The image memory option will be functional when the system is connected to an "Access gate", since all image memory data are stored in this access gate.

When configuring the image capture option in the access gate, the image memory page will appear in the menu of the supporting plate on the first notification message transmitted by the access gate.

After the option was activated, the image memory page will appear in the menu.

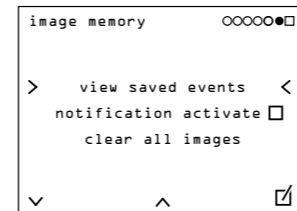

The view saved events page allows to display all the images recorded and stored inside the access gate.

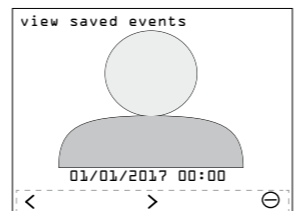

Date and time of the recorded image are displayed on the screen.

Use the keys < / > to scroll the recorded images/videos. To remove an image, use the key ⊖.

The function notification activated allows informing the user that an image queued up to play is recorded, LED lights up until the image is played. This function may be activated/deactivated.

The function remove all images allows the user to remove all the images stored in the access gate. When selecting this function, a request for confirmation is displayed before the full data are removed.

Authorize/prohibit the mute function

The mute function allows you to deactivate or activate the ring tone of call by simply pressing the key (crossed bell symbol). This function may be authorized/prohibited if desirable.

This function may be remotely activated/deactivated via a mobile terminal when the system is connected to an "Access gate".

Searching for cameras

The camera search function starts a search to determine all additional video cameras installed in the line.

- If this function is called, all current door cameras will be deleted from the memory of the indoor station.
- During the next respective door call, the door cameras are then reassigned.

Special functions

After selecting a function (F1 to F8), you can associate it with 8 special functions (see below) available via the "service" page (functions F1 to F8).

Special function	Task	Parameters/information
auto door release 6)	Automatic door release after pressing the call key on the outdoor plate.	Actuation time (time of opening door) 0 = 1s; 1 = 2s; 2 = 3s; ... ; F = 15s
sc autom. release	Automatic door release following storey call (bell push-button connected to the indoor station) via a 2-wire bus relay (e.g. RED114Y)	Relay activation time (time of opening door) 0 = 1s; 1 = 2s; 2 = 3s; ... ; F = 15s
2D-relay	Activation of a 2-wire bus relay, for instance to control lighting.	Relay address 0 to F
Internal call	Allows internal calls between indoor stations having the same group address.	Intercom address of the other indoor station (0 to F). Operates only in its own line and is not transmitted to the other lines via the coupler
Intern. connection	Connection between 2 indoor stations without ring tone. The 2 stations must belong to the same group	Intercom address of the other indoor station (0 to F). No need to activate parallel operation with indoor stations. Operates only in its own line and is not transmitted to the other lines via the coupler
Door release	Allows releasing the door from the indoor station, with no prior call from the outdoor plate.	Group address of the outdoor plate (0 to F). Operates only in its ownline and is not transmitted to the otherlines via the coupler
Video parallel	Makes it possible to display video on an indoor station, while an audio station has taken the call. The 2 stations must belong to the same group.	Intercom address of the other indoor station (0 to F). Operates only in its own line and is not transmitted to the other lines via the coupler
Internal call F	Allows internal calls to indoor stations having address group F.	Intercom address of the other indoor station (0 to F). Operates only in its own line and is not transmitted to the other lines via the coupler

⁷⁾ This function may be remotely activated/deactivated via a mobile terminal when the system is connected to an access gate.

A detailed description of these functions can be found at: <http://www.hager.com>

Configuring a special function

- Select the service page: the 8 special functions are available.

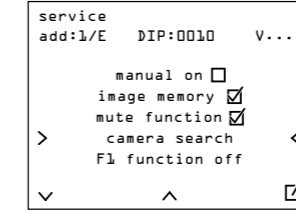

- Use the control keys < / > to select functions F1 to F8, then validate with the key ↵.

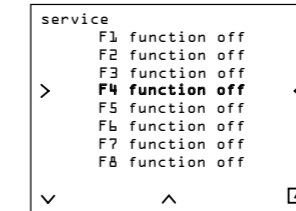

If no function was programmed, the 8 functions are displayed as "F1... F8 function deactivated".

- After selecting a function (e.g. F1), a page F1 function selection displays the list of special functions. Select the special function desired using the keys < / > then validate with key OK.

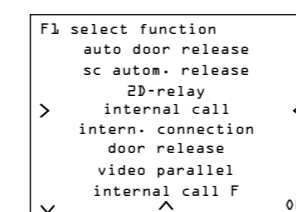
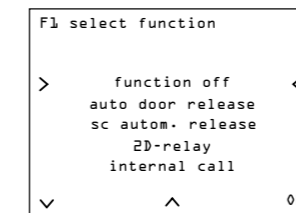

After selecting the special function and the value of its parameter, the special functions page will be displayed in the top menu

Resetting to factory settings

The device software can be reset to factory settings. The DIP-switch configuration remains unchanged.

- Under service menu press < / > to select the load factory settings option and confirm with ↵.

A prompt appears:

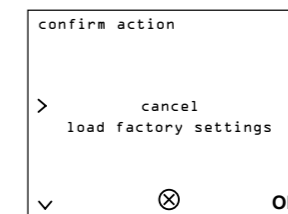

- Press < / > to select load factory settings and reset the software with OK.

or:

- Press OK to cancel the action.

Appendix

Technical data

Supply voltage X/X via bus	22 ... 24 V=
Current consumption (operation)	max. 220 mA
Current consumption (Stand-by)	≈ 12 mA
Sound pressure level ring tone via loudspeaker at a distance of 0.5 m	78 dB(A)
Call volume (hands-free)	max. 65 dB(A)
TFT display size	3.5"
Resolution of graphical display	320 x 240 px
Degree of protection	IP 30
Operating temperature	5 °C ... 50 °C
Connecting terminal for conductor cross-section	max. 0.75 mm²
Dimensions including design frame (W x H x D)	93 x 163.5 x 16 mm
Ring tone volume (signal)	according to EN 50486

Standards

Ring tone volume (signal) according to EN 50486



Correct Disposal of This product (Waste Electrical & Electronic Equipment)

(Applicable in the European Union and other European countries with separate collection systems). This marking shown on the product or its literature indicates that it should not be disposed with other household waste at the end of its working life. To prevent possible harm to the environment or human health from uncontrolled waste disposal, please separate this from other types of wastes and recycle it responsibly to promote the sustainable reuse of material resources. Household users should contact either the retailer where they purchased this product, or their local government office, for details of where and how they can take this item for environmentally safe recycling. Business users should contact their supplier and check the terms and conditions of the purchase contract. This product should not be mixed with other commercial wastes of disposal.