

**Push button 3gang standard
flush-mounted
751633xx**

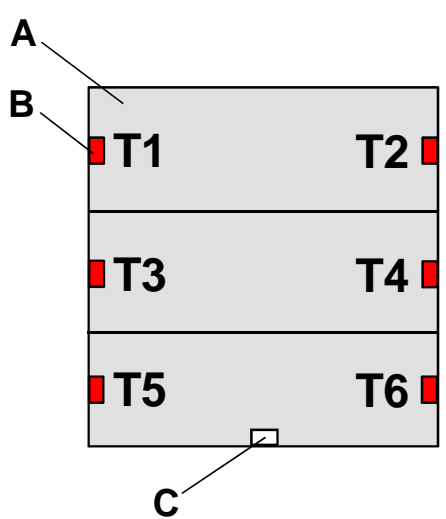

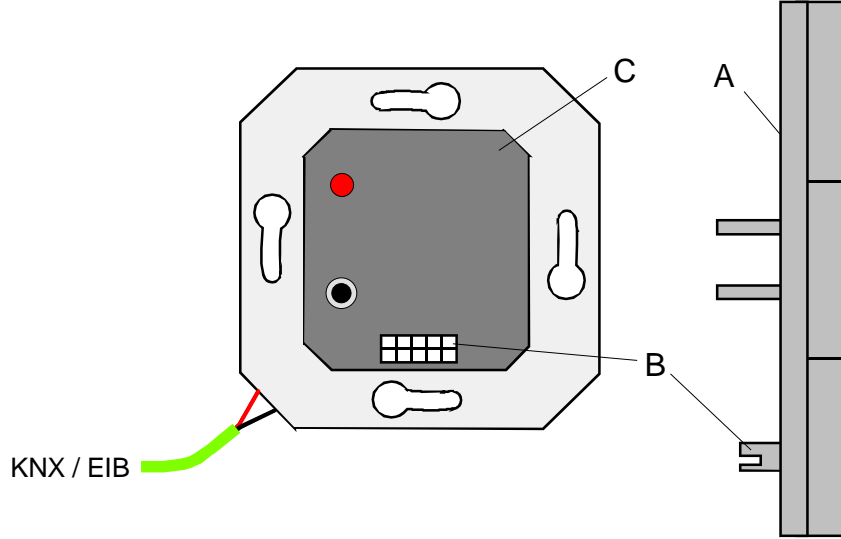

Technical
Documentation



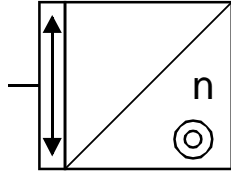



Product name: Push button 3gang standard	
Design: flush-mounted device (uP)	
ETS search path: Push button / Push button 3gang / Push button 3gang standard	
Functional description: The push button 3gang standard is plugged onto a flush-mounted bus coupling unit (BCU) (cf. connection diagram). After a press on the key, the push button sensor will transmit software-dependent telegrams to the KNX / EIB. These may be telegrams for switching, push button operation, dimming or for shutter control. It is also possible to program value transmitter functions such as dimming value transmitter or light-scene extension units. A white operation LED can serve as orientation lighting.	
Layout 	Dimensions Width: 70 mm Height: 55 mm Depth: 13 mm (without PEI)
Controls A: 3 rockers or 6 push buttons (position: left / right) B: 3 x 2 status-LED (red) C: 1 x Operation-LED (white)	
Technical Data	
Type of protection	IP 20
Safety class	III
Mark of approval	KNX / EIB
Ambient temperature:	-5 °C ... +45 °C
Storage / transport temperature	-25 °C ... +70 °C (storage above +45 °C reduces the lifetime)
Mounting position	any
Minimum distances:	none
Type of fastening	plugging onto flush-mounted BCU
KNX / EIB supply	
Voltage	21 – 32 V DC (SELV) via flush-mounted BCU
Power consumption:	typically 150 mW
Connection:	2 x 5 pole pin contact strip
External supply	---

Response to bus voltage failure Bus voltage only:	object values are deleted, LEDs extinguished
Response on return of bus voltage: Bus voltage only:	no reaction
Input:	---
Output:	---
Connection and terminals:	
 <p>The diagram shows a top-down view of the push button assembly. It consists of an octagonal outer housing (C) with three mounting slots. Inside is a dark grey central panel (A) with a red LED indicator and a circular button. Below the panel is a physical external interface (B) with a grid of terminals. A green and red cable labeled 'KNX / EIB' is connected to the terminals. To the right, a side view shows the assembly mounted on a vertical rail, with labels A, B, and C pointing to the corresponding parts.</p>	
A: push button standard 3gang B: physical external interface (PEI) C: bus coupling unit (BCU)	
Hardware remarks	
• ---	









Software description			
ETS search path		ETS symbol	
Push button / Push button 3gang / Push button 3gang standard			
PEI type	04 _{Hex}	4 _{Dez}	2 inputs / 2 outputs
Applications:			
No.	Summarized description:	Name:	Version:
1	Switching, status	Switching, status 107901	0.1
2	Switching, acknowledge	Switching, acknowledgement 107A01	0.1
3	Dimming	Dimming 107C01	0.1
4	Shutter	Shutter 107B01	0.1
5	Value transmitter	Value transmitter 107D01	0.1

Application:		1. Switching, status 107901			
Executable from mask version:		1.0			
Number of addresses (max):		13	dynamic table handling:		Yes <input checked="" type="checkbox"/> No <input type="checkbox"/>
Number of assignments (max):		13	maximum length of table:		26
Communication objects:		3			
Object	Function	Name	Type	Flag	
 0	Switching	Push buttons 1 and 2	1 bit	C, W, T	
 1	Switching	Push buttons 3 and 4	1 bit	C, W, T	
 2	Switching	Push buttons 5 and 6	1 bit	C, W, T	
Object description					
Objects:					
 0 - 2	Switching: 1-bit object for the transmission of switching telegrams (ON, OFF)				
Scope of functions					
<ul style="list-style-type: none"> • Function of operating LED and of status LED parameterizable • Command on key press parameterizable (ON, OFF) 					

Parameters		
Description:	Values:	Remarks:
 General		
Function of the operating LED	OFF ON	Defines the status of the operation LED.
Function of the status LEDs	OFF ON	Defines the status of the status LED.
Command at operation the left push buttons	OFF ON	Defines the command transmitted on pressing the left push buttons (key 1/3/5).
Command at operation the right push buttons	OFF ON	Defines the command transmitted on pressing the right push buttons (key 2/4/6).
Software remarks		
<ul style="list-style-type: none"> • The status LED indicates the current status of the switching object. If a key is pressed (e.g. ON) and if the push button sensor does <u>not</u> get a positive acknowledgement (IACK) from an addressed actuator, the object status is updated, but the corresponding status LED is <u>not</u> lit up. 		

Application:		2. Switching, acknowledge 107A01		
Executable from mask version:		1.0		
Number of addresses (max):		10	dynamic table handling:	Yes <input checked="" type="checkbox"/> No <input type="checkbox"/>
Number of assignments (max):		10	maximum length of table:	20
Communication objects:		3		
Object	Function	Name	Type	Flag
 0	Switching	Push buttons 1 and 2	1 bit	C, W, T
 1	Switching	Push buttons 3 and 4	1 bit	C, W, T
 2	Switching	Push buttons 5 and 6	1 bit	C, W, T
Object description				
Objects:				
 0 – 2	Switching:	1-bit object for the transmission of switching telegrams (ON, OFF)		
Scope of functions				
<ul style="list-style-type: none"> • Function of operating LED and of status LED parameterizable • Command on key press parameterizable (ON, OFF) 				

Parameters		
Description:	Values:	Remarks:
 General		
Function of the operating LED	OFF ON	Defines the status of the operation LED.
Function of the status LEDs	OFF ON	Defines the status of the status LED.
Light duration of the status LEDs (push button 1 ... 6)	0.75 s 4.5 s 1.5 s 6.0 s 2.25 s 10 s 3.0 s 15 s	Defines the time during which the status LED is on in case of a positive acknowledgement of receipt from an addressed actuator.
Command at operation the left push buttons	OFF ON	Defines the command transmitted on pressing the left push buttons (key 1/3/5).
Command at operation the right push buttons	OFF ON	Defines the command transmitted on pressing the right push buttons (key 2/4/6).
Software remarks		
<ul style="list-style-type: none"> • The status LED is on for a parameterizable time in case of a positive acknowledgement from an addressed actuator. If a key is pressed (e.g. ON) and if the push button sensor does <u>not</u> get a positive acknowledgement (IACK) from an addressed actuator, the object status is updated, but the corresponding status LED is <u>not</u> lit up. 		

Application:		3. Dimming 107C01		
Executable from mask version:		1.0		
Number of addresses (max):		12	dynamic table handling:	Yes <input checked="" type="checkbox"/> No <input type="checkbox"/>
Number of assignments (max):		12	maximum length of table:	24
Communication objects:		6		
Object	Function	Name	Type	Flag
 0	Switching	Push buttons 1 and 2	1 bit	C, W, T
 1	Switching	Push buttons 3 and 4	1 bit	C, W, T
 2	Switching	Push buttons 5 and 6	1 bit	C, W, T
 4	Dimming	Push buttons 1 and 2	4 bit	C, T
 5	Dimming	Push buttons 3 and 4	4 bit	C, T
 6	Dimming	Push buttons 5 and 6	4 bit	C, T
Object description				
Objects:				
 0 - 2	Switching:	1-bit object for the transmission of switching telegrams (ON, OFF)		
 4 - 6	Dimming:	4-bit object for change of relative brightness between 0 and 100 %		
Scope of functions				
<ul style="list-style-type: none"> Function of operating LED and of status LED parameterizable 				

Parameters		
Description:	Values:	Remarks:
 General		
Function of the operating LED	OFF ON	Defines the status of the operating LED.
Function of the status LEDs	OFF ON	Defines the status of the status LED.
Software remarks		
<ul style="list-style-type: none"> The status LED indicates the current status of the switching object. If a key is pressed (e.g. ON) and if the push button sensor does <u>not</u> get a positive acknowledgement (IACK) from an addressed actuator, the object status is updated and the corresponding status LED is lit up. 		

**Push button 3gang standard
flush-mounted
751633xx**





Technical
Documentation





Application:		4. Shutter 107B01			
Executable from mask version:		1.0			
Number of addresses (max):		12	dynamic table handling:		Yes <input checked="" type="checkbox"/> No <input type="checkbox"/>
Number of assignments (max):		12	maximum length of table:		24
Communication objects:		6			
Object	Function	Name	Type	Flag	
0	Step operation	Push buttons 1 and 2	1 bit	C, W, T	
1	Step operation	Push buttons 3 and 4	1 bit	C, W, T	
2	Step operation	Push buttons 5 and 6	1 bit	C, W, T	
4	Move operation	Push buttons 1 and 2	1 bit	C, W, T	
5	Move operation	Push buttons 3 and 4	1 bit	C, W, T	
6	Move operation	Push buttons 5 and 6	1 bit	C, W, T	
Object description					
Objects:					
0 - 2	Step operation:	1-bit object for step (short-time) operation of a shutter			
4 - 6	Move operation:	1-bit object for move (long-time) operation of a shutter			
Important: Unused communication objects must be projected with dummy group addresses. Otherwise risk of malfunctions.					
Scope of functions					
<ul style="list-style-type: none"> • Function of operation LED parameterizable • Time between two telegrams (time between STEP and MOVE) presettable 					

Parameters		
Description:	Values:	Remarks:
General		
Function of the operating LED	OFF ON	Defines the status of the operating LED.
Push buttons 1 and 2		
Time between two telegrams, base	130 ms (fixed)	Defines the time base between two telegrams. (time between STEP and MOVE) Time = base • factor
Time between two telegrams, factor (3...127)	3 ... 127; 3	Defines the time factor between two telegrams. (time between STEP and MOVE) Time = base • factor Presetting: 130 ms • 3 = 390 ms
Push buttons 3 and 4		
See push buttons 1 and 2		
Push buttons 5 and 6		
See push buttons 1 and 2		

Application:		5. Value transmitter 107D01		
Executable from mask version:		1.0		
Number of addresses (max):		1	dynamic table handling:	Yes <input checked="" type="checkbox"/> No <input type="checkbox"/>
Number of assignments (max):		1	maximum length of table:	2
Communication objects:		1		
Object	Function	Name	Type	Flag
<input type="checkbox"/> 0	Value / light-scene	Rockers	1 byte	C, T
Object description				
Objects:				
<input type="checkbox"/> 0	Value / light-scene	1-byte object for transmitting value telegrams of for recalling light-scenes		
Scope of functions				
<ul style="list-style-type: none"> • Function of operating LED and of status LED parameterizable • Mode of operation (value transmitter / light-scene recall with / without storage function) freely selectable • Values (1 byte) or light-scene numbers (1...8) for all keys individually parameterizable 				

Parameters		
Description:	Values:	Remarks:
 General		
Function of the operating LED	OFF ON	Defines the status of the operation LED.
Function of the status LED	OFF ON	Defines the status of the status LED.
Operating mode	Value transmitter Recall light-scene without memory function Recall light-scene with memory function	Defines the function of the push button sensor.
 Push buttons 1 and 2 with "Operating mode = value transmitter"		
Left push button value (0...255)	0 ... 255; 1	Defines the value transmitted when the left push button is pressed.
Right push button value (0...255)	0 ... 255; 4	Defines the value transmitted when the right push button is pressed.
 Push buttons 1 and 2 with "Operating mode = recall light-scene with / without memory function"		
Left push button Light scene (1...8)	1 ... 8; 1	Defines the value transmitted when the left push button is pressed.
Right push button Light scene (1...8)	1 ... 8; 4	Defines the value transmitted when the right push button is pressed.
 Push buttons 3 and 4 with "Operating mode = value transmitter"		
Left push button value (0...255)	0 ... 255; 1	Defines the value transmitted when the left push button is pressed.

Right push button value (0...255)	0 ... 255; 4	Defines the value transmitted when the right push button is pressed.
 Push buttons 3 and 4 with "Operating mode = recall light-scene with / without memory function"		
Left push button Light scene (1...8)	1 ... 8; 1	Defines the value transmitted when the left push button is pressed.
Right push button Light scene (1...8)	1 ... 8; 4	Defines the value transmitted when the right push button is pressed.
 Push buttons 5 and 6 with "Operating mode = value transmitter"		
Left push button value (0...255)	0 ... 255; 2	Defines the value transmitted when the left push button is pressed.
Right push button value (0...255)	0 ... 255; 5	Defines the value transmitted when the right push button is pressed.
 Push buttons 5 and 6 with "Operating mode = recall light-scene with / without memory function"		
Left push button Light scene (1...8)	1 ... 8; 2	Defines the value transmitted when the left push button is pressed.
Right push button Light scene (1...8)	1 ... 8; 5	Defines the value transmitted when the right push button is pressed.

Software remarks

- Light-scene extension unit:

When a key is pressed for more than 1 s, the parameterized light-scene is recalled and the pertaining status LED switched on for about 1 s. If a key is pressed during a light-scene recall with storage function for more than 5 s, a storage telegram corresponding to the parameterized light-scene will be transmitted and the status LED is lit up for 4 s. Pressing a key with storage function for a time between 1 s and 5 s is without effect.

The status LED lights up after a key-press only in conjunction with a positive acknowledgement (IACK) from an addressed actuator.

- Value transmitter:

The status LED lights up after a key-press only in conjunction with a positive acknowledgement (IACK) from an addressed actuator.