







	<h2>application software</h2>	
-----------------------------------------------------------------------------------	-------------------------------	-------------------------------------------------------------------------------------

<ul style="list-style-type: none"> ▲ Manufacturers ▲ Hager Electro ▲ Heating, Air Conditioning <li style="background-color: #e0ffe0; padding: 2px;">Heating actuators

Heating actuator

Electrical/Mechanical characteristics: See product user manual

	Product reference	Product designation	Application software ref	TP device  Radio device 
	TYMS646T	Heating actuator 6 channels KNX 24/230V	STYMS646T 1.1.x Version	
	TYMS646R	Heating actuator 6 channels KNX, with regulation, 24/230V	STYMS646R 1.1.x Version	

Content

1	General	5
1.1	General information about this application description	5
1.2	ETS Programming software	5
1.3	Connexion KNX secure	5
2	General Description	8
2.1	Installation of the device	8
2.1.1	Overview presentation	8
2.1.2	Description of the device	9
2.1.3	Physical addressing	9
2.1.4	Connection	10
2.1.5	LED meaning	11
2.2	Function modules of the application	12
2.2.1	General	12
2.2.2	Outputs	14
2.2.3	Thermostat	16
3	Parameters	21
3.1	Definition of the general parameters	21
3.1.1	General	21
3.1.1.1	Output configuration	21
3.1.1.2	Activation of manual mode	23
3.1.1.3	Activation of the Status indication	23
3.1.1.4	Activation of the logic blocks	23
3.1.1.5	Summer/winter mode	24
3.1.1.6	Service mode	26
3.1.1.7	Diagnosis	28
3.1.1.8	LED display	30
3.1.1.9	Date and time format	30
3.1.1.10	Restore ETS-Parameters	31
3.1.1.11	Heating activation	32
3.1.1.12	Objects emission delay at bus return	32
3.1.2	Valve / Pumps	33
3.1.2.1	Short circuit/Overload status indication	34
3.1.2.2	Heat requirement	36
3.1.2.3	Largest command value	39
3.1.2.4	Pump control	41
3.1.2.5	Pump protection	44
3.1.3	Manual mode	47
3.1.3.1	Duration of manual mode activation	48
3.1.3.2	Deactivation of manual mode	48
3.1.3.3	Status indication manual mode	49
3.1.4	Logic block	50
3.1.4.1	Configuration	52
3.1.4.2	Logic block authorization	53
3.1.4.3	Logic result	54
3.1.5	Thermostats assignment	56
3.1.6	Status valve outputs	57
3.2	Output functionalities	60
3.2.1	Overall parameters	60
3.2.2	General	61
3.2.2.1	Valve	62
3.2.2.2	Behavior at reset	62
3.2.2.3	Hours counter	63
3.2.2.4	Valve protection	64
3.2.2.5	Lock-up	64
3.2.3	Function selection	65

3.2.4 Control/Status/Operating mode	67
3.2.4.1 General	67
3.2.4.2 Command value monitoring.....	70
3.2.4.3 Command value limitation.....	70
3.2.4.4 Emergency mode.....	72
3.2.4.5 Priority position	73
3.2.4.6 Short circuit/Overload status indication.....	75
3.2.5 Valve protection	76
3.2.6 Hours counter	79
3.2.7 Lock-up	82
3.3 Thermostat functions	86
3.3.1 Thermostats naming	86
3.3.2 General	87
3.3.2.1 Operation	88
3.3.2.2 Thermostat deactivation.....	91
3.3.2.3 Valve protection	93
3.3.2.4 Presence detection	97
3.3.3 Function selection.....	97
3.3.4 Basic heating	101
3.3.5 Additional heating	106
3.3.6 Basic cooling.....	109
3.3.7 Additional cooling.....	112
3.3.8 Ventilation	116
3.3.9 Temperature measurement	120
3.3.10 Emission	124
3.3.11 Setpoints.....	127
3.3.12 Scene.....	133
3.3.13 Priority.....	135
3.3.14 Timer.....	139
3.3.15 Preset.....	141
3.3.16 Lock-up	145
4 Communication objects.....	150
4.1 Communication objects General	150
4.1.1 Summer/winter mode.....	151
4.1.2 Short circuit/Overload status indication.....	152
4.1.3 Heat requirement	153
4.1.4 Largest command value.....	154
4.1.5 Service mode.....	155
4.1.6 Pump control.....	156
4.1.7 Pump protection.....	157
4.1.8 Heating activation	160
4.1.9 Logic block.....	160
4.1.10 Date and time format	162
4.1.11 Manual mode	164
4.1.12 Behaviour of the device	165
4.1.13 Diagnosis	165
4.2 Output communication objects.....	166
4.2.1 Switching.....	167
4.2.2 Status indication.....	168
4.2.3 Priority.....	169
4.2.4 Hours counter	171
4.2.5 Valve protection	173

4.3 Communications objects per thermostat.....	177
4.3.1 Operating mode	180
4.3.2 Priority	183
4.3.3 Scene	185
4.3.4 Status indication.....	185
4.3.5 Controls.....	188
4.3.6 Room temperature	191
4.3.7 Ventilation	194
4.3.8 Setpoints	198
4.3.9 Setpoint status indication	203
4.3.10 Presence.....	208
4.3.11 Thermostat deactivation.....	208
4.3.12 Timer.....	211
4.3.13 Preset.....	212
4.3.14 Lock-up	213
4.3.15 Valve protection	215
5 Appendix	219
5.1 Specifications.....	219
5.2 Table of logical operations	220
5.3 Characteristics	220

1 General

1.1 General information about this application description

This document describes the operation and parameterisation of KNX devices with the aid of the Engineering Tool Software ETS.

The devices are parameterised by the ETS and the required settings for operation are made during the first installation.

1.2 ETS Programming software

The application programmes are compatible with ETS5 or ETS6 and are always available in their latest version on our Internet website.

ETS Version	File extension of compatible products	File extension of compatible projects
ETS 5 (v 5.0.6 or more)	*.knxprod	*.knxproj
ETS 6 (v 6.0.0 or more)	*.knxprod	*.knxproj

- ETS Application designation

Application	Product designation	Application designation
STYMS646T v1.0	TYMS646T	Heating actuator 6 channels KNX 24/230V
STYMS646R v1.0	TYMS646R	Heating actuator 6 channels KNX, with regulation, 24/230V

1.3 Connexion KNX secure

KNX Secure devices are able to encrypt and decrypt telegrams, thus adding an extra level of security to a KNX installation. This level of security can be used both during the commissioning of KNX installations as for KNX installations at runtime.

There are two types of encryption:

- KNX IP Secure : Telegrams are entirely encrypted and applied only to the KNX IP medium. This encryption must be used for KNX installations using an external IP network such as the Internet.
- KNX Data Secure : Telegrams are partly encrypted and applied to any KNX communication medium. This encryption can be used for the KNX IP medium, but only for the part of the KNX installation that is not exposed to an external IP network.

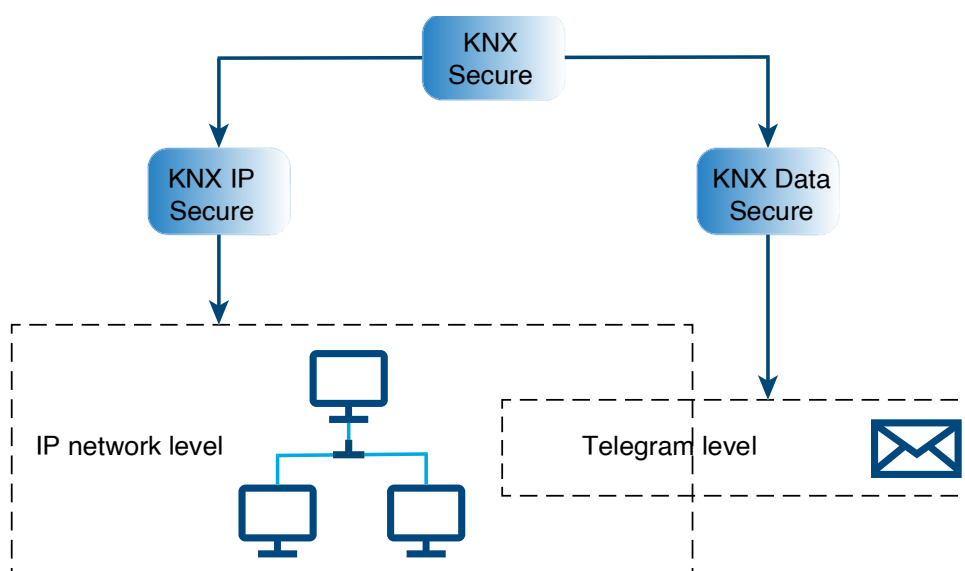

The device is KNX Data Secure capable and can be configured in the ETS project. A device certificate, which is attached to the front to the device, is required for safe commissioning. During mounting, it is recommended to remove the certificate from the device and to store it securely.

Note : It is also possible to commission the device without KNX Data-Secure. In this case, the device is not secured and behaves like other KNX devices.

Note : During the configuration of products in Secure mode, if one of the products mentioned below is installed, it is recommended to replace it by its Secure version:

- Replace the reference TYF120 (KNX/IP Interface) with the reference TYFS120
- Replace the reference TH101 (USB modular data interface) with the reference TYFS122

Commissioning of the KNX Secure mode

The device is mounted and connected ready for use.

1. Activate the secure commissioning mode in ETS.
2. Enter or scan the device certificate to add it to the project in ETS.

Note : To scan the QR code, a high-resolution camera must be used.

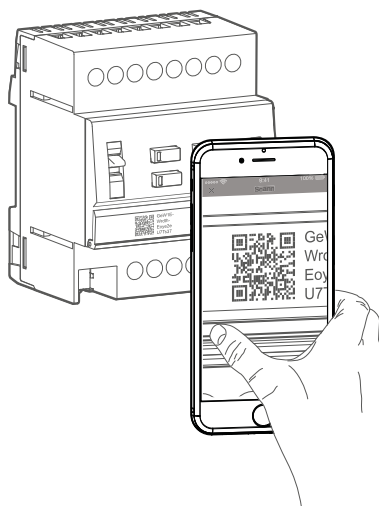

3. Record all passwords and keep them in a safe place.
4. Remove the certificate from the device (QR code) and keep it in a safe place with the passwords.

Master-Reset

The master reset restores the basic device setting.

The reset allows :

- deleting the encryption key
- deleting of the BCU password
- application of the default settings
- the application of a default individual address (15.15.255).

The device must then be recommissioned with the ETS. The manual mode is possible.

In case of Secure mode, a reinitialization deactivates the security of the device. It can then be used again with the device certificate.

How do I perform a Master Reset?

1. Switch off the device by removing the bus connection or disconnecting the power supply to the system
2. Press and hold the lighted push button
3. Switch on the device again by connecting the bus connection or by switching on the power supply to the system

The address LED lights up. After 5 seconds the LED flashes.

4. Release the address button

The address LED lights up permanently while the master reset is in progress.
After several seconds, the LED lights off, indicating that the reset is complete. The device restarts.

Updating the firmware

The device can be updated. Firmware updates can be easily performed with the Hager ETS App. This application is free of charge and can be used on site or remotely.

How to update?

1. Login to **my.knx.org**
2. Create a new account or login with your existing account
3. Search for the **Service Hager** application
4. Add to basket
5. Go to the basket and click on Order
6. Select billing and shipping addresses
7. Click on Go to Payment
8. Confirm payment (free)

The application is now available in your account.

9. Download the application and the licence to update.

In the ETS project :

10. Start the application from the **Apps** tab
11. Select the device to be updated
12. Select the latest available firmware version.
13. Load the device with the firmware
14. After loading is complete, activate the proprietary firmware.

The device will update and restart.

2 General Description

2.1 Installation of the device

2.1.1 Overview presentation

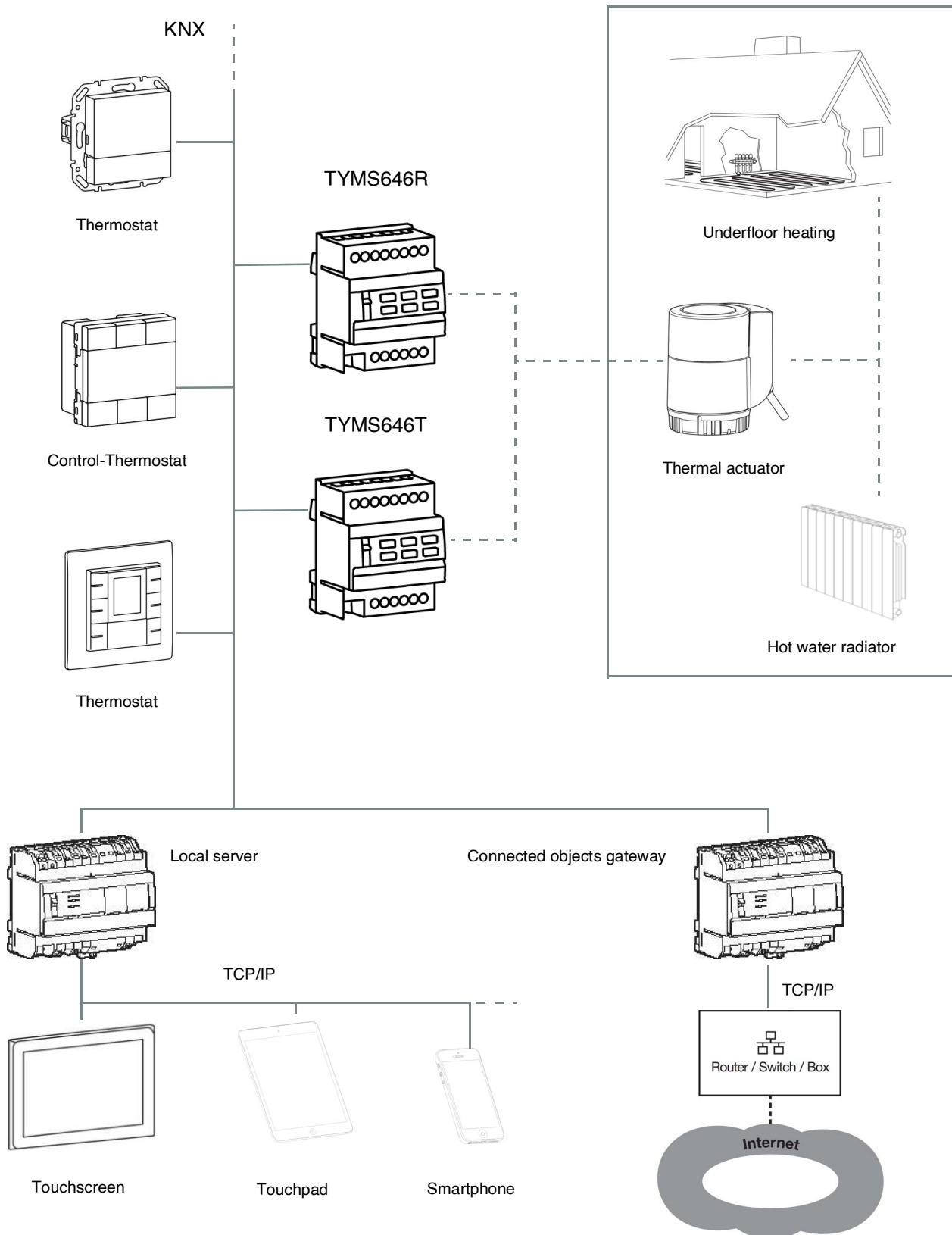

2.1.2 Description of the device

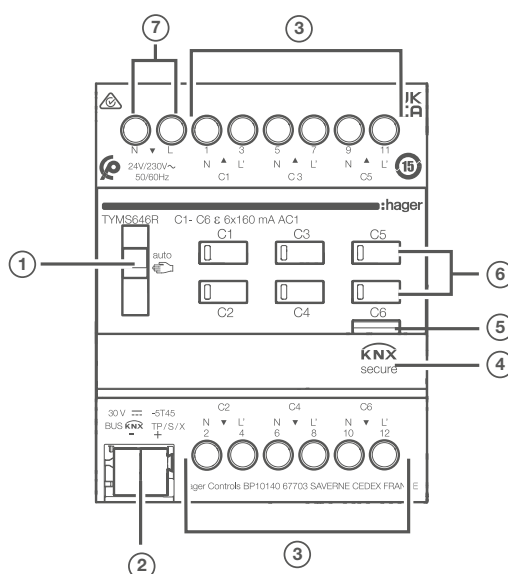

- ① Auto/Manu change-over switch (auto/ 1)
- ② KNX bus connection terminal
- ③ Connection of the thermal valve drives
 - Top group: Outputs C1 + C3 + C5
 - Bottom group: Outputs C2 + C4 + C6
- ④ Labelling field
- ⑤ Illuminated programming button
- ⑥ Operation button for manual operation with status LED
- ⑦ Power supply connection (N, L)

2.1.3 Physical addressing

In order to perform the physical addressing or to check whether or not the bus is connected, press the lighted push button (5) on the right-hand side above the identification plates on the front of the device.

Light on = bus connected and ready for physical addressing.

Programming mode is activated, until the physical address is transferred from ETS. Pressing the button again, exits programming mode. Physical addressing can be carried out in automatic or manual mode.

2.1.4 Connection



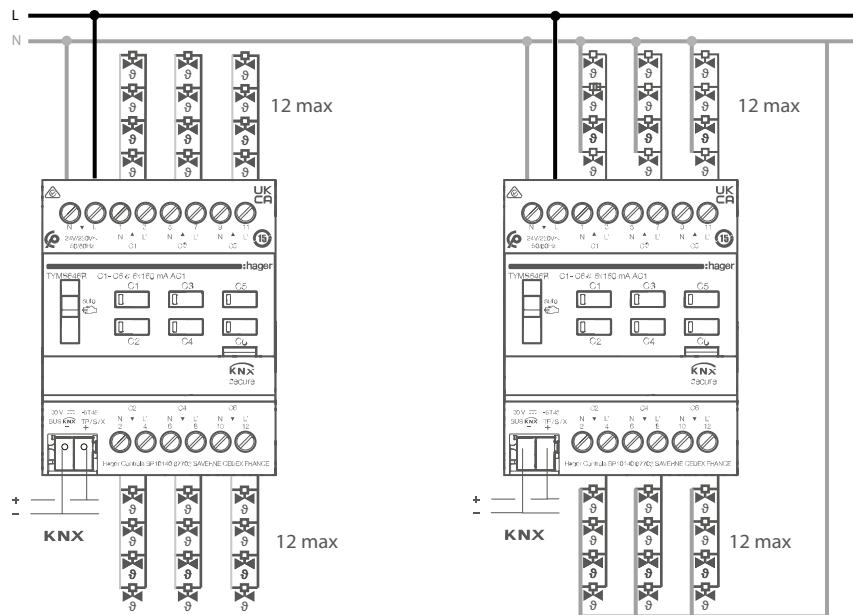



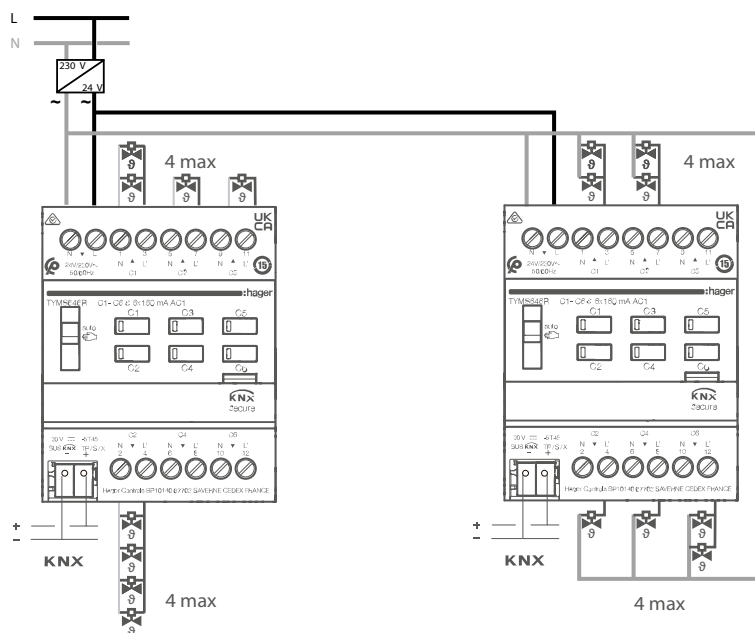













- Valves equipped with thermal actuators with 230 V ~ power supply



- Valves equipped with thermal actuators with 24 V ~ power supply



2.1.5 LED meaning

Cx Red		 OK
		 ⚠
Cx Blue		 OK
		 ⚠
Cx Orange		 Short circuit detection running
		 Short circuit detected
Cx White		 Overload detected, load shedding running
C1 → C6 Orange		 30 V DC  230 V AC
C1 → C6 Green		 50 %
		 100 %

2.2 Function modules of the application

2.2.1 General

The applications configure the general functions of the devices. The following functions apply to the entire device:

■ Manual mode

Manual mode allows the device to be disconnected from the bus. In this mode, each output can be priority controlled locally.

This command has the highest priority. No other command is considered when manual mode is active. Only after ending manual mode are other types of control again permitted. The duration of the manual control can be configured. Manual mode can be locked-up via the KNX bus.

■ Status indication

The behaviour of the status indication of each switching channel can be configured for the entire device. The Status indication function transmits the status of each valve output on the KNX bus.

■ Logic block

The Logic function is used to control an output depending on the result of a logic operation. This command has the lowest priority. The result of the function can be output on the KNX bus and can directly control one or more outputs. There are 2 logic blocks per device with up to 4 inputs available.

■ Diagnosis

The Device diagnosis function allows notifications about the operating state of the device to be sent via the KNX bus. This information is sent periodically and/or on status change.

■ Service mode

For installation or maintenance reasons, it is possible to block the outputs in a predefined status. If the service mode is active, the outputs in question are in completely closed or open position, thus blocking any other control.

■ Pump control

This function is used for activation and deactivation of the heating or cooling circulation pump by the KNX bus. To save energy, the pump is only activated when the energy demand is sufficiently high.

■ Pump protection

A pump may jam if it is not activated for too long a time. To avoid this, the product incorporates a pump protection function. If the control has not been sent for a certain period of time, it will be automatically activated.

■ Heat requirement

The product constantly assesses the output control values. Depending on the energy need, the product can be used to activate or deactivate a boiler or burner.

■ Summer/winter mode

The valve management functions must know if the system is in winter or summer mode. This information is required to apply the correct values to the valve output according to the time of year.

Communication objects



2.2.2 Outputs

The applications allow individual configuration of the device outputs.

The most important functions are:

■ Valve control

The product has 6 independent outputs. These outputs are used to control valves fitted with thermal actuators supplied with 24 V ~ or 230 V ~ to control heating or air conditioning systems using water distribution circuits. The default status of the valve is configurable for each output (normally open or normally closed).

■ Switching PI-control

For each of these outputs, the product receives the heating rate to be applied from one or more thermostats. This control can be in 1 bit or 1 byte format. If the control is sent in 1 byte format, the outputs are controlled by pulse-width modulation (PWM). The cycle time is configurable for each output.

■ Valve protection

A valve can jam if it is not activated for too long a time. To avoid this, the product incorporates a valve protection function. If the output has not been activated for a certain length of time, whatever the current mode, it will be automatically activated.

■ Hours counter

This function is used to count the operating time of an output. The counter setpoint can be programmed and altered via an object.

■ Lock-up

The Lock-up function is used to lock the output in a predefined state.

Priority: Manual mode > Priority > Lock-up > Basic function.

The Lock-up prevents actuation until an unlock command has been received. The Lock-up duration can be set.

■ Priority

The Priority function is used to force the output into a defined state. Priority is activated through objects in 1 or 2 bit format.

Priority: Manual mode > Priority > Lock-up > Basic function.

Only a Priority OFF command authorizes the output for control.

Each valve output can be locked in forced position via the bus. Different parameter values can be configured for the summer and winter mode.

■ Short circuit / Overload

Each output has a limited power capacity. They are protected against potential overloads or short circuits. If a failure appears, notification is automatically sent on the KNX bus.

Communication objects

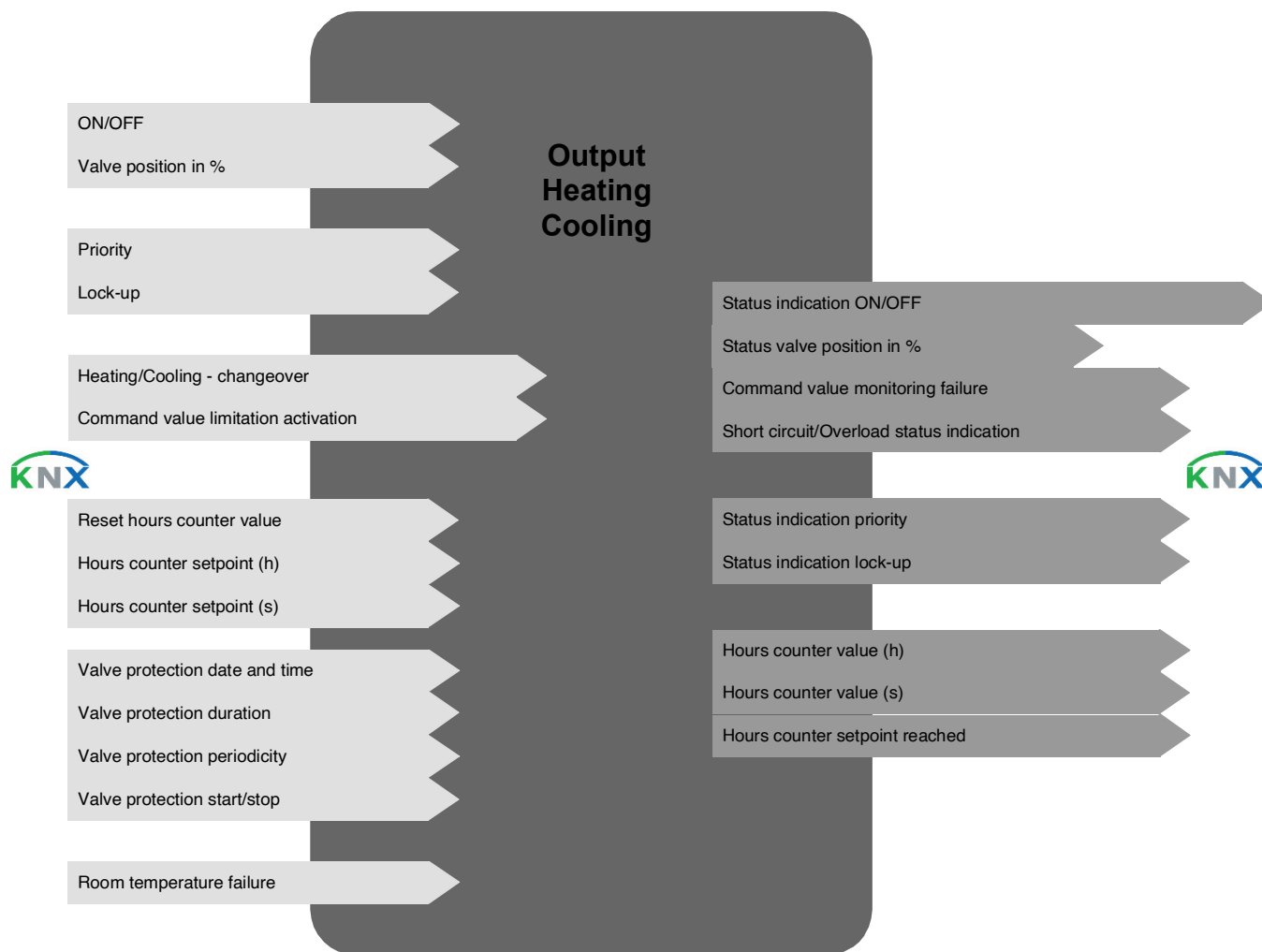

Organisation of control modes

The different types of controls for output management have differing levels of priority. The list below gives the types of controls with their priority level.

Types of controls	Priority level
Valve protection	1
Priority	2
Lock-up	3
Valve control	4

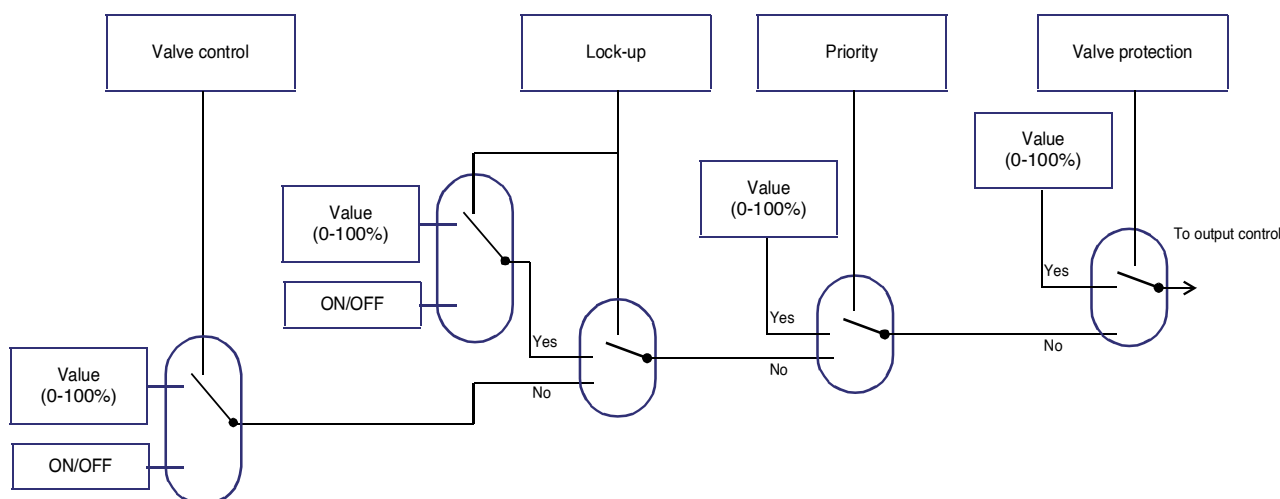

2.2.3 Thermostat

The applications are used to configure each regulator individually. The most important functions are:

■ Room temperature regulation for the heating and cooling systems

The Regulation function is used to control the following installations:

- Heating.
- Cooling.
- Heating / cooling.
- Basic and additional heating.
- Basic and additional cooling.
- Heating / basic and additional cooling.

The product has 12 independent room thermostats.

The switch between heating and cooling can be automatic or manual.

Regulation is based on measurement of the room temperature. This temperature is compared to the setpoint defined by the user.

The types of regulation available are as follows:

- Switching PI-control (PWM)
- Continuous PI-control
- Switching 2-point control

■ Setpoint selection

The thermostat can operate in the following modes:

- Auto.
- Comfort.
- Night setpoint.
- Standby.
- Heat protection / Frost protection.

The operating mode can be selected by push-button, priority, override, timer, clock or activation of a scene.

A temperature setpoint is linked to each operating mode.

■ Timer

The Timer function is used to select a heating or cooling setpoint for a configurable duration. The timer may be interrupted before expiry of the delay time. The timer duration can be modified via the bus KNX.

When the timing function expires, return to the previous operating mode.

■ Priority

The Priority function is used to force the thermostat with a defined heating or cooling setpoint.

Priority is activated through objects in 1 or 2 bit format.

Priority: Manual mode > Priority > Lock-up > Basic function.

Only a Priority OFF command authorizes the output for control.

The setpoints used for thermostat priority are Frost protection / Heat protection and Comfort.

■ Automatic control

The Automatic control function is used to control a thermostat in parallel to the Setpoint selection function. The functions have the same level of priority. The last control received will act on the thermostat status.

An additional command object is used to activate or deactivate the Automatic control.

■ Scene

The Scene function is used to switch groups of outputs into a configurable predefined state. A scene is activated by receipt of a 1-byte command. Each thermostat can be integrated into 64 different scenes.

When the scene is activated, the thermostat can switch to one of the following modes:

- Auto.
- Comfort.
- Standby.
- Night setpoint.
- Frost protection / Heat protection.

■ Preset

The Preset function is used to configure a set of thermostats with a defined heating or cooling setpoint. The Preset function is activated via an object in 1-bit format. Each thermostat can be controlled by 2 Preset objects.

■ Lock-up

The Lock-up function is used to lock the thermostat with a defined heating or cooling setpoint.

Priority: Manual mode > Priority > Lock-up > Basic function.

The Lock-up prevents actuation until an unlock command has been received. The Lock-up duration can be set.

■ Heat protection / Frost protection

The Protection function is used to protect a building against risks linked to frost in winter or temperatures which are too high in summer. The Frost protection function is active in heating mode and the Heat protection function is active in cooling mode.

■ Fan speed

The Fan speed function is used to configure the ventilation speed of a fancoil. The speed can be set according to 6 levels: increasing speed from 1 to 6.

■ Valve protection function

A valve can jam if it is not activated for too long a time. To avoid this, the product incorporates a valve protection function. If the output has not been activated for a certain length of time, whatever the current mode, it will be automatically activated.

If the valve output does not have this mechanism, the thermostat must implement this function.

■ Status indication

The following information can be sent on the bus:

- Current mode (Comfort, ...).
- Room temperature.
- Choice of the type of installation (heating, air conditioning).
- Heating temperature setpoint.
- Air conditioning temperature setpoint.

■ Windows contact

The Frost protection / Heat protection setpoint can be activated by a windows contact integrated into the installation. The setpoint on the thermostat is switched when the **Thermostat - windows contact** object is received.

Communication objects



Organisation of control modes

The different types of controls for heating or cooling management have differing levels of priority.

The list below gives the types of controls with their priority level.

Types of controls	Priority level
Thermostat deactivation	1
Windows contact	2
Priority	3
Lock-up	4
Absence / Presence	5
Setpoint selection Automatic control Scene Preset Timer	6

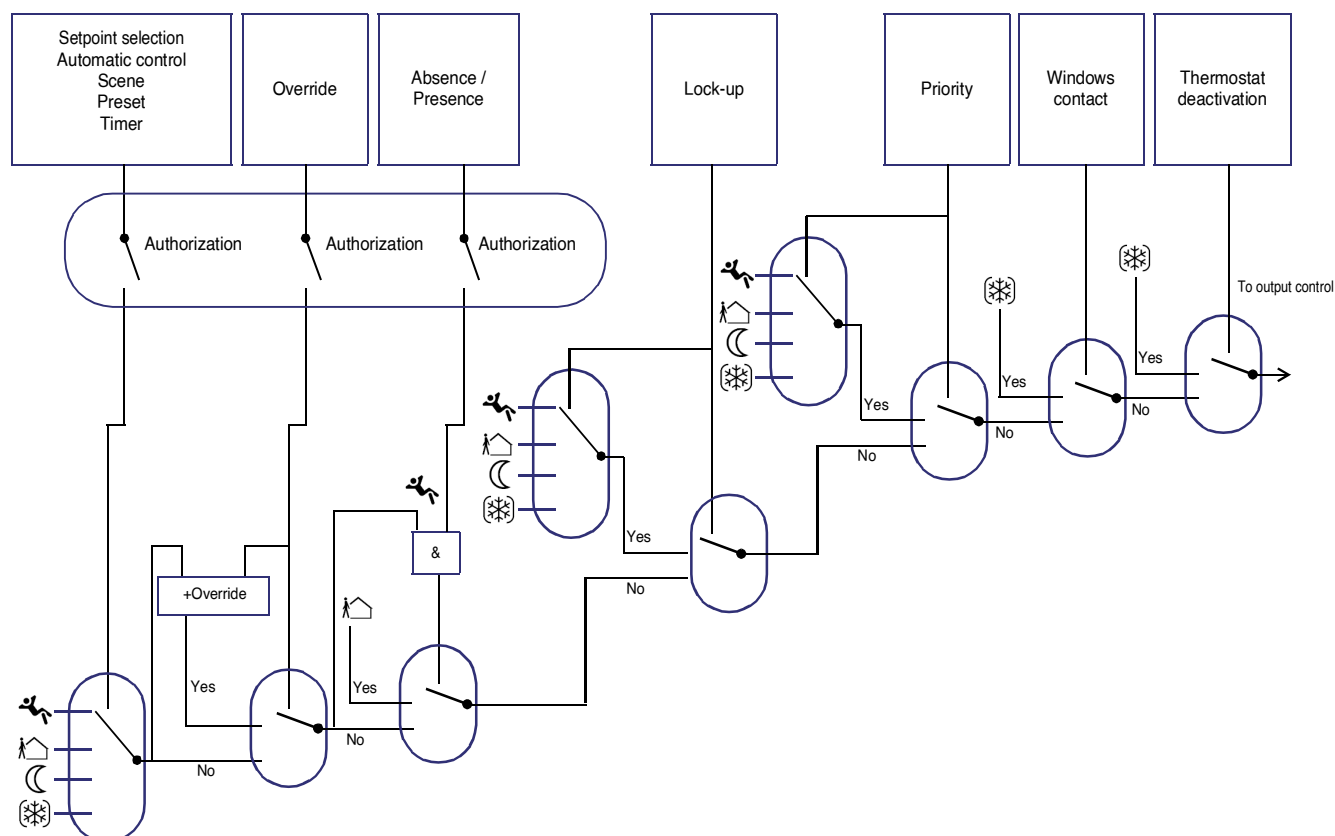

Mode	Symbols
Comfort	
Standby	
Night setpoint	
Frost protection /Heat protection	

* Default value

** Only for TYMS646R

3 Parameters

3.1 Definition of the general parameters

3.1.1 General

This configuration window is used for general configuration of the device.

3.1.1.1 Output configuration

Number of used outputs	6 outputs
Outputs parameters settings	<input type="radio"/> Same configuration for all outputs <input checked="" type="radio"/> Individual configuration
Number of used thermostats	12 thermostats
Manual mode	Active
Status indication	<input type="radio"/> Not active <input checked="" type="radio"/> Active
Logic block 1	<input checked="" type="radio"/> Not active <input type="radio"/> Active
Logic block 2	<input checked="" type="radio"/> Not active <input type="radio"/> Active
Summer/winter mode changeover	<input checked="" type="radio"/> No <input type="radio"/> Yes
Service mode	<input checked="" type="radio"/> No <input type="radio"/> Yes
Device diagnosis object	<input checked="" type="radio"/> No <input type="radio"/> Yes
Device LED switch off object	<input checked="" type="radio"/> No <input type="radio"/> Yes
Date and time request delay at initialization	20 min
Date and time objects	<input checked="" type="radio"/> 1 object (8 bytes) <input type="radio"/> 2 objects (3 bytes + 3 bytes)
<div style="border: 1px solid #ccc; padding: 5px; background-color: #e6f2ff;"> <p>i Restore ETS-params objects: scenes, timer duration, timer setpoint selection, setpoints, hours counter setpoint, valve/pump protection and winter/summer dates</p> </div>	
Restore ETS-params settings	<input type="checkbox"/>
Activ. of restore ETS-parameters object	<input checked="" type="radio"/> Not active <input type="radio"/> Active
Heating activation object	<input type="radio"/> No <input checked="" type="radio"/> Yes
Polarity	<input checked="" type="radio"/> 1 = Heating activ., 0 = Heating deactiv. <input type="radio"/> 1 = Heating deactiv., 0 = Heating activ.
Objects emission delay at bus return	00:00:25 hh:mm:ss

* Default value

** Only for TYMS646R

Parameter	Description	Value
Number of used outputs	This parameter is used to configure the number of outputs which can be used. The product has 6 outputs operating independently, thus allowing 6 heating zones to be controlled.	1 output 2-fold output 3-fold output 4-fold output 5-fold output 6-fold output*

Parameter	Description	Value
Outputs parameters settings	<p>The outputs can be assigned to the same parameters and therefore be configured in the same way.</p> <p>This parameter defines:</p> <ul style="list-style-type: none"> - If all the outputs have to be configured with the same parameters, the visible parameters are automatically used for all the outputs. Only the communication objects are available for each output. This setting must be selected for example when all the actuators must behave in the same way and they must only be controlled by different group addresses. - If all the outputs have to be configured individually, each output has its own parameters tab. 	<p>Same configuration for all outputs</p> <p>Individual configuration*</p>

Parameter	Description	Value
Number of used thermostats**	This parameter is used to configure the number of internal regulators to be used. The product has 12 room temperature thermostats operating independently thus allowing the temperature regulation of up to 12 zones.	No thermostat 1 thermostat 2 thermostats 3 thermostats 4 thermostats 5 thermostats 6 thermostats 7 thermostats 8 thermostats 9 thermostats 10 thermostats 11 thermostats 12 thermostats*

* Default value

** Only for TYMS646R

3.1.1.2 Activation of manual mode

Parameter	Description	Value
Manual mode	Switching to manual mode is not possible.	Not active
	Switching to manual mode is possible without time limit. Manual mode can be activated for a duration that is configurable via the ETS parameters. After expiry of the time limit, manual mode is no longer active.	Active* Time limited

For configuration see section: [Manual mode](#).

3.1.1.3 Activation of the Status indication

Parameter	Description	Value
Status indication	The Status indications parameter register is hidden.	Not active
	The Status indications parameter register is displayed.	Active*

For configuration see section: [Status valve outputs](#).

3.1.1.4 Activation of the logic blocks

Parameter	Description	Value
Logic block 1	Communication object and parameter register Logic block 1 are hidden.	Not active*
	Communication object and parameter register Logic block 1 are displayed.	Active

For configuration see section: [Logic block](#).

Note: The parameters and objects are identical for block 2 ; Only the terms will be adjusted.

For logic block 1

Communication objects: [1372 - Logic block 1 - Input 1](#) (1 Bit - 1.002 DPT_Bool)
 [1376 - Logic block 1 - Logic result](#) (1 Bit - 1.002 DPT_Bool)

For logic block 2

Communication objects: [1378 - Logic block 2 - Input 1](#) (1 Bit - 1.002 DPT_Bool)
 [1382 - Logic block 2 - Logic result](#) (1 Bit - 1.002 DPT_Bool)

* Default value

** Only for TYMS646R

3.1.1.5 Summer/winter mode

Summer/winter mode changeover	<input type="radio"/> No <input checked="" type="radio"/> Yes
Summer/winter changeover mode	<input checked="" type="radio"/> By date <input type="radio"/> Through object
<div style="border: 1px solid #ccc; padding: 5px; background-color: #e6f2ff;"> <p>i Activate the parameter "Restore ETS-params settings" in General / General so that the parameter value is taken into account after next download.</p> </div>	
Winter/summer changeover date	April ▼ 15 ▼
Summer/winter changeover date	October ▼ 15 ▼
Summer/winter mode after ETS download	No change ▼

Parameter	Description	Value
Summer/winter mode changeover	Different parameter values can be configured for an output, depending on the season. The objects and the associated parameters are hidden. The objects and the associated parameters are displayed.	No* Yes

Parameter	Description	Value
Summer/winter changeover mode	This parameter defines the summer/winter changeover. The summer/winter changeover is made using the summer time to winter time changeover date and the winter time to summer time changeover date. These dates are sent via 2 communication objects. The summer/winter changeover is carried out using a 1 bit communication object indicating summer time or winter time.	By date* Through object

■ Summer/winter switch by date

Parameter	Description	Value
Winter/summer changeover date	This parameter defines the winter to summer changeover date: - By entering a month of the year. - By entering a day of the month.	January ... April* ... December 1 ... 14* ... 31
Summer/winter changeover date	This parameter defines the summer to winter changeover date: - By entering a month of the year. - By entering a day of the month.	January ... October* ... December 1 ... 14* ... 31

*Note: This parameter is only visible when the **Summer/winter mode changeover** parameter as the value **Yes** and the **Summer/winter changeover mode** parameter has the value **By date**.*

* Default value

** Only for TYMS646R

These dates can also be modified using the following objects:

Communication objects: **164 - General - Summer/winter changeover date** (3 - Byte - 11.01 DPT_Date)
 165 - General - Winter/summer changeover date (3 - Byte - 11.01 DPT_Date)

■ Summer/winter changeover through object

No additional parameter is displayed for this mode. Only the following object is displayed.

Communication object: **163 - General - Summer/winter mode changeover** (1 - Bit - 1.001 DPT_Switch)

Parameter	Description	Value
Polarity	The Summer/winter mode changeover object receives: 0 = Winter mode is activated. 1 = Summer mode is activated. 0 = Summer mode is activated. 1 = Winter mode is activated.	1 = Summer, 0 = Winter* 1 = Winter, 0 = Summer

Parameter	Description	Value
Summer/winter mode after ETS download	Summer or winter mode is saved in the device and restored after a device reset (bus or mains power return). This parameter defines the operating mode active after a ETS download. The product activates summer mode after a ETS download. The value saved in the device is thus overwritten. The product activates winter mode after a ETS download. The value saved in the device is thus overwritten. The product activates the last operating mode saved.	Summer Winter No change*

* Default value

** Only for TYMS646R

3.1.1.6 Service mode

For installation or maintenance reasons, it is possible to block the outputs in a predefined status. If the service mode is active, the outputs in question are in completely closed or open position, thus blocking any other control.

Service mode	<input type="radio"/> No <input checked="" type="radio"/> Yes
Polarity	<input checked="" type="radio"/> 1 = Service mode active, 0 = Service mode not... <input type="radio"/> 1 = Service mode not active, 0 = Service mode...
Emission	On status change ▼
Behaviour after service mode	
Output 1	Theoretical status without service mode ▼
Output 2	Theoretical status without service mode ▼
Output 3	Theoretical status without service mode ▼
Output 4	Theoretical status without service mode ▼
Output 5	Theoretical status without service mode ▼
Output 6	Theoretical status without service mode ▼

Parameter	Description	Value
Service mode	The Service mode object and all the parameters linked to the function are: Hidden. Priority mode is unavailable. No output can be assigned to the service mode in ETS. Displayed. Priority mode is authorised. The outputs can be assigned to the service mode in ETS.	Not active* Active

The device reacts to telegrams received via the **Service mode** object according to the table below:

Telegram received on the Service mode object			Output behaviour
Hexadecimal Value	Binary Value		
	Bit1 (MSB)	Bit0 (LSB)	
00	0	0	Service mode deactivated
01	0	1	Service mode deactivated
02	1	0	Service mode activated, valves closed
03	1	1	Service mode activated, valves open

Bit 1 of the telegram activates service mode with the value 1. The valve outputs assigned are then locked in the status predefined by bit 0 (0 = closed and 1 = open). The value 0 in bit 1 deactivates service mode again.

Communication objects: **164 - General - Service mode** (2 Bit - 2.001 DPT_Switch_Control)
165 - General - Status indication service mode (1 Bit - 1.002 DPT_Bool)

Parameter	Description	Value
Emission	The Status indication service mode object is sent on the bus: On each change. Periodically after a configurable time. On change and periodically after a configurable time.	On status change* Periodically On status change and periodically

Parameter	Description	Value
Periodicity	This parameter determines the time between each transmission of the Status indication service mode object.	00:00:01 ... 00:10:00* ... 23:59:59 (hh:mm:ss)

*Note: This parameter is only visible if the **Emission** parameter has the following value: **Periodically** or **On status change and periodically**.*

Parameter	Description	Value
Polarity	The Status indication service mode object sends: 1 during service mode activation. 0 during service mode deactivation. 1 during service mode deactivation. 0 during service mode activation.	1 = Service mode active, 0 = Service mode not active* 1 = Service mode not active, 0 = Service mode active

■ Behaviour after service mode

Parameter	Description	Value
Output X	This parameter defines the behaviour to follow at the end of service mode. The output status remains unchanged. All the output valves close. All the output valves open. The valves switch to the position which would be active if no service mode had taken place.	No change Closed Opened Theoretical status without service mode*

X = 1 ... 6

*Note: This parameter is only visible when the **Service mode** parameter has the value: **Active**.*

* Default value

** Only for TYMS646R

3.1.1.7 Diagnosis

The **Device diagnosis** object allows notifications about the operating status of the device to be sent via the KNX bus. This information is sent periodically and/or on status change.

The **Device diagnosis** object allows reporting of current faults according to the device and application. It also allows sending of the position of the switch on the front of the device and the number of the output that is affected by the fault(s).

The **Device Diagnosis** object is a 6-byte object that is composed as described below:

Byte number	6 (MSB)	5	4	3	2	1 (LSB)
Use	Switch position	Application type	Output number	Error codes		

Details of the byte:

- **Bytes 1 to 4:** Correspond to the error codes.

MSB																												LSB							
b31	b30	b29	b28	b27	b26	b25	b24	b23	b22	b21	b20	b19	b18	b17	b16	b15	b14	b13	b12	b11	b10	b9	b8	b7	b6	b5	b4	b3	b2	b1	b0				
X	X	29	X	X	X	25	X	X	X	X	X	X	X	X	X	X	X	X	12	11	X	X	8	X	X	X	X	X	X	X	X				

N°	Faults
29	Overcurrent on the output concerned: The output current flowing through the output contact is too high.
25	Power supply fault: The device no longer has its 24 or 230V~ power supply.
12	Thermostat fault: The connection between the thermostat and the valve outlet has been interrupted.
11	Load shedding: The device has detected an overload or a short circuit on one of the outlet groups (1-3 or 4-6). This bit sends notification of load shedding on the channel to detect the defective output.
8	Excessive number of restarts: This bit is used for notification of repeated restarts and/or a restart triggered by a Watch-Dog. Such a restart is not necessarily apparent to the user from the function, rather it is manifest as a disturbed environment or a bad contact of the power supply.

Note: The use of the standard bit depends on the type of device used (switch actuator, dimmer, shutter/blind, etc.). Certain bits are the same for all devices and others are application-specific.

Byte 5: Corresponds to the application type and the number of the output affected by the error.

MSB				LSB			
b7	b6	b5	b4	b3	b2	b1	b0
Application type				Output number			
0 = Not defined				0 = Device error			
1 = Switch actuator				1 = Output 1			
2 = Shutter/blind				2 = Output 2			
3 = Dimmer						
4 = Switch actuator with current monitoring							
5 = Heating							
				Y = Output Y			

Note: Y is the placeholder for the maximum number of outputs.

* Default value

** Only for TYMS646R

Byte 6: Switch position.

MSB LSB

b7	b6	b5	b4	b3	b2	b1	b0
X	X	X	X	X	X	X	1

1: 0 = Automatic mode / 1 = Manual mode

Note: Bit marked with an x are not used.

Device diagnosis object No Yes

Emission

Emission period hh:mm:ss

Parameter	Description	Value
Device diagnosis object	The Device diagnosis parameter register and the associated communication object is hidden.	No*
	The Device diagnosis parameter register and the associated communication object are displayed.	Yes

Communication object: [1391 - General - Diagnosis \(6 Byte - 219.001 DPT Alarm info\)](#)

Parameter	Description	Value
Emission	The Device diagnosis communication object is sent to bus:	On status change* Periodically On status change and periodically
	On each change.	
	Periodically after a configurable time.	
	On change and periodically after a configurable time.	

Parameter	Description	Value
Periodicity	This parameter determines the time between the individual transmissions of the Device diagnosis object.	00:00:01 ... 00:30:00* ... 23:59:59 (hh:mm:ss)

*Note: This parameter is only visible if the **Emission** parameter has the following value: **Periodically** or **On status change and periodically**.*

3.1.1.8 LED display

Parameter	Description	Value
Device LED switch off object	The Device LEDs lock-up communication object is hidden.	Not active*
	The Device LEDs lock-up communication object is displayed.	Active

This function is used to reduce the overall power consumption of the device. It allows the LEDs on the front of the device to be switched off.

Communication object: [1391 - General - Device LED switch off \(1 Bit - 1.001 DPT_Switch\)](#)

Parameter	Description	Value
Polarity	Object Device LED lock receives: 0 = The LED display is activated. 1 = The LED display is deactivated. 0 = The LED display is deactivated. 1 = The LED display is activated.	0 = Status indication, 1 = Always OFF 0 = Always OFF, 1 = Status indication*

*Note: This parameter is only visible if the parameter **Device LED switch off object** has the following value: **Active**.*

3.1.1.9 Date and time format

Parameter	Description	Value
Date and time request delay at initialization	This parameter determines the time after which a request is sent for a date and time request if they have not been received before.	0 ... 20* ... 255 min

Communication object: [1391 - General - Date and time request \(1 - Bit - 1.017 DPT_Trigger\)](#)

Parameter	Description	Value
Date and time objects	This parameter determines the format of the Date and time object.	
	The Date and time object is defined by an 8 byte object.	1 object (8 byte)*
	The Date and time object is defined by 2 objects of 3 bytes each.	2 Objects (3 byte + 3 byte)

* Default value

** Only for TYMS646R

- 1 object (8 byte)

Communication object: **1385 - General - Date and time (8 - Byte - 19.001 DPT_DateTime)**

- 2 Objects (3 byte + 3 byte)

Communication objects: **1383 - General - Date (3 - Byte - 11.01 DPT_Date)**

1384 - General - Time (3 - Byte - 10.01 DPT_TimeOfDay)

3.1.1.10 Restore ETS-Parameters

There are 2 types of parameters in the device:

- Parameters that can only be changed via ETS.
- Parameters that can be changed via ETS or via the KNX bus.

For parameters that can be changed via ETS and via the KNX bus, 2 values are stored in the device memory: The value corresponding to the ETS-parameter and the currently used value.

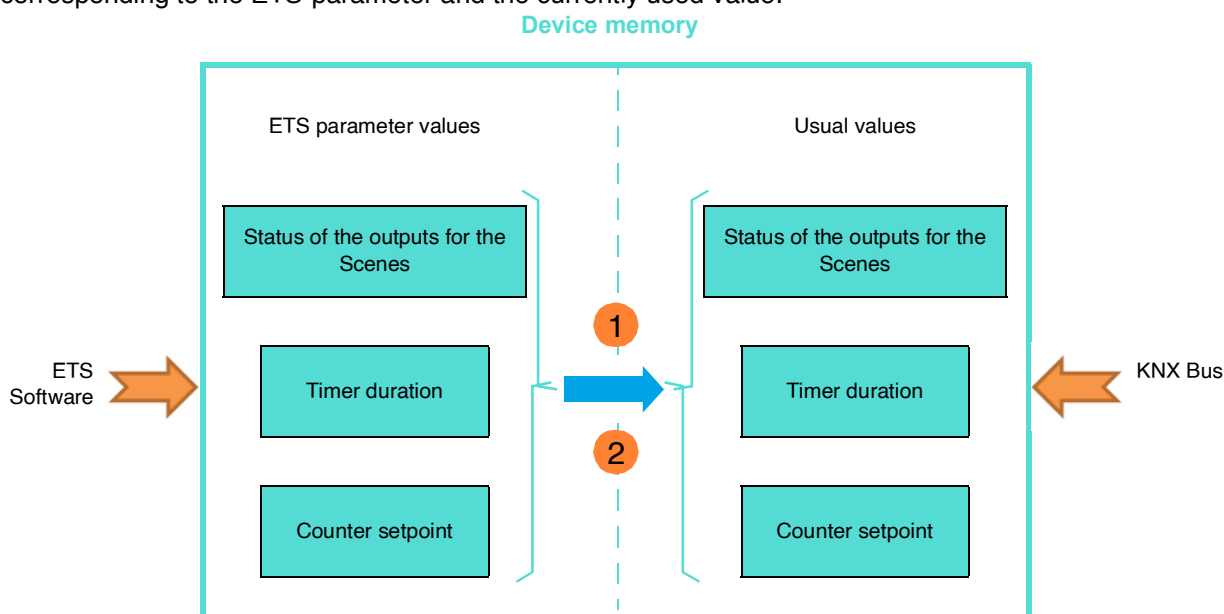

- 1 Receipt of the value 1 on the object, Resets the ETS parameter values:** Current parameter values are replaced by the ETS-parameter values.
- 2 Download of the ETS application:** Current parameter values are replaced by the ETS parameter values on download.

Parameter	Description	Value
Activ. of restore ETS-parameters object (scenes, timer, setpoints)	The Restore ETS-params settings communication object is hidden.	Not active*
	The Restore ETS-params settings communication object is displayed.	Active
	On receipt of a 1 on this object, the parameters*** that are adjustable via the bus are overwritten with values set in the ETS before the last download.	

*** Output status for scene X, Timer, Hours counter setpoint, Valve and pump protection, Date of summer/winger changeover, Setpoints.

Communication object: [1389 - General - Restore ETS-params settings \(1 Bit - 1.015 DPT_Reset\)](#)

3.1.1.11 Heating activation

This function is used to control the activation and deactivation of all the valve outputs at the same time by the KNX bus.

Communication object: [182 - General - Heating activation \(1 Bit - 1.001 DPT_Switch\)](#)

Parameter	Description	Value
Polarity	<p>The Heating activation object receives:</p> <p>1 = All the valve outputs are activated. The outputs operate normally. 0 = All the valve outputs are deactivated. The value of the outputs switches to 0%.</p> <p>1 =All the valve outputs are deactivated. The value of the outputs switches to 0%. 0 = All the valve outputs are activated. The outputs operate normally.</p>	<p>1 = Heating activ., 0 = Heating deactiv.*</p> <p>1 = Heating deactiv., 0 = Heating activ.</p>

3.1.1.12 Objects emission delay at bus return

In order to avoid overloading the KNX bus during a system restart, emission of the communication objects can be delayed.

Parameter	Description	Value
Objects emission delay at bus return	This parameter determines the time after which the object values must be sent on KNX bus return.	00:00:01 ... 00:00:25* ... 12:00:00 (hh:mm:ss)

* Default value

** Only for TYMS646R

3.1.2 Valve / Pumps

Voltage failure status indication	
Valves operating voltage failure object	<input checked="" type="radio"/> No <input type="radio"/> Yes
Short circuit/Overload status indication	
Short circuit/overload reset object	<input checked="" type="radio"/> No <input type="radio"/> Yes
Heat requirement	
Heat requirement	<input type="radio"/> No <input checked="" type="radio"/> Yes
Polarity	<input checked="" type="radio"/> 1 = Heat requirement, 0 = No heat requirement <input type="radio"/> 1 = No heat requirement, 0 = Heat requirement
Emission	On status change and periodically
Emission period	00:10:00 hh:mm:ss
Threshold value for heat requirement sending	1 %
Hysteresis value for heat requirement sending	1 %
<p>i Heat activated if command value > threshold value + hysteresis Heat deactivated if command value <= threshold value</p>	
Heat requirement activation delay	00:05:00 hh:mm:ss
Heat requirement deactivation delay	00:00:00 hh:mm:ss
External heat requirement	<input checked="" type="radio"/> No <input type="radio"/> Yes
Largest command value	
Largest command value	<input checked="" type="radio"/> No <input type="radio"/> Yes
Pump control	
Pump control	<input type="radio"/> No <input checked="" type="radio"/> Yes
Polarity	<input checked="" type="radio"/> 1 = Pump ON, 0 = Pump OFF <input type="radio"/> 1 = Pump OFF, 0 = Pump ON
Emission	On status change and periodically
Emission period	00:10:00 hh:mm:ss
Threshold value for pump control sending	1 %
Hysteresis value for heat requirement sending	1 %
<p>i Pump activated if command value > threshold value + hysteresis Pump deactivated if command value <= threshold value</p>	
Pump activation delay	00:05:00 hh:mm:ss
Pump deactivation delay	00:00:00 hh:mm:ss
External pump control	<input checked="" type="radio"/> No <input type="radio"/> Yes
Pump protection	
Pump protection	<input checked="" type="radio"/> No <input type="radio"/> Yes

3.1.2.1 Short circuit/Overload status indication

Voltage failure status indication

Valves operating voltage failure object No Yes

Polarity 1 = Failure, 0 = No failure
 1 = No failure, 0 = Failure

Emission

Emission period hh:mm:ss

Short circuit/Overload status indication

Short circuit/overload reset object No Yes

Parameter	Description	Value
Valves operating voltage failure object	The product monitors the power supply on the valves. In case of failure, a notification telegram can be sent.	
	The valves operating voltage failure indication is deactivated. The Valves operating voltage failure object is hidden.	No*
	The valves operating voltage failure indication is activated. The Valves operating voltage failure object is displayed.	Yes

Communication object: [166 - General - Valves operating voltage failure \(1 Bit - 1.005 DPT_Alarm\)](#)

Parameter	Description	Value
Polarity	The Valves operating voltage failure object sends: 1 = The power supply to the valves is faulty. 0 = The power supply to the valves is correct. 1 = The power supply to the valves is correct. 0 = The power supply to the valves is faulty.	1 = Failure, 0 = No failure* 1 = No failure, 0 = Failure

*Note: This parameter is only visible if the **Valves operating voltage failure object** parameter has the value **Yes***

Parameter	Description	Value
Emission	<p>The Valves operating voltage failure object is sent on the bus:</p> <p>On each change.</p> <p>Periodically after a configurable time.</p> <p>On change and periodically after a configurable time.</p>	<p>On status change</p> <p>Periodically</p> <p>On status change and periodically*</p>

*Note: This parameter is only visible if the **Valves operating voltage failure object** parameter has the value **Yes**.*

Parameter	Description	Value
Periodicity	This parameter determines the time between each time the Valves operating voltage failure object is sent.	00:00:01 ... 00:10:00* ... 23:59:59 (hh:mm:ss)

*Note: This parameter is only visible if the **Emission** parameter has the following value : **Periodically** or **On status change and periodically**.*

The product can detect an overload or a short circuit on the outputs. The outputs which are short-circuited or permanently overloaded are deactivated after an identification phase. In this case, a short circuit or overload message can be sent on the KNX bus.

Parameter	Description	Value
Valves operating voltage failure object	<p>This parameter defines if a global reset of the short circuit or overload messages on all the outputs is possible.</p> <p>The Reset short circuit/overload object is hidden.</p> <p>The Reset short circuit/overload object is displayed.</p>	<p>No*</p> <p>Yes</p>

Communication object: [167 - General - Reset short circuit/overload \(1 Bit - 1.002 DPT_Boolean\)](#)

Note: The short circuit / overload messages can be reset via the object only if the waiting time and the duration of the test cycle for the outputs in question are finished.

* Default value

** Only for TYMS646R

3.1.2.2 Heat requirement

The product itself can evaluate the parameters of its outputs and transmit a general heating requirement according to a monitoring limit value. With the help of an ON/OFF switch, it is therefore possible to create a heating control on boilers with adapted inputs.

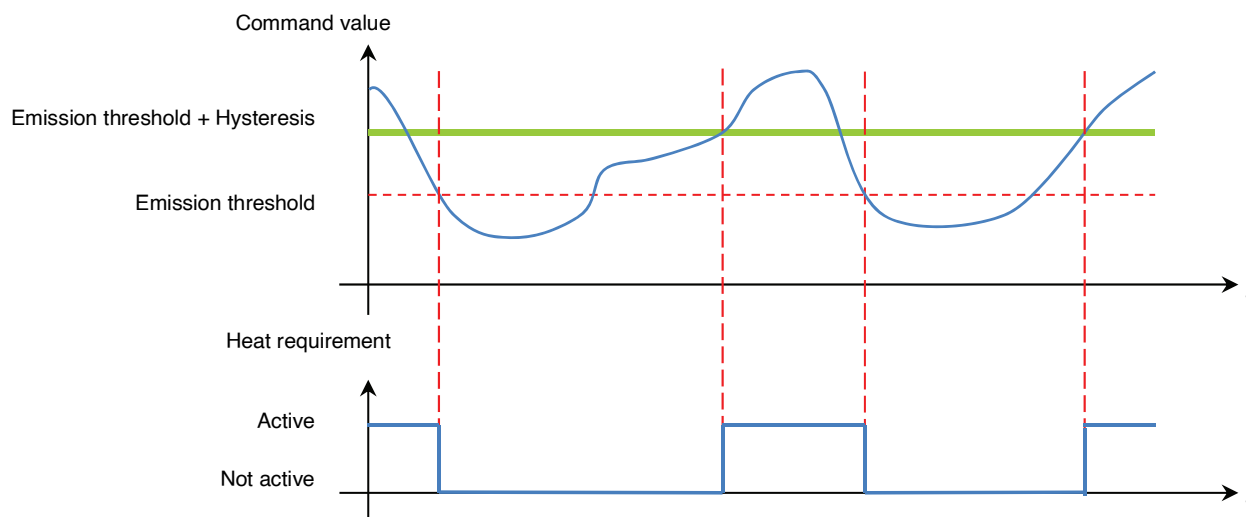

A heat requirement is indicated by the product only if one of the configured values for the assigned outputs exceeds one of the limit values defined with added hysteresis. Cancellation of a heat requirement message occurs as soon as the value falls below the limit value.

Heat requirement

Heat requirement No Yes

Polarity 1 = Heat requirement, 0 = No heat requirement
 1 = No heat requirement, 0 = Heat requirement

Emission

Emission period hh:mm:ss

Threshold value for heat requirement sending %

Hysteresis value for heat requirement sending %

i Heat activated if command value > threshold value + hysteresis
 Heat deactivated if command value <= threshold value

Heat requirement activation delay hh:mm:ss

Heat requirement deactivation delay hh:mm:ss

External heat requirement No Yes

* Default value

** Only for TYMS646R

Parameter	Description	Value
Heat requirement	The heat control is deactivated. The Heat requirement object is hidden.	No
	The heat control is activated. The Heat requirement object is displayed.	Yes*

Communication object: [168 - General - Heat requirement \(1 Bit - 1.002 DPT_Boolean\)](#)

Note: The outputs must be assigned individually to the heating requirement control in the output parameter menu (output x - Function selection) so that they are taken into account in the needs assessment.

Parameter	Description	Value
Emission	The Heat requirement object is sent on the bus:	On status change Periodically On status change and periodically*
	On each change.	
	Periodically after a configurable time.	
	On change and periodically after a configurable time.	

*Note: This parameter is only visible when the **Heat requirement** parameter has the value **Yes**.*

Parameter	Description	Value
Periodicity	This parameter determines the time between each transmission of the Heat requirement object.	00:00:01 ... 00:10:00* ... 23:59:59 (hh:mm:ss)

*Note: This parameter is only visible if the **Emission** parameter has the following value : **Periodically** or **On status change and periodically**.*

Parameter	Description	Value
Polarity	The Heat requirement object sends: 1 = A heat requirement is sent. 0 = No heat requirement is necessary.	1 = Heat requirement, 0 = No heat requirement* 1 = No heat requirement, 0 = Heat requirement
	1 = No heat requirement is necessary 0 = A heat requirement is sent.	

*Note: This parameter is only visible when the **Heat requirement** parameter has the value **Yes**.*

* Default value

** Only for TYMS646R

Parameter	Description	Value
Threshold value for heat requirement sending (0-100%)	This parameter defines the heat requirement transmission threshold.	0* ... 100

Parameter	Description	Value
Hysteresis value for heat requirement sending (1-20%)	This parameter defines the hysteresis of the heat requirement transmission threshold. The heat requirement is only active if the value exceeds the threshold with this hysteresis added.	1* ... 20

Parameter	Description	Value
Heat requirement activation delay	This parameter defines the time after which the heat requirement telegram is sent on the KNX bus.	00:00:00 ... 00:05:00* ... 12:00:00 (hh:mm:ss)

Parameter	Description	Value
Heat requirement deactivation delay	This parameter defines the time after which the heat requirement cancellation is sent on the KNX bus.	00:00:00* ... 12:00:00 (hh:mm:ss)

Parameter	Description	Value
External heat requirement	<p>The product can evaluate an external heat requirement from another heating actuator for example. It connects the external telegram and the internal status of the individual heat requirement logically by the OR function. It sends the result of this operation via the Heat requirement object.</p> <p>The External heat requirement object is hidden.</p> <p>The External heat requirement is displayed.</p>	<p>Not active*</p> <p>Active</p>

Communication object: [169 - General - External heat requirement \(1 Bit - 1.002 DPT_Boolean\)](#)

* Default value

** Only for TYMS646R

3.1.2.3 Largest command value

Thanks to the evaluation of the largest command value in the heating or cooling system, the product makes it possible to influence the energy consumption of a building or house.

The information about the largest setpoint value can be made available to the heating or cooling system to determine the optimum starting temperature for example.

If the function is activated, the product evaluates all the active command values of the valve outputs and sends the largest command value received externally.

Largest command value

Largest command value No Yes

i Only continuous command values (1 byte) are accounted

Emission On status change and periodically ▾

Value emission by variation of %

Emission period hh:mm:ss

External largest command value No Yes

Parameter	Description	Value
Largest command value	Evaluation of the largest command value is deactivated. The Largest command value object is hidden.	No*
	Evaluation of the largest command value is activated. The Largest command value object is displayed.	Yes

Communication object: [170 - General - Largest command value \(8 Bit - 5.001 DPT_Percentage\)](#)

Parameter	Description	Value
Emission	<p>The Largest command value object is sent on the bus.</p> <p>On each change.</p> <p>Periodically after a configurable time.</p> <p>On change and periodically after a configurable time.</p>	<p>On status change</p> <p>Periodically</p> <p>On status change and periodically*</p>

Parameter	Description	Value
Value emission by variation of	This parameter determines the dimming value beyond which the Largest command value object is sent.	1 ... 3* ... 100%

*Note: This parameter is only visible if the **Emission** parameter has the following value : **On status change** or **On status change and periodically**.*

Parameter	Description	Value
Periodicity	This parameter determines the time between each transmission of the Largest command value object.	00:00:01 ... 00:10:00* ... 23:59:59 (hh:mm:ss)

*Note: This parameter is only visible if the **Emission** parameter has the following value : **Periodically** or **On status change and periodically**.*

Parameter	Description	Value
External largest command value	The product can evaluate a maximum external command value from another heating actuator for example. It monitors the external telegram, taking into account its own active parameters. It sends the result of this operation via the Largest command value object.	
	The External largest command value object is hidden.	No*
	The External largest command value object is displayed.	Yes

Communication object: [171 - General - External largest command value \(8 Bit - 5.001 DPT_Percentage\)](#)

3.1.2.4 Pump control

The product can be used to control a heating or cooling circuit circulation pump using an ON/OFF switch. This control is carried out using the **Pump ON/OFF** object.

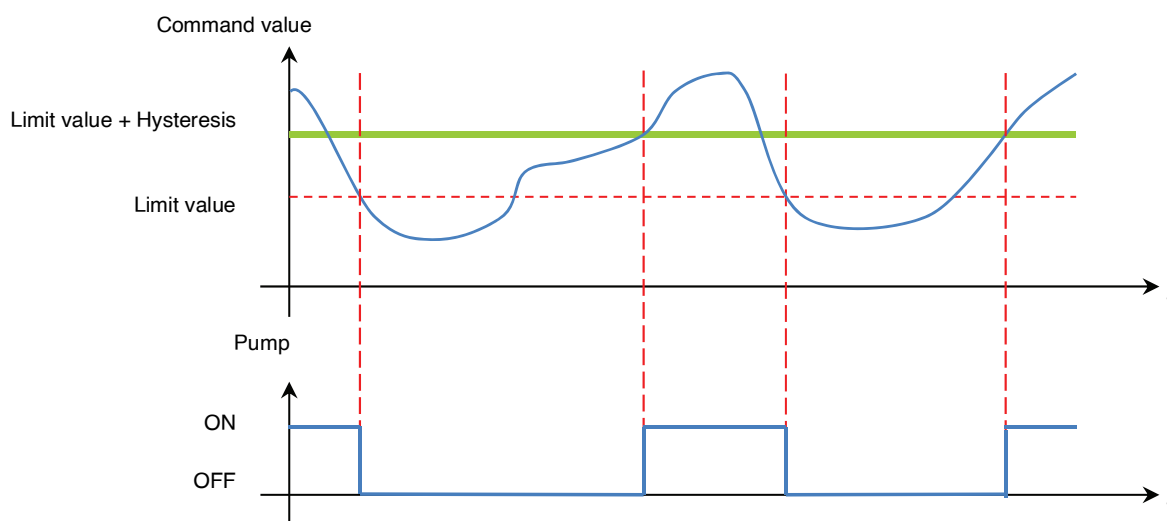

This object is used to send a pump control for the device on the KNX bus for the direct control of a heating or cooling circulation pump. The pump is activated by the product only if one of the configured values for the assigned outputs exceeds one of the defined limit values with the addition of the hysteresis. Pump deactivation occurs as soon as the value falls below the limit value.

Pump control

Pump control No Yes

Polarity 1 = Pump ON, 0 = Pump OFF
 1 = Pump OFF, 0 = Pump ON

Emission On status change and periodically

Emission period 00:10:00 hh:mm:ss

Threshold value for pump control sending 1 %

Hysteresis value for heat requirement sending 1 %

i Pump activated if command value > threshold value + hysteresis
Pump deactivated if command value <= threshold value

Pump activation delay 00:05:00 hh:mm:ss

Pump deactivation delay 00:00:00 hh:mm:ss

External pump control No Yes

* Default value

** Only for TYMS646R

Parameter	Description	Value
Pump control	Pump control is deactivated. The Pump ON/OFF object is hidden.	No*
	Pump control is activated. The Pump ON/OFF object is displayed.	Yes

Communication object: **174 - General - Pump ON/OFF (1 Bit - 1.001 DPT_Switch)**

Note: The outputs must be assigned individually to the pump control in the output configuration menu (output x - Function selection), so that they are taken into account in the control.

Parameter	Description	Value
Emission	The Pump ON/OFF object is sent on the bus.	On status change Periodically On status change and periodically*
	On each change.	
	Periodically after a configurable time.	
	On change and periodically after a configurable time.	

Parameter	Description	Value
Periodicity	This parameter determines the time between each transmission of the Pump ON/OFF object.	00:00:01 ... 00:10:00* ... 23:59:59 (hh:mm:ss)

*Note: This parameter is only visible if the **Emission** parameter has the following value : **Periodically** or **On status change and periodically**.*

Parameter	Description	Value
Polarity	The Pump ON/OFF object sends:	1 = Pump ON, 0 = Pump OFF* 1 = Pump OFF, 0 = Pump ON
	1 = Start-up of the circulation pump. 0 = Stoppage of the circulation pump.	
	1 = Stoppage of the circulation pump. 0 = Start-up of the circulation pump.	

*Note: This parameter is only visible when the **Pump control** parameter has the value **Yes**.*

* Default value

** Only for TYMS646R

Parameter	Description	Value
External pump control	<p>The product can evaluate an External pump control signal from another heating actuator for example. It connects the external telegram and the internal status of the pump logically by the OR function. It sends the result of this operation via the Pump ON/OFF object.</p> <p>The External pump control object is hidden.</p> <p>The External pump control object is displayed.</p>	<p>No*</p> <p>Yes</p>

Communication object: [175 - General - External pump control \(1 Bit - 1.001 DPT_Switch\)](#)

Parameter	Description	Value
Threshold value for pump control sending (0-100%)	This parameter defines the pump control transmission threshold.	0 ... 1* ... 100

Parameter	Description	Value
Hysteresis value for pump control sending (1-20%)	This parameter defines the hysteresis of the pump control transmission threshold. The pump control is only active when the value exceeds the threshold with the addition of this hysteresis.	1* ... 20

Parameter	Description	Value
Pump activation delay	This parameter defines the time after which the pump start-up telegram is sent on the KNX bus.	00:00:00 ... 00:05:00* ... 12:00:00 (hh:mm:ss)

Parameter	Description	Value
Pump deactivation delay	This parameter defines the time after which the pump shut-down telegram is sent on the KNX bus.	00:00:00* ... 12:00:00 (hh:mm:ss)

* Default value

** Only for TYMS646R

3.1.2.5 Pump protection

If a heating or cooling circuit circulation pump does not operate for a long period, it can seize up. This function is used to send a control to actuate the pump during a configurable period. The frequency of this control is also configurable.

Pump protection

Pump protection No Yes

i Activate the parameter "Restore ETS-params settings" in General / General so that the parameter value is taken into account after next download.

Pump protection activation ▼ Periodically

Periodicity ▼ Every week

Pump protection duration ▲▼ 5 Minutes

Smart pump protection No Yes

Parameter	Description	Value
Pump protection	The pump protection function is deactivated. The associated parameters and objects are hidden.	No*
	The pump protection function is activated. The associated parameters and objects are displayed.	Yes

Parameter	Description	Value
Pump protection activation	Pump protection activation is triggered.	Periodically*
	Periodically according to a configurable cycle duration.	Periodically starting at a specified date/time
	Periodically according to a configurable cycle duration and with a defined date and time of first activation.	Through object
	Using the Pump protection start/stop object.	

*Note: Pump protection stops after a configurable duration or using the **Pump protection start/stop** object.*

* Default value

** Only for TYMS646R

- Periodically

Parameter	Description	Value
Periodicity	This parameter determines the time between each pump protection activation.	Every day Every week* Every 3 weeks Every month Every 2 months Every 3 months Every 6 months Every year

*Note: This parameter is only visible if the **Pump protection activation** parameter has the value: **Periodically** or **Periodically starting at a specified date/time**.*

Communication object: [180 - General - Pump protection periodicity \(2 - Byte - 7.007 DPT_TimePeriodHrs\)](#)

- Periodically starting at a specified date/time

Parameter	Description	Value
Periodicity	This parameter determines the time between each pump protection activation.	Every day Every week* Every 3 weeks Every month Every 2 months Every 3 months Every 6 months Every year

*Note: This parameter is only visible if the **Pump protection activation** parameter has the value: **Periodically** or **Periodically starting at a specified date/time**.*

* Default value

** Only for TYMS646R

Parameter	Description	Value
Year	This parameter defines the date and time of first activation of pump protection.	0 ... 1972* ... 4095
Month		January ... March* ... December
Day of the month		1 ... 13* ... 31
Time of first activation		00:00:00* ... 23:59:59 (hh:mm:ss)

Communication objects: [176 - General - Pump protection date \(3 - Byte - 11.001 DPT_Date\)](#)
 [177 - General - Pump protection time \(3 - Byte - 10.001 DPT_TimeOfDay\)](#)
 [178 - General - Pump protection date and time \(8 - Byte - 19.001 DPT_DateTime\)](#)

- Through object
 Pump protection is carried out using an external device by the KNX bus.

Parameter	Description	Value
Pump protection start/stop object polarity	The Pump protection start/stop object receives: 1 = Pump protection starts. 0 = Pump protection stops. 1 = Pump protection stops. 0 = Pump protection starts.	1 = Start, 0 = Stop* 1 = Stop, 0 = Start

*Note: This parameter is only visible if the **Pump protection activation** parameter has the value: **Through object**.
 Note: Pump protection stops after a configurable duration or using the **Pump protection start/stop** object.*

Communication object: [181 - General - Pump protection start/stop \(1 - Bit - 1.010 DPT_Start\)](#)

* Default value

** Only for TYMS646R

- Valve protection duration

Parameter	Description	Value
Valve protection duration	This parameter defines the pump protection operating duration. Pump protection can be stopped before the end of this period using the Pump protection start/stop object.	1 ... 5* ... 15 min

This duration can also be modified using the following object:

Communication object: [179 - General - Pump protection duration \(2 - Byte - 7.006 DPT_TimePeriodMin\)](#)

- Smart valve protection

This function is used to activate pump protection, taking into account the number of activations and the operating time of the pump.

Example: Pump protection activation periodicity: Every week.

Valve protection duration: 5 minutes

When smart pump protection is activated, pump protection is activated if the pump has not been activated for more than 5 minutes over a period of one week.

Parameter	Description	Value
Smart valve protection	The smart pump protection function is deactivated.	Not active
	The smart pump protection function is activated.	Active*

3.1.3 Manual mode

In this mode, the outputs are blocked in a configurable status.

Manual mode is activated by the switch on the front of the device. The **Deactivation of manual mode** object is used to authorise or disallow manual mode.

When manual mode is activated, the outputs switch to OFF.

When the manual mode button of an output is pressed for the first time, the output status LED flashes green, indicating that the level of the output is 50%.

When the button is pressed a second time, the output status LED switches to steady green, indicating that the level of the output is 100%.

When the button is pressed a third time, the output status LED turns off, indicating that the output is OFF.

The behaviour is determined by the following parameters:

* Default value

** Only for TYMS646R

Object deactivation of manual mode	<input type="radio"/> Not active <input checked="" type="radio"/> Active
Polarity	<input checked="" type="radio"/> 0=Manual mode locked-up, 1=Manual mode a... <input type="radio"/> 0=Manual mode authorized, 1=Manual mode l...
Object status indication manual mode	<input type="radio"/> Not active <input checked="" type="radio"/> Active
Polarity	<input checked="" type="radio"/> 0=Manual mode deactivated, 1=Manual mode... <input type="radio"/> 0=Manual mode activated, 1=Manual mode d...
Emission	On status change and periodically
Emission period	00:30:00 hh:mm:ss

3.1.3.1 Duration of manual mode activation

Parameter	Description	Value
Duration of manual mode activation	This parameter defines the amount of time for which manual mode remains activated.	00:01 ... 00:30* ... 23:59 (hh:mm)

Note: This parameter is only visible if the **Manual mode** parameter has the following value: **Time limited**.

3.1.3.2 Deactivation of manual mode

Parameter	Description	Value
Object deactivation of manual mode	The Deactivation of manual mode communication object is hidden.	Not active*
	The Deactivation of manual mode communication object is displayed.	Active

Communication object: [1387 - General - Deactivation of manual mode \(1 - Bit - 1.003 DPT_Enable\)](#)

Parameter	Description	Value
Polarity	The Deactivate manual mode object receives: 0 = Manual mode is activated 1 = Manual mode is not activated 0 = Manual mode is not activated 1 = Manual mode is activated	0 = Manual mode authorized, 1 = Manual mode locked-up 0 = Manual mode locked-up, 1 = Manual mode authorized*

Note: This parameter is only visible if the **Object deactivation of manual mode** parameter has the following value: **Active**.

3.1.3.3 Status indication manual mode

Parameter	Description	Value
Object status indication manual mode	The Status indication manual mode communication object is hidden.	Not active*
	The Status indication manual mode communication object is displayed.	Active

Communication object: [1388 - General - Status indication manual mode \(1 - Bit - 1.003 DPT_Enable\)](#)

Parameter	Description	Value
Polarity	<p>The Status indication manual mode communication object sends:</p> <p>0 = When manual mode is switched on 1 = When manual mode is switched off</p> <p>0 = When manual mode is switched off 1 = When manual mode is switched on</p>	<p>0 = Manual mode activated, 1 = Manual mode deactivated</p> <p>0 = Manual mode deactivated, 1 = Manual mode activated*</p>

*Note: This parameter is only visible if the **Object status indication manual mode** parameter has the following value: **Active**.*

Parameter	Description	Value
Emission	<p>The Status indication manual mode communication object is sent:</p> <p>On switching manual mode on or off. Periodically after a configurable time.</p> <p>On switching manual mode on or off and periodically after a configurable time.</p>	<p>On status change*</p> <p>Periodically</p> <p>On status change and periodically</p>

*Note: This parameter is only visible if the **Object status indication manual mode** parameter has the following value: **Active**.*

Parameter	Description	Value
Periodicity	This parameter determines the time between the individual transmissions of the Status indication manual mode object.	00:00:01 ... 00:30:00* ... 23:59:59 (hh:mm:ss)

*Note: This parameter is only visible if the **Emission** parameter has the following value : **Periodically** or **On status change and periodically**.*

3.1.4 Logic block

The Logic function is used to control the status of an output according to the result of a logic operation. This command has the lowest priority.

The result of the function can be output on the KNX bus and may directly relate to the status of one or more outputs. 2 logic blocks are available for each device.

Operating principle of the logic block:

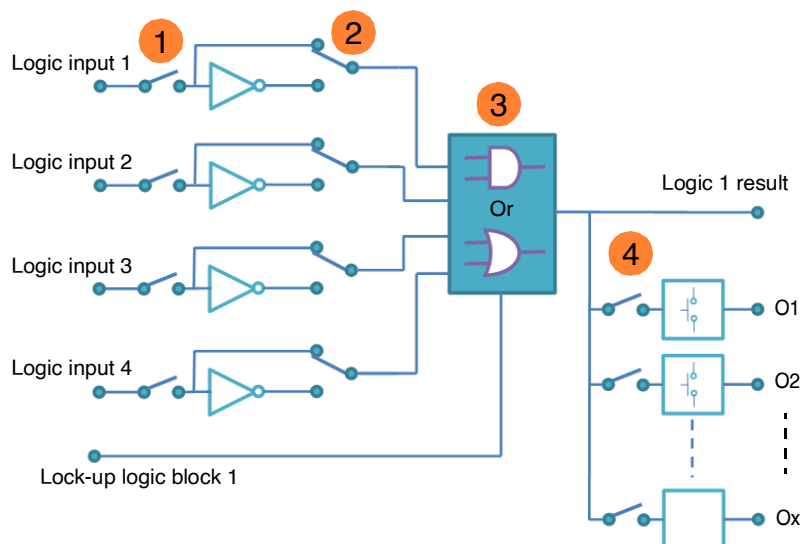

- ❶ Logic input number: Allows authorization of the logic input
- ❷ Logic input value: Inverted, yes or no
- ❸ Type of logic function (AND or OR): Selection of the logic function
- ❹ The logic result is applied to outputs: Selection of the outputs concerned by the logic operation

The behaviour is determined by the following parameters:

Note: The description of the parameters is given for logic block 1. The parameters and objects are identical for logic block 2 ; Only the terms will be adjusted.

Logic function type	<input type="radio"/> AND <input checked="" type="radio"/> OR
Number of logic inputs	4
Inverting value of logic input 1	<input checked="" type="radio"/> Maintain status <input type="radio"/> Status inversion
Inverting value of logic input 2	<input checked="" type="radio"/> Maintain status <input type="radio"/> Status inversion
Inverting value of logic input 3	<input checked="" type="radio"/> Maintain status <input type="radio"/> Status inversion
Inverting value of logic input 4	<input checked="" type="radio"/> Maintain status <input type="radio"/> Status inversion
Value at initialization of logic input 1	Value before initialization
Value at initialization of logic input 2	Value before initialization
Value at initialization of logic input 3	Value before initialization
Value at initialization of logic input 4	Value before initialization
Authorization object logic block	<input type="radio"/> Not active <input checked="" type="radio"/> Active
Value at initialization	Value before initialization
Polarity	<input checked="" type="radio"/> 0 = Locked-up , 1 = Authorized <input type="radio"/> 0 = Authorized, 1 = Locked-up
Logic result after authorisation	<input checked="" type="radio"/> Immediate emission when authorization <input type="radio"/> No immediate emission
Emission of logic result	<input type="radio"/> By input value change <input checked="" type="radio"/> By logic result value change
Logic result acts on thermostats	<input type="radio"/> No <input checked="" type="radio"/> Yes
Thermostat 1	<input checked="" type="radio"/> Not active <input type="radio"/> Active
Thermostat 2	<input checked="" type="radio"/> Not active <input type="radio"/> Active
Thermostat 3	<input checked="" type="radio"/> Not active <input type="radio"/> Active
Thermostat 4	<input checked="" type="radio"/> Not active <input type="radio"/> Active
Thermostat 5	<input checked="" type="radio"/> Not active <input type="radio"/> Active
Thermostat 6	<input checked="" type="radio"/> Not active <input type="radio"/> Active
Thermostat 7	<input checked="" type="radio"/> Not active <input type="radio"/> Active
Thermostat 8	<input checked="" type="radio"/> Not active <input type="radio"/> Active
Thermostat 9	<input checked="" type="radio"/> Not active <input type="radio"/> Active
Thermostat 10	<input checked="" type="radio"/> Not active <input type="radio"/> Active
Thermostat 11	<input checked="" type="radio"/> Not active <input type="radio"/> Active
Thermostat 12	<input checked="" type="radio"/> Not active <input type="radio"/> Active
Action if logic result = 0	Auto
Action if logic result = 1	Auto

* Default value

** Only for TYMS646R

3.1.4.1 Configuration

Parameter	Description	Value
Logic function type	The input objects are: OR linked. AND linked.	Or* And

For logic table see:

Parameter	Description	Value
Number of logic inputs	This parameter determines the number of inputs of the logic block. Up to 4 inputs can be used.	1* 2 3 4

Communication objects:

Block 1	1372 - Logic block 1 - Input 1 (1 Bit -1.002 DPT_Bool) 1373 - Logic block 1 - Input 2 (1 Bit -1.002 DPT_Bool) 1374 - Logic block 1 - Input 3 (1 Bit -1.002 DPT_Bool) 1375 - Logic block 1 - Input 4 (1 Bit -1.002 DPT_Bool)
Block 2	1378 - Logic block 2 - Input 1 (1 Bit -1.002 DPT_Bool) 1379 - Logic block 2 - Input 2 (1 Bit -1.002 DPT_Bool) 1380 - Logic block 2 - Input 3 (1 Bit -1.002 DPT_Bool) 1381 - Logic block 2 - Input 4 (1 Bit -1.002 DPT_Bool)

Parameter	Description	Value
Inverting value of logic input x	The value of logic input x works on the logic block: With its object value (0 = 0, 1 = 1) With inverted object value (0 = 1, 1 = 0)	Maintain status* Status inversion

x = 1 to 4

Parameter	Description	Value
Value at initialization of logic input x	On initialization of the device after a download or after return of the bus power, the value of the logic input is: Set to 0. Set to 1. Set according to the value of the logic input before the initialization occurred.	0 1 Value before initialization*

x = 1 to 4

* Default value

** Only for TYMS646R

3.1.4.2 Logic block authorization

Principle of logic block authorization:

The parameters are set as follows:

- Logic block authorization: 0 = Locked-up, 1 = Authorized.
- Action if logic result = 0 : Night setpoint.
- Action if logic result = 1 : Comfort.
- Logic input 1 and 2 are AND-linked.
- Emission of logic result: By input value change.

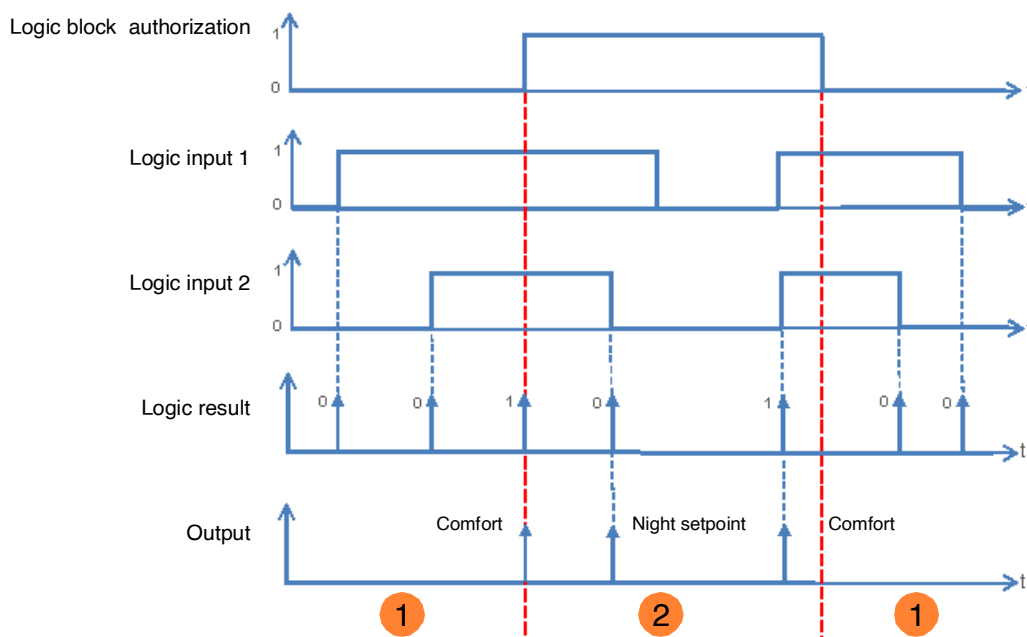

- ① The logic result has no influence on the outputCurrent values.
- ② The commands from the logic result are executed.

*Note: The commands from the logic result are executed immediately after authorization, according to the **Logic result after authorization** parameter.*

Parameter	Description	Value
Authorization object logic block	The Logic block 1 – Authorization communication object and related parameters are hidden.	Not active*
	The Logic block 1 – Authorization communication object and related parameters are displayed.	Active

Note: If the logic block is locked the logic operation is not processed.

Communication objects:

Block 1 **1371 - Logic block 1 - Authorization** (1 Bit - 1.003 DPT_Enable)

Block 2 **1377 - Logic block 2 - Authorization** (1 Bit - 1.003 DPT_Enable)

* Default value

** Only for TYMS646R

Parameter	Description	Value
Value at initialization	On initialization of the device after a download or after return of the bus power, the value of the Logic block 1 – Authorization object is: Set to 0. Set to 1. Set according to the value that the object had before initialization.	0 1 Value before initialization*

*Note: This parameter is only visible if the **Authorization object logic block** parameter has the following value: **Active**.*

Parameter	Description	Value
Polarity	On receipt of a value on the Logic block 1 – Authorization object, this is: Locked-up on object value 1. Locked-up on object value 0.	0 = Authorized, 1 = Locked-up 0 = Locked-up, 1 = Authorized*

*Note: This parameter is only visible if the **Authorization object logic block** parameter has the following value: **Active**.*

Parameter	Description	Value
Logic result after autorisation	On authorization of the logic block: The value of the Logic result is immediately determined. The value of the logic result is first determined after receipt of a value on a logic input.	Immediate emission when authorization* No immediate emission

*Note: This parameter is only visible if the **Authorization object logic block** parameter has the following value: **Active**.*

3.1.4.3 Logic result

Parameter	Description	Value
Emission of logic result	The Logic result object will be sent on: Each receipt of a telegram on one of the logic inputs. A change in the value of the logic result.	By input value change By logic result value change*

Parameter	Description	Value
Logic result acts on thermostats	The logic results acts: Only on the Logic result communication object. On the Logic result communication object and directly on one or more outputs.	Yes No*

The status of the affected outputs is determined by the parameter **action on logic result = x**.

Parameter	Description	Value
Thermostat 1 ... x	The output relationship with the Logic result is: Directly dependent. Independent.	Active Not active*

x = 12

Note: This parameter is only visible when the **Logic result acts on thermostats** parameter has the value: **Yes**.

Parameter	Description	Value
Action if logic result = 0	On the outputs that are directly dependent on Logic result, if the output value = 0, the status: Switches to Auto mode Switches to Comfort mode Switches to standby Switches to night setpoint Switches to Protection mode	Auto Comfort Standby Night setpoint Frost/heat protection

Parameter	Description	Value
Action if logic result = 1	On the outputs that are directly dependent on Logic result, if the output value = 1, the status: Switches to Auto mode Switches to Comfort mode Switches to standby Switches to night setpoint Switches to Protection mode	Auto Comfort Standby Night setpoint Frost/heat protection

* Default value

** Only for TYMS646R

3.1.5 Thermostats assignment

The product TYMS646R has 12 room thermostats incorporated into the software and operating independently with regard to the processes. The thermostat outputs can be connected internally to the valve outputs so that temperature regulation and valve control can be performed using a single device. As the product TYMS646T does not have room thermostats, the outputs can only be controlled by an external thermostat.

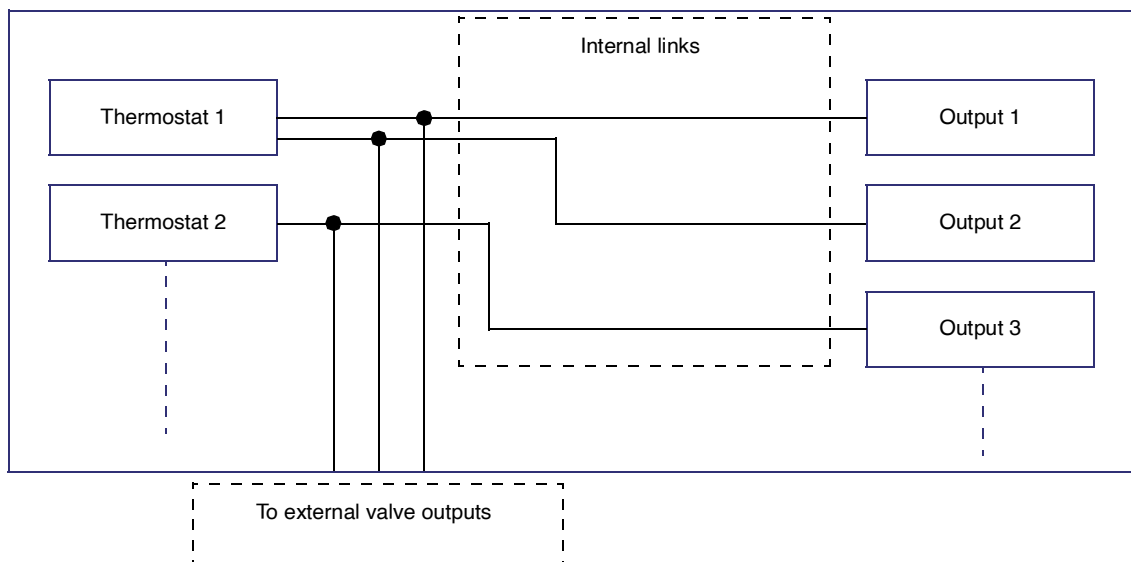

Note: Each valve output can only be connected to a single thermostat.

This function is performed in the **Thermostats assignment** tab.

Output 1 controlled by	External thermostat ▼
Regulation type	Heating ▼
Output 2 controlled by	External thermostat ▼
Regulation type	Heating ▼
Output 3 controlled by	External thermostat ▼
Regulation type	Heating ▼
Output 4 controlled by	External thermostat ▼
Regulation type	Heating ▼
Output 5 controlled by	External thermostat ▼
Regulation type	Heating ▼
Output 6 controlled by	External thermostat ▼
Regulation type	Heating ▼

Parameter	Description	Value
Output X controlled by	<p>This parameter is used to select the thermostat which is to control the output.</p> <p>Regulation is performed with one of the internal thermostats. The communication objects for valve control are hidden.</p> <p>Regulation is performed with an external thermostat. The communication objects for valve control are displayed.</p> <p>The parameters and communication objects concerning the output are hidden.</p>	<p>Thermostat 1 à 12**</p> <p>External thermostat*</p> <p>Not used</p>

Parameter	Description	Value
Regulation type	This parameter is used to select the type of installation controlled by the thermostat.	<p>Heating*</p> <p>Cooling</p> <p>Heating + Cooling</p>

3.1.6 Status valve outputs

To know the real status of a valve output, there are several status indications. This function is used to know the status of an output, whatever operating mode is currently in progress (Manual mode, priority, lock-up, etc.). The parameters below are used to configure the transmission conditions of the status indication objects in question.

Status indication ON/OFF

Emission

Emission period hh:mm:ss

Status valve position

Emission

Value emission by variation of %

Emission period hh:mm:ss

Command value monitoring failure

Emission

Emission period hh:mm:ss

Short circuit/Overload status indication

Emission

Emission period hh:mm:ss

* Default value

** Only for TYMS646R

■ Status indication ON/OFF

Parameter	Description	Value
Emission	<p>The Status indication ON/OFF object is sent on the bus:</p> <p>On each change.</p> <p>Periodically after a configurable time.</p> <p>On change and periodically after a configurable time.</p>	<p>On status change</p> <p>Periodically</p> <p>On status change and periodically*</p>

Note: The object transmission conditions are valid for all the outputs.

Communication objects:

[3, 30, 57, 84, 111, 138](#) - **Output x - Status indication ON/OFF (1 - Bit - 1.001 DPT_Switch)**

Parameter	Description	Value
Periodicity	This parameter determines the time between the individual transmissions of the Status indication ON/OFF object.	00:00:01 ... 00:10:00* ... 23:59:59 (hh:mm:ss)

*Note: This parameter is only visible if the **Emission** parameter has the following value : **Periodically** or **On status change and periodically**.*

■ Status valve position

Parameter	Description	Value
Emission	<p>The Status valve position in % object is sent on the bus:</p> <p>On each change.</p> <p>Periodically after a configurable time.</p> <p>On change and periodically after a configurable time.</p>	<p>On status change</p> <p>Periodically</p> <p>On status change and periodically*</p>

Note: The object transmission conditions are valid for all the outputs.

Communication objects:

[4, 31, 58, 85, 112, 139](#) - **Output x - Status valve position in % (8 - Bit - 5.001 DPT_Scaling)**

Parameter	Description	Value
Periodicity	This parameter determines the time between the individual transmission of the Status valve position in % object.	00:00:01 ... 00:10:00* ... 23:59:59 (hh:mm:ss)

*Note: This parameter is only visible if the **Emission** parameter has the following value : **Periodically** or **On status change and periodically**.*

* Default value

** Only for TYMS646R

■ Command value monitoring failure

Parameter	Description	Value
Emission	<p>The Command value monitoring failure object is sent on the bus:</p> <p>On each change.</p> <p>Periodically after a configurable time.</p> <p>On change and periodically after a configurable time.</p>	<p>On status change</p> <p>Periodically</p> <p>On status change and periodically*</p>

Note: The object transmission conditions are valid for all the outputs.

Communication objects:

[5, 32, 59, 86, 113, 140](#) - **Output x - Command value monitoring failure** (1 - Bit - 1.005 DPT_Alarm)

Parameter	Description	Value
Periodicity	This parameter determines the time between the individual transmission of the Command value monitoring failure object.	00:00:01 ... 00:10:00* ... 23:59:59 (hh:mm:ss)

*Note: This parameter is only visible if the **Emission** parameter has the following value : **Periodically** or **On status change and periodically**.*

■ Short circuit/Overload status indication

Parameter	Description	Value
Emission	<p>The Short circuit/Overload status indication object is sent on the bus:</p> <p>On each change.</p> <p>Periodically after a configurable time.</p> <p>On change and periodically after a configurable time.</p>	<p>On status change</p> <p>Periodically</p> <p>On status change and periodically*</p>

Note: The object transmission conditions are valid for all the outputs.

Communication objects:

[6, 33, 60, 87, 114, 141](#) - **Output x - Short circuit/Overload status indication** (1 - Bit - 1.005 DPT_Alarm)

Parameter	Description	Value
Periodicity	This parameter determines the time between the individual transmission of the Short circuit/Overload status indication object.	00:00:01 ... 00:10:00* ... 23:59:59 (hh:mm:ss)

*Note: This parameter is only visible if the **Emission** parameter has the following value : **Periodically** or **On status change and periodically**.*

* Default value

** Only for TYMS646R

3.2 Output functionalities

3.2.1 Overall parameters

Output 1 name	<input type="text" value="Output 1"/>
Output 2 name	<input type="text" value="Output 2"/>
Output 3 name	<input type="text" value="Output 3"/>
Output 4 name	<input type="text" value="Output 4"/>
Output 5 name	<input type="text" value="Output 5"/>
Output 6 name	<input type="text" value="Output 6"/>
Load shedding priority	
<div style="border: 1px solid #ccc; padding: 5px;"> i Priority between outputs in case of load shedding only if no short circuit/overload detection </div>	
Outputs C1/C3/C5	<input type="text" value="Output 1 < Output 3 < Output 5"/>
Outputs C2/C4/C6	<input type="text" value="Output 2 < Output 4 < Output 6"/>

Parameter	Description	Value
Output x name	This free text field is used to assign a name to the output in question. The group objects Name field will automatically be updated after input.	Output x*

x = 1 to 6

■ Load shedding priority

If a short-term overconsumption is detected on one of the output groups (C1/C3/C5) or (C2/C4/C6), the product applies a load shedding cycle. The parameters below are used to define the order of priority of the outputs for load shedding.

Note: This priority between the outputs in case of load shedding is only valid if and only if no short circuit or overload has been detected.

Parameter	Description	Value
Outputs C1/C3/C5	This parameter defines the order of priority of the outputs (C1/C3/C5) for load shedding.	Output 1 < Output 3 < Output 5* Output 1 < Output 5 < Output 3 Output 3 < Output 1 < Output 5 Output 3 < Output 5 < Output 1 Output 5 < Output 1 < Output 3 Output 5 < Output 3 < Output 1

* Default value

** Only for TYMS646R

Parameter	Description	Value
Outputs C2/C4/C6	This parameter defines the order of priority of the outputs (C2/C4/C6) for load shedding.	Output 2 < Output 4 < Output 6* Output 2 < Output 6 < Output 4 Output 4 < Output 2 < Output 6 Output 4 < Output 6 < Output 2 Output 6 < Output 2 < Output 4 Output 6 < Output 4 < Output 2

3.2.2 General

Valve

Default valve status Normally closed Normally open

Behavior at reset

Status after bus power cut Value as emergency ▼

Behaviour after ETS download Specific command value ▼

Command value %

Hours counter

Hours counter Not active Active

Valve protection

Valve protection Not active Active

Lock-up

Lock-up Not active Active

This parameter window is used to set the device outputs. These parameters are available individually for each output.

* Default value

** Only for TYMS646R

3.2.2.1 Valve

Parameter	Description	Value
Default valve status	<p>There are 2 types of valves which can be connected to the outputs. The valves can be opened or closed when they are switched off. This parameter is used to configure the output thus determining the direction in which the valves are driven.</p> <p>The valves connected to the output are of the type:</p> <ul style="list-style-type: none"> - The valves are opened when they are switched off - The valves are closed when they are switched off 	<p>Normally open*</p> <p>Normally closed</p>

3.2.2.2 Behavior at reset

Parameter	Description	Value
Status during bus power cut	<p>In case of a bus power cut, this parameter is used to determine the behaviour of the valve control output.</p> <p>The output status remains unchanged during a bus power cut.</p> <p>The product positions the output according to a defined parameter value. This value is determined by the Command value parameter.</p> <p>The product positions the output according to a defined parameter value in priority mode.</p> <p>The product positions the output according to a defined parameter value in emergency mode.</p>	<p>Value before bus power cut</p> <p>Specific command value</p> <p>Value as priority</p> <p>Value as emergency*</p>

Parameter	Description	Value
Command value	This parameter defines the position of the valve in case of bus power cut.	0* ... 100%

*Note: This parameter is only visible when the **Status during bus power cut** parameter has the value: **Specific command value**.*

* Default value

** Only for TYMS646R

Parameter	Description	Value
Behaviour after ETS download	<p>This parameter is used to determine the behaviour of the valve control output after an ETS download.</p> <p>The output status remains unchanged after ETS download.</p> <p>The product positions the output according to a defined parameter value. This value is determined by the Command value parameter.</p> <p>The product positions the output according to a defined parameter value in priority mode.</p> <p>The product positions the output according to a defined parameter value in emergency mode.</p>	<p>Value before bus power cut</p> <p>Specific command value</p> <p>Value as priority</p> <p>Value as emergency*</p>

Parameter	Description	Value
Command value	This parameter defines the position of the valve after an ETS download.	0* ... 100%

Note: : This parameter is only visible when the **Behaviour after an ETS download** parameter has the value: **Predefine the parameter**.

3.2.2.3 Hours counter

Parameter	Description	Value
Hours counter	<p>The Hours counter tab and the associated parameters and objects are:</p> <p>Hidden.</p> <p>Displayed.</p>	<p>Not active*</p> <p>Active</p>

A telegram can be sent via the **Hours counter setpoint reached** object according to a configurable setpoint. It is also possible to reset the count value via a 1 signal on the **Reset hours counter value** object.

Communication objects:

[12, 39, 66, 93, 120, 147](#) - Output x - Hours counter value (h) (2 - Byte - 7.007 DPT_TimePeriodHrs)

[14, 41, 68, 95, 122, 149](#) - Output x - Reset hours counter value (1 - Bit - 1.015 DPT_Reset)

[15, 42, 69, 96, 123, 150](#) - Output x - Hours counter setpoint reached (1 - Bit - 1.011 DPT_State)

For configuration see section: [Hours counter](#).

* Default value

** Only for TYMS646R

3.2.2.4 Valve protection

Parameter	Description	Value
Valve protection	The Valve protection tab and all the parameters linked to the function are: Hidden. Displayed.	Yes* No

Communication objects:

[21, 48, 75, 102, 129, 156](#) - **Output x - Valve protection duration** (2 - Byte - 7.006 DPT_TimePeriodMin)
[22, 49, 76, 103, 130, 157](#) - **Output x - Valve protection periodicity** (2 - Byte - 7.007 DPT_TimePeriodHrs)

For configuration see section: [Valve protection](#).

3.2.2.5 Lock-up

Parameter	Description	Value
Lock-up	The Lock-up tab and the associated parameters and objects are: Hidden. Displayed.	Active* Not active

Parameter	Description	Value
Number of lock-up objects	The Lock-up tab and the associated parameters and objects are: Displayed for 1 lock-up object. Displayed for 2 lock-up objects.	1* 2

Communication objects Lock-up 1:

[24, 51, 78, 105, 132, 159](#) - **Output x - Lock-up 1** (1 - Bit - 1.003 DPT_Enable)

Communication objects Lock-up 2:

[25, 52, 79, 106, 133, 160](#) - **Output x - Lock-up 2** (1 - Bit - 1.003 DPT_Enable)

* Default value

** Only for TYMS646R

3.2.3 Function selection

Output accounted for pump control	<input type="radio"/> No <input checked="" type="radio"/> Yes
Output accounted for heating requirement	<input type="radio"/> No <input checked="" type="radio"/> Yes
Output accounted for largest command value	<input type="radio"/> No <input checked="" type="radio"/> Yes
Output accounted for service mode	<input type="radio"/> No <input checked="" type="radio"/> Yes
Output accounted for manual mode	<input type="radio"/> No <input checked="" type="radio"/> Yes
Heating activation status	<input type="radio"/> No <input checked="" type="radio"/> Yes

Parameter	Description	Value
Output accounted for pump control	<p>The pump control is a global function of the heating product. This parameter is used to define whether the valve output in question is taken into account in the pump control.</p> <p>The Pump control function does not take the output into account for evaluation of the control threshold.</p> <p>The Pump control function takes the output into account for evaluation of the control threshold.</p>	<p>No</p> <p>Yes*</p>

*Note: This parameter is only authorised when the **Pump control** parameter for the **Valves/pumps** tab in the product general menu has the value: **Yes**.*

Parameter	Description	Value
Output accounted for heating requirement	<p>The product itself can evaluate the parameters of its outputs and transmit a general heating requirement according to a monitoring limit value. This parameter is used to define whether the valve output in question is taken into account in the heat requirement.</p> <p>The Heat requirement function does not take the output into account for evaluation of the control threshold.</p> <p>The Heat requirement function takes the output into account for the evaluation of the control threshold.</p>	<p>No</p> <p>Yes*</p>

*Note: This menu is only authorised if the **Heat requirement** parameter of the **Valves/pumps** tab in the product general menu has the value: **Yes**.*

* Default value

** Only for TYMS646R

Parameter	Description	Value
Output accounted for largest command value	<p>Thanks to the evaluation of the largest command value in the heating or cooling system, the product makes it possible to influence the energy consumption of a building or house. This parameter is used to define whether the valve output in question is taken into account in the largest command value.</p> <p>The largest command value function does not take the output into account for the evaluation of the control threshold.</p> <p>The largest command value function takes the output into account for the evaluation of the control threshold.</p>	<p>No</p> <p>Yes*</p>

*Note: This parameter is only authorised if the **Largest command value** parameter for the **Valves/pumps** tab in the product general menu has the value: **Yes**.*

Parameter	Description	Value
Output accounted for service mode	<p>If the service mode is active, the outputs in question are in completely closed or open position, thus blocking any other control.</p> <p>This parameter is used to define whether the valve output in question is taken into account for the service mode.</p> <p>The service mode is not authorised on this valve output.</p> <p>The service mode is authorised on this valve output.</p>	<p>No</p> <p>Yes*</p>

*Note: This parameter is only authorised if the **Service mode** parameter in the **product General** tab has the value: **Yes**.*

Parameter	Description	Value
Output accounted for manual mode	<p>In this mode, the outputs are blocked in a configurable status. Manual mode is activated by the switch on the front of the device. This parameter is used to define whether the valve output in question is taken into account for manual mode.</p> <p>Manual mode is not authorised on this valve output.</p> <p>Manual mode is authorised on this valve output.</p>	<p>No</p> <p>Yes*</p>

*Note: This parameter is only authorised if the **Manual mode** parameter in the **product General** tab has the value: **Active** or **Time limited**.*

Parameter	Description	Value
Heating activation status	<p>The Heating activation object is used to control the activation and deactivation of all the valve output at the same time by the KNX bus.</p> <p>This parameter is used to define whether the valve output in question is taken into account for heating activation.</p> <p>Heating activation is not authorised on this valve output.</p> <p>Heating activation is authorised on this valve output.</p>	<p>No</p> <p>Yes*</p>

3.2.4 Control/Status/Operating mode

3.2.4.1 General

This parameter window is used to set the device outputs. These parameters are available individually for each output.

Command value format Continuous with PWM (1 byte) ▼

Cycle time for continuous control with PWM hh:mm:ss

Command value monitoring

Command value monitoring No Yes

Monitoring time hh:mm

Command value limitation

Command value limitation Not used ▼

Emergency mode

Command value when emergency active in summer %

Command value when emergency active in winter %

Priority position

Command value when priority active in summer %

Command value when priority active in winter %

Priority object format Not used ▼

Short circuit/Overload status indication

Short circuit/Overload status indication No Yes

The product receives information from the KNX bus in 1 bit or 1 byte format from a KNX room thermostat for example. In general, based on room temperature, the regulator determines the values to be sent to the output product. The latter controls its valve outputs according to the data configured in ETS.

The different formats of the control value for the valve outputs are:

■ ON/OFF (1 bit)

Valve output is controlled using an object in 1 bit format (ON/OFF). The value of the object depends on the **Default valve status** parameter.

Normally open:

On reception of an OFF control, the valve is powered and closes.

On reception of an ON control, the valve is not powered and opens.

Normally closed:

On reception of an OFF control, the valve is not powered and closes.

On reception of an ON control, the valve is powered and opens.

■ Continuous with PWM (1 byte)

The value of the valve output control is converted by the product into a pulse-width modulation switching signal. The behaviour of the output is constantly adapted according to the parameter received. The cycle time can also be configured using the **Cycle time for continuous control with PWM** parameter.

Taking into account the default valve status, the output is powered or not depending on the position the valve is to adopt.

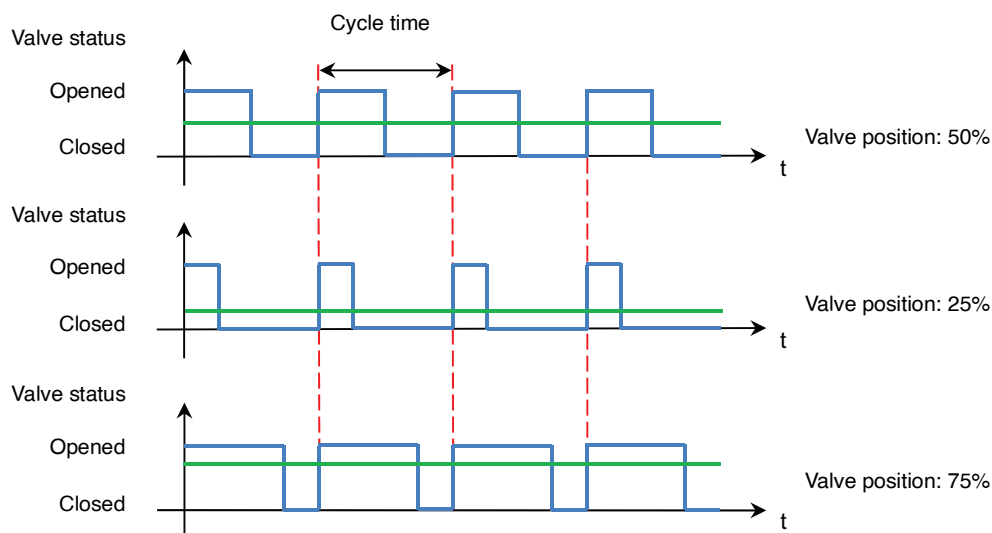

■ ON/OFF with command value (1 byte)

The constant control value received is converted into an output signal according to the configured limit value.

The actuator opens when the parameter reaches or exceeds the limit value. A hysteresis is also evaluated to avoid the constant closing and opening of the valve operating in the limit value zone. The actuator only closes when the command value reaches the limit value minus the hysteresis.

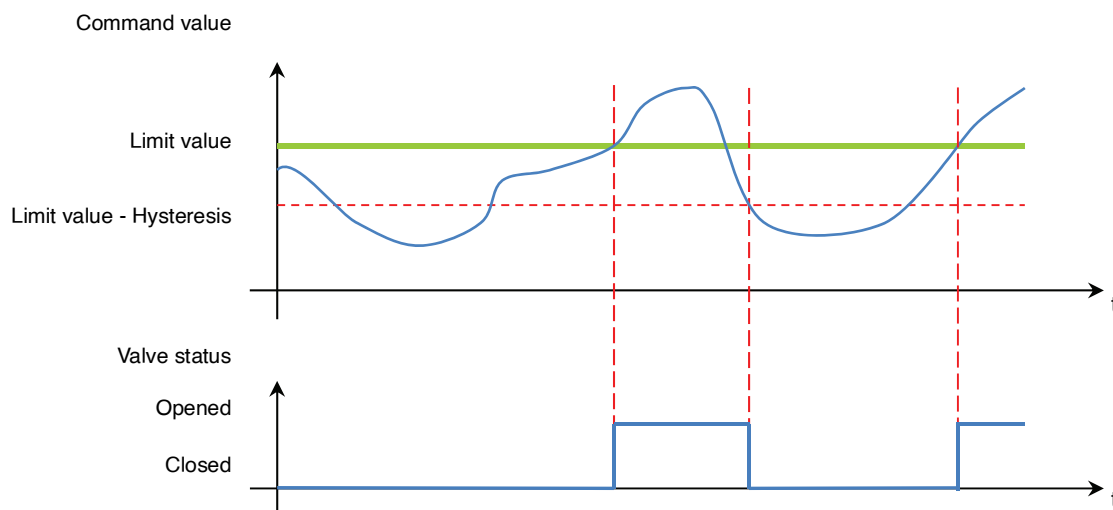

Parameter	Description	Value
Command value format	The valve output in question is controlled using an object in the format: 1 bit with an ON/OFF control 1 byte using a pulse-width modulation switching signal 1 byte with an ON/OFF control according to the limit value	ON/OFF (1 bit) Continuous with PWM (1 byte)* ON/OFF with command value (1 byte)

Parameter	Description	Value
Threshold value for valve opening/closing (0-100%)	This parameter defines the opening and closing threshold for the valve in question at the limit value.	0 ... 10* ... 100

*Note: This parameter is only visible when the **Command value format** parameter has the value **ON/OFF with command value (1 byte)**.*

Parameter	Description	Value
Hysteresis value for valve opening/closing (0-100%)	This parameter defines the hysteresis of the valve opening/closing threshold. Valve closure is only active when the value exceeds the limit value minus the hysteresis.	0 ... 5* ... 100

*Note: This parameter is only visible when the **Command value format** parameter has the value **ON/OFF with command value (1 byte)**.*

* Default value

** Only for TYMS646R

Parameter	Description	Value
Cycle time for continuous control with PWM	This parameter defines the switching frequency of the pulse-width modulation output signal of the valve output. It allows an adaptation of the operation of the different actuators having different cycle times (duration of movement between the valve's open and closed position).	00:00:01 ... 00:15:00* ... 12:00:00 (hh:mm:ss)

3.2.4.2 Command value monitoring

Parameter	Description	Value
Command value monitoring	As an option, command value monitoring can be authorised. If no order is received during the monitoring time, the Command value monitoring failure object is activated and emergency mode is activated for the valve output in question. The objects and the associated parameters are hidden. The objects and the associated parameters are displayed.	No Yes*

Note: Command value monitoring is valid for all the command value formats.

Parameter	Description	Value
Monitoring time	This parameter defines the maximum duration between 2 command values received.	00:01 ... 01:00* ... 23:59 (hh:mm)

Communication objects:

[5](#), [32](#), [59](#), [86](#), [113](#), [140](#) - **Output x - Command value monitoring failure (1 - Bit - 1.005 DPT_Alarm)**

3.2.4.3 Command value limitation

If the valve output is controlled by a **Continuous with PWM (1 byte)** control, a command value limitation may be used. Command value limitation makes it possible to limit command values received via the KNX bus or emergency operation controls, within a "minimum" and "maximum" value range.

A minimum command value can be used, for example to implement basic heating or cooling.

A maximum command value is used to limit the effective setpoint values, which generally has a positive influence on actuator lifetime.

Example: Minimum command value: 10% - Maximum command value: 80%

- For a command value received from 50%, the command value applied will be 50% (no limitation).
- For a command value received from 5%, the command value applied will be 10% (application of the minimum command value).
- For a command value received from 90%, the command value applied will be 80% (application of the maximum command value).

* Default value

** Only for TYMS646R

Parameter	Description	Value
Command value limitation	Use of command value limitation: Is not authorised. Is authorised with no restriction. is controlled using the Command value limitation activation object.	Not used* Always active Through object

*Note: This parameter is only visible when the **Command value format** parameter has the value **Continuous with PWM (1 byte)**.*

Parameter	Description	Value
Minimum command value	This parameter defines the minimum command value for limitation.	0* ... 100%

Parameter	Description	Value
Maximum command value	This parameter defines the maximum command value for limitation.	0 ... 100%*

- Command value limitation by object

Communication objects:

11, 38, 65, 92, 119, 146 - Output x - Command value limitation activation (1 - Bit - 1.003 DPT_Enable)

Parameter	Description	Value
Command value limitation at bus return	In case of control via the Command value limitation activation object, activation of command value limitation after bus power returns. During this operation, this parameter defines whether or not command value limitation is used. The use of command value limitation on bus return: Is not authorised. Is authorised.	No* Yes

*Note: This parameter is only visible when the **command value limitation** parameter has the value **Through object**.*

* Default value

** Only for TYMS646R

Parameter	Description	Value
Command value limitation after ETS download	In case of control via the Command value limitation activation object, activation of command value limitation after a ETS download. During this operation, this parameter defines whether or not command value limitation is used. The use of command value limitation after a ETS download: Is not authorised. Is authorised.	No* Yes

*Note: This parameter is only visible when the **command value limitation** parameter has the value **Through object**.*

3.2.4.4 Emergency mode

Emergency mode is used to position the valve output when a fault appears. This fault may be an incorrect command value or a KNX bus is not connected. This mode can also be used for the return of the bus power or mains power. Different parameter values can be configured for the summer and winter mode.

Parameter	Description	Value
Command value when emergency active	This parameter defines the command value when the output switches to emergency mode.	0 ... 30* ... 100%

*Note: This parameter is only visible if the **Summer/winter mode changeover** parameter has the value **No**.*

Parameter	Description	Value
Command value when emergency active in summer	This parameter defines the command value when the output switches to emergency mode for the summer.	0 ... 30* ... 100%

*Note: This parameter is only visible if the **Summer/winter mode changeover** parameter has the value **Yes**.*

Parameter	Description	Value
Command value when emergency active in winter	This parameter defines the command value when the output switches to emergency mode for the winter.	0 ... 70* ... 100%

*Note: This parameter is only visible if the **Summer/winter mode changeover** parameter has the value **Yes**.*

* Default value

** Only for TYMS646R

3.2.4.5 Priority position

Priority position is used to position the valve output when priority is active. The valve outputs in question are then locked so that they can no longer be controlled by other lower level functions. Priority is activated through objects in 1 or 2 bit format. Different parameter values can be configured for the summer and winter mode.

Parameter	Description	Value
Command value when priority active	This parameter defines the command value when priority is active for the valve output in question.	0 ... 30* ... 100%

*Note: This parameter is only visible if the **Summer/winter mode changeover** parameter has the value **No**.*

Parameter	Description	Value
Command value when priority active in summer	This parameter defines the command value when priority is active for the valve output in question for the summer.	0 ... 30* ... 100%

*Note: This parameter is only visible if the **Summer/winter mode changeover** parameter has the value **Yes**.*

Parameter	Description	Value
Command value when priority active in winter	This parameter defines the command value when priority is active for the valve output in question for the winter.	0 ... 70* ... 100%

*Note: This parameter is only visible if the **Summer/winter mode changeover** parameter has the value **Yes**.*

Parameter	Description	Value
Priority object format	The use of limitation of the Priority function: Is not authorised. Is authorised in 1 bit format. Is authorised in 2 bit format.	Not used* 1 bit 2 bit

* Default value

** Only for TYMS646R

■ 1 bit format

Parameter	Description	Value
Priority object polarity	<p>Upon reception of a value on the Priority object, priority:</p> <p>Is active with the value 1. The output is positioned according to the Command value when priority active parameter.</p> <p>Is inactive with the value 0. The output is positioned at the value present before priority was activated.</p> <p>Is inactive with the value 1. The output is positioned at the value present before priority was activated.</p> <p>Is active with the value 0. The output is positioned according to the Command value when priority active parameter.</p>	<p>1 = Priority active, 0 = Priority not active*</p> <p>1 = Priority not active, 0 = Priority active</p>

*Note: This parameter is only visible if the **Priority object format** parameter has the value **1 bit**.*

Communication objects:

8, 35, 62, 89, 116, 143 - Output x - Priority (1 Bit) (1 - Bit - 1.003 DPT_Enable)

■ 2 bit format

Communication objects:

7, 34, 61, 88, 115, 142 - Output x - Priority (2 - Bit - 2.002 DPT_Bool_Control)

Parameter	Description	Value
Status indication priority object	<p>The Status indication priority object is hidden.</p> <p>The Status indication priority object is hidden.</p>	<p>Not active*</p> <p>Active</p>

*Note: This object can be used if the **Priority object format** has the value **1 bit** or **2 bit**.*

Communication objects:

9, 36, 63, 90, 117, 144 - Output x - Status indication priority (1 - Bit - 1.003 DPT_Enable)

Parameter	Description	Value
Polarity	<p>The Priority mode status indication object sends:</p> <p>0 = on activation of the Priority 1 = on deactivation of the Priority</p> <p>0 = on deactivation of the Priority 1 = on activation of the Priority</p>	<p>0 = Priority active, 1 = Priority not active</p> <p>0 = Priority not active, 1 = Priority active*</p>

*Note: This parameter is only visible if the **Status indication priority object** parameter has the value **Active**.*

* Default value

** Only for TYMS646R

Parameter	Description	Value
Emission	<p>The Status indication priority communication object is sent:</p> <p>On activation and deactivation of the Priority. Periodically after a configurable time.</p> <p>On activation and deactivation of the Priority and periodically after a configurable time.</p>	<p>On status change*</p> <p>Periodically</p> <p>On status change and periodically</p>

*Note: This parameter is only visible if the **Status indication priority object** parameter has the value **Active**.*

Parameter	Description	Value
Periodicity	This parameter determines the time between the individual transmissions of the Status indication priority object.	00:00:01 ... 00:30:00* ... 23:59:59 (hh:mm:ss)

*Note: This parameter is only visible if the **Emission** parameter has the following value **Periodically** or **On status change and periodically**.*

3.2.4.6 Short circuit/Overload status indication

Parameter	Description	Value
Short circuit/Overload status indication	<p>The product monitors the power supply on the valves. In case of failure, a notification telegram can be sent.</p> <p>The short circuit/overload indication for the valve output is deactivated. The Short circuit/Overload status indication is hidden.</p> <p>The short circuit/overload indication for the valve output is activated. The Short circuit/Overload status indication is displayed.</p>	<p>No*</p> <p>Yes</p>

Communication objects:

[6, 33, 60, 87, 114, 141](#) - [Output x - Short circuit/Overload status indication \(1 - Bit - 1.005 DPT_Alarm\)](#)

* Default value

** Only for TYMS646R

3.2.5 Valve protection

To avoid a valve becoming clogged with limescale or seizing if it is not activated for a certain length of time, the product has an automatic valve protection function. Valve protection can be performed cyclically or via a communication object involving a full movement of the valve for a defined duration. The product continuously activates a value of 100% for the valve output in question for half the configured duration. The valve thus fully opens. When half the duration has passed, the product switches to a value of 0%, leading to the complete closure of the valve.

Valve protection activation	Periodically
Periodicity	Every week
Valve protection duration	10 Minutes
Smart valve protection	<input type="radio"/> No <input checked="" type="radio"/> Yes
Valve protection minimum commande value	80 %

Parameter	Description	Value
Valve protection activation	<p>Activation of valve protection is triggered.</p> <p>Periodically according to a configurable cycle duration.</p> <p>Periodically according to a configurable cycle duration and with a defined date and time of first activation.</p> <p>Using the Valve protection start/stop object</p>	<p>Periodically*</p> <p>Periodically starting at a specified date/time</p> <p>Through object</p>

Note: Valve protection stops after a configurable period or using the **Valve protection start/stop** object.

■ Periodically

Parameter	Description	Value
Periodicity	This parameter determines the time between each valve protection activation.	<p>Every day</p> <p>Every week*</p> <p>Every 3 weeks</p> <p>Every month</p> <p>Every 2 months</p> <p>Every 3 months</p> <p>Every 6 months</p> <p>Every year</p>

Note: This parameter is only visible if the **Valve protection activation** parameter has the value **Periodically** or **Periodically starting at a specified date/time**.

* Default value

** Only for TYMS646R

Communication objects:

- [21, 48, 75, 102, 129, 156](#) - Output x - Valve protection duration (2 - Byte - 7.006 DPT_TimePeriodMin)
- [22, 49, 76, 103, 130, 157](#) - Output x - Valve protection periodicity (2 - Byte - 7.007 DPT_TimePeriodHrs)

■ Periodically starting at a specified date/time

Parameter	Description	Value
Periodicity	This parameter determines the time between each valve protection activation.	Every day Every week* Every 3 weeks Every month Every 2 months Every 3 months Every 6 months Every year

*Note: This parameter is only visible if the **Valve protection activation** parameter has the value **Periodically** or **Periodically starting at a specified date/time**.*

Parameter	Description	Value
Year	This parameter defines the date and time of first activation of valve protection.	0 ... 1972* ... 4095
Month		January ... March* ... December
Day of the month		1 ... 13* ... 31
Time of first activation		00:00:00* ... 23:59:59 (hh:mm:ss)

Communication objects:

- [18, 45, 72, 99, 126, 153](#) - Output x - Valve protection date (3 - Byte - 11.001 DPT_Date)
- [19, 46, 73, 100, 127, 154](#) - Output x - Valve protection time (3 - Byte - 10.001 DPT_TimeOfDay)
- [20, 47, 74, 101, 128, 154](#) - Output x - Date and time of valve protection (8 - Byte - 19.001 DPT_DateTime)

■ Through object

Pump protection is carried out using an external device by the KNX bus.

Parameter	Description	Value
Polarity	The Valve protection start/stop object receives: 1 = Valve protection starts 0 = Valve protection stops 1 = Valve protection stops 0 = Valve protection starts	1 = Start, 0 = Stop* 1 = Stop, 0 = Start

*Note: This parameter is only visible if the **Valve protection activation** parameter has the value **Through object**.
Note: Valve protection stops after a configurable period or using the **Valve protection start/stop** object.*

Communication objects:

- [23, 50, 77, 104, 131, 158](#) - Output x - Valve protection start/stop (1 - Bit - 1.010 DPT_Start)

* Default value

** Only for TYMS646R

■ Valve protection duration

Parameter	Description	Value
Valve protection duration	This parameter defines valve protection operating time. Valve protection can be stopped before the end of this duration using the Valve protection start/stop object.	1 ... 5* ... 59 min

This duration can also be modified using the following object:

Communication objects:

[21, 48, 75, 102, 129, 156](#) - Output x - Valve protection duration (2 - Byte - 7.006 DPT_TimePeriodMin)

■ Smart valve protection

This function is used to activate valve protection, taking into account the number of activations and the operating time of the valve.

Example: Valve protection activation periodicity: Every week

Valve protection duration: 5 minutes

When smart valve protection is activated, valve protection is activated if the pump has not been activated for more than 5 minutes over a period of one week.

Parameter	Description	Value
Smart valve protection	The smart pump protection function is deactivated.	No
	The smart pump protection function is activated.	Yes*

Parameter	Description	Value
Valve protection minimum command value	This parameter defines the valve protection minimum command value. Smart valve protection is then only carried out on a regular basis if the minimum parameter limit value configured at this point is not exceeded.	0 ... 80* ... 100%

*Note: This parameter is only visible if the **Smart valve protection** parameter has the value **Yes**.*

* Default value

** Only for TYMS646R

3.2.6 Hours counter

The Hours counter function is used to count the overall activation time of an output. An output is activated when it is energised and the status LED on the front of the device is on. The operating hours counter setpoint can be programmed and altered via an object.

i Activate the parameter "Restore ETS-params settings" in General / General so that the parameter value is taken into account after next download.

Hours counter direction Increment Countdown

Hours counter setpoint h

Counter setpoint value modifiable through object Not active Active

Hours counter objects unit Hours Seconds

Hours counter Emission

Periodical emission delay hh:mm:ss

Hours counter setpoint reached Emission

Periodical emission delay hh:mm:ss

Parameter	Description	Value
Hours counter direction	The hours counter counts: Growing. Decreasing.	Increment* Countdown

Increment:

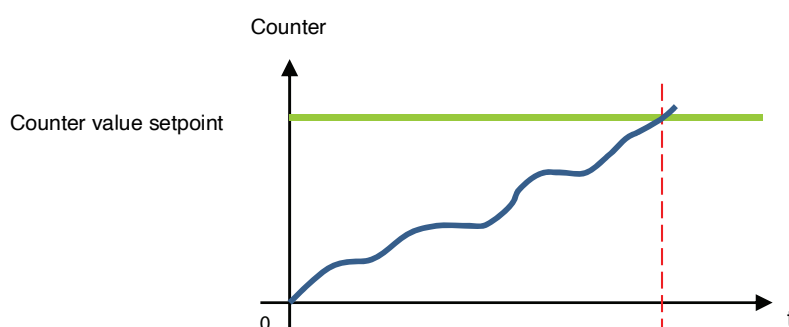

The counter starts to count up from the value 0. As soon as the counter setpoint (**Hours counter setpoint** object) is reached, the **Hours counter setpoint reached** object is set to 1 and sent to the bus.

* Default value

** Only for TYMS646R

Countdown:

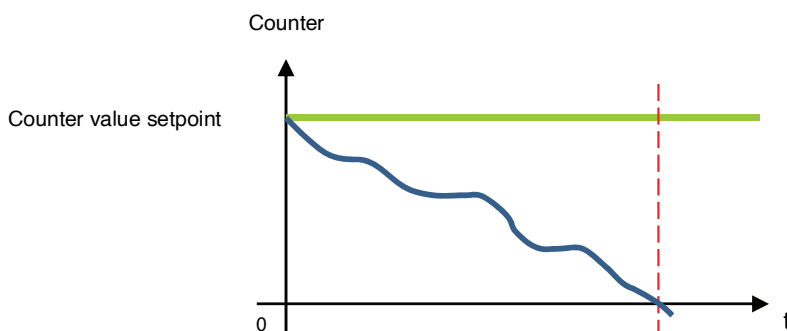

The counter starts to count down from the operating hours counter setpoint (**Hours counter setpoint** object). As soon as the counter reaches 0, the **Hours counter setpoint reached** is set to 1 and sent to the bus.

Parameter	Description	Value
Hours counter setpoint	This parameter determines the value of the hours counter.	1 ... 65535* ... 1193046 (Hours)

An incrementing counter starts at 0 and counts up until it reaches the setpoint value.

A countdown counter starts to count at the setpoint value and counts down until it has arrived at 0.

Parameter	Description	Value
Counter setpoint value modifiable through object	The Hours counter setpoint communication object is hidden.	Not active*
	The Hours counter setpoint communication object is displayed. The value can be changed via the KNX bus.	Active

Parameter	Description	Value
Hours counter objects unit	Operating hours are counted in:	
	Hours Seconds	Hours Seconds*

Communication objects:

16, 43, 70 97, 124, 151 - Output x - Hours counter setpoint (h) (2 - Byte - 7.007 DPT_TimePeriodHrs)

17, 44, 71, 98, 125, 152 - Output x - Hours counter setpoint (s) (4 - Byte - 13.100 DPT_LongDeltaTimeSec)

* Default value

** Only for TYMS646R

■ Hours counter

Parameter	Description	Value
Emission	The Hours counter value communication object is sent: On each change. Periodically after a configurable time. On change and periodically after a configurable time.	On status change Periodically* On status change and periodically

Parameter	Description	Value
Value interval	This parameter defines the value of the interval (in seconds or hours) of the frequency at which the Hours counter setpoint object is sent.	1 ... 1800* ... 65535 (Seconds) or 1* ... 65535 (Hours)

*Note: The value interval unit depends on the **Hours counter objects unit** parameter.*

*Note: If the value interval is 200 hours, then the **Hours counter setpoint** object is sent each time the Operating h. counter value is increased by 200 hours.*

*Note: This parameter is only visible if the **Emission hours counter value** parameter has the following value **Periodically** or **On status change and periodically**.*

Parameter	Description	Value
Periodical emission delay	This parameter determines the time between the individual transmissions of the Hours counter setpoint object.	00:00:01 ... 00:30:00* ... 23:59:59 (hh:mm:ss)

*Note: This parameter is only visible if the **Emission hours counter value** parameter has the following value **Periodically** or **On status change and periodically**.*

■ Hours counter setpoint reached

Parameter	Description	Value
Emission	The Hours counter setpoint reached communication object is sent: On reaching the counter setpoint. Periodically after a configurable time. On reaching the counter setpoint and periodically after a configurable time.	On status change Periodically On status change and periodically*

* Default value

** Only for TYMS646R

Parameter	Description	Value
Periodical emission delay	This parameter determines the time between the individual transmissions of the Hours counter setpoint reached object.	00:00:01 ... 00:30:00* ... 23:59:59 (hh:mm:ss)

*Note: This parameter is only visible if the Object **Emission counter setpoint reached** parameter has the following value **Periodically** or **On status change and periodically**.*

3.2.7 Lock-up

This parameter window is used to set the device outputs. These parameters are available individually for each output.

Lock-up duration	<input type="radio"/> Time limited <input checked="" type="radio"/> Permanently
Polarity of lock-up object 1	<input checked="" type="radio"/> 0 = Lock-up deactivated, 1 = Lock-up activated <input type="radio"/> 0 = Lock-up activated, 1 = Lock-up deactivated
Polarity of lock-up object 2	<input checked="" type="radio"/> 0 = Lock-up deactivated, 1 = Lock-up activated <input type="radio"/> 0 = Lock-up activated, 1 = Lock-up deactivated
Priority between lock-up 1 and lock-up 2	Lock-up 1 > Lock-up 2 ▼
Status if lock-up 1	<input type="radio"/> Value (0-100%) <input checked="" type="radio"/> Maintain status
Status if lock-up 2	<input checked="" type="radio"/> Value (0-100%) <input type="radio"/> Maintain status
Lock-up value	100 %
Status after lock-up function 1	Maintain status ▼
Status after lock-up function 2	Maintain status ▼
Activation of lock-up status object	<input type="radio"/> Not active <input checked="" type="radio"/> Active
Polarity	<input checked="" type="radio"/> 0 = Lock-up deactivated, 1 = Lock-up activated <input type="radio"/> 0 = Lock-up activated, 1 = Lock-up deactivated
Emission	On status change and periodically ▼
Emission period	00:10:00 hh:mm:ss

The Lock-up function is used to lock the output in a predefined state. The Lock-up prevents actuation until an unlock command has been received. The Lock-up duration can be set.

Parameter	Description	Value
Lock-up duration	<p>The duration of the Lock-up is.</p> <p>Not time limited, the lock-up is only authorized by means of a telegram on Lock-up 1 object.</p> <p>Is active for a limited time, the control of the output is authorized after expiry of this time.</p>	<p>Permanently*</p> <p>Time limited</p>

Parameter	Description	Value
Duration	This parameter determines the activation time of the Lock-up.	00:01 ... 00:15* ... 99:59 (hh:mm)

Note: This parameter is only visible if the **Lock-up duration** parameter has the following value **Time limited**.

Parameter	Description	Value
Polarity of lock-up object 1	<p>On receipt of a value on the Lock-up 1 object, the lock-up:</p> <p>Is deactivated on object value 0. Is activated on object value 1.</p> <p>Is activated on object value 0. Is deactivated on object value 1.</p>	<p>0 = Lock-up deactivated, 1 = Lock-up activated*</p> <p>0 = Lock-up activated, 1 = Lock-up deactivated</p>

Note: The parameters and objects are identical for Lock-up 2. Only the terms will be adjusted.

Parameter	Description	Value
Priority between lock-up 1 and lock-up 2	<p>The priority between lock-up 1 and lock-up 2 is set as follows:</p> <p>Lock-up 1 has priority over lock-up 2.</p> <p>Lock-up 2 has priority over lock-up 1.</p> <p>Lock-up 1 and lock-up 2 have the same priority.</p>	<p>Lock-up 1 > Lock-up 2*</p> <p>Lock-up 1 < Lock-up 2</p> <p>Lock-up 1 = Lock-up 2</p>

Note: This parameter is only visible if the **Lock-up** parameter has the following value **Active with 2 lock-up objects**.

Operating principle of the priorities:

If Lock-up 1 > Lock-up 2

Active lock-up	Activation order of Lock-up 1	Activation order of Lock-up 2
None	Lock-up 1 is activated	Lock-up 2 is activated
Lock-up 1	Lock-up 1 remains active	Despite the activation order of Lock-up 2, Lock-up 1 remains activated
Lock-up 2	Lock-up 1 is activated	Lock-up 2 remains active

* Default value

** Only for TYMS646R

If Lock-up 1 = Lock-up 2

Active lock-up	Activation order of Lock-up 1	Activation order of Lock-up 2
None	Lock-up 1 is activated	Lock-up 2 is activated
Lock-up 1	Lock-up 1 remains active	Lock-up 2 is activated
Lock-up 2	Lock-up 1 is activated	Lock-up 2 remains active

If Lock-up 1 < Lock-up 2

Active lock-up	Activation order of Lock-up 1	Activation order of Lock-up 2
None	Lock-up 1 is activated	Lock-up 2 is activated
Lock-up 1	Lock-up 1 remains active	Lock-up 2 is activated
Lock-up 2	Despite the activation order of Lock-up 1, Lock-up 2 remains activated	Lock-up 2 remains active

Parameter	Description	Value
Status if lock-up 1	When lock-up is activated, the output: Not changed. Varies according to the position of the valve entered.	Maintain status* Value %

Parameter	Description	Value
Lock-up value	This parameter defines the value of the valve position during lock-up.	0 ... 100%*

*Note: This parameter is only visible if the **Status if lock-up 1** parameter has the value **Value %**.*

Note: The parameters and objects are identical for Lock-up 2. Only the terms will be adjusted.

Parameter	Description	Value
Status after lock-up function 1	When lock-up is deactivated, the output: Not changed. Return to the status that was active before the lock-up. Is positioned in the status which would be active if no lock-up control had taken place, taking into account the other active communication objects.	Maintain status* Status before lock-up 1 Theoretical status without lock-up function 1

Note: The application of this parameter depends on the priority of the other active functions. If a function with higher priority is active, this parameter will not be enacted. In the case where two functions with the same priority are active, the parameter of the most recently switched off function is enacted.

Note: The parameters and objects are identical for Lock-up 2. Only the terms will be adjusted.

* Default value

Parameter	Description	Value
Activation of lock-up status object	The Status indication lock-up communication object is hidden.	Not active*
	The Status indication lock-up communication object is displayed.	Active

Communication objects:

26, 53, 80, 107, 134, 161 - Output x - Status indication lock-up (1 - Bit - 1.003 DPT_Enable)

Parameter	Description	Value
Polarity	The Status indication Lock-up communication object sends: 0 on deactivation of the lock-up. 1 on activation of the lock-up	0 = Lock-up deactivated, 1 = Lock-up activated*
	0 on activation of the lock-up 1 on deactivation of the lock-up.	0 = Lock-up activated, 1 = Lock-up deactivated

Parameter	Description	Value
Emission	The Status indication lock-up communication object is sent: On activation and deactivation of the lock-up. Periodically after a configurable time.	On status change* Periodically
	On activation and deactivation of the lock-up and periodically after a configurable time.	On status change and periodically

*Note: This parameter is only visible if the **Activation of Lock-up status object** parameter has the following value **Active**.*

Parameter	Description	Value
Periodicity	This parameter determines the time between the individual transmissions of the Status indication lock-up object.	00:00:01 ... 00:10:00* ... 23:59:59 (hh:mm:ss)

Note: The smallest executable time is 1 second.

*Note: This parameter is only visible if the **Emission** parameter has the following value **Periodically** or **On status change and periodically**.*

3.3 Thermostat functions

This chapter is only valid for reference TYMS646R.

The following chapter describes the settings for the thermostat functions. This is where the parameters of the heating system (fancoil, underfloor heating, etc.) and the temperature values requested for the heating and/or cooling are configured.

3.3.1 Thermostats naming

Thermostat 1 name	<input type="text" value="Thermostat 1"/>
Thermostat 2 name	<input type="text" value="Thermostat 2"/>
Thermostat 3 name	<input type="text" value="Thermostat 3"/>
Thermostat 4 name	<input type="text" value="Thermostat 4"/>
Thermostat 5 name	<input type="text" value="Thermostat 5"/>
Thermostat 6 name	<input type="text" value="Thermostat 6"/>
Thermostat 7 name	<input type="text" value="Thermostat 7"/>
Thermostat 8 name	<input type="text" value="Thermostat 8"/>
Thermostat 9 name	<input type="text" value="Thermostat 9"/>
Thermostat 10 name	<input type="text" value="Thermostat 10"/>
Thermostat 11 name	<input type="text" value="Thermostat 11"/>
Thermostat 12 name	<input type="text" value="Thermostat 12"/>

Parameter	Description	Value
Thermostat name	This free text field is used to assign a name to the regulator in question. The group objects Name field will automatically be updated after input.	Thermostat x*

X = 1 to 12

* Default value

3.3.2 General

This configuration window is used to adjust the settings of the product thermostats. These parameters are available for each thermostat individually.

Function selection	Basic and additional heating and cooling
Ventilation available	<input type="checkbox"/>
Emission valve position heating and cooling to one common object	<input checked="" type="checkbox"/>
Status after reset	Status before reset
<hr/>	
Mode selection	Through value (1 byte)
<hr/>	
Heating/Cooling - changeover	<input type="radio"/> Automatic <input checked="" type="radio"/> Through object
Heat/cool mode after reset	Operating mode before reset
<hr/>	
Thermostat deactivation	<input type="radio"/> Through object <input checked="" type="radio"/> No
Lock-up additional step	<input type="radio"/> Through object <input checked="" type="radio"/> No
<hr/>	
Valve protection	Heating/Cooling
<div style="border: 1px solid #0070C0; padding: 5px; background-color: #E6F2FF;"> <p>i Activate the parameter "Restore ETS-params settings" in General / General so that the parameter value is taken into account after next download.</p> </div>	
Valve protection activation	Periodically
Periodicity	Every week
Valve protection duration	10 Minutes
Smart valve protection	<input type="radio"/> No <input checked="" type="radio"/> Yes
Valve protection minimum commande value	80 %
<hr/>	
Presence detection	<input checked="" type="checkbox"/>
Comfort lengthening time	00:30 hh:mm

3.3.2.1 Operation

The room thermostat mainly offers 2 operating modes: Heating and cooling modes. It is also possible to activate a mixed mode and a mode with 2 regulation levels.

The following diagram illustrates the 6 selection modes.

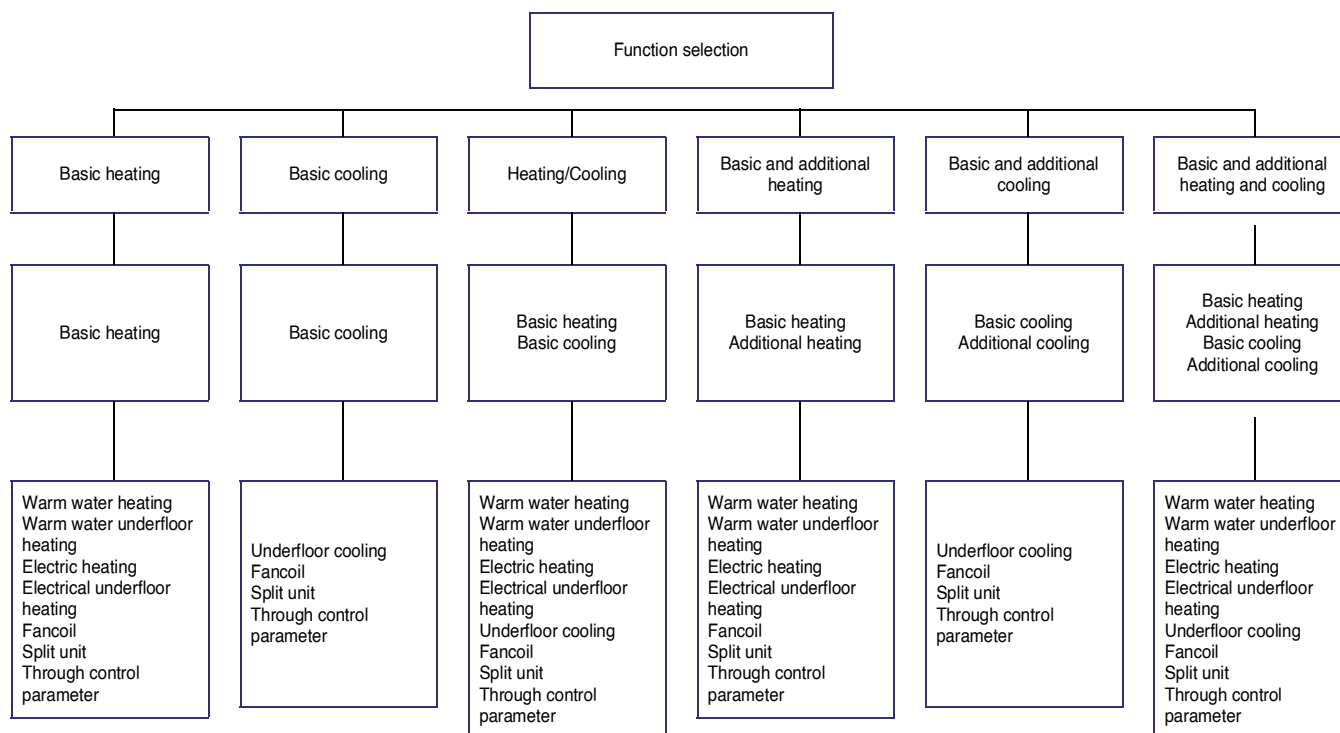

Parameter	Description	Value
Function selection	The product operates in the following mode: Heating Cooling Mixed Heating with 2 regulation levels Cooling with 2 regulation levels Mixed with 2 regulation levels	Heating* Cooling Heating/Cooling Basic and additional heating Basic and additional cooling Basic and additional heating and cooling

Parameter	Description	Value
Ventilation available	The Ventilation tab and all the parameters linked to the function are: Hidden. Displayed.	No* Yes

For configuration see section: [Ventilation](#).

* Default value

Parameter	Description	Value
Emission valve position heating and cooling to one common object	<p>This function is used when the same system is implemented in the room in summer to cool it and in winter to heat it. This parameter is used to display or hide the communication objects for the valve position.</p> <p>The valve is controlled using the same Valve position in % object for heating and cooling.</p> <p>The valve is controlled using 2 separate objects Valve position in % - Heating and Valve position in % - Cooling.</p>	<p>Yes*</p> <p>No</p>

*Note: This parameter is only visible if the **Function selection** parameter has the value **Heating/Cooling** or **Basic and additional heating and cooling**.*

Parameter	Description	Value
Status after reset	<p>If the product is reset, this parameter is used to determine the setpoint to take into account upon restart.</p> <p>Upon restart, the thermostat will have the setpoint</p> <p>Comfort</p> <p>Standby</p> <p>Night setpoint</p> <p>Frost/heat protection</p> <p>Present before the reset</p>	<p>Comfort</p> <p>Standby</p> <p>Night setpoint</p> <p>Frost/heat protection</p> <p>Status before reset*</p>

Parameter	Description	Value
Mode selection	<p>The heating or cooling mode is selected using:</p> <p>A single communication object in 1 byte format</p> <p>4 communication objects each in 1 bit format</p> <p>A single communication object in 1 byte format and/or 4 communication objects each in 1 bit format</p>	<p>Through value (1 byte)*</p> <p>Through switching (4x1 bit)</p> <p>Through value (1 byte) and/or through switching (4x bit)</p>

* Default value

■ Through value (1 byte)

Communication objects:

183, 282, 381, 480, 579, 678, 777, 876, 975, 1074, 1173, 1272 - Thermostat x - Setpoint selection (1 - Byte - 20.102 DPT_HVACMode)

■ Through switching (4x bit)

Communication objects:

184, 283, 382, 481, 580, 679, 778, 877, 976, 1075, 1174, 1273 - Thermostat x - Comfort (1 - Bit - 1.001 DPT_Switch)

185, 284, 383, 482, 581, 680, 779, 878, 977, 1076, 1175, 1274 - Thermostat x - Standby mode (1 - Bit - 1.001 DPT_Switch)

186, 285, 384, 483, 582, 681, 780, 879, 978, 1077, 1176, 1275 - Thermostat x - Night setpoint (1 - Bit - 1.001 DPT_Switch)

187, 286, 385, 484, 583, 682, 781, 880, 979, 1078, 1177, 1276 - Thermostat x - Frost/heat protection (1 - Bit - 1.001 DPT_Switch)

Parameter	Description	Value
Heating/Cooling - changeover	Mixed operation allows switching between Heating and Cooling. The changeover is made automatically according to the operating mode and the room temperature. The changeover is made exclusively via the Heating/Cooling - changeover object.	Automatic Through object*

*Note: This parameter is only visible if the **Function selection** parameter has the value **Heating/Cooling** or **Basic and additional heating and cooling**.*

Communication objects:

190, 289, 388, 487, 586, 685, 784, 883, 982, 1081, 1180, 1279 - Thermostat x - Heating/Cooling - changeover (1 - Bit - 1.001 DPT_Heat_Cool)

Parameter	Description	Value
Heat/cool mode after reset	If the product is reset, this parameter is used to determine the operating mode to be taken into account upon restart. Upon restart, the thermostat will be in the following mode: Heating Cooling Present before the reset	Heating Cooling Operating mode before reset*

*Note: This parameter is only visible if the **Function selection** parameter has the value **Heating/Cooling** or **Basic and additional heating and cooling**.*

* Default value

3.3.2.2 Thermostat deactivation

Thermostat deactivation	<input checked="" type="radio"/> Through object <input type="radio"/> No
Status during deactivation	<input checked="" type="radio"/> Frost/heat protection <input type="radio"/> OFF
Polarity	<input type="radio"/> ON = 0 <input checked="" type="radio"/> ON = 1
Heating deactivation polarity	<input type="radio"/> ON = 0 <input checked="" type="radio"/> ON = 1
Cooling deactivation polarity	<input type="radio"/> ON = 0 <input checked="" type="radio"/> ON = 1
Lock-up additional step	<input type="radio"/> Through object <input checked="" type="radio"/> No

Parameter	Description	Value
Thermostat deactivation	This parameter is used to suspend temperature regulation via an object. Depending on the operating mode, several objects are available. The objects and the associated parameters are hidden. The objects and the associated parameters are displayed.	No* Through object

The available communication objects are:

For all operating modes

[264, 363, 462, 561, 660, 759, 858, 957, 1056, 1155, 1254, 1353](#) - Thermostat x - Thermostat deactivation (1 - Bit - 1.003 DPT_Enable)

[265, 364, 463, 562, 661, 760, 859, 958, 1057, 1156, 1255, 1354](#) - Thermostat x - Status indication thermostat deactivation (1 - Bit - 1.003 DPT_Enable)

For **Heating/Cooling** and **Basic and additional heating and cooling**

[264, 363, 462, 561, 660, 759, 858, 957, 1056, 1155, 1254, 1353](#) - Thermostat x - Thermostat deactivation (1 - Bit - 1.003 DPT_Enable)

[265, 364, 463, 562, 661, 760, 859, 958, 1057, 1156, 1255, 1354](#) - Thermostat x - Status indication thermostat deactivation (1 - Bit - 1.003 DPT_Enable)

[260, 359, 458, 557, 656, 755, 854, 953, 1052, 1151, 1250, 1349](#) - Thermostat x - Heating deactivation (1 - Bit - 1.003 DPT_Enable)

[262, 361, 460, 559, 658, 757, 856, 955, 1054, 1153, 1252, 1351](#) - Thermostat x - Heating deactivation status (1 - Bit - 1.003 DPT_Enable)

[261, 360, 459, 558, 657, 756, 855, 954, 1053, 1152, 1251, 1350](#) - Thermostat x - Cooling deactivation (1 - Bit - 1.003 DPT_Enable)

[263, 362, 461, 560, 659, 758, 857, 956, 1055, 1154, 1253, 1352](#) - Thermostat x - Cooling deactivation status (1 - Bit - 1.003 DPT_Enable)

* Default value

Parameter	Description	Value
Status during deactivation	<p>This parameter is used to define the thermostat status on deactivation.</p> <p>On deactivation of the thermostat:</p> <p>Switches to Frost protection/Heat protection mode. Nevertheless, the thermostat is not completely deactivated.</p> <p>Switches to Frost protection/Heat protection mode and positions its output to OFF. The thermostat is completely deactivated.</p>	<p>Frost/heat protection*</p> <p>OFF</p>

*Note: This parameter is only visible if the **Thermostat deactivation** parameter has the value: **Through object**.*

Parameter	Description	Value
Polarity	<p>The Thermostat deactivation object receives:</p> <p>1 = The thermostat is active 0 = The thermostat is inactive</p> <p>1 = The thermostat is inactive 0 = The thermostat is active</p>	<p>ON = 0</p> <p>ON = 1*</p>

When the chosen operating mode is **Heating/Cooling** or **Basic and additional heating and cooling**, additional parameters are available to adjust the heating and cooling deactivation polarity. The principle is identical to that for the thermostat deactivation polarity.

Parameter	Description	Value
Lock-up additional step	<p>In two-level heating or cooling mode (basic and additional), the additional level can be locked up separately.</p> <p>The Lock-up additional step object is:</p> <p>Hidden.</p> <p>Displayed.</p>	<p>No*</p> <p>Through object</p>

*Note: This parameter is only visible if the **Function selection** parameter has the value **Basic and additional heating** or **Basic and additional cooling** or **basic and additional heating and cooling**.*

Parameter	Description	Value
Polarity	<p>The Lock-up additional step receives:</p> <p>0 = Lock-up is active 1 = Lock-up is inactive</p> <p>0 = Lock-up is inactive 1 = Lock-up is active</p>	<p>ON = 0</p> <p>ON = 1*</p>

* Default value

3.3.2.3 Valve protection

To avoid a valve becoming clogged with limescale or seizing if it is not activated for a certain length of time, the product has an automatic valve protection function. Valve protection can be performed cyclically or via a communication object involving a full movement of the valve for a defined duration. The product continuously activates a value of 100% for the valve output in question for half the configured duration. The valve thus fully opens. When half the duration has passed, the product switches to a value of 0%, leading to the complete closure of the valve.

Valve protection Heating/Cooling ▼

i Activate the parameter "Restore ETS-params settings" in General / General so that the parameter value is taken into account after next download.

Valve protection activation Periodically ▼

Periodicity Every week ▼

Valve protection duration 10 Minutes

Smart valve protection No Yes

Valve protection minimum commande value 80 %

Parameter	Description	Value
Valve protection	The Valve protection tab and all the paramters linked to the function are: Displayed. Hidden.	Yes* No

When the chosen operating mode is Heating/Cooling or Basic and additional heating and cooling, additional parameters are available to determine if valve protection should be used in heating mode or cooling mode or both.

Communication objects:

[279, 378, 477, 576, 675, 774, 873, 972, 1071, 1170, 1269, 1368](#) - Thermostat x - Valve protection duration (2 - Byte - 7.006 DPT_TimePeriodMin)

[280, 379, 478, 577, 676, 775, 874, 973, 1072, 1171, 1270, 1369](#) - Thermostat x - Valve protection periodicity (2 - Byte - 7.007 DPT_TimePeriodHrs)

* Default value

Parameter	Description	Value
Valve protection activation	Activation of valve protection is triggered: Periodically according to a configurable cycle duration. Periodically according to a configurable cycle duration and with a defined date and time of first activation. Using the Valve protection start/stop object	Periodically* Periodically starting at a specified date/time Through object

*Note: Valve protection stops after a configurable period or using the **Valve protection start/stop** object.*

■ Periodically

Parameter	Description	Value
Periodicity	This parameter determines the time between each valve protection activation.	Every day Every week* Every 3 weeks Every month Every 2 months Every 3 months Every 6 months Every year

*Note: This parameter is only visible if the **Valve protection activation** parameter has the value **Periodically** or **Periodically starting at a specified date/time**.*

Communication objects:

[279, 378, 477, 576, 675, 774, 873, 972, 1071, 1170, 1269, 1368](#) - Thermostat x - Valve protection duration (2 - Byte - 7.006 DPT_TimePeriodMin)

[280, 379, 478, 577, 676, 775, 874, 973, 1072, 1171, 1270, 1369](#) - Thermostat x - Valve protection periodicity (2 - Byte - 7.007 DPT_TimePeriodHrs)

■ Periodically starting at a specified date/time

Parameter	Description	Value
Periodicity	This parameter determines the time between each valve protection activation.	Every day Every week* Every 3 weeks Every month Every 2 months Every 3 months Every 6 months Every year

*Note: This parameter is only visible if the **Valve protection activation** parameter has the value **Periodically** or **Periodically starting at a specified date/time**.*

* Default value

Parameter	Description	Value
Year	This parameter defines the date and time of first activation of valve protection.	0 ... 1972* ... 4095
Month		January ... March* ... December
Day of the month		1 ... 13* ... 31
Time of first activation		00:00:00* ... 23:59:59 (hh:mm:ss)

Communication objects:

[276, 375, 474, 573, 672, 771, 870, 969, 1068, 1167, 1266, 1365](#) - Thermostat x - Valve protection date (3 - Byte - 11.001 DPT_Date)

[277, 376, 475, 574, 673, 772, 871, 970, 1069, 1168,](#) - Thermostat x - Valve protection time (3 - Byte - 10.001 DPT_TimeOfDay)

[278, 377, 476, 575, 674, 773, 872, 971, 1070, 1169, 1268, 1367](#) - Thermostat x - Date and time of valve protection (8 - Byte - 19.001 DPT_DateTime)

■ Through object

Pump protection is carried out using an external device by the KNX bus.

Parameter	Description	Value
Polarity	The Valve protection start/stop object receives: 1 = Valve protection starts. 0 = Valve protection stops. 1 = Valve protection stops. 0 = Valve protection starts.	1 = Start, 0 = Stop* 1 = Stop, 0 = Start

Note: : This parameter is only visible if the **Valve protection activation** parameter has the value **Through object**.

Note: Valve protection stops after a configurable period or using the **Valve protection start/stop** object.

Communication objects:

[281, 380, 479, 578, 677, 776, 875, 974, 1073, 1172, 1271, 1370](#) - Thermostat x - Valve protection start/stop (1 - Bit - 1.010 DPT_Start)

* Default value

■ Valve protection duration

Parameter	Description	Value
Valve protection duration	This parameter defines valve protection operating time. Valve protection can be stopped before the end of this duration using the Valve protection start/stop object.	1 ... 10* ... 59 min

This duration can also be modified using the following object:

Communication objects:

[279, 378, 477, 576, 675, 774, 873, 972, 1071, 1170, 1269, 1368](#) - Thermostat x - Valve protection duration (2 - Byte - 7.006 DPT_TimePeriodMin)

■ Smart valve protection

This function is used to activate valve protection, taking into account the number of activations and the operating time of the valve.

Example: Valve protection activation periodicity: every week

Valve protection duration: 5 minutes

When smart valve protection is activated, valve protection is activated if the pump has not been activated for more than 5 minutes over a period of one week.

Parameter	Description	Value
Smart valve protection	The smart pump protection function is deactivated.	No
	The smart pump protection function is activated.	Yes*

Parameter	Description	Value
Valve protection minimum command value	This parameter defines the valve protection minimum command value. Smart valve protection is then only carried out on a regular basis if the minimum parameter limit value configured at this point is not exceeded.	0 ... 80* ... 100%

*Note: This parameter is only visible if the **Smart valve protection** parameter has the value **Yes**.*

* Default value

3.3.2.4 Presence detection

To activate comfort mode extension, a button or a presence detector can be used. It is possible to extend comfort mode for a configurable duration using the **Presence** object.

Parameter	Description	Value
Presence detection	The Presence detection tab and all the parameters linked to the function are: Displayed. Hidden.	Yes No*

Communication objects:

[258](#), [357](#), [456](#), [555](#), [654](#), [753](#), [852](#), [951](#), [1050](#), [1149](#), [1248](#), [1347](#) - Thermostat x - Presence (1 - Bit - 1.001 DPT_Switch)

Parameter	Description	Value
Comfort lengthening time	This parameter defines the duration of comfort mode extension when presence is detected.	00:01 ... 00:30* ... 23:59 (hh:mm)

3.3.3 Function selection

Timer	<input checked="" type="checkbox"/>
Priority	<input checked="" type="checkbox"/>
Automatic control	<input checked="" type="checkbox"/>
Automatic control deactivation	<input type="checkbox"/>
Scene	<input checked="" type="checkbox"/>
Preset	<input checked="" type="checkbox"/>
Lock-up	<input checked="" type="checkbox"/>
Number of lock-up objects	<input type="radio"/> 1 <input checked="" type="radio"/> 2

* Default value

Parameter	Description	Value
Timer	The Timer tab and the associated parameters and objects are: Displayed. Hidden.	Active Not active*

Communication objects:

[266, 365, 464, 563, 662, 761, 860, 959, 1058, 1157, 1256, 1355](#) - Thermostat x - Timer (1 - Bit - 1.010 DPT_Start)

For configuration see section: [Timer](#).

Parameter	Description	Value
Priority	The Priority tab and the associated parameters and objects are: Displayed. Hidden.	Active Not active*

Communication objects:

[191, 290, 389, 488, 587, 686, 785, 884, 983, 1082, 1181, 1280](#) - Thermostat x - Priority (2 - Bit - 2.002 DPT_Bool_Control)

For configuration see section: [Priority](#).

Parameter	Description	Value
Automatic control	The Setpoint selection automatic control object and all the parameters linked to the function are: Displayed. Hidden.	Active Not active*

The Automatic control function is used to control a thermostat in parallel to the Setpoint selection function. The two functions have the same level of priority. The last control received will act on the thermostat status.

An additional command object is used to activate or deactivate the Automatic control.

Example: When a thermostat is controlled by a push-button and in parallel by an automatic control (timer, twilight switch, weather station, etc.) the automatic control can be deactivated for reasons of comfort (vacations, public holidays, etc.).

Communication objects:

[188, 287, 386, 485, 584, 683, 782, 881, 980, 1079, 1178, 1277](#) - Thermostat x - Setpoint selection automatic control (1 - Byte - 20.102 DPT_HVACMode)

* Default value

Parameter	Description	Value
Automatic control deactivation	The objects and the associated parameters are displayed.	Active
	The objects and the associated parameters are hidden.	Not active*

Communication objects:

189, 288, 387, 486, 585, 684, 783, 882, 981, 1080, 1179, 1278 - Thermostat x - Automatic control deactivation (1 - Bit -1.003 DPT_Enable)

197, 296, 395, 494, 593, 692, 791, 890, 989, 1088, 1187, 1286 - Thermostat x - Automatic control deactivation status (1 - Bit - 1.003 DPT_Enable)

Operating principle

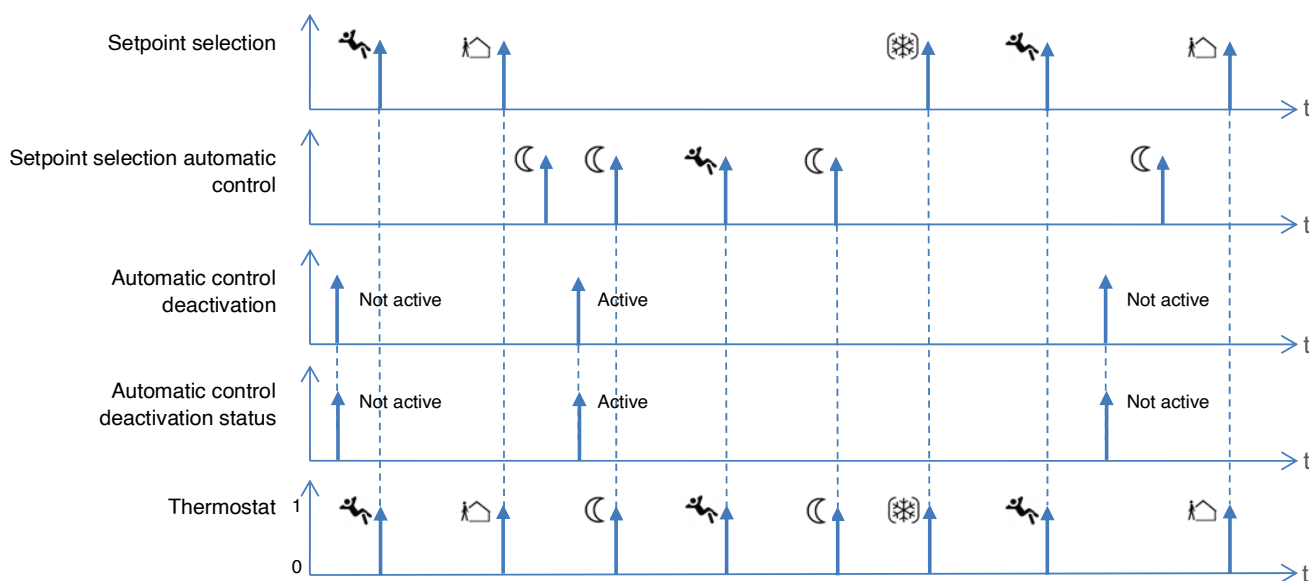

Mode	Symbols
Comfort	
Standby	
Night setpoint	
Frost/heat protection	

* Default value

Parameter	Description	Value
Scene	The Scenes tab and the associated parameters and objects are: Displayed. Hidden.	Active Not active*

Communication objects:

[195](#), [294](#), [393](#), [492](#), [591](#), [690](#), [789](#), [888](#), [987](#), [1086](#), [1185](#), [1284](#) - Thermostat x - Scene (1 - Byte - 18.001 DPT_SceneControl)

Parameter	Description	Value
Preset	The Preset tab and the associated parameters and objects are: Displayed. Hidden.	Active Not active*

Parameter	Description	Value
Number of Preset objects	The Preset tab and the associated parameters and objects are: Displayed for 1 Preset object. Displayed for 2 Preset objects.	1* 2

Communication objects Preset 1:

[269](#), [368](#), [467](#), [566](#), [665](#), [764](#), [863](#), [962](#), [1061](#), [1160](#), [1259](#), [1358](#) - Thermostat x - Preset 1 (1 - Bit - 1.003 DPT_Enable)

Communication objects Preset 2:

[270](#), [369](#), [468](#), [567](#), [666](#), [765](#), [864](#), [963](#), [1062](#), [1161](#), [1260](#), [1359](#) - Thermostat x - Preset 2 (1 - Bit - 1.003 DPT_Enable)

For configuration see section: [Preset](#).

Parameter	Description	Value
Lock-up	The Lock-up tab and the associated parameters and objects are: Displayed. Hidden.	Active Not active*

* Default value

Parameter	Description	Value
Number of lock-up objects	The Lock-up tab and the associated parameters and objects are: Displayed for 1 lock-up object. Displayed for 2 lock-up objects.	1* 2

Communication objects Lock-up 1:

[273](#), [372](#), [471](#), [570](#), [669](#), [768](#), [867](#), [966](#), [1065](#), [1164](#), [1263](#), [1362](#) - Thermostat x - Lock-up 1 (1 - Bit - 1.003 DPT_Enable)

Communication objects Lock-up 2:

[274](#), [373](#), [472](#), [571](#), [670](#), [769](#), [868](#), [967](#), [1066](#), [1165](#), [1264](#), [1363](#) - Thermostat x - Lock-up 2 (1 - Bit - 1.003 DPT_Enable)

For configuration see section: [Lock-up](#).

3.3.4 Basic heating

This menu is used to adjust the parameters (type of heating, regulation type, etc.) for the main heating. In heating mode, the thermostat activates the heating of the room temperature falls below the requested temperature plus a hysteresis. The regulation deactivates the heating as soon as the requested temperature corresponding to the heating mode is reached.

Type of heating control	Switching PI-control (PWM) ▼
Type of heating equipment	Warm water heating ▼
Cycle time	15 min ▼
Polarity	<input checked="" type="radio"/> Not inverted <input type="radio"/> Inverted
Ventilation also used for heating	<input type="checkbox"/>
Emergency command value	30 ▲▼ %

Parameter	Description	Value
Type of heating control	This parameter is used to select the heating regulation type.	Continuous PI-control Switching PI-control (PWM)* Switching 2-point control

The type of regulator is used to select the regulation valve control.

* Default value

■ Switching 2-point control

Switching 2-point control is the simplest type of regulation. This regulation algorithm cuts off the output as soon as the upper setpoint temperature is exceeded. It rearms it when the temperature falls again. The regulator has a built-in hysteresis to avoid it constantly switching the output value. The regulator then calculates the switching and tripping threshold according to the hysteresis and requested value. This type of regulator is used when the output value only accepts the two statuses (ON or OFF) and the real temperature does not need to be accurately controlled in relation to the setpoint value. Due to the inertia of the heating system, the real temperature oscillates slightly below the switching point and slightly exceeds the tripping point. The real temperature therefore always varies in a range slightly higher than the configured hysteresis.

■ Continuous PI-control

The regulation output is a value in percent ranging from 0% to 100%. The PI regulator adapts its calibrated output value between 0% and 100% to the difference between the real value and the setpoint value, thus allowing exact adjustment of the room temperature to the setpoint value. It supplies the calibrated value on the bus in the form of a 1 byte value (0 ... 100%). To reduce the workload on the bus, the calibrated value is only sent if it has changed by a previously defined percent in relation to the last value sent. The calibrated value can be sent periodically in addition.

■ Switching PI-control (PWM)*

This regulation also has a continuous PI-control. However, for this type of regulation, the output signal (0 to 100%) for the PID regulation is not sent but only processed internally. Based on the PID regulation output signal, the regulation then converts the output signal to an ON and OFF pulse. This pulse does not have a fixed ON/OFF point as with the 2 point control, but the pulse length is determined using the output value calculated by the PID regulation (cycle time). The higher the calculated output value, the higher the time ratio between ON and OFF.

A short cycle time causes ON pulses at relatively short intervals. This avoids too great a temperature drop and the real value remains largely stable. However, this may also lead to the switching frequency being too high, which may affect the system or overload the KNX communication bus.

Example:

Value 100%: Always ON

Value 0%: Always OFF

30% value with cycle duration of 10 minutes: 3 min ON and 7 min OFF

* Default value

Parameter	Description	Value
Type of heating equipment	This parameter is used to select the type of heating.	Warm water heating* Warm water underfloor heating Electric heating Electrical underfloor heating Fancoil Split unit Through control parameter

Note: A fancoil is an air treatment device designed to heat or cool the air. The thermal energy is provided by a fluid (water or refrigerant fluid) or by Joule effect (electricity).

Note: A Split unit is an air conditioner in which the cool air blower is separated into two parts connected by a refrigerant link transporting the calories from the inside unit to the external unit.

Communication objects:

[202, 301, 400, 499, 598, 697, 796, 895, 994, 1093, 1192, 1291](#) - Thermostat x - ON/OFF (1 - Bit - 1.001 DPT_Switch)

[203, 302, 401, 500, 599, 698, 797, 896, 995, 1094, 1193, 1292](#) - Thermostat x - Valve position in % (8 - Bit - 5.001 DPT_Scaling)

■ Switching PI-control (PWM)

Parameter	Description	Value
Cycle time	This parameter is used to adapt the regulation to the types of valves used. It defines the pulse-width modulation signal switching frequency and allows the valves used to be adapted to the changeover cycle times (time required for the valve to switch from closed position to open position).	5 min, 10 min, 15 min* , 20 min, 25 min, 30 min, 35 min, 40 min, 45 min, 1 h, 1 h15, 1 h45

Parameter	Description	Value
Polarity	This parameter is used to adapt the regulation to the corresponding electrothermal motors.	Not inverted* Inverted

Parameter	Description	Value
Command value when emergency active	This parameter defines the command value when the regulator switches to emergency mode.	0 ... 30* ... 100%

Parameter	Description	Value
Command value when emergency active in summer	This parameter defines the command value when the output switches to emergency mode for the summer.	0 ... 30* ... 100%

*Note: This parameter is only visible if the **Summer/winter mode changeover** parameter has the value **Yes**.*

* Default value

Parameter	Description	Value
Command value when emergency active in winter	This parameter defines the command value when the output switches to emergency mode for the winter.	0 ... 70* ... 100%

*Note: This parameter is only visible if the **Summer/winter mode changeover** parameter has the value **Yes**.*

Parameter	Description	Value
Floor temperature limitation	This parameter is used to limit the floor temperature.	Active* Not active

*Note: This parameter is only visible if the **Type of heating equipment** parameter has the value **Warm water underfloor heating** or **Electrical underfloor heating**.*

Communication objects:

[213](#), [312](#), [411](#), [510](#), [609](#), [708](#), [807](#), [906](#), [1005](#), [1104](#), [1203](#), [1302](#) - Thermostat x - Floor temperature (2 - Byte - 9.001 DPT_Value_Temp)

Parameter	Description	Value
Ventilation also used for heating	This parameter allows a fan to be used as a heating aid.	Active Not active*

*Note: This parameter is only visible if the **Ventilation available** parameter has the value **Active**.*

- Through control parameter

If the predefined settings are not suitable, the regulation curve can be configured. The presetting of the proportional range for the heating or cooling and the subsequent adjustment time for the heating or cooling significantly influence the regulation.

Parameter	Description	Value
Proportional range	This parameter defines the value of the proportional range. It varies around the setpoint value and is used in case of PI regulation to influence the speed of regulation. The smaller the adjusted value, the quicker the regulation reacts.	0.5 K - 1.0 K - 1.5 K - 2.0 K - 2.5 K - 3.0 K* - 3.5 K - 4.0 K - 4.5 K - 5.0 K - 5.5 K - 6.0 K
Integration time	This parameter defines the duration of the integral component. It provides a notion of integration time to the correction. This action is complementary to the proportional action and stabilises the proportional action over time. The more constant the measured error is, the more constant the correction is.	Not active - 15 min - 30 min* - 45 min - 1 h - 1 h 15 min - 1 h 30 min - 1 h 45 min - 2 h - 2 h 15 min - 2 h 30 min - 2 h 45 min - 3 h - 3 h 15 min - 3 h 30 min
Derivative time	This parameter defines the duration of the derivative component. It makes it possible to anticipate the response of the regulation in case of rapid disturbance or setpoint modification, which improves the stability of the system.	Not active - 15 min - 30 min* - 45 min - 1 h - 1 h 15 min - 1 h 30 min - 1 h 45 min - 2 h - 2 h 15 min - 2 h 30 min - 2 h 45 min - 3 h - 3 h 15 min - 3 h 30 min

Note: The smallest modification of a regulation parameter leads to significantly different regulation behaviour.

Note: A temperature offset is expressed in Kelvin. 1K of temperature offset corresponds to 1°C.

* Default value

■ Switching 2-point control

Parameter	Description	Value
Hysteresis	This parameter defines the hysteresis value for the value to be regulated. The hysteresis of the 2-point regulator indicates the regulator fluctuation width around the setpoint value.	+/- 0.3K, +/- 0.5 K* , +/- 0.7 K, +/- 1.0 K, +/- 1.5 K, +/- 2.0 K, +/- 2.5 K, +/- 3.0 K

Note: A temperature offset is expressed in Kelvin. 1K of temperature offset corresponds to 1°C.

Parameter	Description	Value
Hysteresis duration	This parameter defines the hysteresis duration for the value to be regulated.	Not active, 1 min, 2 min, 3 min, 4 min, 5 min* , 6 min, 7 min, 8 min, 9 min, 10 min

Parameter	Description	Value
Polarity	This parameter is used to adapt the regulation to the corresponding electrothermal motors.	Not inverted* Inverted

Parameter	Description	Value
Command value when emergency active	This parameter defines the command value when the regulator switches to emergency mode.	0 ... 30* ... 100%

Note: For a **Continuous PI-control** only the **Emergency command value** is available.

Parameter	Description	Value
Command value when emergency active in summer	This parameter defines the command value when the output switches to emergency mode for the summer.	0 ... 30* ... 100%

Note: This parameter is only visible if the **Summer/winter mode changeover** parameter has the value **Yes**.

Parameter	Description	Value
Command value when emergency active in winter	This parameter defines the command value when the output switches to emergency mode for the winter.	0 ... 70* ... 100%

Note: This parameter is only visible if the **Summer/winter mode changeover** parameter has the value **Yes**.

* Default value

3.3.5 Additional heating

This menu is used to adjust the (type of heating, regulation type, etc.) parameters for secondary heating.

Type of heating control	Switching PI-control (PWM) ▼
Type of heating equipment	Warm water heating ▼
Cycle time	15 min ▼
Polarity	<input checked="" type="radio"/> Not inverted <input type="radio"/> Inverted
Emergency command value	30 ▲▼ %

Parameter	Description	Value
Type of heating control	This parameter is used to select the heating regulation type.	Continuous PI-control Switching PI-control (PWM)* Switching 2-point control

Note: For the operation of the different types of regulation, please refer to chapter [Basic heating](#).

Parameter	Description	Value
Type of heating equipment	This parameter is used to select the type of heating.	Warm water heating* Warm water underfloor heating Electric heating Electrical underfloor heating Fancoil Split unit Through control parameter

Note: A fancoil is an air treatment device designed to heat or cool the air. The thermal energy is provided by a fluid (water or refrigerant fluid) or by Joule effect (electricity).

Note: A Split unit is an air conditioner in which the cool air blower is separated into two parts connected by a refrigerant link transporting the calories from the inside unit to the external unit.

Communication objects:

[206, 305, 404, 503, 602, 701, 800, 899, 998, 1097, 1196, 1295](#) - Thermostat x - ON/OFF - additional heating (1 - Bit - 1.001 DPT_Switch)

[207, 306, 405, 504, 603, 702, 801, 900, 999, 1098, 1197, 1296](#) - Thermostat x - Valve position in % - additional heating (8 - Bit - 5.001 DPT_Scaling)

* Default value

■ Switching PI-control (PWM)

Parameter	Description	Value
Cycle time	This parameter is used to adapt the regulation to the types of valves used. It defines the pulse-width modulation signal switching frequency and allows the valves used to be adapted to the changeover cycle times (time required for the valve to switch from closed position to open position).	5 min, 10 min, 15 min* , 20 min, 25 min, 30 min, 35 min, 40 min, 45 min, 1 h, 1 h15, 1 h45

Parameter	Description	Value
Polarity	This parameter is used to adapt the regulation to the corresponding electrothermal motors.	Not inverted* Inverted

Parameter	Description	Value
Command value when emergency active	This parameter defines the command value when the regulator switches to emergency mode.	0 ... 30* ... 100%

Parameter	Description	Value
Command value when emergency active in summer	This parameter defines the command value when the output switches to emergency mode for the summer.	0 ... 30* ... 100%

*Note: This parameter is only visible if the **Summer/winter mode changeover** parameter has the value **Yes**.*

Parameter	Description	Value
Command value when emergency active in winter	This parameter defines the command value when the output switches to emergency mode for the winter.	0 ... 70* ... 100%

*Note: This parameter is only visible if the **Summer/winter mode changeover** parameter has the value **Yes**.*

Parameter	Description	Value
Floor temperature limitation	This parameter is used to limit the floor temperature.	Active* Not active

*Note: This parameter is only visible if the **Type of heating equipment** parameter has the value **Warm water underfloor heating** or **Electrical underfloor heating**.*

Communication objects:

[213](#), [312](#), [411](#), [510](#), [609](#), [708](#), [807](#), [906](#), [1005](#), [1104](#), [1203](#), [1302](#) - **Thermostat x - Floor temperature (2 - Byte - 9.001 DPT_Value_Temp)**

* Default value

- Through control parameter

If the predefined settings are not suitable, the regulation curve can be configured. The presetting of the proportional range for the heating or cooling and the subsequent adjustment time for the heating or cooling significantly influence the regulation.

Parameter	Description	Value
Proportional range	This parameter defines the value of the proportional range. It varies around the setpoint value and is used in case of PI regulation to influence the speed of regulation. The smaller the adjusted value, the quicker the regulation reacts.	0.5 K - 1.0 K - 1.5 K - 2.0 K - 2.5 K - 3.0 K* - 3.5 K - 4.0 K - 4.5 K - 5.0 K - 5.5 K - 6.0 K
Integration time	This parameter defines the duration of the integral component. It provides a notion of integration time to the correction. This action is complementary to the proportional action and stabilises the proportional action over time. The more constant the measured error is, the more constant the correction is.	Not active - 15 min - 30 min* - 45 min - 1 h - 1 h 15 min - 1 h 30 min - 1 h 45 min - 2 h - 2 h 15 min - 2 h 30 min - 2 h 45 min - 3 h - 3 h 15 min - 3 h 30 min
Derivative time	This parameter defines the duration of the derivative component. It makes it possible to anticipate the response of the regulation in case of rapid disturbance or setpoint modification, which improves the stability of the system.	Not active - 15 min - 30 min* - 45 min - 1 h - 1 h 15 min - 1 h 30 min - 1 h 45 min - 2 h - 2 h 15 min - 2 h 30 min - 2 h 45 min - 3 h - 3 h 15 min - 3 h 30 min

Note: The smallest modification of a regulation parameter leads to significantly different regulation behaviour.

Note: A temperature offset is expressed in Kelvin. 1K of temperature offset corresponds to 1°C.

■ Switching 2-point control

Parameter	Description	Value
Hysteresis	This parameter defines the hysteresis value for the value to be regulated. The hysteresis of the 2-point regulator indicates the regulator fluctuation width around the setpoint value.	+/- 0.3K, +/- 0.5 K* , +/- 0.7 K, +/- 1.0 K, +/- 1.5 K, +/- 2.0 K, +/- 2.5 K, +/- 3.0 K

Note: A temperature offset is expressed in Kelvin. 1K of temperature offset corresponds to 1°C.

Parameter	Description	Value
Hysteresis duration	This parameter defines the hysteresis duration for the value to be regulated.	Not active, 1 min, 2 min, 3 min, 4 min, 5 min* , 6 min, 7 min, 8 min, 9 min, 10 min

Parameter	Description	Value
Polarity	This parameter is used to adapt the regulation to the corresponding electrothermal motors.	Not inverted* Inverted

* Default value

Parameter	Description	Value
Command value when emergency active	This parameter defines the command value when the regulator switches to emergency mode.	0 ... 30* ... 100%

Note: For a **Continuous PI-control** only the **Emergency command value** is available.

Parameter	Description	Value
Command value when emergency active in summer	This parameter defines the command value when the output switches to emergency mode for the summer.	0 ... 30* ... 100%

Note: This parameter is only visible if the **Summer/winter mode changeover** parameter has the value **Yes**.

Parameter	Description	Value
Command value when emergency active in winter	This parameter defines the command value when the output switches to emergency mode for the winter.	0 ... 70* ... 100%

Note: This parameter is only visible if the **Summer/winter mode changeover** parameter has the value **Yes**.

3.3.6 Basic cooling

This menu is used to adjust the (type of cooling, regulation type, etc.) parameters for the main cooling. In cooling mode, the thermostat activates cooling if the room temperature rises above the requested value plus a hysteresis. The regulation deactivates cooling as soon as the requested temperature corresponding to the cooling mode is reached.

Type of cooling control	Switching PI-control (PWM) ▼
Type of cooling equipment	Cooling ceiling ▼
Cycle time	15 min ▼
Polarity	<input checked="" type="radio"/> Not inverted <input type="radio"/> Inverted
Ventilation also used for cooling	<input type="checkbox"/>
Emergency command value	70 ▲▼ %

Parameter	Description	Value
Type of cooling control	This parameter is used to select the cooling regulation type.	Continuous PI-control Switching PI-control (PWM)* Switching 2-point control

Note: For the operation of the different types of regulation, please refer to chapter [Basic heating](#).

* Default value

Parameter	Description	Value
Type of cooling equipment	This parameter is used to select the cooling type.	Cooling ceiling* Fancoil Split unit Through control parameter

Note: A fancoil is an air treatment device designed to heat or cool the air. The thermal energy is provided by a fluid (water or refrigerant fluid) or by Joule effect (electricity).

Note: A Split unit is an air conditioner in which the cool air blower is separated into two parts connected by a refrigerant link transporting the calories from the inside unit to the external unit.

Communication objects:

[204, 303, 402, 501, 600, 699, 798, 897, 996, 1095, 1194, 1293](#) - Thermostat x - Basic cooling (1 - Bit - 1.001 DPT_Switch)

[205, 304, 403, 502, 601, 700, 799, 898, 997, 1096, 1195, 1294](#) - Thermostat x - Valve position in % - basic cooling (8 - Bit - 5.001 DPT_Scaling)

■ Switching PI-control (PWM)

Parameter	Description	Value
Cycle time	This parameter is used to adapt the regulation to the types of valves used. It defines the pulse-width modulation signal switching frequency and allows the valves used to be adapted to the changeover cycle times (time required for the valve to switch from closed position to open position).	5 min, 10 min, 15 min* , 20 min, 25 min, 30 min, 35 min, 40 min, 45 min, 1 h, 1 h15, 1 h45

Parameter	Description	Value
Polarity	This parameter is used to adapt the regulation to the corresponding electrothermal motors.	Not inverted* Inverted

Parameter	Description	Value
Command value when emergency active	This parameter defines the command value when the regulator switches to emergency mode.	0 ... 30* ... 100%

Parameter	Description	Value
Command value when emergency active in summer	This parameter defines the command value when the output switches to emergency mode for the summer.	0 ... 30* ... 100%

*Note: This parameter is only visible if the **Summer/winter mode changeover** parameter has the value **Yes**.*

Parameter	Description	Value
Command value when emergency active in winter	This parameter defines the command value when the output switches to emergency mode for the winter.	0 ... 70* ... 100%

*Note: This parameter is only visible if the **Summer/winter mode changeover** parameter has the value **Yes**.*

* Default value

Parameter	Description	Value
Ventilation also used for cooling	This parameter allows a fan to be used as a cooling aid.	Active Not active*

*Note: This parameter is only visible if the **Ventilation available** parameter has the value **Active**.*

- Through control parameter

If the predefined settings are not suitable, the regulation curve can be configured. The presetting of the proportional range for the heating or cooling and the subsequent adjustment time for the heating or cooling significantly influence the regulation.

Parameter	Description	Value
Proportional range	This parameter defines the value of the proportional range. It varies around the setpoint value and is used in case of PI regulation to influence the speed of regulation. The smaller the adjusted value, the quicker the regulation reacts.	0.5 K - 1.0 K - 1.5 K - 2.0 K - 2.5 K - 3.0 K* - 3.5 K - 4.0 K - 4.5 K - 5.0 K - 5.5 K - 6.0 K
Integration time	This parameter defines the duration of the intergral component. It provides a notion of integration time to the correction. This action is complementary to the proportional action and stabilises the proportional action over time. The more constant the measured error is, the more constant the correction is.	Not active - 15 min - 30 min* - 45 min - 1 h - 1 h 15 min - 1 h 30 min - 1 h 45 min - 2 h - 2 h 15 min - 2 h 30 min - 2 h 45 min - 3 h - 3 h 15 min - 3 h 30 min
Derivative time	This parameter defines the duration of the derivative component. It makes it possible to anticipate the response of the regulation in case of rapid disturbance or setpoint modification, which improves the stability of the system.	Not active - 15 min - 30 min* - 45 min - 1 h - 1 h 15 min - 1 h 30 min - 1 h 45 min - 2 h - 2 h 15 min - 2 h 30 min - 2 h 45 min - 3 h - 3 h 15 min - 3 h 30 min

Note: The smallest modification of a regulation parameter leads to significantly different regulation behaviour.

Note: A temperature offset is expressed in Kelvin. 1K of temperature offset corresponds to 1°C.

■ Switching 2-point control

Parameter	Description	Value
Hysteresis	This parameter defines the hysteresis value for the value to be regulated. The hysteresis of the 2-point regulator indicates the regulator fluctuation width around the setpoint value.	+/- 0.3K, +/- 0.5 K* , +/- 0.7 K, +/- 1.0 K, +/- 1.5 K, +/- 2.0 K, +/- 2.5 K, +/- 3.0 K

Note: A temperature offset is expressed in Kelvin. 1K of temperature offset corresponds to 1°C.

Parameter	Description	Value
Hysteresis duration	This parameter defines the hysteresis duration for the value to be regulated.	Not active, 1 min, 2 min, 3 min, 4 min, 5 min* , 6 min, 7 min, 8 min, 9 min, 10 min

* Default value

Parameter	Description	Value
Polarity	This parameter is used to adapt the regulation to the corresponding electrothermal motors.	Not inverted* Inverted

Parameter	Description	Value
Command value when emergency active	This parameter defines the command value when the regulator switches to emergency mode.	0 ... 30* ... 100%

Note: For a **Continuous PI-control** only the **Emergency command value** is available.

Parameter	Description	Value
Command value when emergency active in summer	This parameter defines the command value when the output switches to emergency mode for the summer.	0 ... 30* ... 100%

Note: This parameter is only visible if the **Summer/winter mode changeover** parameter has the value **Yes**.

Parameter	Description	Value
Command value when emergency active in winter	This parameter defines the command value when the output switches to emergency mode for the winter.	0 ... 70* ... 100%

Note: This parameter is only visible if the **Summer/winter mode changeover** parameter has the value **Yes**.

3.3.7 Additional cooling

This menu is used to adjust the (type of cooling, regulation type, etc.) for the secondary cooling.

Type of cooling control	Switching PI-control (PWM) ▼
Type of cooling equipment	Cooling ceiling ▼
Cycle time	15 min ▼
Polarity	<input checked="" type="radio"/> Not inverted <input type="radio"/> Inverted
Emergency command value	70 ▲▼ %

Parameter	Description	Value
Type of heating control	This parameter is used to select the heating regulation type.	Continuous PI-control Switching PI-control (PWM)* Switching 2-point control

Note: For the operation of the different types of regulation, please refer to chapter [Basic heating](#).

* Default value

Parameter	Description	Value
Type of heating equipment	This parameter is used to select the type of heating.	Cooling ceiling* Fancoil Split unit Through control parameter

Note: A fancoil is an air treatment device designed to heat or cool the air. The thermal energy is provided by a fluid (water or refrigerant fluid) or by Joule effect (electricity).

Note: A Split unit is an air conditioner in which the cool air blower is separated into two parts connected by a refrigerant link transporting the calories from the inside unit to the external unit.

Communication objects:

[208, 307, 406, 505, 604, 703, 802, 901, 1000, 1099, 1198, 1297](#) - Thermostat x - Additional cooling (1 - Bit - 1.001 DPT_Switch)

[209, 308, 407, 506, 605, 704, 803, 902, 1001, 1100, 1199, 1298](#) - Thermostat x - Valve position in % - additional cooling (8 - Bit - 5.001 DPT_Scaling)

■ Switching PI-control (PWM)

Parameter	Description	Value
Cycle time	This parameter is used to adapt the regulation to the types of valves used. It defines the pulse-width modulation signal switching frequency and allows the valves used to be adapted to the changeover cycle times (time required for the valve to switch from closed position to open position).	5 min, 10 min, 15 min* , 20 min, 25 min, 30 min, 35 min, 40 min, 45 min, 1 h, 1 h15, 1 h45

Parameter	Description	Value
Polarity	This parameter is used to adapt the regulation to the corresponding electrothermal motors.	Not inverted* Inverted

Parameter	Description	Value
Command value when emergency active	This parameter defines the command value when the regulator switches to emergency mode.	0 ... 30* ... 100%

Parameter	Description	Value
Command value when emergency active in summer	This parameter defines the command value when the output switches to emergency mode for the summer.	0 ... 30* ... 100%

*Note: This parameter is only visible if the **Summer/winter mode changeover** parameter has the value **Yes**.*

Parameter	Description	Value
Command value when emergency active in winter	This parameter defines the command value when the output switches to emergency mode for the winter.	0 ... 70* ... 100%

*Note: This parameter is only visible if the **Summer/winter mode changeover** parameter has the value **Yes**.*

* Default value

- Through control parameter

If the predefined settings are not suitable, the regulation curve can be configured. The presetting of the proportional range for the heating or cooling and the subsequent adjustment time for the heating or cooling significantly influence the regulation.

Parameter	Description	Value
Proportional range	This parameter defines the value of the proportional range. It varies around the setpoint value and is used in case of PI regulation to influence the speed of regulation. The smaller the adjusted value, the quicker the regulation reacts.	0.5 K - 1.0 K - 1.5 K - 2.0 K - 2.5 K - 3.0 K* - 3.5 K - 4.0 K - 4.5 K - 5.0 K - 5.5 K - 6.0 K
Integration time	This parameter defines the duration of the integral component. It provides a notion of integration time to the correction. This action is complementary to the proportional action and stabilises the proportional action over time. The more constant the measured error is, the more constant the correction is.	Not active - 15 min - 30 min* - 45 min - 1 h - 1 h 15 min - 1 h 30 min - 1 h 45 min - 2 h - 2 h 15 min - 2 h 30 min - 2 h 45 min - 3 h - 3 h 15 min - 3 h 30 min
Derivative time	This parameter defines the duration of the derivative component. It makes it possible to anticipate the response of the regulation in case of rapid disturbance or setpoint modification, which improves the stability of the system.	Not active - 15 min - 30 min* - 45 min - 1 h - 1 h 15 min - 1 h 30 min - 1 h 45 min - 2 h - 2 h 15 min - 2 h 30 min - 2 h 45 min - 3 h - 3 h 15 min - 3 h 30 min

Note: The smallest modification of a regulation parameter leads to significantly different regulation behaviour.

Note: A temperature offset is expressed in Kelvin. 1K of temperature offset corresponds to 1°C.

■ Switching 2-point control

Parameter	Description	Value
Hysteresis	This parameter defines the hysteresis value for the value to be regulated. The hysteresis of the 2-point regulator indicates the regulator fluctuation width around the setpoint value.	+/- 0.3K, +/- 0.5 K* , +/- 0.7 K, +/- 1.0 K, +/- 1.5 K, +/- 2.0 K, +/- 2.5 K, +/- 3.0 K

Note: A temperature offset is expressed in Kelvin. 1K of temperature offset corresponds to 1°C.

Parameter	Description	Value
Hysteresis duration	This parameter defines the hysteresis duration for the value to be regulated.	Not active, 1 min, 2 min, 3 min, 4 min, 5 min* , 6 min, 7 min, 8 min, 9 min, 10 min

Parameter	Description	Value
Polarity	This parameter is used to adapt the regulation to the corresponding electrothermal motors.	Not inverted* Inverted

Parameter	Description	Value
Command value when emergency active	This parameter defines the command value when the regulator switches to emergency mode.	0 ... 30* ... 100%

*Note: For a **Continuous PI-control** only the **Emergency command value** is available.*

Parameter	Description	Value
Command value when emergency active in summer	This parameter defines the command value when the output switches to emergency mode for the summer.	0 ... 30* ... 100%

*Note: This parameter is only visible if the **Summer/winter mode changeover** parameter has the value **Yes**.*

Parameter	Description	Value
Command value when emergency active in winter	This parameter defines the command value when the output switches to emergency mode for the winter.	0 ... 70* ... 100%

*Note: This parameter is only visible if the **Summer/winter mode changeover** parameter has the value **Yes**.*

* Default value

3.3.8 Ventilation

In its room thermostat function, the device can also control the fancoil actuators. In general, the fancoil actuators are connected to heating or air conditioning fans.

i No fan control with switching 2-point regulation type

Polarity
 0 = automatic mode, 1 = manual mode
 1 = automatic mode, 0 = manual mode

Ventilation object
 Object (1 bit) Value object (1 byte)

Number of ventilation steps 3 steps ▼

Start ventilation step 1 by 1 %

Start ventilation step 2 by 20 %

Start ventilation step 3 by 40 %

Hysteresis 3 %

Timing between ventilation step 200 ms

Ventilation step on manual switching OFF ▼

Overrun time heating 0 ms

Overrun time cooling 0 ms

Start ventilation step Step 1 ▼

* Default value

Parameter	Description	Value
Polarity	<p>The Ventilation automatic/manual mode object receives:</p> <p>0 = Ventilation is in automatic mode 1 = Ventilation is in manual mode</p> <p>1 = Ventilation is in automatic mode 0 = Ventilation is in manual mode</p>	<p>0 = automatic mode, 1 = manual mode*</p> <p>1 = automatic mode, 0 = manual mode</p>

Automatic mode: The level of ventilation goes directly to the level corresponding to the regulation power.

Manual mode: The ventilation level is adjusted to a configurable start-up manual mode level and the output power has no impact on the ventilation level.

Communication objects:

[218, 317, 416, 515, 614, 713, 812, 911, 1010, 1109, 1208, 1307](#) - Thermostat x - Ventilation automatic/manual mode (1 - Bit - 1.001 DPT_Switch)

Parameter	Description	Value
Ventilation object	<p>The ventilation control is operated using</p> <p>A 1 bit object. Each ventilation level (1 to 6) has a communication object.</p> <p>A 1 byte object. All the ventilation levels are sent by a single object.</p>	<p>Object (1 bit)</p> <p>Value object (1 byte)*</p>

Note: There is a status feedback object for all the ventilation levels.

1 bit ventilation objects step 1:

[227, 326, 425, 524, 623, 722, 821, 920, 1019, 1118, 1217, 1316](#) - Thermostat x - Ventilation step 1 (1 - Bit - 1.001 DPT_Switch)

[220, 319, 418, 517, 616, 715, 814, 913, 1012, 1111, 1210, 1309](#) - Thermostat x - Status ventilation step 1 (1 - Bit - 1.001 DPT_Switch)

1 byte ventilation objects steps 1-6:

[226, 325, 424, 523, 622, 721, 820, 919, 1018, 1117, 1216, 1315](#) - Thermostat x - Ventilation step 1-6 (8 - Bit - 5.010 DPT_Value_1_Ucount)

[219, 318, 417, 516, 615, 714, 813, 912, 1011, 1110, 1209, 1308](#) - Thermostat x - Status ventilation step 1-6 (8 - Bit - 5.010 DPT_Value_1_Ucount)

* Default value

Parameter	Description	Value
Number of ventilation steps	This parameter is used to define the number of ventilation steps (6 maximum).	Not active 1 step 2 steps 3 steps* 4 steps 5 steps 6 steps

Note: According to the number of ventilation steps, the same number of 1 bit objects will appear for the control and for the status feedback.

Parameter	Description	Value
Start ventilation step X by	This parameter is used to define the start-up value for each step. Different default values are proposed for each step.	0 ... 100%

X = 1 to 6

Note: This parameter is available for each ventilation step.

Parameter	Description	Value
Hysteresis	This parameter is used to define the hysteresis value for all the ventilation steps.	0 ... 3* ... 100%

Parameter	Description	Value
Timing between ventilation step	This parameter is used to define the time the ventilation will take to switch to the upper or lower step.	0 ... 200* ... 25500 ms

Parameter	Description	Value
Ventilation step on manual switching	This parameter is used to define the ventilation step to be applied when switching to manual mode.	OFF* 1 step 2 steps 3 steps 4 steps 5 steps 6 steps No change

Parameter	Description	Value
Overrun time heating	This parameter is used to define a minimum time between heating stopping and ventilation stopping.	0* ... 25500 ms

Parameter	Description	Value
Overrun time cooling	This parameter is used to define a minimum time between cooling stopping and ventilation stopping.	0* ... 25500 ms

Parameter	Description	Value
Start ventilation step	This parameter is used to define the ventilation step to be applied when the ventilation starts up.	Step 1* Step 2 Step 3 Step 4 Step 5 Step 6

* Default value

3.3.9 Temperature measurement

The room thermostat measures the real temperature and compares it to the requested temperature. The adjustment value is calculated based on the difference between the requested temperature and the real temperature using the defined regulation algorithm.

Room temperature detection	Through 3 objects
Temperature 1 weighting	50
Temperature 2 weighting	50
Temperature 3 weighting	50
Timeout of room temperature	00:45 hh:mm
<hr/>	
Floor temperature detection	<input type="radio"/> No <input checked="" type="radio"/> Yes
Timeout of floor temperature	00:45 hh:mm
Maximum floor temperature	28 °C
<hr/>	
Emission	On status change
Value emission by variation of	0,5K
<hr/>	
Emission room temperature alarm through objects	<input checked="" type="checkbox"/>
Minimum room temperature	7 °C
Maximum room temperature	35 °C
Object room temperature failure polarity	<input checked="" type="radio"/> Not inverted <input type="radio"/> Inverted
Object room temperature lower limit alarm polarity	<input checked="" type="radio"/> Not inverted <input type="radio"/> Inverted
Object room temperature upper limit alarm polarity	<input checked="" type="radio"/> Not inverted <input type="radio"/> Inverted

The thermostat detects the room temperature using up to a maximum of 3 external temperature sensors.

* Default value

Parameter	Description	Value
Room temperature detection	This parameter is used to define the number of sensors used to measure the room temperature of the regulation circuit.	Through 1 object* Through 2 objects Through 3 objects

Communication objects:

210, 309, 408, 507, 606, 705, 804, 903, 1002, 1101, 1200, 1299 - Thermostat x - Room temperature 1 (2 - Byte - 9.001 DPT_Value_Temp)

211, 310, 409, 508, 607, 706, 805, 904, 1003, 1102, 1201, 1300 - Thermostat x - Room temperature 2 (2 - Byte - 9.001 DPT_Value_Temp)

212, 311, 410, 509, 608, 707, 806, 905, 1004, 1103, 1202, 1301 - Thermostat x - Room temperature 3 (2 - Byte - 9.001 DPT_Value_Temp)

Weighting is used to calculate a reference temperature in a room when several temperature sensors are used. The temperature weights can be determined according to different external factors influencing the temperature measured by the different sensors.

- Near a window, a door or a source of heat or cold
- Direct exposure to sunlight
- Mounting on an outside wall

Example:

T° 1 = 22 °C, Temperature 1 = 50 weighting

T° 2 = 20 °C, Temperature 2 = 50 weighting

T° 3 = 18 °C, Temperature 3 = 50 weighting

Reference temperature = $(22 \times 50 + 20 \times 50 + 18 \times 50) / (50 + 50 + 50) = 20 \text{ °C}$

T° 1 = 22 °C, Temperature 1 = 100 weighting

T° 2 = 20 °C, Temperature 2 = 50 weighting

T° 3 = 18 °C, Temperature 3 = 25 weighting

Reference temperature = $(22 \times 100 + 20 \times 50 + 18 \times 25) / (100 + 50 + 25) = 20,86 \text{ °C}$

Parameter	Description	Value
Temperature X weighting	This parameter gives a weight to each temperature to determine an average value.	0 ... 50* ... 100

X = 1 to 3

*Note: This parameter is only visible when the parameter **Room temperature detection** has the value **Through 2 objects** or **Through 3 objects**.*

Parameter	Description	Value
Timeout of room temperature	If during temperature measurement no temperature values are received, a fault will be reported after this time has elapsed. This fault is sent using the Room temperature failure object.	00:01 ... 00:45* ... 04:15 (hh:mm)

* Default value

Parameter	Description	Value
Floor temperature detection	This parameter is used to activate the floor temperature measurement of the regulation circuit.	Yes* No

*Note: This parameter is only visible if the **Type of heating equipment** parameter has the value **Warm water underfloor heating** or **Electrical underfloor heating**.*

Parameter	Description	Value
Timeout of floor temperature	If during temperature measurement no temperature values are received, a fault will be reported after this time has elapsed. The product then goes into emergency mode and transmits the command value when emergency active.	00:01 ... 00:45* ... 04:15 (hh:mm)

*Note: This parameter is only visible if the **Floor temperature detection** parameter has the value **Yes**.*

Parameter	Description	Value
Maximum floor temperature	This parameter is used to define the Maximum floor temperature not to be exceeded.	24 ... 28* ... 46 °C

*Note: This parameter is only visible if the **Floor temperature detection** parameter has the value **Yes**.*

Parameter	Description	Value
Emission of the room temperature	The Status indication room temperature object is sent: Each time the value changes taking a hysteresis into account. Periodically after a configurable time. Each time the value changes taking a hysteresis into account and periodically according to a configurable duration.	On status change* Periodically On status change and periodically

Note: This object is used to indicate the real temperature value taken into account by the regulator.

Communication objects:

[214](#), [313](#), [412](#), [511](#), [610](#), [709](#), [808](#), [907](#), [1006](#), [1105](#), [1204](#), [1303](#) - **Thermostat x - Status indication room temperature** (2 - Byte - 9.001 DPT_Value_Temp)

Parameter	Description	Value
Hysteresis for room temperature object emission	To avoid the Status indication room temperature object being sent too repetitively, this parameter determines the value above or below which the room temperature must be sent on the KNX bus.	0.3 K - 0.5 K* - 0.7 K - 1.0 K - 1.5 K - 2.0 K - 2.5 K - 3.0 K

* Default value

Parameter	Description	Value
Periodical emission	This parameter determines the time between the individual transmissions of the Status indication room temperature object.	00:00:01 ... 00:10:00* ... 23:59:59 (hh:mm:ss)

Parameter	Description	Value
Emission room temperature alarm through objects	The objects and the associated parameters are hidden.	Not active*
	The objects and the associated parameters are displayed.	Active

Communication objects:

[215, 314, 413, 512, 611, 710, 809, 908, 1007, 1106, 1205, 1304](#) - Thermostat x - Room temperature failure (1 - Bit - 1.005 DPT_Alarm)

Parameter	Description	Value
Minimum room temperature	If the room temperature is lower than the set value, an alarm is sent on the KNX bus.	0 ... 7* ... 40 °C

*Note: This parameter is only visible if the **Emission room temperature alarm through objects** parameter has the value **Active**.*

Communication objects:

[216, 315, 414, 513, 612, 711, 810, 909, 1008, 1107, 1206, 1305](#) - Thermostat x - Minimum room temperature (1 - Bit - 1.005 DPT_Alarm)

Parameter	Description	Value
Maximum room temperature	If the room temperature is higher than the set value, an alarm is sent on the KNX bus.	0 ... 35* ... 40 °C

*Note: This parameter is only visible if the **Emission room temperature alarm through objects** parameter has the value **Active**.*

Communication objects:

[217, 316, 415, 514, 613, 712, 811, 910, 1009, 1108, 1207, 1306](#) - Thermostat x - Maximum room temperature (1 - Bit - 1.005 DPT_Alarm)

* Default value

Parameter	Description	Value
Object room temperature failure polarity	The Room temperature failure object sends: 0 = No failure, 1 = Failure 0 = Failure, 1 = No failure	Not inverted* Inverted
Object room temperature lower limit alarm polarity	The Minimum room temperature object sends: 0 = no alarm 1 = alarm 0 = alarm 1 = no alarm	Not inverted* Inverted
Object room temperature upper limit alarm polarity	The Maximum room temperature sends: 0 = no alarm 1 = alarm 0 = alarm 1 = no alarm	Not inverted* Inverted

Note: This parameter is only visible if the **Emission room temperature alarm through objects** parameter has the value **Active**.

3.3.10 Emission

To avoid overloading the KNX bus with data transmissions, the device has a section allowing the conditions for transmission of certain objects to be configured.

Setpoint selection

Emission On status change and periodically ▼

Emission period hh:mm:ss

Command value

Emission On status change and periodically ▼

Emission period hh:mm:ss

Value emission by variation of %

Heating/Cooling status indication

Emission On status change and periodically ▼

Emission period hh:mm:ss

* Default value

■ Setpoint selection

Parameter	Description	Value
Emission	The Setpoint selection object is sent: On each change. Periodically after a configurable time. On change and periodically after a configurable time.	On status change* Periodically On status change and periodically

Parameter	Description	Value
Periodical emission	This parameter determines the time between the individual transmissions of the Setpoint selection object.	00:00:01 ... 00:10:00* ... 23:59:59 (hh:mm:ss)

*Note: This parameter is only visible if the **Emission** parameter has the following value **Periodically** or **On status change and periodically**.*

Communication objects:

[183](#), [282](#), [381](#), [480](#), [579](#), [678](#), [777](#), [876](#), [975](#), [1074](#), [1173](#), [1272](#) - Thermostat x - Setpoint selection (1 - Byte - 20.102 DPT_HVACMode)

■ Command value

Parameter	Description	Value
Emission	The ON/OFF and valve position % objects are sent: On each change. Periodically after a configurable time. On change and periodically after a configurable time.	On status change Periodically On status change and periodically*

Parameter	Description	Value
Periodical emission	This parameter determines the time between the individual transmissions of the ON/OFF and Valve position % objects.	00:00:01 ... 00:10:00* ... 23:59:59 (hh:mm:ss)

*Note: This parameter is only visible if the **Emission** parameter has the following value **Periodically** or **On status change and periodically**.*

Parameter	Description	Value
Value emission by variation of	This parameter determines the Dimming value above which the ON/OFF and Valve position % objects are sent.	0 ... 3* ... 100 %

*Note: This parameter is only visible if the **Emission** parameter has the following value **On status change** or **On status change and periodically**.*

Communication objects:

[202, 301, 400, 499, 598, 697, 796, 895, 994, 1093, 1192, 1291](#) - Thermostat x - **ON/OFF** (1 - Bit - 1.001)

[203, 302, 401, 500, 599, 698, 797, 896, 995, 1094, 1193, 1292](#) - Thermostat x - **Valve position in %** (8 - Bit - 5.001 DPT_Scaling)

■ Heating/Cooling status indication

Parameter	Description	Value
Emission	The Heating/Cooling - status indication object is sent: On each change. Periodically after a configurable time. On change and periodically after a configurable time.	On status change* Periodically On status change and periodically

*Note: This parameter is only visible if the **Function selection** parameter has the value **Heating/Cooling** or **Basic and additional heating and cooling**.*

Parameter	Description	Value
Periodical emission	This parameter determines the time between the individual transmissions of the Heating/Cooling - status indication object.	00:00:01 ... 00:10:00* ... 23:59:59 (hh:mm:ss)

*Note: This parameter is only visible if the **Emission** parameter has the following value **Periodically** or **On status change and periodically**.*

Communication objects:

[198, 297, 396, 495, 594, 693, 792, 891, 990, 1089, 1188, 1287](#) - Thermostat x - **Heating/Cooling - status indication** (1 - Bit - 1.100 DPT_Heat_Cool)

* Default value

3.3.11 Setpoints

The product allows setpoint temperatures to be configured which can be preset in the ETS for each operating mode. It is possible to configure absolute setpoint values (independent setpoints) or relative setpoint values (offset from basic setpoint). The setpoint temperatures can also be adjusted during operation using the KNX bus.

i Activate the parameter "Restore ETS-params settings" in General / General so that the parameter value is taken into account after next download.

Setpoints preset
 Relative (offset from basic setpoint)
 Absolute (independent setpoint)

Setpoints heating

Comfort setpoint heating	21	▲▼	°C
Standby setpoint heating	19	▲▼	°C
Night setpoint heating	16	▲▼	°C
Frost protection setpoint heating	7	▲▼	°C

Setpoints cooling

Comfort setpoint cooling	21	▲▼	°C
Standby setpoint cooling	23	▲▼	°C
Night setpoint cooling	26	▲▼	°C
Heat protection setpoint cooling	35	▲▼	°C

Setpoint objects Combined ▼

Difference between basic and additional stages 2 ▲▼ K

Emission On status change ▼

Fahrenheit

Celsius

$$\text{Celsius} = (\text{Fahrenheit} - 32) \cdot \frac{5}{9}$$

Setpoint shift

Save changes permanently

Maximum setpoint 3 ▲▼ K

Minimum setpoint 3 ▲▼ K

Parameter	Description	Value
Setpoints preset	<p>The setpoint temperature is adjusted from a basic setpoint value (Comfort mode). The other setpoint values for the other modes result from this basic setpoint.</p> <p>The setpoint temperatures for the different modes are independent from each other. Different temperature values can be entered in a range from +7.0 °C to +40.0 °C depending on the operating mode and the service mode.</p>	<p>Relative (offset from basic setpoint)</p> <p>Absolute (independent setpoint)*</p>

■ The absolute setpoint values (independent setpoints)

The setpoint temperatures for the different modes are independent from each other. Different temperature values can be entered in a range from +7.0 °C to +40.0 °C depending on the operating mode and the service mode.

Setpoints heating

Comfort setpoint heating	21	▲▼	°C
Standby setpoint heating	19	▲▼	°C
Night setpoint heating	16	▲▼	°C
Frost protection setpoint heating	7	▲▼	°C

Setpoints cooling

Comfort setpoint cooling	21	▲▼	°C
Standby setpoint cooling	23	▲▼	°C
Night setpoint cooling	26	▲▼	°C
Heat protection setpoint cooling	35	▲▼	°C

* Default value

Parameter	Description	Value
Comfort setpoint heating	This parameter defines the setpoint value for the heating comfort mode	7 ... 21* ... 40 °C
Standby setpoint heating	This parameter defines the setpoint temperature for the heating standby mode	7 ... 19* ... 40 °C
Night setpoint heating	This parameter defines the setpoint temperature for the heating night setpoint mode	7 ... 16* ... 40 °C
Frost protection setpoint heating	This parameter defines the setpoint temperature for the heating frost protection mode	7* ... 40 °C

Parameter	Description	Value
Comfort setpoint cooling	This parameter defines the setpoint temperature for the cooling comfort mode	7 ... 21* ... 40 °C
Standby setpoint cooling	This parameter defines the setpoint temperature for the cooling standby mode	7 ... 23* ... 40 °C
Night setpoint cooling	This parameter defines the setpoint temperature for the cooling night setpoint mode	7 ... 26* ... 40 °C
Heat protection setpoint cooling	This parameter defines the setpoint temperature for the heat protection mode for cooling.	7 ... 35* ... 40 °C

■ The relative setpoint values (offset from basic setpoint)

Comfort setpoint	<input type="text" value="21"/>	°C
Standby offset	<input type="text" value="2"/>	K
Night offset	<input type="text" value="5"/>	K
Frost protection setpoint heating	<input type="text" value="7"/>	°C
Heat protection setpoint cooling	<input type="text" value="35"/>	°C
Difference between heating and cooling	<input type="text" value="0"/>	K

Parameter	Description	Value
Comfort setpoint	This parameter defines the temperature taken into account as the basic setpoint value (Comfort mode).	7 ... 21* ... 40 °C
Standby offset	The setpoint temperature in standby mode must be lowered by this value in relation to the heating comfort mode temperature.	1 ... 2* ... 20 K
Night offset	The setpoint temperature in Night setpoint mode must be lowered by this value in relation to the heating comfort mode temperature.	1 ... 5* ... 20 K

Note: In case of cooling, the offset value is added to the comfort mode temperature.

Note: A temperature offset is expressed in Kelvin. 1K of temperature offset corresponds to 1°C.

Parameter	Description	Value
Frost protection setpoint heating	This parameter defines the setpoint temperature for the heating frost protection mode.	7* ... 40 °C

*Note: This parameter is only visible if the **Function selection** parameter has the value **Heating** or **Heating/Cooling** or **Basic and additional heating** or **Basic and additional heating and cooling**.*

Parameter	Description	Value
Heat protection setpoint cooling	This parameter defines the setpoint temperature for the heat protection mode for cooling.	7 ... 35* ... 40 °C

*Note: This parameter is only visible if the **Function selection** parameter has the value **Cooling** or **Heating/Cooling** or **Basic and additional cooling** or **Basic and additional heating and cooling**.*

Parameter	Description	Value
Difference between heating and cooling	The comfort mode setpoint temperatures for heating and cooling result from the basic setpoint value, taking into account a neutral zone to be defined. This parameter defines the value of the neutral zone (temperature zone in which neither the heating or cooling are active) corresponding to the difference between the comfort mode setpoint temperatures for heating and cooling.	0* ... 40 K

*Note: This parameter is only visible if the **Function selection** parameter has the value **Heating/Cooling** or **Basic and additional heating and cooling**.*

Note: A temperature offset is expressed in Kelvin. 1K of temperature offset corresponds to 1°C.

■ Setpoint objects

The setpoint temperatures can also be adjusted during operation using the KNX bus. The list of different objects available to modify the setpoint is shown below.

Parameter	Description	Value
Setpoint objects	The setpoint temperatures are modified using: Several communication objects in 2 byte format corresponding to each setpoint mode. A single communication object in 8 byte format grouping the 4 setpoint modes. The two available formats (2 bytes and 8 bytes)	Simple Combined* Both

Note: The communication objects are available for heating and cooling.

Communication objects: Heating (2 Bytes)

[233, 332, 431, 530, 629, 728, 827, 926, 1025, 1124, 1223, 1322](#) - Thermostat x - Comfort setpoint heating (2 - Byte - 9.001 DPT_Value_Temp)

[234, 333, 432, 531, 630, 729, 828, 927, 1026, 1125, 1224, 1323](#) - Thermostat x - Standby setpoint heating (2 - Byte - 9.001 DPT_Value_Temp)

[235, 334, 433, 532, 631, 730, 829, 928, 1027, 1126, 1225, 1324](#) - Thermostat x - Night setpoint heating (2 - Byte - 9.001 DPT_Value_Temp)

[236, 335, 434, 533, 632, 731, 830, 929, 1028, 1127, 1226, 1325](#) - Thermostat x - Frost protection setpoint heating (2 - Byte - 9.001 DPT_Value_Temp)

* Default value

Communication objects: Heating (8 Bytes)

237, 336, 435, 534, 633, 732, 831, 930, 1029, 1128, 1227, 1326 - Thermostat x - Setpoints heating (8 - Byte - 275.100 DPT_TempRoomSetpSetF16 [4])

Communication objects: Cooling (2 Bytes)

238, 337, 436, 535, 634, 733, 832, 931, 1030, 1129, 1228, 1327 - Thermostat x - Comfort setpoint cooling (2 - Byte - 9.001 DPT_Value_Temp)

239, 338, 437, 536, 635, 734, 833, 932, 1031, 1130, 1229, 1328 - Thermostat x - Standby setpoint cooling (2 - Byte - 9.001 DPT_Value_Temp)

240, 339, 438, 537, 636, 735, 834, 933, 1032, 1131, 1230, 1329 - Thermostat x - Night setpoint cooling (2 - Byte - 9.001 DPT_Value_Temp)

241, 340, 439, 538, 637, 736, 835, 934, 1033, 1132, 1231, 1330 - Thermostat x - Heat protection setpoint cooling (2 - Byte - 9.001 DPT_Value_Temp)

Communication objects: Cooling (8 Bytes)

242, 341, 440, 539, 638, 737, 836, 935, 1034, 1133, 1232, 1331 - Thermostat x - Setpoints cooling (8 - Byte - 275.100 DPT_TempRoomSetpSetF16 [4])

Each communication object has a status indication object used to send the setpoint temperature value.

Communication objects: Heating status indication (2 Bytes)

247, 346, 445, 544, 643, 742, 841, 940, 1039, 1138, 1237, 1336 - Thermostat x - Status indication comfort setpoint heating (2 - Byte - 9.001 DPT_Value_Temp)

248, 347, 446, 545, 644, 743, 842, 941, 1040, 1139, 1238, 1337 - Thermostat x - Status indication standby setpoint heating (2 - Byte - 9.001 DPT_Value_Temp)

249, 348, 447, 546, 645, 744, 843, 942, 1041, 1140, 1239, 1338 - Thermostat x - Status indication night setpoint heating (2 - Byte - 9.001 DPT_Value_Temp)

250, 349, 448, 547, 646, 745, 844, 943, 1042, 1141, 1240, 1339 - Thermostat x - Status indication frost protection setpoint heating (2 - Byte - 9.001 DPT_Value_Temp)

Communication objects: Heating status indication (8 Bytes)

251, 350, 449, 548, 647, 746, 845, 944, 1043, 1142, 1241, 1340 - Thermostat x - Status indication setpoints heating (8 - Byte - 275.100 DPT_TempRoomSetpSetF16 [4])

Communication objects: Cooling status indication (2 Bytes)

252, 351, 450, 549, 648, 747, 846, 945, 1044, 1143, 1242, 1341 - Thermostat x - Status indication comfort setpoint cooling (2 - Byte - 9.001 DPT_Value_Temp)

253, 352, 451, 550, 649, 748, 847, 946, 1045, 1144, 1243, 1342 - Thermostat x - Status indication standby setpoint cooling (2 - Byte - 9.001 DPT_Value_Temp)

254, 353, 452, 551, 650, 749, 848, 947, 1046, 1145, 1244, 1343 - Thermostat x - Status indication night setpoint cooling (2 - Byte - 9.001 DPT_Value_Temp)

255, 354, 453, 552, 651, 750, 849, 948, 1047, 1146, 1245, 1344 - Thermostat x - Cooling frost protection setpoint status indication (2 - Byte - 9.001 DPT_Value_Temp)

Communication objects: Cooling status indication (8 Bytes)

256, 355, 454, 553, 652, 751, 850, 949, 1048, 1147, 1246, 1345 - Thermostat x - Status indication setpoints cooling (8 - Byte - 275.100 DPT_TempRoomSetpSetF16 [4])

Parameter	Description	Value
Emission	The status indication objects for the setpoint temperatures are sent: On each change. Periodically after a configurable time. On change and periodically after a configurable time.	On status change* Periodically On status change and periodically

Parameter	Description	Value
Periodical emission	This parameter determines the time between the individual transmission of the status indication objects for the setpoint temperatures.	00:00:01 ... 00:10:00* ... 23:59:59 (hh:mm:ss)

*Note: This parameter is only visible if the **Emission** parameter has the following value **Periodically** or **On status change and periodically**.*

■ Setpoint shift

The thermostat is used to modify the setpoint temperature per step using the setpoint shift object. The parameters below are used to save or not save this setpoint temperature and limit the setpoint temperature shift.

Parameter	Description	Value
Save changes permanently	Manual modifications of the setpoint value. are taken into account for the duration of the active mode. are validated and saved permanently.	Not active* Active

Parameter	Description	Value
Maximum setpoint	This parameter defines the upper limit of the setpoint temperature shift.	1 ... 3* ... 20 K
Minimum setpoint	This parameter defines the lower limit of the setpoint temperature shift.	1 ... 3* ... 20 K

Note: A temperature offset is expressed in Kelvin. 1K of temperature offset corresponds to 1°C.

Communication objects:

[243](#), [342](#), [441](#), [540](#), [639](#), [738](#), [837](#), [936](#), [1035](#), [1134](#), [1233](#), [1332](#) - Thermostat x - Setpoint shift (2 - Byte - 9.002 DPT_Value_Tempd)

* Default value

3.3.12 Scene

The Scene function is used to switch groups of outputs into a configurable predefined state. A scene is activated by receipt of a 1-byte command. Each thermostat can be integrated into 64 different scenes.

When the scene is activated, the thermostat can switch to one of the following modes:

- Auto
- Comfort
- Standby
- Night setpoint
- Frost/heat protection

i Activate the parameter "Restore ETS-params settings" in General / General so that the parameter value is taken into account after next download.

Scenes memorisation by long key press	<input checked="" type="checkbox"/>	
Number of scenes used	<input type="text" value="8"/>	↑ ↓
Scene 1	<input checked="" type="checkbox"/>	
Scene 1 setpoint		<input type="text" value="Comfort"/>
Scene 2	<input checked="" type="checkbox"/>	
Scene 2 setpoint		<input type="text" value="Comfort"/>
Scene 3	<input checked="" type="checkbox"/>	
Scene 3 setpoint		<input type="text" value="Comfort"/>
Scene 4	<input checked="" type="checkbox"/>	
Scene 4 setpoint		<input type="text" value="Comfort"/>
Scene 5	<input checked="" type="checkbox"/>	
Scene 5 setpoint		<input type="text" value="Comfort"/>
Scene 6	<input checked="" type="checkbox"/>	
Scene 6 setpoint		<input type="text" value="Comfort"/>
Scene 7	<input checked="" type="checkbox"/>	
Scene 7 setpoint		<input type="text" value="Comfort"/>
Scene 8	<input checked="" type="checkbox"/>	
Scene 8 setpoint		<input type="text" value="Comfort"/>

Parameter	Description	Value
Scenes memorisation by very long key press	This parameter allows learning and storing of a scene by, for example, a long press (> 5 seconds) of the corresponding push button.	Active* Not active

* Default value

Learning and storing scenes

This process is used to change and store a scene. For example, by locally pressing the key in the room or by emission of the values from a visualization.

Scene number	Access scene (Object value: 1 byte)	Store scene (Object value: 1 byte)
1-64	= Scene number -1	= Scene number +128
Examples		
1	0	128
2	1	129
3	2	130
...	...	
64	63	191

Here is the scene memorisation for local switches, for example.

- Activate scene by briefly pressing the transmitter that starts it.
- The outputs (lights, shutters, etc.) are set in the desired state using the usual local control devices (buttons, remote control, etc.).
- Memorise the status of the outputs with a press greater than 5 seconds long on the transmitter that starts the scene. The memorisation can be displayed by short-term activation of the outputs.

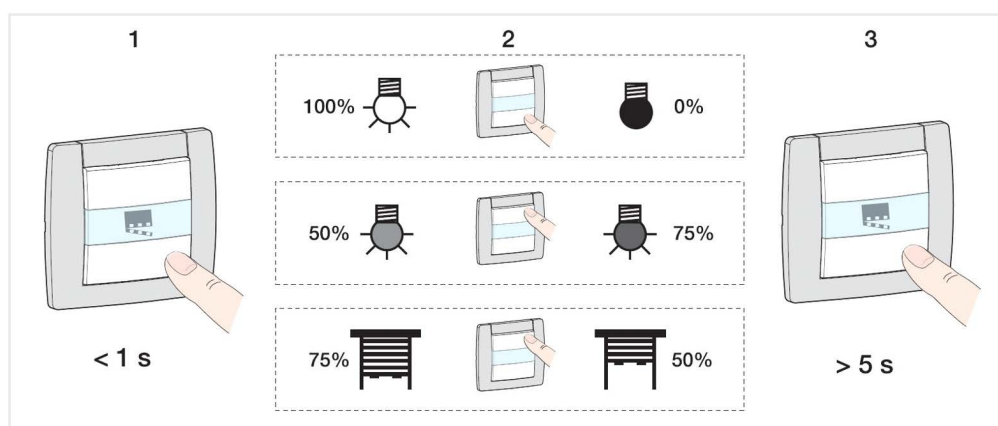

Parameter	Description	Value
Number of scenes used	This parameter determines the number of scenes used.	0 ... 8* ... 64

Note: If the Scene number received on the Scene object is greater than the maximum number of scenes, the status of the output remains unchanged.

* Default value

Parameter	Description	Value
Scene X	On activation of Scene X, the output is: Applies a configurable setpoint. Not changed.	Active* Not active

X = 1 to 64

Note: Each output has up to 64 scenes available, in accordance with the **Number of scenes used** parameter.

Parameter	Description	Value
Scene X setpoint	When scene X is activated, the output applies one of the 5 setpoints.	Auto Comfort* Standby Night setpoint Frost/heat protection

X = 1 to 64

3.3.13 Priority

The Priority function is used to force the thermostat with a defined heating or cooling setpoint. Priority is activated through objects in 1 bit, 2 bit or 1 byte format. Only a Priority OFF command authorizes the output for control.

Priority object format 2 bits ▾

Activation of priority status object Not active Active

Polarity 0 = Not forced, 1 = Forced
 0 = Forced, 1 = Not forced

Emission On status change and periodically ▾

Emission period 00:10:00 hh:mm:ss

Status after priority Theoretical status without priority ▾

Parameter	Description	Value
Priority object format	Priority is carried out using an object below: In standard KNX format (2 bit) 1 bit control Setpoint control (1 byte)	2 bit* 1 bit Setpoint selection

* Default value

■ 1 bit format

Parameter	Description	Value
Priority object polarity	<p>Upon reception of a value on the Priority object, priority:</p> <p>Is active with the value 1. The thermostat changes setpoint according to the Setpoint selection during priority parameter.</p> <p>Is inactive with the value 0. The thermostat changes setpoint according to the Status after priority parameter.</p> <p>Is inactive with the value 1. The thermostat changes setpoint according to the Status after priority parameter.</p> <p>Is active with the value 0. The thermostat changes setpoint according to the Setpoint selection during priority parameter.</p>	<p>1 = Priority active, 0 = Priority not active*</p> <p>1 = Priority not active, 0 = Priority active</p>

*Note: This parameter is only visible if the **Priority object format** parameter has the value **1 bit**.*

Parameter	Description	Value
Setpoint selection during priority	This parameter defines the setpoint value to be applied when priority is active for the thermostat in question.	<p>Comfort*</p> <p>Standby</p> <p>Night setpoint</p> <p>Frost/heat protection</p>

Communication objects:

[192, 291, 390, 489, 588, 687, 786, 885, 984, 1083, 1182, 1281](#) - Thermostat x - Priority (1 Bit) (1 - Bit - 1.011 DPT_State)

■ 2 bit format

Priority is carried out using an object in standard KNX format (2 bit).

Communication objects:

[191, 290, 389, 488, 587, 686, 785, 884, 983, 1082, 1181, 1280](#) - Thermostat x - Priority (2 - Bit - 2.002 DPT_Bool_Control)

■ Setpoint selection

Priority is carried out using an object in 1 byte format receiving a setpoint value. This allows a priority to be activated directly with a desired setpoint value.

Heating mode	Value
Auto	0
Comfort	1
Standby	2
Night setpoint	3
Frost/heat protection	4

The "Auto (0)" setpoint value is used to deactivate the priority.

Communication objects:

[193, 292, 391, 490, 589, 688, 787, 886, 985, 1084, 1183, 1282](#) - Thermostat x - Priority (1 - Byte - 20.102 DPT_HVACMode)

* Default value

Parameter	Description	Value
Status indication priority object	The Status indication priority object is hidden.	Not active*
	The Status indication priority object is hidden.	Active

Communication objects:

[201, 300, 399, 498, 597, 696, 795, 894, 993, 1092, 1191, 1290](#) - **Thermostat x - Status indication priority (1 - Bit - 1.003 DPT_Enable)**

Parameter	Description	Value
Polarity	<p>The Priority mode status indication object sends:</p> <p>0 = on activation of the Priority 1 = on deactivation of the Priority</p> <p>0 = on deactivation of the Priority 1 = on activation of the Priority</p>	<p>0 = Priority active, 1 = Priority not active</p> <p>0 = Priority not active, 1 = Priority active*</p>

*Note: This parameter is only visible if the **Status indication priority object** parameter has the value **Active**.*

Parameter	Description	Value
Emission	<p>The Status indication priority communication object is sent:</p> <p>On activation and deactivation of the Priority.</p> <p>Periodically after a configurable time.</p> <p>On activation and deactivation of the Priority and periodically after a configurable time.</p>	<p>On status change*</p> <p>Periodically</p> <p>On status change and periodically</p>

*Note: This parameter is only visible if the **Activation of priority status object** parameter has the following value **Active**.*

Parameter	Description	Value
Periodicity	This parameter determines the time between the individual transmissions of the Status indication priority object.	00:00:01 ... 00:10:00* ... 23:59:59 (hh:mm:ss)

*Note: This parameter is only visible if the **Emission** parameter has the following value **Periodically** or **On status change and periodically**.*

* Default value

Parameter	Description	Value
Status after priority	At the end of the priority, the thermostat status: Not changed. Switches to Comfort mode. Switches to standby. Switches to night setpoint. Switches to Frost protection/Heat protection mode Switched back to the status before priority was activated Switched to the status which would be active according to other communication objects if the priority had not taken place.	Maintain status Comfort Standby Night setpoint Frost/heat protection Status before priority Theoretical status without priority*

Note: The application of this parameter depends on the priority of the other active functions. If a function with higher priority is active, this parameter will not be enacted. In the case where two functions with the same priority are active, the parameter of the most recently switched off function is enacted.

* Default value

3.3.14 Timer

The Timer function is used to select a heating or cooling setpoint for a configurable duration. The timer may be interrupted before expiry of the delay time. The timer duration can be modified via the bus KNX. When the timing function expires, return to the previous operating mode.

i Activate the parameter "Restore ETS-params settings" in General / General so that the parameter value is taken into account after next download.

Timer operation Comfort ▼

Timer duration 04:00:00 hh:mm:ss

Timer interruption No Yes

Timer retriggerability No Yes

Timer duration extension (10 first seconds) 6 ▼

Timer duration modifiable through object Not active Active

Setpoint selection during timer modifiable through object Not active Active

Parameter	Description	Value
Timer operation	When the timer is activated and for an established duration, the thermostat status: Switches to Comfort mode Switches to standby Switches to night setpoint Switches to Frost protection/Heat protection mode	Comfort* Standby Night setpoint Frost/heat protection

Parameter	Description	Value
Timer duration	This parameter determines the timer duration.	00:00:01 ... 04:00:00* ... 23:59:59 (hh:mm:ss)

Parameter	Description	Value
Timer interruption	On receiving the value 0 on the Timer communication object, the timing is: Interrupted. Not interrupted.	Yes* No

Parameter	Description	Value
Timer retriggerability	The parameter Timer duration extension (10 first seconds) is: Displayed. Hidden.	Yes* No

Parameter	Description	Value
Timer duration extension (10 first seconds)	If, during the first 10 seconds of the timer duration, multiple commands with the value 1 are received on the Timer communication object, it is: Multiplied unlimited times. Multiplied X number of times.	Unlimited 1 ... 6* ... 10

Parameter	Description	Value
Timer duration modifiable through object	The Timer duration communication object is: Hidden. Displayed, the timer duration can be transmitted via the bus.	Not active* Active

Communication objects:

[267, 366, 465, 564, 663, 762, 861, 960, 1059, 1158, 1257, 1356](#) - Thermostat x - Timer duration (3 - Byte - 10.001 DPT_TimeOfDay)

Parameter	Description	Value
Setpoint selection during timer modifiable through object	The Timer setpoint selection object is sent: Hidden. Displayed, the setpoint value can be modified by the bus.	Not active* Active

Communication objects:

[268, 367, 466, 565, 664, 763, 862, 961, 1060, 1159, 1258, 1357](#) - Thermostat x - Setpoint selection during timer (1 - Byte - 20.102 DPT_HVACMode)

* Default value

3.3.15 Preset

The Preset function is used to place a set of thermostats in a configurable predefined status. The Preset function is activated via an object in 1-bit format.

Preset authorization objects	<input type="radio"/> Not active <input checked="" type="radio"/> Active
Value of authorization preset 1 at initialization	Value before initialization ▼
Polarity	<input checked="" type="radio"/> 0 = Locked-up , 1 = Authorized <input type="radio"/> 0 = Authorized, 1 = Locked-up
Value of authorization preset 2 at initialization	Value before initialization ▼
Polarity	<input checked="" type="radio"/> 0 = Locked-up , 1 = Authorized <input type="radio"/> 0 = Authorized, 1 = Locked-up
Status if preset 1 object = 0	Maintain status ▼
Status if preset 1 object = 1	Maintain status ▼
Status if preset 2 object = 0	Maintain status ▼
Status if preset 2 object = 1	Maintain status ▼

Principle of Preset authorization: The parameters are set as follows:

- Polarity of Preset 1 authorization object: 0 = Locked-up, 1 = Authorized.
- Polarity of Preset 2 authorization object: 0 = Locked-up, 1 = Authorized.
- Status if preset 1 object = 0: Night setpoint.
- Status if preset 1 object = 1: Comfort.
- Status if preset 2 object = 0: Scene 1.
- Status if preset 2 object = 1: Scene 2.

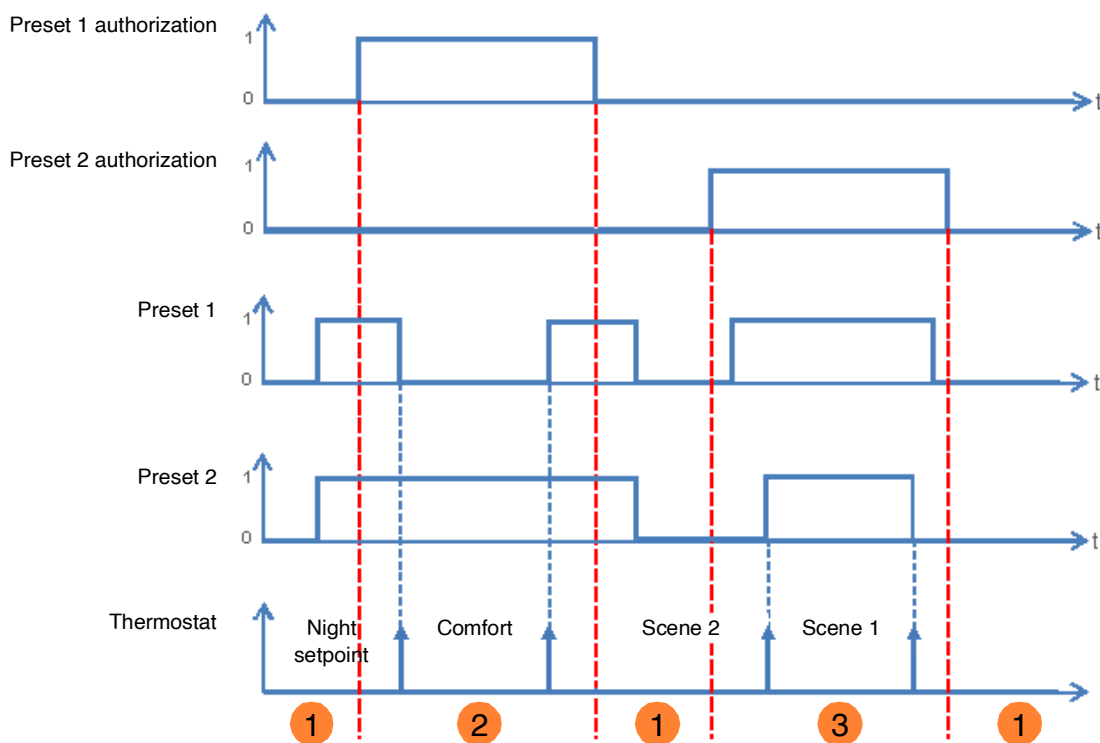

- ❶ The Preset inputs have no effect on the thermostat.
- ❷ The commands from Preset 1 are executed.
- ❸ The commands from Preset 2 are executed.

Note: The commands from the Preset will not be executed immediately after authorization, but only when the value of the Preset changes.

Parameter	Description	Value
Preset authorization objects	The Preset 1 authorization communication object and the related parameters are: Hidden. Displayed. This object allows the authorization or lock-up of the Preset 1 function via a KNX telegram.	Not active* Active

*Note: The number of Preset objects available depends on the **Number of preset objects** parameter. A maximum of two of these objects can be available.*

Communication objects:

[271](#), [370](#), [469](#), [568](#), [667](#), [766](#), [865](#), [964](#), [1063](#), [1162](#), [1261](#), [1360](#) - Thermostat x - Preset 1 authorization (1 - Bit - 1.003 DPT_Enable)

[272](#), [371](#), [470](#), [569](#), [668](#), [767](#), [866](#), [965](#), [1064](#), [1163](#), [1262](#), [1361](#) - Thermostat x - Preset 2 authorization (1 - Bit - 1.003 DPT_Enable)

Note: The parameters and objects are identical for Preset 2 ; Only the terms will be adjusted.

* Default value

Parameter	Description	Value
Value of authorization preset 1 at initialization	On initialization of the device after a download or after return of the bus power, the value of the Preset 1 authorization object is: Set to 0. Set to 1. Set according to the value of the logic input before the initialization occurred.	0 1 Value before initialization*

*Note: This parameter is only visible if the **Preset authorization objects** parameter has the following value **Active**.*

Parameter	Description	Value
Polarity	On receipt of a value on the Preset 1 authorization object, Preset 1 : Locked-up on object value 0. Locked-up on object value 1.	0 = Locked-up, 1 = Authorized* 0 = Authorized, 1 = Locked-up

*Note: This parameter is only visible if the **Preset authorization objects** parameter has the following value **Active**.*

Parameter	Description	Value
Status if preset 1 object = 0	When the value 0 is received on the Preset object 1, the thermostat status, Not changed. Switches to Comfort mode. Switches to standby. Switches to night setpoint. Switches to Frost protection/Heat protection mode. Set to a scene value. Switched to the status that was active before last receiving the value 0 on the Preset 1 object.	Maintain status* Comfort Standby Night setpoint Frost/heat protection Scene number Status before preset 1 = 0

Parameter	Description	Value
Scene	This parameter determines the value of the scene if: The Preset 1 object has value 0. The Status if preset 1 object = 0 object has the scene value.	Scene 1* ... 64

* Default value

Parameter	Description	Value
Status if preset 1 object = 1	<p>When the value 1 is received on the Preset object 1, the thermostat status,</p> <p>Not changed</p> <p>Switches to Comfort mode</p> <p>Switches to standby</p> <p>Switches to night setpoint</p> <p>Switches to Frost protection/Heat protection mode</p> <p>Set to a scene value</p> <p>Switched to the status that was active before last receiving the value 1 on the Preset 1 object</p>	<p>Maintain status*</p> <p>Comfort</p> <p>Standby</p> <p>Night setpoint</p> <p>Frost/heat protection</p> <p>Scene number</p> <p>Status before preset 1 = 0</p>

Parameter	Description	Value
Scene	<p>This parameter determines the value of the scene if:</p> <p>The Preset 1 object has value 1.</p> <p>The Status if preset 1 object = 1 object has the scene value.</p>	Scene 1 ... 2* ... 64

* Default value

3.3.16 Lock-up

The Lock-up function is used to lock a thermostat in a predefined status. The Lock-up prevents actuation until an unlock command has been received. The Lock-up duration can be set.

Lock-up type	<input checked="" type="radio"/> Output lock-up <input type="radio"/> Object lock-up
Lock-up duration	<input type="radio"/> Time limited <input checked="" type="radio"/> Permanently
Polarity of lock-up object 1	<input checked="" type="radio"/> 0 = Lock-up deactivated, 1 = Lock-up activated <input type="radio"/> 0 = Lock-up activated, 1 = Lock-up deactivated
Polarity of lock-up object 2	<input checked="" type="radio"/> 0 = Lock-up deactivated, 1 = Lock-up activated <input type="radio"/> 0 = Lock-up activated, 1 = Lock-up deactivated
Priority between lock-up 1 and lock-up 2	Lock-up 1 > Lock-up 2 ▼
Status if lock-up 1	Maintain status ▼
Status if lock-up 2	Maintain status ▼
Status after lock-up function 1	Maintain status ▼
Status after lock-up function 2	Maintain status ▼
Activation of lock-up status object	<input type="radio"/> Not active <input checked="" type="radio"/> Active
Polarity	<input checked="" type="radio"/> 0 = Lock-up deactivated, 1 = Lock-up activated <input type="radio"/> 0 = Lock-up activated, 1 = Lock-up deactivated
Emission	On status change and periodically ▼
Emission period	00:10:00 hh:mm:ss

Parameter	Description	Value
Lock-up type	The Lock-up acts: Directly controls the thermostat. As long as the Lock-up function is active, the thermostat can only be controlled by higher priority functions. On selected communication objects. As long as the Lock-up function is active, the thermostat can only be controlled by specifically defined objects.	Output lock-up* Object lock-up

* Default value

Parameter	Description	Value
Lock-up duration	The duration of the Lock-up is Not time limited, the lock-up is only authorized by means of a telegram on Lock-up 1 object. Is active for a limited time, the control of the output is authorized after expiry of this time.	Permanently* Time limited

Parameter	Description	Value
Duration	This parameter determines the activation time of the Lock-up.	00:01 ... 00:15* ... 99:59 (hh:mm)

*Note: This parameter is only visible if the **Lock-up duration** parameter has the following value **Time limited**.*

Parameter	Description	Value
Polarity of lock-up object 1	On receipt of a value on the Lock-up 1 object, the lock-up: Is deactivated on object value 0. Is activated on object value 1. Is activated on object value 0. Is deactivated on object value 1.	0 = Lock-up deactivated, 1 = Lock-up activated* 0 = Lock-up activated, 1 = Lock-up deactivated

Note: The parameters and objects are identical for Lock-up 2 ; Only the terms will be adjusted.

Parameter	Description	Value
Priority between lock-up 1 and lock-up 2	The priority between lock-up 1 and lock-up 2 is set as follows: Lock-up 1 has priority over lock-up 2. Lock-up 2 has priority over lock-up 1. Lock-up 1 and lock-up 2 have the same priority.	Lock-up 1 > Lock-up 2* Lock-up 1 < Lock-up 2 Lock-up 1 = Lock-up 2

*Note: This parameter is only visible if the **Lock-up** parameter has the following value **Active with 2 lock-up objects**.*

* Default value

Operating principle of the priorities:

If Lock-up 1 > Lock-up 2

Active lock-up	Activation order of Lock-up 1	Activation order of Lock-up 2
None	Lock-up 1 is activated	Lock-up 2 is activated
Lock-up 1	Lock-up 1 remains active	Despite the activation order of Lock-up 2, Lock-up 1 remains activated
Lock-up 2	Lock-up 1 is activated	Lock-up 2 remains active

If Lock-up 1 = Lock-up 2

Active lock-up	Activation order of Lock-up 1	Activation order of Lock-up 2
None	Lock-up 1 is activated	Lock-up 2 is activated
Lock-up 1	Lock-up 1 remains active	Lock-up 2 is activated
Lock-up 2	Lock-up 1 is activated	Lock-up 2 remains active

If Lock-up 1 < Lock-up 2

Active lock-up	Activation order of Lock-up 1	Activation order of Lock-up 2
None	Lock-up 1 is activated	Lock-up 2 is activated
Lock-up 1	Lock-up 1 remains active	Lock-up 2 is activated
Lock-up 2	Despite the activation order of Lock-up 1, Lock-up 2 remains activated	Lock-up 2 remains active

Parameter	Description	Value
Status if lock-up 1	When Lock-up is activated, the thermostat status: Not changed. Switches to Comfort mode. Switches to standby. Switches to night setpoint. Switches to Frost protection/Heat protection mode	Maintain status* Comfort Standby Night setpoint Frost/heat protection

Note: The parameters and objects are identical for Lock-up 2. only the terms will be adjusted.

* Default value

Lock-up 1 authorizes object:

The parameters listed below allow the selection of the objects for controlling the output via the nevertheless active Lock-up.

*Note: These parameters are only visible if the **Lock-up type** parameter has the following value **Object lock-up**.*

Parameter	Objects concerned	Value
Mode selection	Setpoint selection	Yes No*
Setpoint selection automatic control	Setpoint selection automatic control	Yes No*
Scene	Scene	Yes No*
Preset 1	Preset 1	Yes No*
Preset 2	Preset 2	Yes No*
Setpoint shift	Setpoint shift	Yes No*
Presence/Absence	Presence	Yes No*
Timer	Timer	Yes No*

Note: The parameters and objects are identical for Lock-up 2 ; Only the terms will be adjusted.

Parameter	Description	Value
Status after lock-up function 1	<p>When lock-up is deactivated, the output:</p> <p>Not changed.</p> <p>Switches to Comfort mode.</p> <p>Switches to standby.</p> <p>Switches to night setpoint.</p> <p>Switches to Frost protection/Heat protection mode.</p> <p>Return to the status that was active before the lock-up.</p> <p>Is positioned in the status which would be active if no lock-up control had taken place, taking into account the other active communication objects.</p>	<p>Maintain status*</p> <p>Comfort</p> <p>Standby</p> <p>Night setpoint</p> <p>Frost/heat protection</p> <p>Status before lock-up 1</p> <p>Theoretical status without lock-up function</p>

Note: The application of this parameter depends on the priority of the other active functions. If a function with higher priority is active, this parameter will not be enacted. In the case where two functions with the same priority are active, the parameter of the most recently switched off function is enacted.

Note: The parameters and objects are identical for Lock-up 2 ; Only the terms will be adjusted.

Parameter	Description	Value
Activation of lock-up status object	The Status indication lock-up communication object is hidden.	Not active*
	The Status indication lock-up communication object is displayed.	Active

Communication objects:

[275](#), [374](#), [473](#), [572](#), [671](#), [770](#), [869](#), [968](#), [1067](#), [1166](#), [1265](#), [1364](#) - Thermostat x - Status indication lock-up (1 - Bit - 1.003 DPT_Enable)

Parameter	Description	Value
Polarity	The Status indication Lock-up communication object sends: 0 on deactivation of the lock-up. 1 on activation of the lock-up.	0 = Lock-up deactivated, 1 = Lock-up activated*
	0 on activation of the lock-up. 1 on deactivation of the lock-up.	0 = Lock-up activated, 1 = Lock-up deactivated

Parameter	Description	Value	
Emission	The Status indication lock-up communication object is sent:	On status change*	
	On activation and deactivation of the lock-up.		Periodically
	Periodically after a configurable time.		On status change and periodically
	On activation and deactivation of the lock-up and periodically after a configurable time.		

*Note: This parameter is only visible if the **Activation of Lock-up status object** parameter has the following value **Active**.*

Parameter	Description	Value
Periodicity	This parameter determines the time between the individual transmissions of the Status indication lock-up object.	00:00:01 ... 00:10:00* ... 23:59:59 (hh:mm:ss)

*Note: This parameter is only visible if the **Emission** parameter has the following value **Periodically** or **On status change and periodically**.*

4 Communication objects

4.1 Communication objects General

	Number	Name	Function of the object	Length	C	R	W	T
	163	General	Summer/winter mode changeover	1 bit	C	R	W	-
	164	General	Summer/winter changeover date	3 byte	C	R	W	-
	165	General	Winter/summer changeover date	3 byte	C	R	W	-
	166	General	Valves operating voltage failure	1 bit	C	R	-	T
	167	General	Reset short circuit/overload	1 bit	C	R	W	-
	168	General	Heat requirement	1 bit	C	R	-	T
	169	General	External heat requirement	1 bit	C	R	W	-
	170	General	Largest command value	1 byte	C	R	-	T
	171	General	External largest command value	1 byte	C	R	W	-
	172	General	Service mode	2 bit	C	R	W	-
	173	General	Status indication service mode	1 bit	C	R	-	T
	174	General	Pump ON/OFF	1 bit	C	R	-	T
	175	General	External pump control	1 bit	C	R	W	-
	176	General	Pump protection date	3 byte	C	R	W	-
	177	General	Pump protection time	3 byte	C	R	W	-
	178	General	Pump protection date and time	8 byte	C	R	W	-
	179	General	Pump protection duration	2 byte	C	R	W	-
	180	General	Pump protection periodicity	2 byte	C	R	W	-
	181	General	Pump protection start/stop	1 bit	C	R	W	-
	182	General	Heating activation	1 bit	C	R	W	-
	1371	Logic block 1	Authorization	1 bit	C	R	W	-
	1372	Logic block 1	Input 1	1 bit	C	R	W	-
	1373	Logic block 1	Input 2	1 bit	C	R	W	-
	1374	Logic block 1	Input 3	1 bit	C	R	W	-
	1375	Logic block 1	Input 4	1 bit	C	R	W	-
	1376	Logic block 1	Logic result	1 bit	C	R	-	T
	1377	Logic block 2	Authorization	1 bit	C	R	W	-
	1378	Logic block 2	Input 1	1 bit	C	R	W	-
	1379	Logic block 2	Input 2	1 bit	C	R	W	-
	1380	Logic block 2	Input 3	1 bit	C	R	W	-
	1381	Logic block 2	Input 4	1 bit	C	R	W	-
	1382	Logic block 2	Logic result	1 bit	C	R	-	T

	Number	Name	Function of the object	Length	C	R	W	T
	1383	General	Date	3 byte	C	R	W	-
	1384	General	Time	3 byte	C	R	W	-
	1385	General	Date and time	8 byte	C	R	W	-
	1386	General	Date and time request	1 bit	C	R	-	T
	1387	General	Deactivation of manual mode	1 bit	C	R	W	-
	1388	General	Status indication manual mode	1 bit	C	R	-	T
	1389	General	Restore ETS-params settings	1 bit	C	R	W	-
	1390	General	Device LED switch off	1 bit	C	R	W	-
	1391	General	Diagnosis	6 byte	C	R	-	T

4.1.1 Summer/winter mode

No.	Name	Function of the object	Data type	Flags
163	General	Summer/winter mode changeover	1 - Bit - 1.001 DPT_Switch	C, R, W

This object is activated if the **Summer/winter changeover mode** parameters have the value **Through object**. This object is used to control the summer and winter mode by the KNX bus.

Object value: Depends on the **Polarity** parameter.

1 = Summer, 0 = Winter

- If the object receives the value 1, summer mode is activated.
- If the object receives the value 0, winter mode is activated.

1 = Winter, 0 = Summer

- If the object receives the value 1, winter mode is activated.
- If the object receives the value 0, summer mode is activated.

For further information, see: [Summer/winter mode](#).

No.	Name	Function of the object	Data type	Flags
164	General	Summer/winter changeover date	3 - Byte - 11.01 DPT_Date	C, R, W

This object is activated if the **Summer/winter changeover mode** parameters have the value **By date**. This object is used to receive the reference date for the changeover from summer mode to winter mode.

Object value:

Byte 3 (MSB)					Byte 2				Byte 1 (LSB)															
Day									Year															
0	0	0	D	D	D	D	D	0	0	0	0	0	M	M	M	M	0	Y	Y	Y	Y	Y	Y	Y

Fields	Code	Value	Units
Day	Binary	1 to 31 (5 bit)	Day
Month	Binary	1 to 12 (4 bit)	Month
Year	Binary	0 to 99 (7 bit)	Year

For further information, see: [Summer/winter mode](#).

No.	Name	Function of the object	Data type	Flags
165	General	Winter/summer changeover date	3 - Byte - 11.01 DPT_Date	C, R, W

This object is activated if the **Summer/winter changeover mode** parameters have the value **By date**. This object is used to receive the reference date for changeover from winter mode to summer mode.

Object value:

Byte 3 (MSB)					Byte 2					Byte 1 (LSB)													
Day					Month					Year													
0	0	0	D	D	D	D	D	0	0	0	0	M	M	M	M	0	Y	Y	Y	Y	Y	Y	Y

Fields	Code	Value	Units
Day	Binary	1 to 31 (5 bit)	Day
Month	Binary	1 to 12 (4 bit)	Month
Year	Binary	0 to 99 (7 bit)	Year

For further information, see: [Summer/winter mode](#).

4.1.2 Short circuit/Overload status indication

No.	Name	Function of the object	Data type	Flags
166	General	Valves operating voltage failure	1 - Bit - 1.005 DPT_Alarm	C, R, T

This object is activated when the **Valves operating voltage failure object** is active. This object is used to report a valve output service voltage failure (24V or 230V) for the device on the KNX bus.

Object value: Depends on the **Polarity** parameter.

1 = Failure, 0 = No failure

- If a voltage fault is detected, a telegram with a logic value 1 is sent.
- If no voltage fault is detected, a telegram with a logic value 0 is sent.

1 = No failure, 0 = Failure

- If no voltage fault is detected, a telegram with a logic value 1 is sent.
- If a voltage fault is detected, a telegram with a logic value 0 is sent.

This object is sent periodically and/or on status change.

For further information, see: [Short circuit/Overload status indication](#).

No.	Name	Function of the object	Data type	Flags
167	General	Reset short circuit/overload	1 - Bit - 1.002 DPT_Bool	C, R, W

This object is activated when the **Short circuit/overload reset object** is active.

This object is used for the general reset of all the valve output short circuit and overload messages from the KNX bus.

Object value:

- If the object receives the value 0, no action is taken.
- If the object receives the value 1, all the messages are reset.

The messages can only be reset if the control cycle (test cycle duration and waiting time) for the valve outputs in question is finished.

For further information, see: [Short circuit/Overload status indication](#).

4.1.3 Heat requirement

No.	Name	Function of the object	Data type	Flags
168	General	Heat requirement	1 - Bit - 1.002 DPT_Bool	C, R, T
<p>This object is activated when the Heat requirement parameter is active.</p> <p>This object is used to send a heat requirement from the device on the KNX bus. A heat requirement is indicated by the product only if one of the configured values for the assigned outputs exceeds one of the limit values defined with added hysteresis. Cancellation of a heat requirement message occurs as soon as the value falls below the limit value.</p> <p>Object value: Depends on the Polarity parameter.</p> <p>1 = Heat requirement, 0 = No heat requirement</p> <ul style="list-style-type: none"> - If the heat requirement is inactive, a telegram with a logic value 0 is sent. - If the heat requirement is active, a telegram with a logic value 1 is sent. <p>1 = No heat requirement, 0 = Heat requirement</p> <ul style="list-style-type: none"> - If the heat requirement is inactive, a telegram with a logic value 1 is sent. - If the heat requirement is active, a telegram with a logic value 0 is sent. <p>This object is sent periodically and/or on status change.</p> <p>For further information, see: Heat requirement.</p>				

No.	Name	Function of the object	Data type	Flags
169	General	External heat requirement	1 - Bit - 1.002 DPT_Bool	C, R, W
<p>This object is activated when the External heat requirement parameter is active.</p> <p>This object is used to receive a heat requirement control by the KNX bus for the cascading of several products.</p> <p>Object value:</p> <p>1 = Heat requirement, 0 = No heat requirement</p> <ul style="list-style-type: none"> - If the object receives the value 1, the heat requirement is active. - If the object receives the value 0, the heat requirement is inactive. <p><i>Note: The polarity of this object is not configurable.</i></p> <p>For further information, see: Heat requirement.</p>				

4.1.4 Largest command value

No.	Name	Function of the object	Data type	Flags
170	General	Largest command value	8 - Bit - 5.001 DPT_Scaling	C, R, T
<p>This object is active when the Largest command value parameter is active.</p> <p>This object is used to send the largest command value for the valve outputs on the KNX bus. This value is sent to another connected device on the bus to optimise the energy consumption of a building.</p> <p>Object value: 0 (0%) to 255 (100%).</p> <p><i>Note: The Largest command value function is only available for valve outputs controlled using an object in 1 byte format. Only continuous command values (1 byte) are accounted.</i></p> <p>For further information, see: Largest command value.</p>				

No.	Name	Function of the object	Data type	Flags
171	General	External largest command value	8 - Bit - 5.001 DPT_Scaling	C, R, W
<p>This object is activated when the External largest command value parameter is active.</p> <p>This object is used to receive the largest command value for the valve outputs by the KNX bus for the cascading of several products.</p> <p>Object value: 0 (0%) to 255 (100%).</p> <p>For further information, see: Largest command value.</p>				

4.1.5 Service mode

No.	Name	Function of the object	Data type	Flags
172	General	Service mode	2 - Bit - 2.001 DPT_Switch_Control	C, R, W

This object is activated when the **Service mode** parameter is active.
This object is used to activate and deactivate the device service mode on the KNX bus.

Details on the format of the object are given below.

Telegram received on the Service mode object			Output behaviour
Hexadecimal Value	Binary Value		
		BIT1 (MSB)	BIT0 (LSB)
00	0	0	Service mode deactivated
01	0	1	Service mode deactivated
02	1	0	Service mode activated, valves closed
03	1	1	Service mode activated, valves open

Bit 1 of the telegram activates service mode with the value 1. The valve outputs assigned are then locked in the status predefined by bit 0 (0 = closed and 1 = open). The value 0 in bit 1 deactivates service mode again.

For further information, see: [Service mode](#).

No.	Name	Function of the object	Data type	Flags
173	General	Status indication service mode	1 Bit - 1.002 DPT_Bool	C, R, T

This object is activated when the **Service mode** parameter is active.
This object is used to send the status of the device service mode on the KNX bus.

Object value: Depends on the **Polarity** parameter.

1 = Service mode not active, 0 = Service mode active

- If service mode is deactivated, a telegram with a logic value 1 is sent.
- If service mode is activated, a telegram with a logic value 0 is sent.

1 = Service mode active, 0 = Service mode not active

- If service mode is activated, a telegram with a logic value 1 is sent.
- If service mode is deactivated, a telegram with a logic value 0 is sent.

This object is sent periodically and/or on status change.

For further information, see: [Service mode](#).

4.1.6 Pump control

No.	Name	Function of the object	Data type	Flags
174	General	Pump ON/OFF	1 - Bit - 1.001 DPT_Switch	C, R, T
<p>This object is activated when the Pump control parameter is active. This object is used to send a pump control for the device on the KNX bus for the direct control of a heating or cooling circulation pump. The pump is activated by the product only if one of the configured values for the assigned outputs exceeds one of the defined limit values with the addition of the hysteresis. Pump deactivation occurs as soon as the value falls below the limit value.</p> <p>Object value: Depends on the Polarity parameter. 1 = Pump OFF, 0 = Pump ON</p> <ul style="list-style-type: none"> - If the pump is deactivated, a telegram with a logic value 1 is sent. - If the pump is activated, a telegram with a logic value 0 is sent. <p>1 = Pump ON, 0 = Pump OFF</p> <ul style="list-style-type: none"> - If the pump is activated, a telegram with a logic value 1 is sent. - If the pump is deactivated, a telegram with a logic value 0 is sent. <p>For further information, see: Pump control.</p>				

No.	Name	Function of the object	Data type	Flags
175	General	External pump control	1 - Bit - 1.001 DPT_Switch	C, R, W
<p>This object is activated when the External pump control parameter is active. This object is used to send a pump control by the KNX bus for several products mounted in cascade.</p> <p>Object value: 1 = Pump ON, 0 = Pump OFF</p> <ul style="list-style-type: none"> - If the object receives the value 1, the pump is active. - If the object receives the value 0, the pump is inactive. <p><i>Note: The polarity of this object is not configurable.</i></p> <p>For further information, see: Pump control.</p>				

4.1.7 Pump protection

No.	Name	Function of the object	Data type	Flags
176	General	Pump protection date	3 - Byte - 11.001 DPT_Date	C, R, W

This object is activated when the **Pump protection** parameter is active and when the **Pump protection activation** parameter has the value **Periodically at specific time**.

This object is used to define the device pump protection date by the KNX bus.

Object value:

Byte 3 (MSB)					Byte 2				Byte 1 (LSB)														
Day					Month				Year														
0	0	0	D	D	D	D	D	0	0	0	0	M	M	M	M	0	Y	Y	Y	Y	Y	Y	Y

Fields	Code	Value	Units
Day	Binary	1 to 31 (5 bit)	Day
Month	Binary	1 to 12 (4 bit)	Month
Year	Binary	0 to 99 (7 bit)	Year

For further information, see: [Pump protection](#).

No.	Name	Function of the object	Data type	Flags
177	General	Pump protection time	3 - Byte - 10.001 DPT_TimeOfDay	C, R, W

This object is activated when the **Pump protection** parameter is active and when the **Pump protection activation** parameter has the value **Periodically at specific time**.

This object is used to define the device pump protection time by the KNX bus.

Object value:

Byte 3 (MSB)				Byte 2				Byte 1 (LSB)															
Day		Hours		Minutes				Seconds															
D	D	D	T	T	T	T	T	0	0	M	M	M	M	M	M	0	0	W	W	W	W	W	W

Fields	Code	Value	Units
Day	Binary	0 = Any day 1 = Monday ... 7 = Sunday (3 bit)	
Hours	Binary	0 to 23 (5 bit)	Hours
Minutes	Binary	0 to 59 (6 bit)	Minutes
Seconds	Binary	0 to 59 (6 bit)	Seconds

For further information, see: [Pump protection](#).

No.	Name	Function of the object	Data type	Flags
178	General	Pump protection date and time	8 - Byte - 19.001 DPT_DateTime	C, R, W

This object is activated when the **Pump protection** parameter is active and when the **Pump protection activation** parameter has the value **Periodically at specific time**.

This object is used to define the device protection date and time by the KNX bus.

Object value:

Byte 8 (MSB)								Byte 7				Byte 6				Byte 5																
Year								Month				Day of the month				Weekday		Hours														
Y	Y	Y	Y	Y	Y	Y	Y	0	0	0	0	M	M	M	M	0	0	0	0	D	D	D	D	D	D	D	D	D	T	T	T	T

Byte 4				Byte 3				Byte 2						Byte 1 (LSB)																					
Minutes				Seconds				D	DW	DW	YV	DV	WD	TV	SW	CA																			
0	0	M	M	M	M	M	M	0	0	W	W	W	W	W	W	B	B	B	B	B	B	B	B	B	B	B	B	0	0	0	0	0	0	0	0

Fields	Code	Value	Units
Year	Binary	0 (1900) to 255 (2155) (8 bit)	Year
Month	Binary	1 to 12 (4 bit)	Month
Day of the month	Binary	1 to 31 (5 bit)	Day
Day of the week	Binary	0 = Any day	
	Binary	1 = Monday ... 7 = Sunday (3 bit)	
Hours	Binary	0 to 23 (5 bit)	Hours
Minutes	Binary	0 to 59 (6 bit)	Minutes
Seconds	Binary	0 to 59 (6 bit)	Seconds
Error (D)	Binary	0 = No error or 1 = Error (1 bit)	
Day Worked (DW)	Binary	0 = Day Worked or 1 = Holiday (1 bit)	
DWV (DWV)	Binary	0 = Day Worked valid or 1 = Invalid DW (1 bit)	
Year Validated (YV)	Binary	0 = Year valid or 1 = Invalid year (1 bit)	
DV (DV)	Binary	0 = Date valid or 1 = Invalid date (1 bit)	
Weekday validated (WDV)	Binary	0 = Day valid or 1 = Invalid day (1 bit)	
Time Validated (TV)	Binary	0 = Time valid or 1 = Invalid time (1 bit)	
Summer/Winter Period (SWP)	Binary	0 = standard time or 1 = Summertime (1 bit)	
Clock Accuracy (CA)	Binary	0 = No external synchronisation or	

For further information, see: [Pump protection](#).

No.	Name	Function of the object	Data type	Flags
179	General	Pump protection duration	2 - Byte - 7.006 DPT_TimePeriodMin	C, R, W
<p>This object is active when the Pump protection parameter is active. This object is used to define the device pump protection duration by the KNX bus.</p> <p>Object value: 0 min ... 65 535 min (Corresponds to approximately 45.5 days) Units: minute Resolution: 1 min</p> <p>For further information, see: Pump protection.</p>				

No.	Name	Function of the object	Data type	Flags
180	General	Pump protection periodicity	2 - Byte - 7.007 DPT_TimePeriodHrs	C, R, W
<p>This object is activated when the Pump protection parameter is active and when the Pump protection activation parameter has the value Periodically or Periodically at specific time. This object is used to define the device pump protection periodicity by the KNX bus.</p> <p>Object value: 0 h ... 65 535 h (Corresponds to approximately 7.4 years) Units: time Resolution: 1 h</p> <p>For further information, see: Pump protection.</p>				

No.	Name	Function of the object	Data type	Flags
181	General	Pump protection start/stop	1 - Bit - 1.010 DPT_Start	C, R, W
<p>This object is activated when the Pump protection parameter is active and when the Pump protection activation parameter has the value Through object. This object is used to control pump protection activation by the KNX bus.</p> <p>Object value: Depends on the Polarity parameter.</p> <p>1 = Start, 0 = Stop</p> <ul style="list-style-type: none"> - If the object receives the value 1, pump protection starts. - If the object receives the value 0, pump protection stops. <p>1 = Stop, 0 = Start</p> <ul style="list-style-type: none"> - If the object receives the value 1, pump protection stops. - If the object receives the value 0, pump protection starts. <p>For further information, see: Pump protection.</p>				

4.1.8 Heating activation

No.	Name	Function of the object	Data type	Flags
182	General	Heating activation	1 - Bit - 1.001 DPT_Switch	C, R, W
<p>These objects are always activated. This object is used to control the activation and deactivation of all the valve outputs at the same time by the KNX bus.</p> <p>Object value: Depends on the Polarity parameter. 1 = Heating activ., 0 = Heating deactiv.</p> <ul style="list-style-type: none"> - If the object receives the value 1, all the valve outputs are active. The outputs operate normally. - If the object receives the value 0, all the valve outputs are deactivated. The value of the outputs switches to 0%. <p>1 = Heating deactiv., 0 = Heating activ.</p> <ul style="list-style-type: none"> - If the object receives the value 1, all the valve outputs are deactivated. The value of the outputs switches to 0%. - If the object receives the value 0, all the valve outputs are active. The outputs operate normally. <p>For further information, see: Heating activation.</p>				

4.1.9 Logic block

No.	Name	Function of the object	Data type	Flags
1371	Logic block 1	Authorization	1 Bit - 1.003 DPT_Enable	C, R, W
<p>This object is activated if the Logic block 1 parameter and the Lock-up logic block object are active. This object makes it possible to activate or deactivate the logic blocks of the device via the KNX bus.</p> <p>Object value: Depends on the Polarity parameter. 0 = Locked-up, 1 = Authorized</p> <ul style="list-style-type: none"> - If the object receives the value 0, logic block 1 is deactivated. - If the object receives the value 1, logic block 1 is activated. <p>0 = Authorized, 1 = Locked-up</p> <ul style="list-style-type: none"> - If the object receives the value 0, logic block 1 is activated. - If the object receives the value 1, logic block 1 is deactivated. <p>The value of this object can be initialized at start-up of the device. For further information, see: Logic block.</p>				

No.	Name	Function of the object	Data type	Flags
1372	Logic block 1	Input 1	1 Bit - 1.002 DPT_Bool	C, R, W
1373	Logic block 1	Input 2	1 Bit - 1.002 DPT_Bool	C, R, W
1374	Logic block 1	Input 3	1 Bit - 1.002 DPT_Bool	C, R, W
1375	Logic block 1	Input 4	1 Bit - 1.002 DPT_Bool	C, R, W

These objects are activated in accordance with the value of the **Number of logic inputs** parameter. There may be up to a maximum of 4 of these objects.
 These objects are used to produce the status of a logic input for processing of the logic operation.
 The value of these objects can be initialized at start-up of the device.

For further information, see: [Logic block](#).

No.	Name	Function of the object	Data type	Flags
1376	Logic block 1	Logic result	1 Bit - 1.002 DPT_Bool	C, R, T

This object is activated when the **Logic block 1** parameter is active.
 This object enables output of the results of the logic operation via the bus.
 The value of the object is the result of a logic AND or OR operation, according to the status of the logic inputs.
 There may be up to a maximum of 4 of these objects. This result can also be directly assigned to the status of the output contact.

For further information, see: [Logic block](#).

No.	Name	Function of the object	Data type	Flags
1377	Logic block 2	Authorization	1 Bit - 1.003 DPT_Enable	C, R, W

See object No. 1371

No.	Name	Function of the object	Data type	Flags
1378	Logic block 2	Input 1	1 Bit - 1.002 DPT_Bool	C, R, W
1379	Logic block 2	Input 2	1 Bit - 1.002 DPT_Bool	C, R, W
1380	Logic block 2	Input 3	1 Bit - 1.002 DPT_Bool	C, R, W
1381	Logic block 2	Input 4	1 Bit - 1.002 DPT_Bool	C, R, W

See object No. 1372

No.	Name	Function of the object	Data type	Flags
1382	Logic block 2	Logic result	1 Bit - 1.002 DPT_Bool	C, R, T

See object No. 1376

4.1.10 Date and time format

No.	Name	Function of the object	Data type	Flags																																																																																						
1383	General	Date	3 - Byte - 11.01 DPT_Date	C, R, W																																																																																						
<p>This object is activated if the Date and time objects parameter has the value 2 objects (3 Bytes + 3 Bytes). This object receives the reference date of an external device.</p> <p>Object value:</p> <table border="1"> <thead> <tr> <th colspan="5">Byte 3 (MSB)</th> <th colspan="4">Byte 2</th> <th colspan="4">Byte 1 (LSB)</th> </tr> <tr> <td></td><td></td><td></td><td colspan="2">Day</td> <td></td><td></td><td></td><td></td> <td colspan="4">Month</td> <td colspan="4">Year</td> </tr> <tr> <td>0</td><td>0</td><td>0</td><td>D</td><td>D</td><td>D</td><td>D</td><td>D</td> <td>0</td><td>0</td><td>0</td><td>0</td> <td>M</td><td>M</td><td>M</td><td>M</td> <td>0</td><td>Y</td><td>Y</td><td>Y</td><td>Y</td><td>Y</td><td>Y</td><td>Y</td> </tr> </thead> <tbody> <tr> <td colspan="2">Fields</td> <td colspan="2">Code</td> <td colspan="2">Value</td> <td colspan="2">Units</td> </tr> <tr> <td colspan="2">Day</td> <td colspan="2">Binary</td> <td colspan="2">1 to 31 (5 bit)</td> <td colspan="2">Day</td> </tr> <tr> <td colspan="2">Month</td> <td colspan="2">Binary</td> <td colspan="2">1 to 12 (4 bit)</td> <td colspan="2">Month</td> </tr> <tr> <td colspan="2">Year</td> <td colspan="2">Binary</td> <td colspan="2">0 to 99 (7 bit)</td> <td colspan="2">Year</td> </tr> </tbody> </table> <p><i>Note: As a basic time is required to trigger the pump protection function, a reference date and time are necessary for operation.</i></p> <p>For further information, see: Date and time format.</p>					Byte 3 (MSB)					Byte 2				Byte 1 (LSB)							Day						Month				Year				0	0	0	D	D	D	D	D	0	0	0	0	M	M	M	M	0	Y	Y	Y	Y	Y	Y	Y	Fields		Code		Value		Units		Day		Binary		1 to 31 (5 bit)		Day		Month		Binary		1 to 12 (4 bit)		Month		Year		Binary		0 to 99 (7 bit)		Year	
Byte 3 (MSB)					Byte 2				Byte 1 (LSB)																																																																																	
			Day						Month				Year																																																																													
0	0	0	D	D	D	D	D	0	0	0	0	M	M	M	M	0	Y	Y	Y	Y	Y	Y	Y																																																																			
Fields		Code		Value		Units																																																																																				
Day		Binary		1 to 31 (5 bit)		Day																																																																																				
Month		Binary		1 to 12 (4 bit)		Month																																																																																				
Year		Binary		0 to 99 (7 bit)		Year																																																																																				

No.	Name	Function of the object	Data type	Flags																																																																																						
1384	General	Time	3 - Byte - 10.01 DPT_TimeOfDay	C, R, W																																																																																						
<p>This object is activated if the Date and time objects parameter has the value 2 objects (3 Bytes + 3 Bytes). This object receives the reference date of an external device.</p> <p>Object value:</p> <table border="1"> <thead> <tr> <th colspan="5">Byte 3 (MSB)</th> <th colspan="4">Byte 2</th> <th colspan="4">Byte 1 (LSB)</th> </tr> <tr> <td></td><td></td><td></td><td colspan="2">Day</td> <td></td><td></td><td></td><td></td> <td colspan="4">Month</td> <td colspan="4">Year</td> </tr> <tr> <td>0</td><td>0</td><td>0</td><td>D</td><td>D</td><td>D</td><td>D</td><td>D</td> <td>0</td><td>0</td><td>0</td><td>0</td> <td>M</td><td>M</td><td>M</td><td>M</td> <td>0</td><td>Y</td><td>Y</td><td>Y</td><td>Y</td><td>Y</td><td>Y</td><td>Y</td> </tr> </thead> <tbody> <tr> <td colspan="2">Fields</td> <td colspan="2">Code</td> <td colspan="2">Value</td> <td colspan="2">Units</td> </tr> <tr> <td colspan="2">Day</td> <td colspan="2">Binary</td> <td colspan="2">1 to 31 (5 bit)</td> <td colspan="2">Day</td> </tr> <tr> <td colspan="2">Month</td> <td colspan="2">Binary</td> <td colspan="2">1 to 12 (4 bit)</td> <td colspan="2">Month</td> </tr> <tr> <td colspan="2">Year</td> <td colspan="2">Binary</td> <td colspan="2">0 to 99 (7 bit)</td> <td colspan="2">Year</td> </tr> </tbody> </table> <p><i>Note: As a basic time is required to trigger the pump protection function, a reference date and time are necessary for operation.</i></p> <p>For further information, see: Date and time format.</p>					Byte 3 (MSB)					Byte 2				Byte 1 (LSB)							Day						Month				Year				0	0	0	D	D	D	D	D	0	0	0	0	M	M	M	M	0	Y	Y	Y	Y	Y	Y	Y	Fields		Code		Value		Units		Day		Binary		1 to 31 (5 bit)		Day		Month		Binary		1 to 12 (4 bit)		Month		Year		Binary		0 to 99 (7 bit)		Year	
Byte 3 (MSB)					Byte 2				Byte 1 (LSB)																																																																																	
			Day						Month				Year																																																																													
0	0	0	D	D	D	D	D	0	0	0	0	M	M	M	M	0	Y	Y	Y	Y	Y	Y	Y																																																																			
Fields		Code		Value		Units																																																																																				
Day		Binary		1 to 31 (5 bit)		Day																																																																																				
Month		Binary		1 to 12 (4 bit)		Month																																																																																				
Year		Binary		0 to 99 (7 bit)		Year																																																																																				

No.	Name	Function of the object	Data type	Flags
1385	General	Date and time	8 - Byte - 19.001 DPT_DateTime	C, R, W

This object is activated if the **Date and time objects** parameter has the value **1 object (8 Bytes)**.
This object receives the reference date and time of an external device.

Object value:

Byte 8 (MSB)								Byte 7				Byte 6				Byte 5																
Year								Month				Day of the month				Weekday		Hours														
Y	Y	Y	Y	Y	Y	Y	Y	0	0	0	0	M	M	M	M	0	0	0	0	D	D	D	D	D	D	D	D	D	T	T	T	T

Byte 4								Byte 3				Byte 2				Byte 1 (LSB)															
Minutes								Seconds				D	DW	DW	YV	DV	WD	TV	SW	CA											
0	0	M	M	M	M	M	M	0	0	W	W	W	W	W	W	B	B	B	B	B	B	B	B	B	0	0	0	0	0	0	0

Fields	Code	Value	Units
Year	Binary	0 (1900) to 255 (2155) (8 bit)	Year
Month	Binary	1 to 12 (4 bit)	Month
Day of the month	Binary	1 to 31 (5 bit)	Day
Day of the week	Binary	0 = Any day	
	Binary	1 = Monday ... 7 = Sunday (3 bit)	
Hours	Binary	0 to 23 (5 bit)	Hours
Minutes	Binary	0 to 59 (6 bit)	Minutes
Seconds	Binary	0 to 59 (6 bit)	Seconds
Error (D)	Binary	0 = No error or 1 = Error (1 bit)	
Day Worked (DW)	Binary	0 = Day Worked or 1 = Holiday (1 bit)	
DWV (DWV)	Binary	0 = Day Worked valid or 1 = Invalid DW (1 bit)	
Year Validated (YV)	Binary	0 = Year valid or 1 = Invalid year (1 bit)	
DV (DV)	Binary	0 = Date valid or 1 = Invalid date (1 bit)	
Weekday validated (WDV)	Binary	0 = Day valid or 1 = Invalid day (1 bit)	
Time Validated (TV)	Binary	0 = Time valid or 1 = Invalid time (1 bit)	
Summer/Winter Period (SWP)	Binary	0 = standard time or 1 = Summertime (1 bit)	
Clock Accuracy (CA)	Binary	0 = No external synchronisation or	

Note: As a basic time is required to trigger the pump protection function, a reference date and time are necessary for operation.

For further information, see: [Date and time format](#).

No.	Name	Function of the object	Data type	Flags
1386	General	Date and time request	1 - Bit - 1.017 DPT_Trigger	C, R, T

These objects are always activated.

This object is used to send a reference date and time request from the product on the KNX bus.

Object value:

- If a date and time request is received, a telegram with the logical value 1 is sent.

For further information, see: [Date and time format](#).

4.1.11 Manual mode

No.	Name	Function of the object	Data type	Flags
1387	General	Deactivation of manual mode	1 - Bit - 1.003 DPT_Enable	C, R, W
<p>This object is activated if the Manual mode parameter and the Deactivation of manual mode object are active. This object is used to control the manual mode via the KNX bus.</p> <p>Object value: Depends on the Polarity parameter.</p> <p>0 = Manual mode locked-up, 1 = Manual mode authorized</p> <ul style="list-style-type: none"> - If the object receives the value 1, manual mode is activated. - If the object receives the value 0, manual mode is deactivated. <p>0 = Manual mode authorized, 1 = Manual mode locked-up</p> <ul style="list-style-type: none"> - If the object receives the value 1, manual mode is deactivated. - If the object receives the value 0, manual mode is activated. <p>For further information, see: Manual mode.</p>				

No.	Name	Function of the object	Data type	Flags
1388	General	Status indication manual mode	1 - Bit - 1.003 DPT_Enable	C, R, T
<p>This object is activated if the Manual mode parameter and the Deactivation of manual mode object are active. This object is used to control the manual mode via the KNX bus.</p> <p>Object value: Depends on the Polarity parameter.</p> <p>0 = Manual mode activated, 1 = Manual mode deactivated</p> <ul style="list-style-type: none"> - If manual mode is deactivated, a telegram is sent with logic value 1. - If manual mode is activated, a telegram is sent with logic value 0. <p>0 = Manual mode deactivated, 1 = Manual mode activated</p> <ul style="list-style-type: none"> - If manual mode is activated, a telegram is sent with logic value 1. - If manual mode is deactivated, a telegram is sent with logic value 0. <p>This object is sent periodically and/or on status change.</p> <p>For further information, see: Manual mode.</p>				

4.1.12 Behaviour of the device

No.	Name	Function of the object	Data type	Flags
1389	General	Restore ETS-params settings	1 - Bit - 1.001 DPT_Switch	C, R, W
<p>This object is activated if the Activ. of restore ETS-parameters object (scenes, timer, setpoints) parameter is active.</p> <p>This object enables the current parameter value to be replaced at any time with the ETS parameter value.</p> <p>If the object receives value 1, then the output status values for the scenes, the timer duration specifications and all the counter setpoints are reset to the values sent by the last download.</p> <p>For further information, see: Restore ETS-Parameters.</p>				

No.	Name	Function of the object	Data type	Flags
1390	General	Device LED switch off	1 Bit - 1.001 DPT_Switch	C, R, W
<p>This object is activated if the Device LED lock-up object parameter is active.</p> <p>This function is used to reduce the overall power consumption of the device. It allows the LEDs on the front of the device to be switched off.</p> <p>Object value: Depends on the Polarity parameter.</p> <p>0 = Status indication, 1 = Always OFF</p> <ul style="list-style-type: none"> - If the object receives value 0, the LED display is activated. - If the object receives value 1, the LED display is deactivated. <p>0 = Always OFF, 1 = Status indication</p> <ul style="list-style-type: none"> - If the object receives value 0, the LED display is deactivated. - If the object receives value 1, the LED display is activated. <p>For further information, see: LED display.</p>				

4.1.13 Diagnosis

No.	Name	Function of the object	Data type	Flags																		
1391	General	Diagnosis	6 Byte - Specific	C, R, T																		
<p>This object is activated when the Device diagnosis object parameter is active.</p> <p>The object enables reporting of current faults according to the device and the application used. It also allows sending of the position of the switch on the front of the device and the number of the output that is affected by the fault(s).</p> <table border="1" style="width: 100%; border-collapse: collapse;"> <thead> <tr> <th>Byte number</th> <th>6 (MSB)</th> <th colspan="3">5</th> <th>4</th> <th>3</th> <th>2</th> <th>1 (LSB)</th> </tr> </thead> <tbody> <tr> <td>Use</td> <td>Switch position</td> <td>Application type</td> <td>Output number</td> <td colspan="5">Error codes</td> </tr> </tbody> </table> <p>This object is sent periodically and/or on status change.</p> <p>For further information, see: Diagnosis.</p>					Byte number	6 (MSB)	5			4	3	2	1 (LSB)	Use	Switch position	Application type	Output number	Error codes				
Byte number	6 (MSB)	5			4	3	2	1 (LSB)														
Use	Switch position	Application type	Output number	Error codes																		

4.2 Output communication objects

	Number	Name	Function of the object	Length	C	R	W	T
	1	Output 1	ON/OFF	1 bit	C	R	W	-
	2	Output 1	Valve position in %	1 byte	C	R	W	-
	3	Output 1	Status indication ON/OFF	1 bit	C	R	-	T
	4	Output 1	Status valve position in %	1 byte	C	R	-	T
	5	Output 1	Command value monitoring failure	1 bit	C	R	-	T
	6	Output 1	Short circuit/Overload status indication	1 bit	C	R	-	T
	7	Output 1	Priority	2 bit	C	R	W	-
	8	Output 1	Priority (1 Bit)	1 bit	C	R	W	-
	9	Output 1	Status indication priority	1 bit	C	R	-	T
	10	Output 1	Heating/Cooling - changeover	1 bit	C	R	W	-
	11	Output 1	Command value limitation activation	1 bit	C	R	W	-
	12	Output 1	Hours counter value (h)	2 byte	C	R	-	T
	13	Output 1	Hours counter value (s)	4 byte	C	R	-	T
	14	Output 1	Reset hours counter value	1 bit	C	R	W	-
	15	Output 1	Hours counter setpoint reached	1 bit	C	R	-	T
	16	Output 1	Hours counter setpoint (h)	2 byte	C	R	W	-
	17	Output 1	Hours counter setpoint (s)	4 byte	C	R	W	-
	18	Output 1	Valve protection date	3 byte	C	R	W	-
	19	Output 1	Valve protection time	3 byte	C	R	W	-
	20	Output 1	Valve protection date and time	8 byte	C	R	W	-
	21	Output 1	Valve protection duration	2 byte	C	R	W	-
	22	Output 1	Valve protection periodicity	1 byte	C	R	W	-
	23	Output 1	Valve protection start/stop	1 bit	C	R	W	-
	24	Output 1	Lock-up 1	1 bit	C	R	W	-
	25	Output 1	Lock-up 2	1 bit	C	R	W	-
	26	Output 1	Status indication lock-up	1 bit	C	R	-	T
	27	Output 1	Room temperature failure	1 bit	C	R	W	-

Note: The designation of the objects is identical for the other outputs. Only the object number differs.

4.2.1 Switching

No.	Name	Function of the object	Data type	Flags
1, 28, 55, 82, 109, 136	Output x	ON/OFF	1 - Bit - 1.001 DPT_Switch	C, R, W
<p>These objects are always activated.</p> <p>This object is used to switch the valve output contact according to the value sent on the KNX bus. This value can come from a KNX room thermostat for example.</p> <p>Object value: It depends on the Default valve status parameter.</p> <p>Normally open On reception of an OFF control, the valve is powered and closes. On reception of an ON control, the valve is not powered and opens.</p> <p>Normally closed On reception of an OFF control, the valve is not powered and closes. On reception of an ON control, the valve is powered and opens.</p> <p>For further information, see: Control/Status/Operating mode.</p>				

No.	Name	Function of the object	Data type	Flags
2, 29, 56, 83, 110, 137	Output x	Valve position in %	8 - Bit - 5.001 DPT_Scaling	C, R, W
<p>These objects are always activated.</p> <p>This object is used to control the valve outputs according to the value in % sent on the KNX bus. This value can come from a KNX room thermostat for example.</p> <p>Object value: 0 (0%) to 255 (100%).</p> <p><i>Note: This object is only available if the Command value format parameter has the value continous with pwm (1 byte) or ON/OFF with command value (1 byte). The valve output will be controlled according to the value received.</i></p> <p>For further information, see: Control/Status/Operating mode.</p>				

4.2.2 Status indication

No.	Name	Function of the object	Data type	Flags
3, 30, 57, 84, 111, 138	Output x	Status indication ON/OFF	1 - Bit - 1.001 DPT_Switch	C, R, T

This object is activated when the **Status indication** parameter is active. This object is used to send the valve output contact status for the device on the KNX bus.

Object value:
0 = valve closed, 1 = valve open

- If the valve is open, a telegram with the logic value 1 is sent on the KNX bus.
- If the valve is closed, a telegram with the logic value 0 is sent on the KNX bus.

This object is sent periodically and/or on status change.

For further information, see: [Control/Status/Operating mode](#).

No.	Name	Function of the object	Data type	Flags
4, 31, 58, 85, 112, 139	Output x	Status valve position in %	8 - Bit - 5.001 DPT_Scaling	C, R, T

This object is activated when the **Status indication** parameter is active. This object is used to send the value in % of the device valve output on the KNX bus.

Object value: 0 (0%) to 255 (100%) .

This object is sent periodically and/or on status change.

For further information, see: [Control/Status/Operating mode](#).

No.	Name	Function of the object	Data type	Flags
5, 32, 59, 86, 113, 140	Output x	Command value monitoring failure	1 - Bit - 1.005 DPT_Alarm	C, R, T

This object is activated when the **Command value monitoring** parameter is active. This object is used to send a notification of a Command value monitoring failure concerning the device's valve outputs on the KNX bus.

Object value:
1 = Failure, 0 = No failure

- If a command value monitoring fault is detected, a telegram with a logic value 1 is sent.
- if no command value monitoring fault is detected, a telegram with a logic value 0 is sent.

This object is sent periodically and/or on status change.

*Note: the setting for the transmission of this object, valid for all the outputs is adjusted in the **General - Status valve outputs** tab of the device.*

For further information, see: [Control/Status/Operating mode](#).

No.	Name	Function of the object	Data type	Flags
6, 33, 60, 87, 114, 141	Output x	Short circuit/Overload status indication	1 - Bit - 1.005 DPT_Alarm	C, R, T

This object is activated when the **Short circuit/Overload status indication** parameter is active. This object is used to send a notification of a short circuit or overload concerning the device's valve outputs on the KNX bus.

Object value:
 If a short circuit or overload is detected for the valve outputs in question, a telegram with a logic value 1 is sent on the object.
 This object is sent periodically and/or on status change.

*Note: the setting for the transmission of this object, valid for all the outputs is adjusted in the **General - Status valve outputs** tab of the device.*

For further information, see: [Control/Status/Operating mode](#).

4.2.3 Priority

No.	Name	Function of the object	Data type	Flags
7, 34, 61, 88, 115, 142	Output x	Priority	2 - Bit - 2.002 DPT_Bool_Control	C, R, W

This object is activated if the **Priority object format** parameters have the value **2 bit**. The status of the valve outputs is directly determined by this object.

Details on the format of the object are given below.

Telegram received by the priority operation object			Output behaviour
Hexadecimal Value	Binary Value		
	BIT1 (MSB)	BIT0 (LSB)	
00	0	0	End of the priority
01	0	1	End of the priority
02	1	0	Priority, valves closed
03	1	1	Priority, valves open

Bit 1 of the telegram activates priority with the value 1. The valve outputs assigned are then locked in the status predefined by bit 0 (0 = closed and 1 = open). The value 0 in bit 1 deactivates priority again.

For further information, see: [Control/Status/Operating mode](#).

No.	Name	Function of the object	Data type	Flags
8, 35, 62, 89, 116, 143	Output x	Priority (1 Bit)	1 - Bit - 1.003 DPT_Enable	C, R, W
<p>This object is activated if the Priority object format parameters have the value 1 bit. This object is used to activate or deactivate priority mode for the device on the KNX bus.</p> <p>Object value: Depends on the Polarity parameter. 1 = Priority active, 0 = Priority not active</p> <ul style="list-style-type: none"> - If the object receives the value 1, priority is active. The output is positioned according to the Command value when priority active parameter. - If the object receives the value 0, priority is inactive. The output is positioned at the value present before priority was activated. <p>1 = Priority not active, 0 = Priority active</p> <ul style="list-style-type: none"> - If the object receives the value 0, priority is active. The output is positioned according to the Command value when priority active parameter. - If the object receives the value 1, priority is inactive. The output is positioned at the value present before priority was activated. <p>For further information, see: Control/Status/Operating mode.</p>				

No.	Name	Function of the object	Data type	Flags
9, 36, 63, 90, 117, 144	Output x	Status indication priority	1 - Bit - 1.003 DPT_Enable	C, R, T
<p>This object is activated when the Status indication priority object parameter is active and the Priority object format parameter has the value 1 bit or 2 bit. This object allows the status of the Priority to be sent from the device on the KNX bus.</p> <p>Object value: Depends on the Polarity parameter. 1 = Priority not active, 0 = Priority active</p> <ul style="list-style-type: none"> - If Priority is activated, a telegram is sent with logic value 0. - If Priority is deactivated, a telegram is sent with logic value 1. <p>1 = Priority active, 0 = Priority not active</p> <ul style="list-style-type: none"> - If Priority is deactivated, a telegram is sent with logic value 0. - If Priority is activated, a telegram is sent with logic value 1. <p>This object is sent periodically and/or on status change. For further information, see: Control/Status/Operating mode.</p>				

No.	Name	Function of the object	Data type	Flags
10, 37, 64, 91, 118, 145	Output x	Heating/Cooling - changeover	1 - Bit - 1.100 DPT_Heat_Cool	C, R, W
<p>These objects are always activated. This object is used to switch the heating mode to cooling and the reverse according to the value sent on the KNX bus. This value can come from a KNX room thermostat for example.</p> <p>Object value:</p> <ul style="list-style-type: none"> - If the object receives the value 1, heating mode is active. - If the object receives the value 0, cooling mode is active. <p>For further information, see: Control/Status/Operating mode.</p>				

No.	Name	Function of the object	Data type	Flags
11, 38, 65, 92, 119, 146	Output x	Command value limitation activation	1 - Bit - 1.003 DPT_Enable	C, R, W
<p>This object is activated if the Command value limitation parameter has the value Through object. This object is used to activate command value limitation for the device according to the value sent on the KNX bus.</p> <p>Object value:</p> <ul style="list-style-type: none"> - If the object receives the value 1, command value limitation is active. - If the object receives the value 0, command value limitation is inactive. <p><i>Note: This object is only available if the Command value format parameter has the value Continuous with PWM (1 byte).</i></p> <p>For further information, see: Control/Status/Operating mode.</p>				

4.2.4 Hours counter

No.	Name	Function of the object	Data type	Flags
12, 39, 66, 93, 120, 147	Output x	Hours counter value (h)	2 - Byte - 7.007 DPT_TimePeriodHrs	C, R, T
<p>This object is activated when the Hours counter parameter is active and when the Hours counter objects unit parameter has the value Hours. This object allows the value of the operating hours to be sent from the device on the KNX bus. The count value is saved during a power cut on the KNX bus. It is submitted after return of power to the bus or after an ETS download.</p> <p>Object value: 0 to 65535 hours (corresponds approximately to 7.4 years) This object is sent periodically and/or on status change.</p> <p>For further information, see: Hours counter.</p>				

No.	Name	Function of the object	Data type	Flags
13, 40, 67, 94, 121, 148	Output x	Hours counter value (s)	4 - Byte - 13.100 DPT_LongDeltaTimeSec	C, R, T
<p>This object is activated when the Hours counter parameter is active and when the Hours counter objects unit parameter has the value Seconds. This object allows the value of the operating hours to be sent from the device on the KNX bus. The count value is saved during a power cut on the KNX bus. It is submitted after return of power to the bus or after an ETS download.</p> <p>Object value: 0 to 2 147 483 647 seconds (corresponds approximately to 68 years) This object is sent periodically and/or on status change.</p> <p>For further information, see: Hours counter.</p>				

No.	Name	Function of the object	Data type	Flags
14, 41, 68, 95, 122, 149	Output x	Reset hours counter value	1 - Bit - 1.015 DPT_Reset	C, R, W
<p>This object is activated when the Hours counter parameter is active. This object enables the hours counter value to be reset.</p> <p>Object value:</p> <ul style="list-style-type: none"> - If the object receives the value 0, the counter is not reset.. - If the object receives the value 1, the counter is reset. <p>For further information, see: Hours counter.</p>				

No.	Name	Function of the object	Data type	Flags
15, 42, 69, 96, 123, 150	Output x	Hours counter setpoint reached	1 - Bit - 1.011 DPT_State	C, R, T
<p>This object is activated when the Hours counter parameter is active. This object reports that the hours counter has reached its setpoint.</p> <ul style="list-style-type: none"> - Incrementing counter: Counter = Counter value setpoint - Countdown counter: Counter = 0 <p>Object value: If the setpoint is reached, a telegram with logic value 1 is sent on the KNX bus. The count value is saved during a power cut on the KNX bus. It is submitted after return of power to the bus or after an ETS download. This object is sent periodically and/or on status change.</p> <p>For further information, see: Hours counter.</p>				

No.	Name	Function of the object	Data type	Flags
16, 43, 70 97, 124, 151	Output x	Hours counter setpoint (h)	2 - Byte - 7.007 DPT_TimePeriodHrs	C, R, W
<p>This object is activated if the Counter setpoint value modifiable through object parameter is active and when the Hours counter objects unit parameter has the value Hours. This object is used to initialize the counter setpoint of the hours counter via the KNX bus.</p> <p>Object value: 0 to 65535 hours This object is sent periodically and/or on status change.</p> <p>For further information, see: Hours counter.</p>				

No.	Name	Function of the object	Data type	Flags
17, 44, 71, 98, 125, 152	Output x	Hours counter setpoint (s)	4 - Byte - 13.100 DPT_LongDeltaTimeSec	C, R, W
<p>This object is activated if the Counter setpoint value modifiable through object parameter is active and when the Hours counter objects unit parameter has the value Seconds. This object is used to initialize the counter setpoint of the hours counter via the KNX bus.</p> <p>Object value: 0 to 65535 hours This object is sent periodically and/or on status change.</p> <p>For further information, see: Hours counter.</p>				

4.2.5 Valve protection

No.	Name	Function of the object	Data type	Flags
18, 45, 72, 99, 126, 153	Output x	Valve protection date	3 - Byte - 11.01 DPT_Date	C, R, W

This object is activated when the **Valve protection** parameter is active and the **Valve protection activation** parameter has the value **Periodically at specific time**.

This object is used to define the valve protection date for the device by the KNX bus.

Object value:

Byte 3 (MSB)					Byte 2					Byte 1 (LSB)													
Day					Month					Year													
0	0	0	D	D	D	D	D	0	0	0	0	M	M	M	M	0	Y	Y	Y	Y	Y	Y	Y

Fields	Code	Value	Units
Day	Binary	1 to 31 (5 bit)	Day
Month	Binary	1 to 12 (4 bit)	Month
Year	Binary	0 to 99 (7 bit)	Year

For further information, see: [Valve protection](#).

No.	Name	Function of the object	Data type	Flags
19, 46, 73, 100, 127, 154	Output x	Valve protection time	3 - Byte - 10.01 DPT_TimeOfDay	C, R, W

This object is activated when the **Valve protection** parameter is active and the **Valve protection activation** parameter has the value **Periodically at specific time**.

This object is used to define the valve protection time for the device by the KNX bus.

Object value:

Byte 3 (MSB)					Byte 2					Byte 1 (LSB)													
Day			Hours		Minutes					Seconds													
D	D	D	T	T	T	T	T	0	0	M	M	M	M	M	M	0	0	W	W	W	W	W	W

Fields	Code	Value	Units
Day	Binary	0 = Any day 1 = Monday ... 7 = Sunday (3 bit)	
Hours	Binary	0 to 23 (5 bit)	Hours
Minutes	Binary	0 to 59 (6 bit)	Minutes
Seconds	Binary	0 to 59 (6 bit)	Seconds

For further information, see: [Valve protection](#).

No.	Name	Function of the object	Data type	Flags
20, 47, 74, 101, 128, 154	Output x	Valve protection date and time	8 - Byte - 19.001 DPT_DateTime	C, R, W

This object is activated when the **Valve protection** parameter is active and the **Valve protection activation** parameter has the value **Periodically at specific time**.

This object is used to define the valve protection date and time for the device by the KNX bus.

Object value:

Byte 8 (MSB)								Byte 7				Byte 6				Byte 5																
Year								Month				Day of the month				Weekday		Hours														
Y	Y	Y	Y	Y	Y	Y	Y	0	0	0	0	M	M	M	M	0	0	0	0	D	D	D	D	D	D	D	D	D	T	T	T	T

Byte 4				Byte 3				Byte 2				Byte 1 (LSB)																			
Minutes				Seconds				D	DW	DW	YV	DV	WD	TV	SW	CA															
0	0	M	M	M	M	M	M	0	0	W	W	W	W	W	W	B	B	B	B	B	B	B	B	B	0	0	0	0	0	0	0

Fields	Code	Value	Units
Year	Binary	0 (1900) to 255 (2155) (8 bit)	Year
Month	Binary	1 to 12 (4 bit)	Month
Day of the month	Binary	1 to 31 (5 bit)	Day
Day of the week	Binary	0 = Any day	
	Binary	1 = Monday ... 7 = Sunday (3 bit)	
Hours	Binary	0 to 23 (5 bit)	Hours
Minutes	Binary	0 to 59 (6 bit)	Minutes
Seconds	Binary	0 to 59 (6 bit)	Seconds
Error (D)	Binary	0 = No error or 1 = Error (1 bit)	
Day Worked (DW)	Binary	0 = Day Worked or 1 = Holiday (1 bit)	
DWV (DWV)	Binary	0 = Day Worked valid or 1 = Invalid DW (1 bit)	
Year Validated (YV)	Binary	0 = Year valid or 1 = Invalid year (1 bit)	
DV (DV)	Binary	0 = Date valid or 1 = Invalid date (1 bit)	
Weekday validated (WDV)	Binary	0 = Day valid or 1 = Invalid day (1 bit)	
Time Validated (TV)	Binary	0 = Time valid or 1 = Invalid time (1 bit)	
Summer/Winter Period (SWP)	Binary	0 = standard time or 1 = Summertime (1 bit)	
Clock Accuracy (CA)	Binary	0 = No external synchronisation or	

For further information, see: [Valve protection](#).

No.	Name	Function of the object	Data type	Flags
21, 48, 75, 102, 129, 156	Output x	Valve protection duration	2 - Byte - 7.006 DPT_TimePeriodMin	C, R, W
<p>This object is activated when the Valve protection parameter is active. This object is used to define the valve protection duration for the device by the KNX bus.</p> <p>Object value: 0 min ... 65 535 min (Corresponds to approximately 45.5 days) Units: minute Resolution: 1 min</p> <p>For further information, see: Valve protection.</p>				

No.	Name	Function of the object	Data type	Flags
22, 49, 76, 103, 130, 157	Output x	Valve protection periodicity	2 - Byte - 7.007 DPT_TimePeriodHrs	C, R, W
<p>This object is activated when the Valve protection parameter is active and the Valve protection activation parameter has the value Periodically or Periodically at specific time. This object is used to define the valve protection periodicity for the device by the KNX bus.</p> <p>Object value: 0 h ... 65 535 h (Corresponds to approximately 7.4 years) Units: time Resolution: 1 h</p> <p>For further information, see: Valve protection.</p>				

No.	Name	Function of the object	Data type	Flags
23, 50, 77, 104, 131, 158	Output x	Valve protection start/stop	1 - Bit - 1.010 DPT_Start	C, R, W
<p>This object is activated when the Valve protection parameter is active and the Valve protection activation parameter has the value Through object. This object is used to control activation of valve protection for the valve outputs in question by the KNX bus. It depends on the Pump protection start/stop object polarity parameter.</p> <p>Object value:</p> <p>1 = Start, 0 = Stop</p> <ul style="list-style-type: none"> - If the object receives the value 1, valve protection starts. - If the object receives the value 0, valve protection stops. <p>1 = Stop, 0 = Start</p> <ul style="list-style-type: none"> - If the object receives the value 1, valve protection stops. - If the object receives the value 0, valve protection starts. <p>For further information, see: Valve protection.</p>				

No.	Name	Function of the object	Data type	Flags
24, 51, 78, 105, 132, 159	Output x	Lock-up 1	1 - Bit - 1.003 DPT_Enable	C, R, W
<p>This object is activated if the Lock-up parameter has the value Active with 1 lock-up object or Active with 2 lock-up objects.</p> <p>This object is used to control the activation of the lock-up via the KNX bus.</p> <p>Object value: This is dependent on the Polarity of lock-up object 1 parameter.</p> <p>0 = Lock-up activated, 1 = Lock-up deactivated</p> <ul style="list-style-type: none"> - If the object receives value 0, the Lock-up is activated. - If the object receives value 1, the Lock-up is deactivated. <p>0 = Lock-up deactivated, 1 = Lock-up activated</p> <ul style="list-style-type: none"> - If the object receives value 0, the Lock-up is deactivated. - If the object receives value 1, the Lock-up is activated. <p>For further information, see: Lock-up.</p>				

































No.	Name	Function of the object	Data type	Flags
25, 52, 79, 106, 133, 160	Output x	Lock-up 2	1 - Bit - 1.003 DPT_Enable	C, R, W
<p>This object is activated if the Lock-up parameter has the value Active with 2 lock-up objects.</p> <p>See object No. 24.</p>				

No.	Name	Function of the object	Data type	Flags
26, 53, 80, 107, 134, 161	Output x	Status indication lock-up	1 - Bit - 1.003 DPT_Enable	C, R, T
<p>This object is activated when the Activation of lock-up status object parameter is active.</p> <p>This object allows the status of the lock-up to be sent from the device over the KNX bus.</p> <p>Object value: Depends on the Polarity parameter.</p> <p>0 = Lock-up deactivated, 1 = Lock-up activated</p> <ul style="list-style-type: none"> - If the lock-up is deactivated, a telegram with logic value 0 is sent on the KNX bus. - If the lock-up is activated, a telegram with logic value 1 is sent on the KNX bus. <p>0 = Lock-up activated, 1 = Lock-up deactivated</p> <ul style="list-style-type: none"> - If the lock-up is activated, a telegram with logic value 0 is sent on the KNX bus. - If the lock-up is deactivated, a telegram with logic value 1 is sent on the KNX bus. <p>This object is sent periodically and/or on status change.</p> <p>For further information, see: Lock-up.</p>				

No.	Name	Function of the object	Data type	Flags
27, 54, 81, 108, 135, 162	Output x	Room temperature failure	1 - Bit - 1.005 DPT_Alarm	C, R, W
<p>These objects are always activated.</p> <p>This object is used to control the valve outputs to emergency mode following a room temperature failure. This value can come from a KNX room thermostat for example.</p> <p>Object value:</p> <p>If the object receives the value 1, the output in question will be positioned in emergency mode.</p> <p>If the object receives the value 0, the output is repositioned to the status before the failure.</p> <p>For further information, see: Control/Status/Operating mode.</p>				

4.3 Communications objects per thermostat

This chapter is only valid for reference TYMS646R.

	Number	Name	Function of the object	Length	C	R	W	T
	183	Thermostat 1	Setpoint selection	1 byte	C	R	W	-
	184	Thermostat 1	Comfort	1 bit	C	R	W	-
	185	Thermostat 1	Standby mode	1 bit	C	R	W	-
	186	Thermostat 1	Night setpoint	1 bit	C	R	W	-
	187	Thermostat 1	Frost/heat protection	1 bit	C	R	W	-
	188	Thermostat 1	Setpoint selection automatic control	1 byte	C	R	W	-
	189	Thermostat 1	Automatic control deactivation	1 bit	C	R	W	-
	190	Thermostat 1	Heating/Cooling - changeover	1 bit	C	R	W	-
	191	Thermostat 1	Priority	2 bit	C	R	W	-
	192	Thermostat 1	Priority (1 Bit)	1 bit	C	R	W	-
	193	Thermostat 1	Priority	1 byte	C	R	W	-
	194	Thermostat 1	Windows contact	1 bit	C	R	W	-
	195	Thermostat 1	Scene	1 byte	C	R	W	-
	196	Thermostat 1	Status indication setpoint selection	1 byte	C	R	-	T
	197	Thermostat 1	Automatic control deactivation status	1 bit	C	R	-	T
	198	Thermostat 1	Heating/Cooling - status indication	1 bit	C	R	-	T
	199	Thermostat 1	Status indication heating active	1 bit	C	R	-	T
	200	Thermostat 1	Status indication cooling active	1 bit	C	R	-	T
	201	Thermostat 1	Status indication priority	1 bit	C	R	-	T
	202	Thermostat 1	ON/OFF	1 bit	C	R	-	T
	203	Thermostat 1	Valve position in %	1 byte	C	R	-	T
	204	Thermostat 1	ON/OFF - basic cooling	1 bit	C	R	-	T
	205	Thermostat 1	Valve position in % - basic cooling	1 byte	C	R	-	T
	206	Thermostat 1	ON/OFF - additional heating	1 bit	C	R	-	T
	207	Thermostat 1	Valve position in % - additional heating	1 byte	C	R	-	T
	208	Thermostat 1	ON/OFF - additional cooling	1 bit	C	R	-	T
	209	Thermostat 1	Valve position in % - additional cooling	1 byte	C	R	-	T
	210	Thermostat 1	Room temperature 1	2 byte	C	R	W	-
	211	Thermostat 1	Room temperature 2	2 byte	C	R	W	-
	212	Thermostat 1	Room temperature 3	2 byte	C	R	W	-
	213	Thermostat 1	Floor temperature	2 byte	C	R	W	-
	214	Thermostat 1	Status indication room temperature	2 byte	C	R	-	T

	Number	Name	Function of the object	Length	C	R	W	T
	215	Thermostat 1	Room temperature failure	1 bit	C	R	-	T
	216	Thermostat 1	Minimum room temperature	1 bit	C	R	-	T
	217	Thermostat 1	Maximum room temperature	1 bit	C	R	-	T
	218	Thermostat 1	Ventilation automatic/manual mode	1 bit	C	R	W	-
	219	Thermostat 1	Status ventilation step 1-6	1 byte	C	R	W	-
	220	Thermostat 1	Status ventilation step 1	1 bit	C	R	W	-
	221	Thermostat 1	Status ventilation step 2	1 bit	C	R	W	-
	222	Thermostat 1	Status ventilation step 3	1 bit	C	R	W	-
	223	Thermostat 1	Status ventilation step 4	1 bit	C	R	W	-
	224	Thermostat 1	Status ventilation step 5	1 bit	C	R	W	-
	225	Thermostat 1	Status ventilation step 6	1 bit	C	R	W	-
	226	Thermostat 1	Ventilation step 1-6	1 byte	C	R	-	T
	227	Thermostat 1	Ventilation step 1	1 bit	C	R	-	T
	228	Thermostat 1	Ventilation step 2	1 bit	C	R	-	T
	229	Thermostat 1	Ventilation step 3	1 bit	C	R	-	T
	230	Thermostat 1	Ventilation step 4	1 bit	C	R	-	T
	231	Thermostat 1	Ventilation step 5	1 bit	C	R	-	T
	232	Thermostat 1	Ventilation step 6	1 bit	C	R	-	T
	233	Thermostat 1	Comfort setpoint heating	2 byte	C	R	W	-
	234	Thermostat 1	Standby setpoint heating	2 byte	C	R	W	-
	235	Thermostat 1	Night setpoint heating	2 byte	C	R	W	-
	236	Thermostat 1	Frost protection setpoint heating	2 byte	C	R	W	-
	237	Thermostat 1	Setpoints heating	8 byte	C	R	W	-
	238	Thermostat 1	Comfort setpoint cooling	2 byte	C	R	W	-
	239	Thermostat 1	Standby setpoint cooling	2 byte	C	R	W	-
	240	Thermostat 1	Night setpoint cooling	2 byte	C	R	W	-
	241	Thermostat 1	Heat protection setpoint cooling	2 byte	C	R	W	-
	242	Thermostat 1	Setpoints cooling	8 byte	C	R	W	-
	243	Thermostat 1	Setpoint shift	2 byte	C	R	W	-
	244	Thermostat 1	Current setpoint	2 byte	C	R	W	-
	245	Thermostat 1	Status indication setpoint shift	2 byte	C	R	-	T
	246	Thermostat 1	Status indication reference setpoint	2 byte	C	R	-	T

	Number	Name	Function of the object	Length	C	R	W	T
	247	Thermostat 1	Status indication comfort setpoint heating	2 byte	C	R	-	T
	248	Thermostat 1	Status indication standby setpoint heating	2 byte	C	R	-	T
	249	Thermostat 1	Status indication night setpoint heating	2 byte	C	R	-	T
	250	Thermostat 1	Status indication frost protection setpoint heating	2 byte	C	R	-	T
	251	Thermostat 1	Status indication setpoints heating	8 byte	C	R	-	T
	252	Thermostat 1	Status indication comfort setpoint cooling	2 byte	C	R	-	T
	253	Thermostat 1	Status indication standby setpoint cooling	2 byte	C	R	-	T
	254	Thermostat 1	Status indication night setpoint cooling	2 byte	C	R	-	T
	255	Thermostat 1	Status indication heat protection setpoint cooling	2 byte	C	R	-	T
	256	Thermostat 1	Status indication setpoints cooling	8 byte	C	R	-	T
	257	Thermostat 1	Status current setpoint	2 byte	C	R	-	T
	258	Thermostat 1	Presence	1 bit	C	R	W	-
	259	Thermostat 1	Lock-up additional step	1 bit	C	R	W	-
	260	Thermostat 1	Heating deactivation	1 bit	C	R	W	-
	261	Thermostat 1	Cooling deactivation	1 bit	C	R	W	-
	262	Thermostat 1	Heating deactivation status	1 bit	C	R	-	T
	263	Thermostat 1	Cooling deactivation status	1 bit	C	R	-	T
	264	Thermostat 1	Thermostat deactivation	1 bit	C	R	W	-
	265	Thermostat 1	Status indication thermostat deactivation	1 bit	C	R	-	T
	266	Thermostat 1	Timer	1 bit	C	R	W	-
	267	Thermostat 1	Timer duration	3 byte	C	R	W	-
	268	Thermostat 1	Setpoint selection during timer	1 byte	C	R	W	-
	269	Thermostat 1	Preset 1	1 bit	C	R	W	-
	270	Thermostat 1	Preset 2	1 bit	C	R	W	-
	271	Thermostat 1	Preset 1 authorization	1 bit	C	R	W	-
	272	Thermostat 1	Preset 2 authorization	1 bit	C	R	W	-
	273	Thermostat 1	Lock-up 1	1 bit	C	R	W	-
	274	Thermostat 1	Lock-up 2	1 bit	C	R	W	-

	Number	Name	Function of the object	Length	C	R	W	T
	275	Thermostat 1	Status indication lock-up	1 bit	C	R	-	T
	276	Thermostat 1	Valve protection date	3 byte	C	R	W	-
	277	Thermostat 1	Valve protection time	3 byte	C	R	W	-
	278	Thermostat 1	Valve protection date and time	8 byte	C	R	W	-
	279	Thermostat 1	Valve protection duration	2 byte	C	R	W	-
	280	Thermostat 1	Valve protection periodicity	2 byte	C	R	W	-
	281	Thermostat 1	Valve protection start/stop	1 bit	C	R	W	-

Note: The object designation is identical for the other thermostats. Only the object number differs.

4.3.1 Operating mode

No.	Name	Function of the object	Data type	Flags
183, 282, 381, 480, 579, 678, 777, 876, 975, 1074, 1173, 1272	Thermostat x	Setpoint selection	1 - Byte - 20.102 DPT_HVACMode	C, R, W

These objects are always activated.

This object is used to define the temperature setpoint for heating and cooling by the KNX bus.

Object value:

Heating mode	Value
Comfort	1
Standby	2
Night setpoint	3
Frost/heat protection	4

For further information, see: [Operation](#).

No.	Name	Function of the object	Data type	Flags
184, 283, 382, 481, 580, 679, 778, 877, 976, 1075, 1174, 1273	Thermostat x	Comfort	1 - Bit - 1.001 DPT_Switch	C, R, W

These objects are always activated.

This object is used to select comfort mode for heating and cooling by the KNX bus.

Object value:

- If the object receives the value 1, comfort mode is active.
- If the object receives the value 0, no action is taken.

Note: 4 operating modes in 1 bit format are available. As each mode has the same priority level, it is the last mode received which is taken into account.

For further information, see: [Operation](#).

No.	Name	Function of the object	Data type	Flags
185, 284, 383, 482, 581, 680, 779, 878, 977, 1076, 1175, 1274	Thermostat x	Standby mode	1 - Bit - 1.001 DPT_Switch	C, R, W

These objects are always activated.

This object is used to select standby mode for heating and cooling by the KNX bus.

Object value:

- If the object receives the value 1, standby mode is active.
- If the object receives the value 0, no action is taken.

Note: 4 operating modes in 1 bit format are available. As each mode has the same priority level, it is the last mode received which is taken into account.

For further information, see: [Operation](#).

No.	Name	Function of the object	Data type	Flags
186, 285, 384, 483, 582, 681, 780, 879, 978, 1077, 1176, 1275	Thermostat x	Night setpoint	1 - Bit - 1.001 DPT_Switch	C, R, W

These objects are always activated.

This object is used to select standby mode for heating and cooling by the KNX bus.

Object value:

- If the object receives the value 1, night setpoint mode is active.
- If the object receives the value 0, no action is taken.

Note: 4 operating modes in 1 bit format are available. As each mode has the same priority level, it is the last mode received which is taken into account.

For further information, see: [Operation](#).

No.	Name	Function of the object	Data type	Flags
187, 286, 385, 484, 583, 682, 781, 880, 979, 1078, 1177, 1276	Thermostat x	Frost/heat protection	1 - Bit - 1.001 DPT_Switch	C, R, W

These objects are always activated.

This object is used to select frost/heat protection mode for heating and cooling by the KNX bus.

Object value:

- If the object receives the value 1, frost/heat protection mode is active.
- If the object receives the value 0, no action is taken.

Note: 4 operating modes in 1 bit format are available. As each mode has the same priority level, it is the last mode received which is taken into account.

For further information, see: [Operation](#).

No.	Name	Function of the object	Data type	Flags										
188, 287, 386, 485, 584, 683, 782, 881, 980, 1079, 1178, 1277	Thermostat x	Setpoint selection automatic control	1 - Byte - 20.102 DPT_HVACMode	C, R, W										
<p>This object is activated when the Automatic control parameter is active. This object is used to define the temperature setpoint for heating and cooling by the KNX bus. This object is used to have an additional control operating in parallel to the standard control.</p> <p>Object value:</p> <table border="1" data-bbox="411 577 1173 739"> <thead> <tr> <th>Heating mode</th> <th>Value</th> </tr> </thead> <tbody> <tr> <td>Comfort</td> <td>1</td> </tr> <tr> <td>Standby</td> <td>2</td> </tr> <tr> <td>Night setpoint</td> <td>3</td> </tr> <tr> <td>Frost/heat protection</td> <td>4</td> </tr> </tbody> </table> <p>For further information, see: Function selection.</p>					Heating mode	Value	Comfort	1	Standby	2	Night setpoint	3	Frost/heat protection	4
Heating mode	Value													
Comfort	1													
Standby	2													
Night setpoint	3													
Frost/heat protection	4													

No.	Name	Function of the object	Data type	Flags
189, 288, 387, 486, 585, 684, 783, 882, 981, 1080, 1179, 1278	Thermostat x	Automatic control deactivation	1 - Bit - 1.003 DPT_Enable	C, R, W
<p>This object is activated when the Automatic control deactivation parameter is active. This object is used to activate the automatic control function.</p> <p>Object value:</p> <ul style="list-style-type: none"> - If the object receives the value 0, the automatic control function is active. - If the object receives the value 1, the automatic control function is inactive. <p>For further information, see: Function selection.</p>				

No.	Name	Function of the object	Data type	Flags
190, 289, 388, 487, 586, 685, 784, 883, 982, 1081, 1180, 1279	Thermostat x	Heating/Cooling - changeover	1 - Bit - 1.100 DPT_Heat_Cool	C, R, W
<p>This object is activated if the Heating/Cooling - changeover parameter has the value Through object. This object is used to define the device's thermostat operating mode by the KNX bus.</p> <p>Object value:</p> <ul style="list-style-type: none"> - If the object receives the value 0, cooling mode is active. - If the object receives the value 1, heating mode is active. <p>For further information, see: Operation.</p>				

4.3.2 Priority

No.	Name	Function of the object	Data type	Flags
191, 290, 389, 488, 587, 686, 785, 884, 983, 1082, 1181, 1280	Thermostat x	Priority	2 - Bit - 2.002 DPT_Bool_Control	C, R, W

This object is activated if the **Priority object format** parameters have the value **2 bit**.
The heating setpoint is directly determined by this object.

Details on the format of the object are given below.

Telegram received by the priority operation object			Output behaviour
Hexadecimal Value	Binary Value		
	Bit1 (MSB)	Bit0 (LSB)	
00	0	0	End of the priority
01	0	1	End of the priority
02	1	0	Priority Frost protection
03	1	1	Priority Comfort

Bit 1 of the telegram activates priority with the value 1. The heating setpoint is then locked in the status predefined by the 0 bit (0 = Frost protection, 1 = Comfort). The value 0 in bit 1 deactivates priority again.

For further information, see: [Priority](#).

No.	Name	Function of the object	Data type	Flags
192, 291, 390, 489, 588, 687, 786, 885, 984, 1083, 1182, 1281	Thermostat x	Priority (1 Bit)	1 - Bit - 1.011 DPT_State	C, R, W

This object is activated if the **Priority object format** parameters have the value **1 bit**.
This object is used to activate or deactivate priority mode for the device on the KNX bus.

Object value: Depends on the **Polarity** parameter.

1 = Priority active, 0 = Priority not active

- If the object receives the value 1, priority is active. The heating setpoint corresponds to the **Setpoint selection during priority** parameter.
- If the object receives the value 0, priority is inactive. The heating setpoint returns to the value present before the priority.

1 = Priority not active, 0 = Priority active

- If the object receives the value 0, priority is active. The heating setpoint corresponds to the **Setpoint selection during priority** parameter.
- If the object receives the value 1, priority is inactive. The heating setpoint returns to the value present before the priority.

For further information, see: [Priority](#).

No.	Name	Function of the object	Data type	Flags												
193, 292, 391, 490, 589, 688, 787, 886, 985, 1084, 1183, 1282	Thermostat x	Priority	1 - Byte - 20.102 DPT_HVACMode	C, R, W												
<p>This object is activated if the Priority object format parameters have the value Setpoint selection. This object is used to directly force the heating setpoint of the device's thermostat from the KNX bus.</p> <p>Object value:</p> <table border="1" data-bbox="411 546 1173 741"> <thead> <tr> <th>Heating mode</th> <th>Value</th> </tr> </thead> <tbody> <tr> <td>Auto</td> <td>0</td> </tr> <tr> <td>Comfort</td> <td>1</td> </tr> <tr> <td>Standby</td> <td>2</td> </tr> <tr> <td>Night setpoint</td> <td>3</td> </tr> <tr> <td>Frost/heat protection</td> <td>4</td> </tr> </tbody> </table> <p>For further information, see: Priority.</p>					Heating mode	Value	Auto	0	Comfort	1	Standby	2	Night setpoint	3	Frost/heat protection	4
Heating mode	Value															
Auto	0															
Comfort	1															
Standby	2															
Night setpoint	3															
Frost/heat protection	4															

No.	Name	Function of the object	Data type	Flags
194, 293, 392, 491, 590, 689, 788, 887, 986, 1085, 1184, 1283	Thermostat x	Windows contact	1 - Bit - 1.019 DPT_Window_Door	C, R, W
<p>These objects are always activated. This object is used to stop the heating or cooling system when a window is opened from the KNX bus.</p> <p>Object value:</p> <ul style="list-style-type: none"> - If the object receives the value 1, the window is open. The setpoint switches to frost/heat protection mode. - If the object receives the value 0, the window is closed. The setpoint returns to the mode present before the window was opened. 				

4.3.3 Scene

No.	Name	Function of the object	Data type	Flags
195, 294, 393, 492, 591, 690, 789, 888, 987, 1086, 1185, 1284	Thermostat x	Scene	1 - Byte - 18.001 DPT_SceneControl	C, R, W

This object is activated when the **Scene** parameter is active.
This object is used to recall or save a scene.

Details on the format of the object are given below:

7	6	5	4	3	2	1	0
Learning	Not used	Scene number					

Bit 7: 0: The scene is called / 1: The scene is saved.
Bit 6: Not used.
Bit 5 to Bit 0: Scene numbers from 0 (Scene 1) to 63 (Scene 64).

For further information, see: [Scene](#).

4.3.4 Status indication

No.	Name	Function of the object	Data type	Flags
196, 295, 394, 493, 592, 691, 790, 889, 988, 1087, 1186, 1285	Thermostat x	Status indication setpoint selection	1 - Byte - 20.102 DPT_HVACMode	C, R, T

These objects are always activated.

This object is used to send the setpoint status for heating and cooling by the KNX bus.

Object value:

Heating mode	Value
Comfort	1
Standby	2
Night setpoint	3
Frost/heat protection	4

For further information, see: [Operation](#).

No.	Name	Function of the object	Data type	Flags
197, 296, 395, 494, 593, 692, 791, 890, 989, 1088, 1187, 1286	Thermostat x	Automatic control deactivation status	1 - Bit - 1.003 DPT_Enable	C, R, T

This object is activated when the **Automatic control deactivation** parameter is active.
This object is used to send the status of the Automatic control deactivation function of the device on the KNX bus.

Object value:

- If the Automatic control deactivation function is deactivated, a telegram with a logical value 0 is sent.
- If the Automatic control deactivation function is activated, a telegram with a logical value 1 is sent.

This object is sent when there is a status change.

For further information, see: [Function selection](#).

No.	Name	Function of the object	Data type	Flags
198, 297, 396, 495, 594, 693, 792, 891, 990, 1089, 1188, 1287	Thermostat x	Heating/Cooling - status indication	1 - Bit - 1.100 DPT_Heat_Cool	C, R, T

These objects are always activated.
This object is used to send the operating mode status for the device's thermostat on the KNX bus.

Object value:

- If the thermostat is in heating mode, a telegram with a logic value 1 is sent.
- If the thermostat is in cooling mode, a telegram with a logic value 0 is sent.

This object is sent when there is a status change.

For further information, see: [Function selection](#).

No.	Name	Function of the object	Data type	Flags
199, 298, 397, 496, 595, 694, 793, 892, 991, 1090, 1189, 1288	Thermostat x	Status indication heating active	1 - Bit - 1.011 DPT_State	C, R, T

These objects are always activated.
This object is used to send the operating mode status for the device's thermostat on the KNX bus.

Object value:

- If heating mode is inactive, a telegram with a logic value 0 is sent.
- If heating mode is active a telegram with a logic value 1 is sent.

This object is sent when there is a status change.

For further information, see: [Function selection](#).

No.	Name	Function of the object	Data type	Flags
200, 299, 398, 497, 596, 695, 794, 893, 992, 1091, 1190, 1289	Thermostat x	Status indication cooling active	1 - Bit - 1.011 DPT_State	C, R, T

These objects are always activated.
This object is used to send the operating mode status for the device's thermostat on the KNX bus.

Object value:

- If cooling mode is inactive, a telegram with a logic value 0 is sent.
- If cooling mode is active, a telegram with a logic value 1 is sent.

This object is sent when there is a status change.

For further information, see: [Function selection](#).

No.	Name	Function of the object	Data type	Flags
201, 300, 399, 498, 597, 696, 795, 894, 993, 1092, 1191, 1290	Thermostat x	Status indication priority	1 - Bit - 1.011 DPT_State	C, R, T

This object is activated if the **Activation of priority status object** parameter is active.
This object allows the status of the Priority to be sent from the device on the KNX bus.

Object value: Depends on the **Polarity** parameter.

0 = Not forced, 1 = Forced

- If Priority is deactivated, a telegram is sent with logic value 0.
- If Priority is activated, a telegram is sent with logic value 1.

0 = Forced, 1 = Not forced

- If Priority is activated, a telegram is sent with logic value 0.
- If Priority is deactivated, a telegram is sent with logic value 1.

This object is sent periodically and/or on status change.

For further information, see: [Priority](#).

4.3.5 Controls

No.	Name	Function of the object	Data type	Flags
202, 301, 400, 499, 598, 697, 796, 895, 994, 1093, 1192, 1291	Thermostat x	ON/OFF	1 - Bit - 1.001 DPT_Switch	C, R, T
<p>This object is activated if the Function selection parameter has the value Heating and if the Type of heating control parameter has the value Switching PI-control (PWM) or Switching 2-point control.</p> <p>This object is used for valve control in heating mode according to the value sent on the KNX bus in 1 bit format.</p> <p>Object value:</p> <ul style="list-style-type: none"> - When an ON control is sent, a telegram with the logic value 1 is sent on the KNX bus. This means that an energy demand is necessary for the heating. - When an OFF control is sent, a telegram with the logic value 0 is sent on the KNX bus. This means that the energy demand for heating is no longer necessary. <p>For further information, see: Basic heating.</p>				

No.	Name	Function of the object	Data type	Flags
203, 302, 401, 500, 599, 698, 797, 896, 995, 1094, 1193, 1292	Thermostat x	Valve position in %	8 - Bit - 5.001 DPT_Scaling	C, R, T
<p>This object is activated if the Function selection parameter has the value Heating and if the Type of heating control parameter has the value Continuous PI-control.</p> <p>This object is used for valve control in heating mode according to the value sent on the KNX bus in 1 byte format.</p> <p>Object value: 0 to 255: 0 = 0%, 255 = 100%</p> <p>For further information, see: Basic heating.</p>				

No.	Name	Function of the object	Data type	Flags
204, 303, 402, 501, 600, 699, 798, 897, 996, 1095, 1194, 1293	Thermostat x	ON/OFF - basic cooling	1 - Bit - 1.001 DPT_Switch	C, R, T
<p>This object is activated if the Function selection parameter has the value Cooling and the Type of heating control parameter has the value Switching PI-control (PWM) or Switching 2-point control.</p> <p>This object is used for valve control in cooling mode according to the value sent on the KNX bus in 1 bit format.</p> <p>Object value:</p> <ul style="list-style-type: none"> - When an ON control is sent, a telegram with the logic value 1 is sent on the KNX bus. This means that an energy demand is necessary for cooling. - When an OFF control is sent, a telegram with the logic value 0 is sent on the KNX bus. This means that the energy demand for cooling is no longer necessary. <p>For further information, see: Basic cooling.</p>				

No.	Name	Function of the object	Data type	Flags
205, 304, 403, 502, 601, 700, 799, 898, 997, 1096, 1195, 1294	Thermostat x	Valve position in % - basic cooling	8 - Bit - 5.001 DPT_Scaling	C, R, T
<p>This object is activated if the Function selection parameter has the value Cooling and the Type of heating control parameter has the value Continuous PI-control.</p> <p>This object is used for valve control in cooling mode according to the value sent on the KNX bus in 1 byte format.</p> <p>Object value: 0 to 255: 0 = 0%, 255 = 100%</p> <p>For further information, see: Basic cooling.</p>				

No.	Name	Function of the object	Data type	Flags
206, 305, 404, 503, 602, 701, 800, 899, 998, 1097, 1196, 1295	Thermostat x	ON/OFF - additional heating	1 - Bit - 1.001 DPT_Switch	C, R, T
<p>This object is activated if the Function selection parameter has the value Basic and additional heating or Basic and additional cooling and if the Type of heating control has the value Switching PI-control (PWM) or Switching 2-point control.</p> <p>This object is used to control a second valve in heating mode according to the value sent on the KNX bus in 1 bit format.</p> <p>Object value:</p> <ul style="list-style-type: none"> - When an ON control is sent, a telegram with the logic value 1 is sent on the KNX bus. This means that an energy demand is necessary for the heating. - When an OFF control is sent, a telegram with the logic value 0 is sent on the KNX bus. This means that the energy demand for heating is no longer necessary. <p>For further information, see: Additional heating.</p>				

No.	Name	Function of the object	Data type	Flags
207, 306, 405, 504, 603, 702, 801, 900, 999, 1098, 1197, 1296	Thermostat x	Valve position in % - additional heating	8 - Bit - 5.001 DPT_Scaling	C, R, T
<p>This object is activated if the Function selection parameter has the value Basic and additional heating or Basic and additional cooling and if the Type of heating control parameter has the value Continuous PI-control.</p> <p>This object is used to control a second valve in heating mode according to the value sent on the KNX bus in 1 byte format.</p> <p>Object value: 0 to 255: 0 = 0%, 255 = 100%</p> <p>For further information, see: Additional heating.</p>				

No.	Name	Function of the object	Data type	Flags
208, 307, 406, 505, 604, 703, 802, 901, 1000, 1099, 1198, 1297	Thermostat x	ON/OFF - additional cooling	1 - Bit - 1.001 DPT_Switch	C, R, T
<p>This object is activated when the Function selection parameter has the value Basic and additional cooling or Basic and additional heating and cooling and the Type of heating control parameter has the value Switching PI-control (PWM) or Switching 2-point control.</p> <p>This object is used to control a second valve in cooling mode according to the value sent on the KNX bus in 1 bit format.</p> <p>Object value:</p> <ul style="list-style-type: none"> - When an ON control is sent, a telegram with the logic value 1 is sent on the KNX bus. This means that an energy demand is necessary for cooling. - When an OFF control is sent, a telegram with the logic value 0 is sent on the KNX bus. This means that the energy demand for cooling is no longer necessary. <p>For further information, see: Additional cooling.</p>				

No.	Name	Function of the object	Data type	Flags
209, 308, 407, 506, 605, 704, 803, 902, 1001, 1100, 1199, 1298	Thermostat x	Valve position in % - additional cooling	8 - Bit - 5.001 DPT_Scaling	C, R, T
<p>This object is activated when the Function selection parameter has the value Basic and additional cooling or Basic and additional heating and cooling and the Type of heating control parameter has the value Continuous PI-control.</p> <p>This object is used to control a second valve in cooling mode according to the value sent on the KNX bus in 1 byte format.</p> <p>Object value: 0 to 255: 0 = 0%, 255 = 100%</p> <p>For further information, see: Additional cooling .</p>				

4.3.6 Room temperature

No.	Name	Function of the object	Data type	Flags
210, 309, 408, 507, 606, 705, 804, 903, 1002, 1101, 1200, 1299	Thermostat x	Room temperature 1	2 - Byte - 9.001 DPT_Value_Temp	C, R, W
<p>These objects are always activated.</p> <p>This object is used to read a room temperature using an external sensor.</p> <p>Object value: -273 ... +670760 in °C</p> <p>For further information, see: Temperature measurement.</p>				

No.	Name	Function of the object	Data type	Flags
211, 310, 409, 508, 607, 706, 805, 904, 1003, 1102, 1201, 1300	Thermostat x	Room temperature 2	2 - Byte - 9.001 DPT_Value_Temp	C, R, W
<p>This object is activated if the Room temperature detection parameter has the value Through 2 objects or Through 3 objects.</p> <p>This object is used to read a room temperature using a second external sensor. This allows several sensors to be mounted in cascade for better temperature measurement accuracy.</p> <p>Object value: -273 ... +670760 in °C</p> <p>For further information, see: Temperature measurement.</p>				

No.	Name	Function of the object	Data type	Flags
212, 311, 410, 509, 608, 707, 806, 905, 1004, 1103, 1202, 1301	Thermostat x	Room temperature 3	2 - Byte - 9.001 DPT_Value_Temp	C, R, W
<p>This object is activated if the Room temperature detection parameter has the value Through 3 objects. This object is used to read a room temperature using a third external sensor. This allows several sensors to be mounted in cascade for better temperature measurement accuracy.</p> <p>Object value: -273 ... +670760 in °C</p> <p>For further information, see: Temperature measurement.</p>				

No.	Name	Function of the object	Data type	Flags
213, 312, 411, 510, 609, 708, 807, 906, 1005, 1104, 1203, 1302	Thermostat x	Floor temperature	2 - Byte - 9.001 DPT_Value_Temp	C, R, W
<p>This object is activated if the Type of heating equipment parameter has the value Warm water underfloor heating or Electrical underfloor heating and if the Floor temperature detection parameter is active. This object is used to read the floor temperature using an external sensor. This makes it possible to limit the floor temperature.</p> <p>Object value: -273 ... +670760 in °C</p> <p>For further information, see: Temperature measurement.</p>				

No.	Name	Function of the object	Data type	Flags
214, 313, 412, 511, 610, 709, 808, 907, 1006, 1105, 1204, 1303	Thermostat x	Status indication room temperature	2 - Byte - 9.001 DPT_Value_Temp	C, R, W
<p>These objects are always activated. This object is used to indicate the real temperature value taken into account by the regulator.</p> <p>Object value: -273 ... +670760 in °C This object is sent periodically and/or on status change.</p> <p>For further information, see: Temperature measurement.</p>				

No.	Name	Function of the object	Data type	Flags
215, 314, 413, 512, 611, 710, 809, 908, 1007, 1106, 1205, 1304	Thermostat x	Room temperature failure	1 - Bit - 1.005 DPT_Alarm	C, R, T
<p>This object is activated when the Emission room temperature alarm through objects parameter is active. This object is used to send a room temperature failure alarm from the product on the KNX bus.</p> <ul style="list-style-type: none"> - The alarm is active (bit = 1) if no temperature is measured after the time defined by the Timeout of room temperature parameter. - The alarm is inactive (bit = 0) if the temperature measurement is carried out during the time defined by the Timeout of room temperature parameter. <p><i>Note: If the Object room temperature failure polarity parameter has the value Inverted, the polarity of the object is inverted.</i></p> <p>For further information, see: Temperature measurement.</p>				

No.	Name	Function of the object	Data type	Flags
216, 315, 414, 513, 612, 711, 810, 909, 1008, 1107, 1206, 1305	Thermostat x	Minimum room temperature	1 - Bit - 1.005 DPT_Alarm	C, R, T
<p>This object is activated when the Emission room temperature alarm through objects parameter is active. This object is used to send an alarm indicating a room temperature less than the minimum threshold from the product on the KNX bus.</p> <ul style="list-style-type: none"> - The alarm is active (bit = 1) if the measured temperature is less than the minimum threshold defined by the Minimum room temperature parameter. - The alarm is inactive (bit = 0) if the measured temperature is higher than the minimum threshold defined by the Minimum room temperature parameter. <p><i>Note: If the Object room temperature lower limit alarm polarity parameter has the value Inverted, the polarity of the object is inverted.</i></p> <p>For further information, see: Temperature measurement.</p>				

No.	Name	Function of the object	Data type	Flags
217, 316, 415, 514, 613, 712, 811, 910, 1009, 1108, 1207, 1306	Thermostat x	Maximum room temperature	1 - Bit - 1.005 DPT_Alarm	C, R, T
<p>This object is activated when the Emission room temperature alarm through objects parameter is active. This object is used to send an alarm indicating a room temperature higher than the maximum threshold from the product on the KNX bus.</p> <ul style="list-style-type: none"> - The alarm is active (bit = 1) if the measured temperature is higher than the maximum threshold defined by the Maximum room temperature parameter. - The alarm is inactive (bit = 0) if the measured temperature is lower than the maximum threshold defined by the Maximum room temperature parameter. <p><i>Note: If the Object room temperature upper limit alarm polarity parameter has the value Inverted, the polarity of the object is inverted.</i></p> <p>For further information, see: Temperature measurement.</p>				

4.3.7 Ventilation

No.	Name	Function of the object	Data type	Flags
218, 317, 416, 515, 614, 713, 812, 911, 1010, 1109, 1208, 1307	Thermostat x	Ventilation automatic/manual mode	1 - Bit - 1.001 DPT_Switch	C, R, W

This object is activated when the **Ventilation available** parameter is active.
This object is used to switch the ventilation from automatic mode to manual mode and vice versa by the KNX bus.

Object value: Depends on the **Polarity** parameter.

0 = automatic mode, 1 = manual mode

- If the object receives the value 0, the ventilation switches to automatic mode.
- If the object receives the value 1, the ventilation switches to manual mode.

1 = automatic mode, 0 = manual mode

- If the object receives the value 0, the ventilation switches to manual mode.
- If the object receives the value 1, the ventilation switches to automatic mode.

For further information, see: [Ventilation](#).

No.	Name	Function of the object	Data type	Flags
219, 318, 417, 516, 615, 714, 813, 912, 1011, 1110, 1209, 1308	Thermostat x	Status ventilation step 1-6	8 - Bit - 5.010 DPT_Value_1_Ucount	C, R, W

This object is activated when the **Ventilation available** parameter is active.
This object is used to know the status of the ventilation step by the KNX bus.

Object value	Ventilation step
0	No ventilation
1	Ventilation step 1
2	Ventilation step 2
3	Ventilation step 3
4	Ventilation step 4
5	Ventilation step 5
6	Ventilation step 6

For further information, see: [Ventilation](#).

No.	Name	Function of the object	Data type	Flags
220, 319, 418, 517, 616, 715, 814, 913, 1012, 1111, 1210, 1309	Thermostat x	Status ventilation step 1	1 - Bit - 1.001 DPT_Switch	C, R, W
<p>This object is activated when the Ventilation available parameter is active and when the Ventilation object parameter has the value (1 bit) object. This object is used to know the status of ventilation step 1 by the KNX bus.</p> <p>Object value:</p> <ul style="list-style-type: none"> - If the object receives the value 0, ventilation step 1 is deactivated. - If the object receives the value 1, ventilation step 1 is activated. <p>For further information, see: Ventilation.</p>				

No.	Name	Function of the object	Data type	Flags
221, 320, 419, 518, 617, 716, 815, 914, 1013, 1112, 1211, 1310	Thermostat x	Status ventilation step 2	1 - Bit - 1.001 DPT_Switch	C, R, W
<p>This object is activated when the Ventilation available parameter is active and when the Ventilation object parameter has the value (1 bit) object. See object No. 220.</p>				

No.	Name	Function of the object	Data type	Flags
222, 321, 420, 519, 618, 717, 816, 915, 1014, 1113, 1212, 1311	Thermostat x	Status ventilation step 3	1 - Bit - 1.001 DPT_Switch	C, R, W
<p>This object is activated when the Ventilation available parameter is active and when the Ventilation object parameter has the value (1 bit) object. See object No. 220.</p>				

No.	Name	Function of the object	Data type	Flags
223, 322, 421, 520, 619, 718, 817, 916, 1015, 1114, 1213, 1312	Thermostat x	Status ventilation step 4	1 - Bit - 1.001 DPT_Switch	C, R, W
<p>This object is activated when the Ventilation available parameter is active and when the Ventilation object parameter has the value (1 bit) object. See object No. 220.</p>				

No.	Name	Function of the object	Data type	Flags
224, 323, 422, 521, 620, 719, 818, 917, 1016, 1115, 1214, 1313	Thermostat x	Status ventilation step 5	1 - Bit - 1.001 DPT_Switch	C, R, W
<p>This object is activated when the Ventilation available parameter is active and when the Ventilation object parameter has the value (1 bit) object. See object No. 220.</p>				

No.	Name	Function of the object	Data type	Flags
225, 324, 423, 522, 621, 720, 819, 918, 1017, 1116, 1215, 1314	Thermostat x	Status ventilation step 6	1 - Bit - 1.001 DPT_Switch	C, R, W
<p>This object is activated when the Ventilation available parameter is active and when the Ventilation object parameter has the value (1 bit) object. See object No. 220.</p>				

No.	Name	Function of the object	Data type	Flags																
226, 325, 424, 523, 622, 721, 820, 919, 1018, 1117, 1216, 1315	Thermostat x	Ventilation step 1-6	8 - Bit - 5.010 DPT_Value_1_Ucount	C, R, T																
<p>This object is activated when the Ventilation available parameter is active. This object is used to send the ventilation step from the product on the KNX bus. This value is define by the regulator according to the ventilation settings thresholds.</p> <table border="1" data-bbox="411 1240 1171 1498"> <thead> <tr> <th>Object value</th> <th>Ventilation step</th> </tr> </thead> <tbody> <tr> <td>0</td> <td>No ventilation</td> </tr> <tr> <td>1</td> <td>Ventilation step 1</td> </tr> <tr> <td>2</td> <td>Ventilation step 2</td> </tr> <tr> <td>3</td> <td>Ventilation step 3</td> </tr> <tr> <td>4</td> <td>Ventilation step 4</td> </tr> <tr> <td>5</td> <td>Ventilation step 5</td> </tr> <tr> <td>6</td> <td>Ventilation step 6</td> </tr> </tbody> </table> <p>For further information, see: Ventilation.</p>					Object value	Ventilation step	0	No ventilation	1	Ventilation step 1	2	Ventilation step 2	3	Ventilation step 3	4	Ventilation step 4	5	Ventilation step 5	6	Ventilation step 6
Object value	Ventilation step																			
0	No ventilation																			
1	Ventilation step 1																			
2	Ventilation step 2																			
3	Ventilation step 3																			
4	Ventilation step 4																			
5	Ventilation step 5																			
6	Ventilation step 6																			

No.	Name	Function of the object	Data type	Flags
227, 326, 425, 524, 623, 722, 821, 920, 1019, 1118, 1217, 1316	Thermostat x	Ventilation step 1	1 - Bit - 1.001 DPT_Switch	C, R, T
<p>This object is activated when the Ventilation available parameter is active and when the Ventilation object parameter has the value (1 bit) object.</p> <p>This object is used to send ventilation step 1 from the product on the KNX bus. This value is define by the regulator according to the ventilation settings thresholds.</p> <p>Object value:</p> <ul style="list-style-type: none"> - If ventilation step 1 is deactivated, a telegram with the logic value 0 is sent on the KNX bus. - If ventilation step 1 is activated, a telegram with the logic value 1 is sent on the KNX bus. <p>For further information, see: Ventilation.</p>				

No.	Name	Function of the object	Data type	Flags
228, 327, 426, 525, 624, 723, 822, 921, 1020, 1119, 1218, 1317	Thermostat x	Ventilation step 2	1 - Bit - 1.001 DPT_Switch	C, R, T
<p>This object is activated when the Ventilation available parameter is active and when the Ventilation object parameter has the value (1 bit) object.</p> <p>See object No. 227.</p>				

No.	Name	Function of the object	Data type	Flags
229, 328, 427, 526, 625, 724, 823, 922, 1021, 1120, 1219, 1318	Thermostat x	Ventilation step 3	1 - Bit - 1.001 DPT_Switch	C, R, T
<p>This object is activated when the Ventilation available parameter is active and when the Ventilation object parameter has the value (1 bit) object.</p> <p>See object No. 227.</p>				

No.	Name	Function of the object	Data type	Flags
230, 329, 428, 527, 626, 725, 824, 923, 1022, 1121, 1220, 1319	Thermostat x	Ventilation step 4	1 - Bit - 1.001 DPT_Switch	C, R, T
<p>This object is activated when the Ventilation available parameter is active and when the Ventilation object parameter has the value (1 bit) object.</p> <p>See object No. 227.</p>				

No.	Name	Function of the object	Data type	Flags
231, 330, 429, 528, 627, 726, 825, 924, 1023, 1122, 1221, 1320	Thermostat x	Ventilation step 5	1 - Bit - 1.001 DPT_Switch	C, R, T
<p>This object is activated when the Ventilation available parameter is active and when the Ventilation object parameter has the value (1 bit) object. See object No. 227.</p>				

No.	Name	Function of the object	Data type	Flags
232, 331, 430, 529, 628, 727, 826, 925, 1024, 1123, 1222, 1321	Thermostat x	Ventilation step 6	1 - Bit - 1.001 DPT_Switch	C, R, T
<p>This object is activated when the Ventilation available parameter is active and when the Ventilation object parameter has the value (1 bit) object. See object No. 227.</p>				

4.3.8 Setpoints

No.	Name	Function of the object	Data type	Flags
233, 332, 431, 530, 629, 728, 827, 926, 1025, 1124, 1223, 1322	Thermostat x	Comfort setpoint heating	2 - Byte - 9.001 DPT_Value_Temp	C, R, W
<p>This object is activated if the Setpoint objects parameter has the value Simple or Both. This object is used to define the temperature setpoint value of comfort mode for heating by the KNX bus.</p> <p>Object value: -273 to +670760 in °C The temperature range taken into account: 5 to 40 in °C</p> <p>For further information, see: Setpoints.</p>				

No.	Name	Function of the object	Data type	Flags
234, 333, 432, 531, 630, 729, 828, 927, 1026, 1125, 1224, 1323	Thermostat x	Standby setpoint heating	2 - Byte - 9.001 DPT_Value_Temp	C, R, W
<p>This object is activated if the Setpoint objects parameter has the value Simple or Both. This object is used to define the temperature setpoint value of standby mode for heating by the KNX bus.</p> <p>Object value: -273 to +670760 in °C The temperature range taken into account: 5 to 40 in °C</p> <p>For further information, see: Setpoints.</p>				

No.	Name	Function of the object	Data type	Flags
235, 334, 433, 532, 631, 730, 829, 928, 1027, 1126, 1225, 1324	Thermostat x	Night setpoint heating	2 - Byte - 9.001 DPT_Value_Temp	C, R, W
<p>This object is activated if the Setpoint objects parameter has the value Simple or Both. This object is used to define the temperature setpoint value of night setpoint mode for heating by the KNX bus.</p> <p>Object value: -273 to +670760 in °C The temperature range taken into account: 5 to 40 in °C</p> <p>For further information, see: Setpoints.</p>				

No.	Name	Function of the object	Data type	Flags
236, 335, 434, 533, 632, 731, 830, 929, 1028, 1127, 1226, 1325	Thermostat x	Frost protection setpoint heating	2 - Byte - 9.001 DPT_Value_Temp	C, R, W
<p>This object is activated if the Setpoint objects parameter has the value Simple or Both. This object is used to define the temperature setpoint value of frost protection for heating by the KNX bus.</p> <p>Object value: -273 to +670760 in °C The temperature range taken into account: 5 to 40 in °C</p> <p>For further information, see: Setpoints.</p>				

No.	Name	Function of the object	Data type	Flags
237, 336, 435, 534, 633, 732, 831, 930, 1029, 1128, 1227, 1326	Thermostat x	Setpoints heating	8 - Byte - 275.100 DPT_TempRoomSetpSetF16 [4]	C, R, W

This object is activated if the **Setpoint objects** parameter has the value **Combined** or **Both**.
 This object is used to define the temperature setpoint value of comfort, standby, night setpoint and frost protection mode for heating by the KNX bus.

Object value:

Comfort setpoint								Standby setpoint																							
Byte 8 (MSB)				Byte 7 (LSB)				Byte 6 (MSB)				Byte 5 (LSB)																			
F	F	F	F	F	F	F	F	F	F	F	F	F	F	F	F	F	F	F	F	F	F	F	F	F	F	F	F	F	F	F	F

Night setpoint								Frost protection setpoint																							
Byte 4 (MSB)				Byte 3 (LSB)				Byte 2 (MSB)				Byte 1 (LSB)																			
F	F	F	F	F	F	F	F	F	F	F	F	F	F	F	F	F	F	F	F	F	F	F	F	F	F	F	F	F	F	F	F

Fields	Description	Value	Units
Comfort setpoint	Comfort mode temperature setpoint	- 273 to 655.34 Resolution 0,01	°C
Standby setpoint	Standby mode temperature setpoint	- 273 to 655.34 Resolution 0,01	°C
Night setpoint	Night setpoint mode temperature setpoint	- 273 to 655.34 Resolution 0,01	°C
Frost protection setpoint	Frost protection mode temperature setpoint	- 273 to 655.34 Resolution 0,01	°C

For further information, see: [Setpoints](#).

No.	Name	Function of the object	Data type	Flags
238, 337, 436, 535, 634, 733, 832, 931, 1030, 1129, 1228, 1327	Thermostat x	Comfort setpoint cooling	2 - Byte - 9.001 DPT_Value_Temp	C, R, W

This object is activated if the **Setpoint objects** parameter has the value **Simple** or **Both**.
 This object is used to define the temperature setpoint value of comfort mode for cooling by the KNX bus.

Object value: -273 to +670760 in °C
 The temperature range taken into account: 5 to 40 in °C

For further information, see: [Setpoints](#).

No.	Name	Function of the object	Data type	Flags
239, 338, 437, 536, 635, 734, 833, 932, 1031, 1130, 1229, 1328	Thermostat x	Standby setpoint cooling	2 - Byte - 9.001 DPT_Value_Temp	C, R, W
<p>This object is activated if the Setpoint objects parameter has the value Simple or Both. This object is used to define the temperature setpoint value of standby mode for cooling by the KNX bus.</p> <p>Object value: -273 to +670760 in °C The temperature range taken into account: 5 to 40 in °C</p> <p>For further information, see: Setpoints.</p>				

No.	Name	Function of the object	Data type	Flags
240, 339, 438, 537, 636, 735, 834, 933, 1032, 1131, 1230, 1329	Thermostat x	Night setpoint cooling	2 - Byte - 9.001 DPT_Value_Temp	C, R, W
<p>This object is activated if the Setpoint objects parameter has the value Simple or Both. This object is used to define the temperature setpoint value of night setpoint mode for cooling by the KNX bus.</p> <p>Object value: -273 to +670760 in °C The temperature range taken into account: 5 to 40 in °C</p> <p>For further information, see: Setpoints.</p>				

No.	Name	Function of the object	Data type	Flags
241, 340, 439, 538, 637, 736, 835, 934, 1033, 1132, 1231, 1330	Thermostat x	Heat protection setpoint cooling	2 - Byte - 9.001 DPT_Value_Temp	C, R, W
<p>This object is activated if the Setpoint objects parameter has the value Simple or Both. This object is used to define the temperature setpoint value of heat protection mode for cooling by the KNX bus.</p> <p>Object value: -273 to +670760 in °C The temperature range taken into account: 5 to 40 in °C</p> <p>For further information, see: Setpoints.</p>				

No.	Name	Function of the object	Data type	Flags
242, 341, 440, 539, 638, 737, 836, 935, 1034, 1133, 1232, 1331	Thermostat x	Setpoints cooling	8 - Byte - 275.100 DPT_TempRoomSetpSetF16 [4]	C, R, W

This object is activated if the **Setpoint objects** parameter has the value **Combined** or **Both**.
This object is used to define the temperature setpoint value of comfort, standby, night setpoint and heat protection mode for cooling by the KNX bus.

Object value:

Comfort setpoint								Standby setpoint											
Byte 8 (MSB)				Byte 7 (LSB)				Byte 6 (MSB)				Byte 5 (LSB)							
F	F	F	F	F	F	F	F	F	F	F	F	F	F	F	F	F	F	F	F

Night setpoint				Heat protection setpoint											
Byte 4 (MSB)		Byte 3 (LSB)		Byte 2 (MSB)		Byte 1 (LSB)									
F	F	F	F	F	F	F	F	F	F	F	F	F	F	F	F

Fields	Description	Value	Units
Comfort setpoint	Comfort mode temperature setpoint	- 273 to 655.34 Resolution 0,01	°C
Standby setpoint	Standby mode temperature setpoint	- 273 to 655.34 Resolution 0,01	°C
Night setpoint	Night setpoint mode temperature setpoint	- 273 to 655.34 Resolution 0,01	°C
Heat protection setpoint	Heat protection mode temperature setpoint	- 273 to 655.34 Resolution 0,01	°C

For further information, see: [Setpoints](#).

No.	Name	Function of the object	Data type	Flags
243, 342, 441, 540, 639, 738, 837, 936, 1035, 1134, 1233, 1332	Thermostat x	Setpoint shift	2 - Byte - 9.002 DPT_Value_Temp	C, R, W

These objects are always activated.
This object is used to define the setpoint override value for heating and cooling by the KNX bus.

Object value: -670 760 to +670 760 in K
The temperature range taken into account: 1 to 20 in K

Note: A temperature offset is expressed in Kelvin. 1K of temperature offset corresponds to 1°C.

For further information, see: [Setpoints](#).

No.	Name	Function of the object	Data type	Flags
244, 343, 442, 541, 640, 739, 838, 937, 1036, 1135, 1234, 1333	Thermostat x	Current setpoint	2 - Byte - 9.001 DPT_Value_Temp	C, R, W
<p>These objects are always activated. This object is used to define the temperature value for heating and cooling directly by the KNX bus.</p> <p>Object value: -273 to +670760 in °C The temperature range taken into account: 5 to 40 in °C</p> <p>For further information, see: Setpoints.</p>				

4.3.9 Setpoint status indication

No.	Name	Function of the object	Data type	Flags
245, 344, 443, 542, 641, 740, 839, 938, 1037, 1136, 1235, 1334	Thermostat x	Status indication setpoint shift	2 - Byte - 9.002 DPT_Value_Tempd	C, R, T
<p>These objects are always activated. This object is used to send the setpoint override value for heating and cooling on the KNX bus.</p> <p>Object value: -670 760 to +670 760 in K The temperature range taken into account: 1 to 20 in K This object is sent periodically and/or on status change.</p> <p><i>Note: A temperature offset is expressed in Kelvin. 1K of temperature offset corresponds to 1°C.</i></p> <p>For further information, see: Setpoints.</p>				

No.	Name	Function of the object	Data type	Flags
246, 345, 444, 543, 642, 741, 840, 939, 1038, 1137, 1236, 1335	Thermostat x	Status indication reference setpoint	2 - Byte - 9.001 DPT_Value_Temp	C, R, T
<p>This object is only visible if the Setpoints preset parameter has the following value Relative (offset from basic setpoint). This object is used to send the temperature value for heating and cooling on the KNX bus.</p> <p>Object value: -273 to +670760 in °C The temperature range taken into account: 5 to 40 in °C This object is sent periodically and/or on status change.</p> <p>For further information, see: Setpoints.</p>				

No.	Name	Function of the object	Data type	Flags
247, 346, 445, 544, 643, 742, 841, 940, 1039, 1138, 1237, 1336	Thermostat x	Status indication comfort setpoint heating	2 - Byte - 9.001 DPT_Value_Temp	C, R, T
<p>This object is only visible if the Setpoint objects parameter has the following value Simple or Both. This object is used to send the temperature setpoint value of comfort mode for heating on the KNX bus.</p> <p>Object value: -273 to +670760 in °C The temperature range taken into account: 5 to 40 in °C This object is sent periodically and/or on status change.</p> <p>For further information, see: Setpoints.</p>				

No.	Name	Function of the object	Data type	Flags
248, 347, 446, 545, 644, 743, 842, 941, 1040, 1139, 1238, 1337	Thermostat x	Status indication standby setpoint heating	2 - Byte - 9.001 DPT_Value_Temp	C, R, T
<p>This object is only visible if the Setpoint objects parameter has the following value Simple or Both. This object is used to send the temperature setpoint value of standby mode for heating on the KNX bus.</p> <p>Object value: -273 to +670760 in °C The temperature range taken into account: 5 to 40 in °C This object is sent periodically and/or on status change.</p> <p>For further information, see: Setpoints.</p>				

No.	Name	Function of the object	Data type	Flags
249, 348, 447, 546, 645, 744, 843, 942, 1041, 1140, 1239, 1338	Thermostat x	Status indication night setpoint heating	2 - Byte - 9.001 DPT_Value_Temp	C, R, T
<p>This object is only visible if the Setpoint objects parameter has the following value Simple or Both. This object is used to send the temperature setpoint value of night setpoint mode for heating on the KNX bus.</p> <p>Object value: -273 to +670760 in °C The temperature range taken into account: 5 to 40 in °C This object is sent periodically and/or on status change.</p> <p>For further information, see: Setpoints.</p>				

No.	Name	Function of the object	Data type	Flags
250, 349, 448, 547, 646, 745, 844, 943, 1042, 1141, 1240, 1339	Thermostat x	Status indication frost protection setpoint heating	2 - Byte - 9.001 DPT_Value_Temp	C, R, T

This object is only visible if the **Setpoint objects** parameter has the following value **Simple** or **Both**.
This object is used to send the temperature setpoint value of frost protection mode for heating on the KNX bus.

Object value: -273 to +670760 in °C
The temperature range taken into account: 5 to 40 in °C
This object is sent periodically and/or on status change.

For further information, see: [Setpoints](#).

No.	Name	Function of the object	Data type	Flags
251, 350, 449, 548, 647, 746, 845, 944, 1043, 1142, 1241, 1340	Thermostat x	Status indication setpoints heating	8 - Byte - 275.100 DPT_TempRoomSetpSetF16 [4]	C, R, T

This object is only visible if the **Setpoint objects** parameter has the following value **Combined** or **Both**.
This object is used to send the temperature setpoint value of comfort, standby, night setpoint and frost protection mode for heating on the KNX bus.

Object value:

Comfort setpoint								Standby setpoint											
Byte 8 (MSB)				Byte 7 (LSB)				Byte 6 (MSB)				Byte 5 (LSB)							
F	F	F	F	F	F	F	F	F	F	F	F	F	F	F	F	F	F	F	F

Night setpoint								Frost protection setpoint											
Byte 4 (MSB)				Byte 3 (LSB)				Byte 2 (MSB)				Byte 1 (LSB)							
F	F	F	F	F	F	F	F	F	F	F	F	F	F	F	F	F	F	F	F

Fields	Description	Value	Units
Comfort setpoint	Comfort mode temperature setpoint	- 273 to 655.34 Resolution 0,01	°C
Standby setpoint	Standby mode temperature setpoint	- 273 to 655.34 Resolution 0,01	°C
Night setpoint	Night setpoint mode temperature setpoint	- 273 to 655.34 Resolution 0,01	°C
Frost protection setpoint	Frost protection mode temperature setpoint	- 273 to 655.34 Resolution 0,01	°C

This object is sent periodically and/or on status change.

For further information, see: [Setpoints](#).

No.	Name	Function of the object	Data type	Flags
252, 351, 450, 549, 648, 747, 846, 945, 1044, 1143, 1242, 1341	Thermostat x	Status indication comfort setpoint cooling	2 - Byte - 9.001 DPT_Value_Temp	C, R, T
<p>This object is only visible if the Setpoint objects parameter has the following value Simple or Both. This object is used to send the temperature setpoint value of comfort mode for cooling on the KNX bus.</p> <p>Object value: -273 to +670760 in °C The temperature range taken into account: 5 to 40 in °C This object is sent periodically and/or on status change.</p> <p>For further information, see: Setpoints.</p>				

No.	Name	Function of the object	Data type	Flags
253, 352, 451, 550, 649, 748, 847, 946, 1045, 1144, 1243, 1342	Thermostat x	Status indication standby setpoint cooling	2 - Byte - 9.001 DPT_Value_Temp	C, R, T
<p>This object is only visible if the Setpoint objects parameter has the following value Simple or Both. This object is used to send the temperature setpoint value of standby mode for cooling on the KNX bus.</p> <p>Object value: -273 to +670760 in °C The temperature range taken into account: 5 to 40 in °C This object is sent periodically and/or on status change.</p> <p>For further information, see: Setpoints.</p>				

No.	Name	Function of the object	Data type	Flags
254, 353, 452, 551, 650, 749, 848, 947, 1046, 1145, 1244, 1343	Thermostat x	Status indication night setpoint cooling	2 - Byte - 9.001 DPT_Value_Temp	C, R, T
<p>This object is only visible if the Setpoint objects parameter has the following value Simple or Both. This object is used to send the temperature setpoint value of night setpoint mode for cooling on the KNX bus.</p> <p>Object value: -273 to +670760 in °C The temperature range taken into account: 5 to 40 in °C This object is sent periodically and/or on status change.</p> <p>For further information, see: Setpoints.</p>				

No.	Name	Function of the object	Data type	Flags
255, 354, 453, 552, 651, 750, 849, 948, 1047, 1146, 1245, 1344	Thermostat x	Status indication heat protection setpoint cooling	2 - Byte - 9.001 DPT_Value_Temp	C, R, T

This object is only visible if the **Setpoint objects** parameter has the following value **Simple** or **Both**.
This object is used to send the temperature setpoint value of heat protection mode for cooling on the KNX bus.

Object value: -273 to +670760 in °C
The temperature range taken into account: 5 to 40 in °C
This object is sent periodically and/or on status change.

For further information, see: [Setpoints](#).

No.	Name	Function of the object	Data type	Flags
256, 355, 454, 553, 652, 751, 850, 949, 1048, 1147, 1246, 1345	Thermostat x	Status indication setpoints cooling	8 - Byte - 275.100 DPT_TempRoomSetpSetF16 [4]	C, R, T

This object is only visible if the **Setpoint objects** parameter has the following value **Combined** or **Both**.
This object is used to send the temperature setpoint value of comfort, standby, night setpoint and heat protection mode for cooling on the KNX bus.

Object value:

Comfort setpoint								Standby setpoint											
Byte 8 (MSB)				Byte 7 (LSB)				Byte 6 (MSB)				Byte 5 (LSB)							
F	F	F	F	F	F	F	F	F	F	F	F	F	F	F	F	F	F	F	F

Night setpoint								Heat protection setpoint											
Byte 4 (MSB)				Byte 3 (LSB)				Byte 2 (MSB)				Byte 1 (LSB)							
F	F	F	F	F	F	F	F	F	F	F	F	F	F	F	F	F	F	F	F

Fields	Description	Value	Units
Comfort setpoint	Comfort mode temperature setpoint	- 273 to 655.34 Resolution 0,01	°C
Standby setpoint	Standby mode temperature setpoint	- 273 to 655.34 Resolution 0,01	°C
Night setpoint	Night setpoint mode temperature setpoint	- 273 to 655.34 Resolution 0,01	°C
Heat protection setpoint	Heat protection mode temperature setpoint	- 273 to 655.34 Resolution 0,01	°C

This object is sent periodically and/or on status change.

For further information, see: [Setpoints](#).

No.	Name	Function of the object	Data type	Flags
257, 356, 455, 554, 653, 752, 851, 950, 1049, 1148, 1247, 1346	Thermostat x	Status current setpoint	2 - Byte - 9.001 DPT_Value_Temp	C, R, T
<p>These objects are always activated. This object is used to send the current temperature setpoint value on the KNX bus.</p> <p>Object value: -273 to +670760 in °C The temperature range taken into account: 5 to 40 in °C This object is sent periodically and/or on status change.</p> <p>For further information, see: Setpoints.</p>				

4.3.10 Presence

No.	Name	Function of the object	Data type	Flags
258, 357, 456, 555, 654, 753, 852, 951, 1050, 1149, 1248, 1347	Thermostat x	Presence	1 - Bit - 1.001 DPT_Switch	C, R, W
<p>This object is activated when the Presence detection parameter is active. This object is used to send a notification of user presence or absence in order to extend comfort mode for a configurable duration.</p> <p>Object value:</p> <ul style="list-style-type: none"> - If the object receives the value 0, this means the user is absent. - If the object receives the value 1, this means the user is present. <p>For further information, see: Presence detection.</p>				

4.3.11 Thermostat deactivation

No.	Name	Function of the object	Data type	Flags
259, 358, 457, 556, 655, 754, 853, 952, 1051, 1150, 1249, 1348	Thermostat x	Lock-up additional step	1 - Bit - 1.001 DPT_Switch	C, R, W
<p>This object is activated if the Function selection parameter has the value Basic and additional heating or Basic and additional cooling or Basic and additional heating and cooling. This object is used to lock the heating and additional cooling.</p> <p>Object value: Depends on the Polarity parameter.</p> <p>ON = 1</p> <ul style="list-style-type: none"> - If the object receives value 0, the additional step function is deactivated. - If the object receives value 1, the additional step function is activated. <p>ON = 0</p> <ul style="list-style-type: none"> - If the object receives value 0, the additional step function is activated. - If the object receives value 1, the additional step function is deactivated. <p>For further information, see: Thermostat deactivation.</p>				

No.	Name	Function of the object	Data type	Flags
260, 359, 458, 557, 656, 755, 854, 953, 1052, 1151, 1250, 1349	Thermostat x	Heating deactivation	1 - Bit - 1.003 DPT_Enable	C, R, W
<p>This object is activated if the Function selection parameter has the value Chauffage or Heating/Cooling or basic and additional heating or Basic and additional heating and cooling. This object is used to activate or deactivate the heating function.</p> <p>Object value: Depends on the Polarity parameter.</p> <p>ON = 1</p> <ul style="list-style-type: none"> - If the object receives the value 1, the Heating function is inactive. - If the object receives the value 0, the Heating function is active. <p>ON = 0</p> <ul style="list-style-type: none"> - If the object receives the value 1, the Heating function is active. - If the object receives the value 0, the Heating function is inactive. <p>For further information, see: Thermostat deactivation.</p>				

No.	Name	Function of the object	Data type	Flags
261, 360, 459, 558, 657, 756, 855, 954, 1053, 1152, 1251, 1350	Thermostat x	Cooling deactivation	1 - Bit - 1.003 DPT_Enable	C, R, W
<p>This object is activated if the Function selection parameter has the value Cooling or Heating/Cooling or Basic and additional cooling or Basic and additional heating and cooling. This object is used to activate or deactivate the cooling function.</p> <p>Object value: Depends on the Polarity parameter.</p> <p>ON = 1</p> <ul style="list-style-type: none"> - If the object receives the value 1, the Cooling function is inactive. - If the object receives the value 0, the Cooling function is active. <p>ON = 0</p> <ul style="list-style-type: none"> - If the object receives the value 1, the Cooling function is active. - If the object receives the value 0, the Cooling function is inactive. <p>For further information, see: Thermostat deactivation.</p>				

No.	Name	Function of the object	Data type	Flags
262, 361, 460, 559, 658, 757, 856, 955, 1054, 1153, 1252, 1351	Thermostat x	Heating deactivation status	1 - Bit - 1.003 DPT_Enable	C, R, W
<p>This object is activated if the Function selection parameter has the value Chauffage or Heating/Cooling or basic and additional heating or Basic and additional heating and cooling. This object is used to send the heating function status of the device on the KNX bus.</p> <p>Object value:</p> <ul style="list-style-type: none"> - If the heating function is deactivated, a telegram with a logic value 1 is sent. - If the heating value is activated, a telegram with a logic value 0 is sent. <p>This object is sent when there is a status change. For further information, see: Thermostat deactivation.</p>				

No.	Name	Function of the object	Data type	Flags
263, 362, 461, 560, 659, 758, 857, 956, 1055, 1154, 1253, 1352	Thermostat x	Cooling deactivation status	1 - Bit - 1.003 DPT_Enable	C, R, T
<p>This object is activated if the Function selection parameter has the value Cooling or Heating/Cooling or Basic and additional cooling or Basic and additional heating and cooling.</p> <p>This object is used to send the cooling function status of the device on the KNX bus.</p> <p>Object value:</p> <ul style="list-style-type: none"> - If the cooling function is deactivated, a telegram with a logic value 1 is sent. - If the cooling function is activated, a telegram with a logic value 0 is sent. <p>This object is sent when there is a status change.</p> <p>For further information, see: Thermostat deactivation.</p>				

No.	Name	Function of the object	Data type	Flags
264, 363, 462, 561, 660, 759, 858, 957, 1056, 1155, 1254, 1353	Thermostat x	Thermostat deactivation	1 - Bit - 1.003 DPT_Enable	C, R, W
<p>This object is activated if the Thermostat deactivation parameter has the value Through object.</p> <p>This object is used to deactivate the regulator thermostat.</p> <p>Object value: Depends on the Polarity parameter.</p> <p>ON = 1</p> <ul style="list-style-type: none"> - If the object receives the value 1, the thermostat is inactive. - If the object receives the value 0, the thermostat is active. <p>ON = 0</p> <ul style="list-style-type: none"> - If the object receives the value 1, the thermostat is active. - If the object receives the value 0, the thermostat is inactive. <p>This object is sent when there is a status change.</p> <p>For further information, see: Thermostat deactivation.</p>				

No.	Name	Function of the object	Data type	Flags
265, 364, 463, 562, 661, 760, 859, 958, 1057, 1156, 1255, 1354	Thermostat x	Status indication thermostat deactivation	1 - Bit - 1.003 DPT_Enable	C, R, T
<p>This object is activated if the Thermostat deactivation parameter has the value Through object.</p> <p>This object is used to send the thermostat status of the device on the KNX bus.</p> <p>Object value:</p> <ul style="list-style-type: none"> - If the thermostat is deactivated, a telegram with a logic value 1 is sent. - If the thermostat is activated, a telegram with a logic value 0 is sent. <p>This object is sent when there is a status change.</p> <p>For further information, see: Thermostat deactivation.</p>				

4.3.12 Timer

No.	Name	Function of the object	Data type	Flags
266, 365, 464, 563, 662, 761, 860, 959, 1058, 1157, 1256, 1355	Thermostat x	Timer	1 - Bit - 1.010 DPT_Start	C, R, W

This object is activated when the **Timer** parameter is active.
 This object is used to activate the Timer function of the device via the KNX bus.

Object value:

- If a rising edge (0 to 1) arrives at this object, the heating or cooling mode is activated for a given period.
- If a falling edge (1 to 0) arrives at this object, the heating or cooling mode remains in its current status.

Note: The timer duration can be interrupted by a long press on the button controlling the timer.

Note: When a start command is received during the timer, the timer duration is reset.

For further information, see: [Timer](#).

No.	Name	Function of the object	Data type	Flags
267, 366, 465, 564, 663, 762, 861, 960, 1059, 1158, 1257, 1356	Thermostat x	Timer duration	3 - Byte - 10.001 DPT_TimeOfDay	C, R, W

This object is activated if the **Timer** parameter is active and if the **Timer duration modifiable through object** parameter is active.
 This object can be used to configure the timer duration. The timer duration can thus be configured in accordance with a time of day.

Object value:

Byte 3 (MSB)				Byte 2				Byte 1 (LSB)															
Hours				Minutes				Seconds															
0	0	0	T	T	T	T	T	0	0	M	M	M	M	M	M	0	0	W	W	W	W	W	W

Fields	Code	Value	Units
Hours	Binary	0 to 23 (5 bit)	Hours
Minutes	Binary	0 to 59 (6 bit)	Minutes
Seconds	Binary	0 to 59 (6 bit)	Seconds

For further information, see: [Timer](#).

No.	Name	Function of the object	Data type	Flags												
268, 367, 466, 565, 664, 763, 862, 961, 1060, 1159, 1258, 1357	Thermostat x	Setpoint selection during timer	1 - Byte - 20.102 DPT_HVACMode	C, R, W												
<p>This object is activated if the Timer parameter is active and if the Setpoint selection during timer modifiable through object parameter is active.</p> <p>This object is used to set the heating or cooling mode for the timer. If the heating mode is modified during the timer, the new mode will be taken into account with the next timer is started.</p> <p>Object value:</p> <table border="1" data-bbox="411 607 1173 801"> <thead> <tr> <th>Heating mode</th> <th>Value</th> </tr> </thead> <tbody> <tr> <td>Auto</td> <td>0</td> </tr> <tr> <td>Comfort</td> <td>1</td> </tr> <tr> <td>Standby</td> <td>2</td> </tr> <tr> <td>Night setpoint</td> <td>3</td> </tr> <tr> <td>Frost/heat protection</td> <td>4</td> </tr> </tbody> </table> <p>For further information, see: Timer.</p>					Heating mode	Value	Auto	0	Comfort	1	Standby	2	Night setpoint	3	Frost/heat protection	4
Heating mode	Value															
Auto	0															
Comfort	1															
Standby	2															
Night setpoint	3															
Frost/heat protection	4															

4.3.13 Preset

No.	Name	Function of the object	Data type	Flags
269, 368, 467, 566, 665, 764, 863, 962, 1061, 1160, 1259, 1358	Thermostat x	Preset 1	1 - Bit - 1.003 DPT_Enable	C, R, W
<p>This object is activated when the Preset parameter is active.</p> <p>This object is used to modify the heating or cooling mode from a simple control (ON/OFF). The modes are predefined and configurable.</p> <p>Object value:</p> <ul style="list-style-type: none"> - If the object receives the value 0, the heating or cooling mode for a preset 1 = 0 is applied. - If the object receives the value 1, the heating or cooling mode for a preset 1 = 1 is applied. <p>For further information, see: Preset.</p>				

No.	Name	Function of the object	Data type	Flags
270, 369, 468, 567, 666, 765, 864, 963, 1062, 1161, 1260, 1359	Thermostat x	Preset 2	1 - Bit - 1.003 DPT_Enable	C, R, W
<p>This object is activated when the Preset parameter is active.</p> <p>See object No. 269.</p>				

No.	Name	Function of the object	Data type	Flags
271, 370, 469, 568, 667, 766, 865, 964, 1063, 1162, 1261, 1360	Thermostat x	Preset 1 authorization	1 - Bit - 1.003 DPT_Enable	C, R, W
<p>This object is activated when the Preset parameter is active and when the Preset authorization objects parameter is active.</p> <p>This object allows the authorization or lock-up of the Preset 1 function via a KNX telegram.</p> <p>Object value: This is dependent on the Polarity of autorisation object Preset 1 parameter.</p> <p>0 = Locked-up, 1 = Authorized</p> <ul style="list-style-type: none"> - If the object receives the value 0, Preset 1 is deactivated. - If the object receives the value 1, Preset 1 is activated. <p>0 = Authorized, 1 = Locked-up</p> <ul style="list-style-type: none"> - If the object receives the value 0, Preset 1 is activated. - If the object receives the value 1, Preset 1 is deactivated. <p>For further information, see: Preset.</p>				

No.	Name	Function of the object	Data type	Flags
272, 371, 470, 569, 668, 767, 866, 965, 1064, 1163, 1262, 1361	Thermostat x	Preset 2 authorization	1 - Bit - 1.003 DPT_Enable	C, R, W
See object No. 271.				

4.3.14 Lock-up

No.	Name	Function of the object	Data type	Flags
273, 372, 471, 570, 669, 768, 867, 966, 1065, 1164, 1263, 1362	Thermostat x	Lock-up 1	1 - Bit - 1.003 DPT_Enable	C, R, W
<p>This object is activated if the Lock-up parameter has the value Active and if the Number of lock-up objects parameter has the value 1 or 2.</p> <p>This object is used to control the activation of the lock-up via the KNX bus.</p> <p>Object value: This is dependent on the Polarity of lock-up object 1 parameter.</p> <p>0 = Lock-up activated, 1 = Lock-up deactivated</p> <ul style="list-style-type: none"> - If the object receives value 0, the Lock-up is activated. - If the object receives value 1, the Lock-up is deactivated. <p>0 = Lock-up deactivated, 1 = Lock-up activated</p> <ul style="list-style-type: none"> - If the object receives value 0, the Lock-up is deactivated. - If the object receives value 1, the Lock-up is activated. <p>For further information, see: Lock-up.</p>				

No.	Name	Function of the object	Data type	Flags
274, 373, 472, 571, 670, 769, 868, 967, 1066, 1165, 1264, 1363	Thermostat x	Lock-up 2	1 - Bit - 1.003 DPT_Enable	C, R, W
<p>This object is activated if the Lock-up parameter has the value Active and if the Number of lock-up objects has the value 2.</p> <p>See object No. 273.</p>				

No.	Name	Function of the object	Data type	Flags
275, 374, 473, 572, 671, 770, 869, 968, 1067, 1166, 1265, 1364	Thermostat x	Status indication lock-up	1 - Bit - 1.003 DPT_Enable	C, R, T
<p>This object is activated when the Activation of lock-up status object parameter is active. This object allows the status of the lock-up to be sent from the device over the KNX bus.</p> <p>Object value: Depends on the Polarity parameter. 0 = Lock-up deactivated, 1 = Lock-up activated</p> <ul style="list-style-type: none"> - If the lock-up is deactivated, a telegram with logic value 0 is sent on the KNX bus. - If the lock-up is activated, a telegram with logic value 1 is sent on the KNX bus. <p>0 = Lock-up activated, 1 = Lock-up deactivated</p> <ul style="list-style-type: none"> - If the lock-up is activated, a telegram with logic value 0 is sent on the KNX bus. - If the lock-up is deactivated, a telegram with logic value 1 is sent on the KNX bus. <p>This object is sent periodically and/or on status change.</p> <p>For further information, see: Lock-up.</p>				

4.3.15 Valve protection

No.	Name	Function of the object	Data type	Flags
276, 375, 474, 573, 672, 771, 870, 969, 1068, 1167, 1266, 1365	Thermostat x	Valve protection date	3 - Byte - 11.001 DPT_Date	C, R, W

This object is activated when the **Valve protection** parameter is active and the **Valve protection activation** parameter has the value **Periodically at specific time**.

This object is used to define the valve protection date for the device by the KNX bus.

Only valves controlled by this thermostat are concerned.

Object value:

Byte 3 (MSB)					Byte 2				Byte 1 (LSB)														
Day					Month				Year														
0	0	0	D	D	D	D	D	0	0	0	0	M	M	M	M	0	Y	Y	Y	Y	Y	Y	Y

Fields	Code	Value	Units
Day	Binary	1 to 31 (5 bit)	Day
Month	Binary	1 to 12 (4 bit)	Month
Year	Binary	0 to 99 (7 bit)	Year

For further information, see: [Valve protection](#).

No.	Name	Function of the object	Data type	Flags
277, 376, 475, 574, 673, 772, 871, 970, 1069, 1168,	Thermostat x	Valve protection time	3 - Byte - 10.001 DPT_TimeOfDay	C, R, W

This object is activated when the **Valve protection** parameter is active and the **Valve protection activation** parameter has the value **Periodically at specific time**.

This object is used to define the valve protection time for the device by the KNX bus.

Only valves controlled by this thermostat are concerned.

Object value:

Byte 3 (MSB)				Byte 2				Byte 1 (LSB)															
Day		Hours		Minutes				Seconds															
D	D	D	T	T	T	T	T	0	0	M	M	M	M	M	M	0	0	W	W	W	W	W	W

Fields	Code	Value	Units
Day	Binary	0 = Any day 1 = Monday ... 7 = Sunday (3 bit)	
Hours	Binary	0 to 23 (5 bit)	Hours
Minutes	Binary	0 to 59 (6 bit)	Minutes
Seconds	Binary	0 to 59 (6 bit)	Seconds

For further information, see: [Valve protection](#).

No.	Name	Function of the object	Data type	Flags
278, 377, 476, 575, 674, 773, 872, 971, 1070, 1169, 1268, 1367	Thermostat x	Valve protection date and time	8 - Byte - 19.001 DPT_DateTime	C, R, W

This object is activated when the **Valve protection** parameter is active and the **Valve protection activation** parameter has the value **Periodically at specific time**.

This object is used to define the valve protection date and time for the device by the KNX bus.

Only valves controlled by this thermostat are concerned.

Object value:

Byte 8 (MSB)	Byte 7	Byte 6	Byte 5
Year	Month	Day of the month	Weekday Hours
Y Y Y Y Y Y Y Y	0 0 0 0 M M M M	0 0 0 D D D D D	D D D T T T T T

Byte 4	Byte 3	Byte 2	Byte 1 (LSB)
Minutes	Seconds	D DW DW YV DV WD TV SW CA	
0 0 M M M M M M	0 0 W W W W W W	B B B B B B B	B 0 0 0 0 0 0 0

Fields	Code	Value	Units
Year	Binary	0 (1900) to 255 (2155) (8 bit)	Year
Month	Binary	1 to 12 (4 bit)	Month
Day of the month	Binary	1 to 31 (5 bit)	Day
Day of the week	Binary	0 = Any day	
	Binary	1 = Monday ... 7 = Sunday (3 bit)	
Hours	Binary	0 to 23 (5 bit)	Hours
Minutes	Binary	0 to 59 (6 bit)	Minutes
Seconds	Binary	0 to 59 (6 bit)	Seconds
Error (D)	Binary	0 = No error or 1 = Error (1 bit)	
Day Worked (DW)	Binary	0 = Day Worked or 1 = Holiday (1 bit)	
DWV (DWV)	Binary	0 = Day Worked valid or 1 = Invalid DW (1 bit)	
Year Validated (YV)	Binary	0 = Year valid or 1 = Invalid year (1 bit)	
DV (DV)	Binary	0 = Date valid or 1 = Invalid date (1 bit)	
Weekday validated (WDV)	Binary	0 = Day valid or 1 = Invalid day (1 bit)	
Time Validated (TV)	Binary	0 = Time valid or 1 = Invalid time (1 bit)	
Summer/Winter Period (SWP)	Binary	0 = standard time or 1 = Summertime (1 bit)	
Clock Accuracy (CA)	Binary	0 = No external synchronisation or 1 = External synchronisation (1 bit)	

For further information, see: [Valve protection](#).

No.	Name	Function of the object	Data type	Flags
279, 378, 477, 576, 675, 774, 873, 972, 1071, 1170, 1269, 1368	Thermostat x	Valve protection duration	2 - Byte - 7.006 DPT_TimePeriodMin	C, R, W
<p>This object is activated when the Valve protection parameter is active. This object is used to define the valve protection duration for the device by the KNX bus. Only valves controlled by this thermostat are concerned.</p> <p>Object value: 0 min ... 65 535 min (Corresponds to approximately 45.5 days) Units: minute Resolution: 1 min</p> <p>For further information, see: Valve protection.</p>				

No.	Name	Function of the object	Data type	Flags
280, 379, 478, 577, 676, 775, 874, 973, 1072, 1171, 1270, 1369	Thermostat x	Valve protection periodicity	2 - Byte - 7.007 DPT_TimePeriodHrs	C, R, W
<p>This object is activated when the Valve protection parameter is active and the Valve protection activation parameter has the value Periodically or Periodically at specific time. This object is used to define the valve protection periodicity for the device by the KNX bus. Only valves controlled by this thermostat are concerned.</p> <p>Object value: 0 h ... 65 535 h (Corresponds to approximately 7.4 years) Units: time Resolution: 1 h</p> <p>For further information, see: Valve protection.</p>				

No.	Name	Function of the object	Data type	Flags
281, 380, 479, 578, 677, 776, 875, 974, 1073, 1172, 1271, 1370	Thermostat x	Valve protection start/stop	1 - Bit - 1.010 DPT_Start	C, R, W
<p>This object is activated when the Valve protection parameter is active and the Valve protection activation parameter has the value Through object.</p> <p>This object is used to control activation of valve protection for the valve outputs in question by the KNX bus.</p> <p>Object value: It depends on the Object valve protection start/stop polarity parameter.</p> <p>1 = Start, 0 = Stop</p> <ul style="list-style-type: none"> - If the object receives the value 1, valve protection starts. - If the object receives the value 0, valve protection stops. <p>1 = Stop, 0 = Start</p> <ul style="list-style-type: none"> - If the object receives the value 1, valve protection stops. - If the object receives the value 0, valve protection starts. <p>For further information, see: Valve protection.</p>				

5 Appendix

5.1 Specifications

Média KNX	TP1-256
Supply voltage KNX	21...32 V _{DC} SELV
Supply voltage of the product and the valves	230 V _~ +10/-15 % 50/60 Hz 240 V _~ +/-6 % 50/60 Hz 24 V _~ +/- 5 % 50/60 Hz
Surge voltage	4 kV
Protection switch	16 A
Operating altitude	max.2000 m
Degree of contamination	2
Heat class	2
Operating temperature	-5° ... +45°C
Current consumption KNX	typ. 18.5 mA
Dimension	4 TE, 4 x 17.5 mm
Action type	2Y
Voltage and current signalled for EMC testing of interference radiation	230 V _~ 1 A/24 V _~ 1 A
Power loss	max. 2.7 W

5.2 Table of logical operations

Input 4	Input 3	Input 2	Input 1	OR	AND
-	-	0	0	0	0
-	-	0	1	1	0
-	-	1	0	1	0
-	-	1	1	1	1
-	0	0	0	0	0
-	0	0	1	1	0
-	0	1	0	1	0
-	0	1	1	1	0
-	1	0	0	1	0
-	1	0	1	1	0
-	1	1	0	1	0
-	1	1	1	1	1
0	0	0	0	0	0
0	0	0	1	1	0
0	0	1	0	1	0
0	0	1	1	1	0
0	1	0	0	1	0
0	1	0	1	1	0
0	1	1	0	1	0
0	1	1	1	1	0
1	0	0	0	1	0
1	0	0	1	1	0
1	0	1	0	1	0
1	0	1	1	1	0
1	1	0	0	1	0
1	1	0	1	1	0
1	1	1	0	1	0
1	1	1	1	1	1

5.3 Characteristics

Device	TYMS646T	TYMS646R
Max. number of group addresses	3568	3568
Max. number of allocations	3569	3569
Objects	203	1391

Hager Controls
BP10140
67703 Saverne Cedex, France
T +33 (0) 3 88 02 87 00
info@hager.com
hager.com