

(DE)	Montageanleitung	(HR)	Upute za montažu
(FR)	Notice d'instructions	(HU)	Szerelési útmutató
(GB)	Mounting instructions	(LT)	Montavimo instrukcija
(NL)	Montage instructie	(LV)	Montāžas instrukcija
(DK)	Monteringsvejledning	(PL)	Instrukcja montażowa
(FI)	Asennusohje	(RO)	Intruțiuni de montare
(NO)	Montasjeanvisning	(SK)	Návod na montáž
(SE)	Monterings instruktioner	(RU)	Указания по установке
(IT)	Istruzioni di montaggio	(BG)	Инструкции за монтаж
(ES)	Instrucciones de montaje	(GR)	Οδηγίες χώνευσης
(PT)	Instruções de montagem	(SI)	Navodilo za montažo
(CZ)	Montážní návod	(EE)	Paigaldusjuhised
(BA)	Uputstvo za montažu	(IS)	Leiðbeiningar
(UK)	Інструкції з установки	(AR)	دليل التركيب

Feldschienen Längstrennung / Stromwandler Einbau
Sectionnement longitudinale des barres omnibus /
Montage transformateur d'intensité
Bus bar sectionalization / Current transformer installation

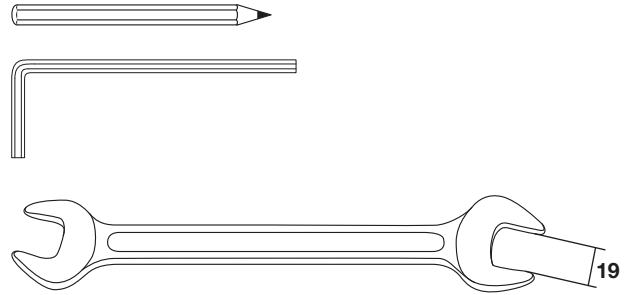

19

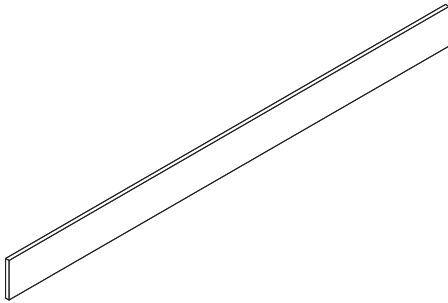
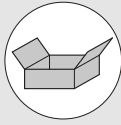