

(GB)

**RE..610..**

Video module 2-wire

**RE..510..**

Video insert replacement 2-wire

**Safety instructions**

Electrical equipment may only be installed and assembled by a qualified electrician in accordance with the relevant installation standards, guidelines, regulations, directives, safety and accident prevention regulations of the country.

When installing and laying cables, always comply with the applicable regulations and standards for SELV electrical circuits.

These instructions are an integral component of the product and must be retained by the end user.

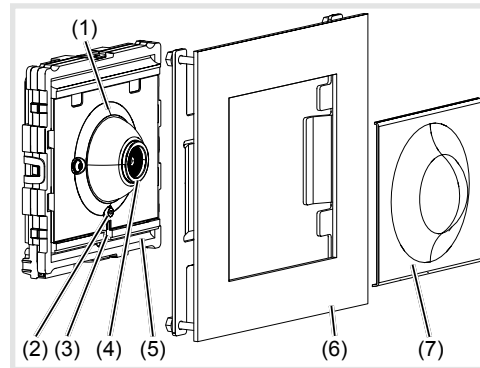
**Design and layout of the device**

Figure 1: Front video module

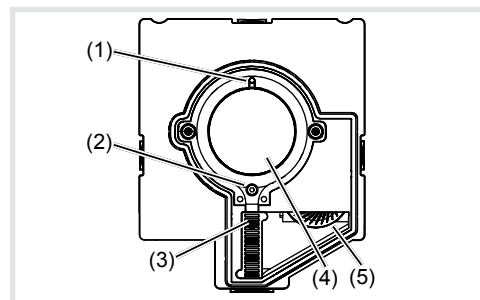


Figure 2: Front video insert

- (1) Microphone
- (2) Locating screw for camera (Allen key supplied)
- (3) Twilight sensor for call button
- (4) Camera
- (5) Loudspeaker openings
- (6) Module carrier (according to reference)
- (7) Centre plate (only with video modules)

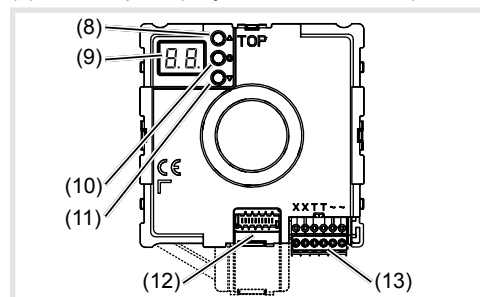


Figure 3: Back

- (8) Adjustment button Upwards ▲
- (9) 7-segment display
- (10) Selection button ○
- (11) Adjustment button downwards ▼
- (12) Connection for module connecting cable
- (13) Connection terminal block

**Function**

The device works in the 2-wire bus system and enables communication via sound and image.

**Correct use**

- for surface-mounted, flush-mounted or built-in installation
- Not compatible with intercom systems of other manufacturers
- suitable for use exterior applications

**Product characteristics**

- One-man commissioning
- expandable for modules, e.g. call push-button
- Call push-button acknowledge tone (can be switched off)
- Call button, light release or door release can be adjusted even without any function
- Switch-on brightness level of the call button backlighting adjustable
- Colour camera
- invisible, glare-free IR LED night lighting
- temperature controlled camera heating for clear view
- scratch-proof camera cover
- Loudspeaker and microphone protected against sabotage
- Volume and microphone sensitivity settable
- Door release contact on 1 ... 10 s adjustable
- Door release without previous call adjustable in single door systems

**Operation of call push-buttons**

Call push-buttons are connected to the device.

**Establish call (ringing)**

- Press the call push-button assigned to the desired subscriber.

If configured, the call push-button activation is confirmed by an acknowledge tone. Addressed indoor stations are called.

**Switch-on lights**

A call push-button is configured and labelled for lighting control.

- Press the call push-button for lighting.

If configured, the call push-button activation is confirmed by an acknowledge tone. The light contact of a line power supply is closed for the set time.

**Label call push-button**

- Keep call push-button pressed on one side. On the opposite side, the lever opening (14) is accessible for a screwdriver.
- Position the screwdriver in the lever opening (14) and release the interlock (Figure 4).
- Remove cover with name plate insert.

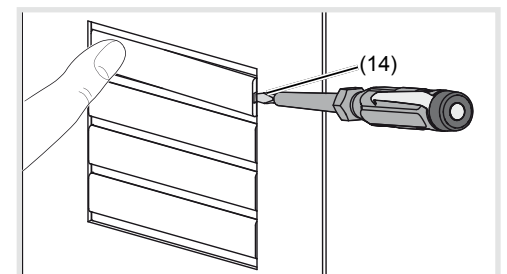


Figure 4: Removing name plate cover

**(14) Lever opening**

- Label name plate insert if required.
- Insert name plate insert, prepared foil or prepared labelling strip into the cover.
- Press on cover.

**B** Do not use any paper for the name plate insert, since moisture and UV light will damage the paper and labelling.

**I** UV-resistant foil with laser printing is suitable for labelling as well as labelling devices for labelling strip:

- small buttons - 12 mm
- medium buttons - 30 mm

Detailed labelling references are to be found on our homepage.

### Door stations with status indication

Display	Cause	Function/Lighting duration
	A subscriber is called.	After 90 s without call acceptance or an operation on the door station,  goes out.
	A subscriber accepts the door call.	goes out,  lights up as long as the intercom connection is pressed down, max. 3 min.
	The door is unlocked.	Call not accepted: Symbol goes out and  lights up for the unlocking time set on the door station. Call accepted: In addition to the , the  lights up for the unlocking time set on the door station.  goes out approx. 5 sec after the  symbol.

Table 1: Status indications of door station

## Information for electricians

### Installation and electrical connection



#### DANGER!

Touching live parts in the installation environment can result in an electric shock!

An electric shock can be lethal!

Before working on the device or load, disconnect all associated circuit breakers. Cover all live parts in the area!

When installing door communication systems, comply with the general safety regulations for telecommunications systems according to VDE 0800:

- Separate routing of power and door communication cables with a minimum spacing of 10 cm
- Partitions between power and door communication cables in shared cable ducts
- Use of standard telecommunications' cables, e.g. J-Y (St) Y with 0.8 mm diameter

### Bus cables

- J-Y(ST)Y or A-2Y(L)2Y  
Use wrapped wire pair.  
Recommendation white/yellow
- CAT  
Use wrapped wire pair  
Recommendation orange/white
- YR  
Use adjacent wires

### Installing the appliance

**I** An installation height of approx. 1.5 m (middle of the camera lens) is recommended for persons of average size.

**I** Installation of the device depends upon the respective product it is going to be installed in (see installation instruction, e.g. door station, frame, etc.).

### Connect device

The connection cables and indoor stations are connected to the line power supply while taking the maximum cable lengths and attenuations into account (see operating instructions of the line power supply).

- Bring pre-assembled station (door station, frame, etc.) in installation position - if necessary with safety rope and tools.
- Shorten connection cable of the station as required and strip the required wires.
- Pull off connection terminal block (13) from the device.
- Connect the wire pair of the 2-wire bus cable to the terminals **XX** of the connection terminal block (Figure 5).
- Connect door release to the terminals **TT** of the connection terminal block (figure 5 and 6) if required.

or:

- For manipulation-protected installation, connect the door release to the contact of the line power supply (Figure 7).

**I** The door release lead must not be inserted through the door station in order to protect against manipulation.

- For call push-button backlighting and camera heating connect 12 V~ lead from the power transformer to the terminals **~** of the connection terminal block (Figure 5 ... 7).

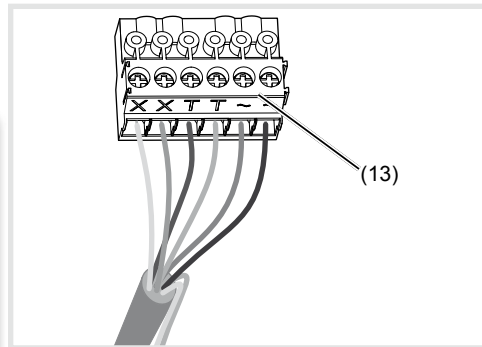


Figure 5: Wired connection terminal block

- Attach connector of the module connection cable to the next call push-button module on the device.
- Attach connection terminal block to the device.
- Engage and screw in the module e.g. in the rear latching receptacle of a door station (see corresponding mounting instructions).
- Close station.

### Circuit symbols and elements of the circuit diagrams



Line power supply RMD



Power transformer



Door release



Video door station



Wrapped wire pair for 2-wire devices (recommendation: white/yellow wire pair)



Unwrapped wire pair, for e.g. for door release

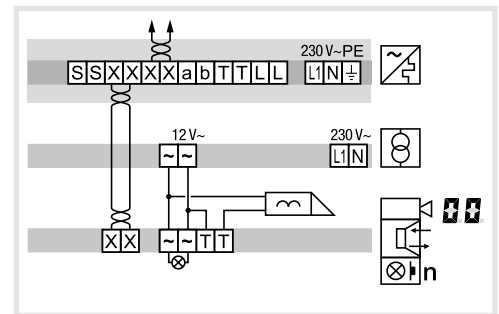


Figure 6: Door release connection on the door station

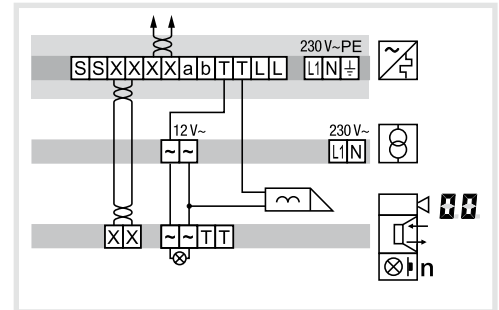


Figure 7: Connection of door station video with manipulation-protected door release

### Calling up and changing of system settings

On the back of the device, there are 3 buttons and a 2-digit 7-segment display (Figure 3, 8 ... 11) for the system settings.

- Press / button.  
Device turns to setting mode. The first menu entry is displayed.
- I** The reading directions of the 7-segment display varies by 180° depending on which button / you start with.
- Select the desired menu entry with / (figure 9).
- Confirm the selection with .
- I** The 7 segments display goes dark if there is no actuation for 5 seconds. Settings are applied. The device returns to normal operation.

### Setting the values

The menu entry to be set is confirmed and flashes alternately with the value to be set.

- Press / button.  
Short button-press: change the value by one step.  
Long button-press: run through values. Scrolling stops when the button is released.
  - Confirm set value with .
- The device applies the setting and returns to the previous menu entry.

### Address call push-button automatically

The call push-button and connector on the back are addressed by the automatic call push-button addressing as follows. The addressing, e.g. with two-rowed door stations, takes place starting from the top downwards, and with a two-rowed door station, counterclockwise automatically upwards to the right (figure 8).

The menu entry **AA** is selected. **AA** flashes alternately with the entry for cancel.

- With / select the entry for automatic addressing.
  - Confirm with .
- During the addressing, the display flickers. Afterwards the display returns to the previous menu entry **AA**.

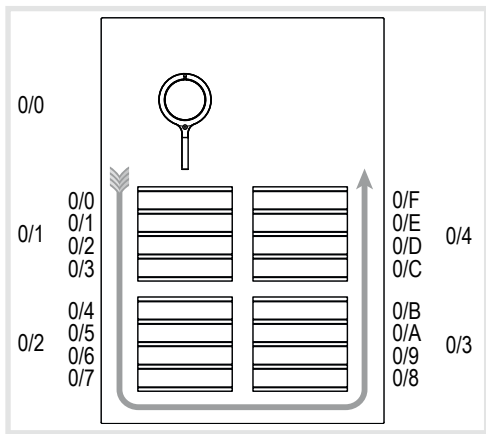
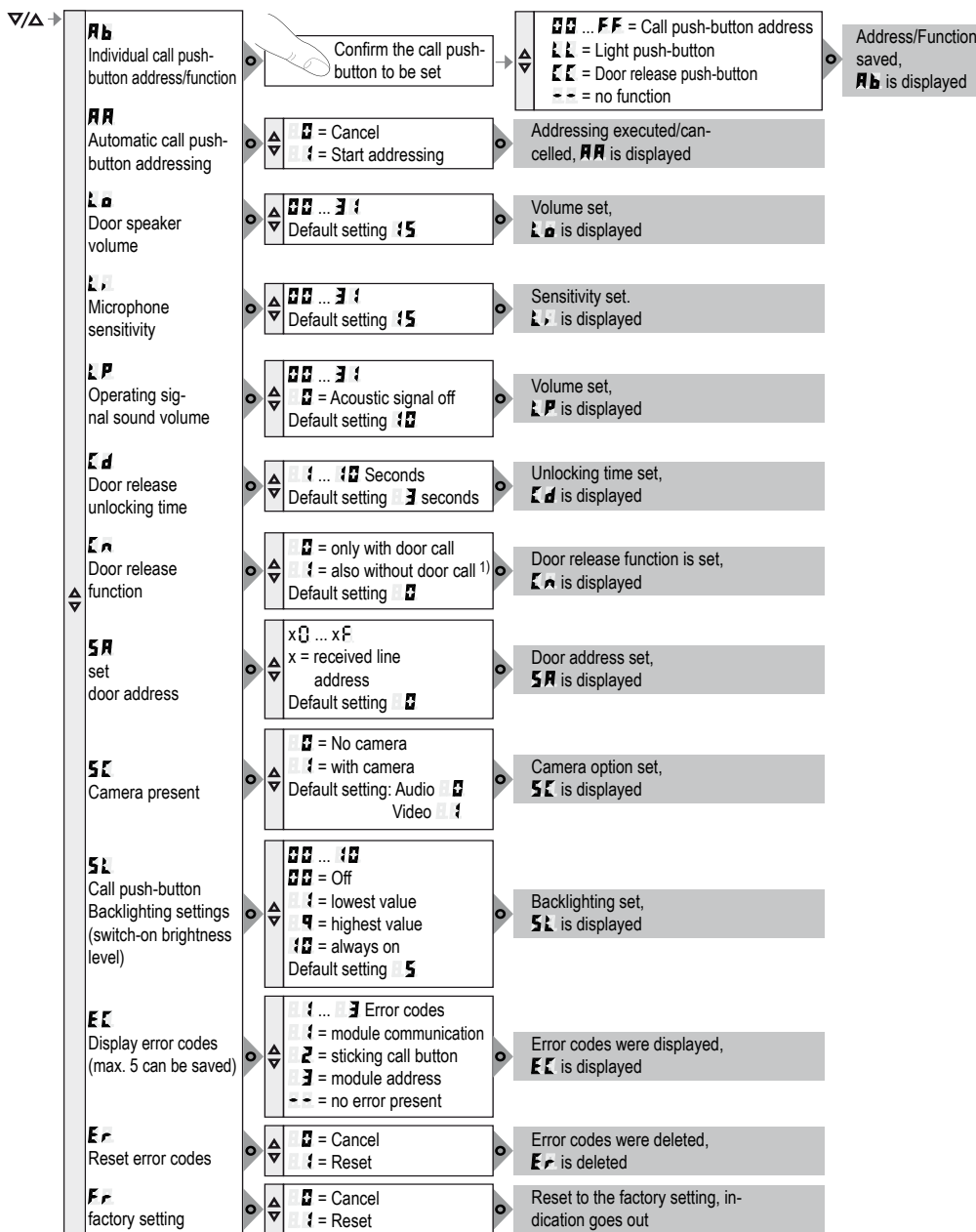


Figure 8: Module address and automatic call push-button addressing

### Set individual call push-button address/function

The menu entry **Ab** Set individual call push-button address/function is selected and flashes.

- Confirm the call push-button to be set.



1) Door release functions without door call only possible single door systems

Figure 9: Overview of system settings

The menu entry **Ab** flashes alternately with the current address/function.

- With ▽ / ▽ select the required address ▽ ▽ ... ▽ ▽ or function ▽ ▽ for light push-button, ▽ ▽ for door release push-button or ▽ ▽ for no function.
- Confirm set address/function with ○.

The device applies the setting and returns to the previous menu entry **Ab**.

### Display saved error codes

Device errors that occur during operation are stored in the error memory of the device for diagnosis.

- Select menu entry **Ee** with button ▽ / ▽ and confirm with ○.

If no error code exists ▽ ▽ is displayed for 2 seconds and afterwards **Ee**.

If error codes are saved **Ee** flashes followed by the module address and the error code.

- Press button ▽ / ▽, to call up further error codes if necessary.
- Press button ○ to return to menu entry **Ee**.

Error code	Error cause	Counter actions
▽ ▽	Communication error between device and call push-button module. Once the error has occurred 3 times, the system is reset automatically and the error code is generated.	If the error persists, the call push-button module must be replaced.
▽ ▽	sticking call button	Check call push-button module. If there is a defect, replace and address.
▽ ▽	Writing of the call push-button address in the call push-button module fails.	If the error persists, the call push-button module must be replaced and re-addressed.

Table 2: Error codes and counter actions

The memory should only be deleted once 5 error codes have been stored, so that new error codes can be saved.

Identical error codes are only saved once.

### Align camera

The camera can be aligned in order to adapt the camera picture to the local circumstances (Figure 10 and 14).

The door station is installed.

- With door stations with video module: unlock centre plate at the dismantling opening (15) carefully with a screwdriver and remove then.

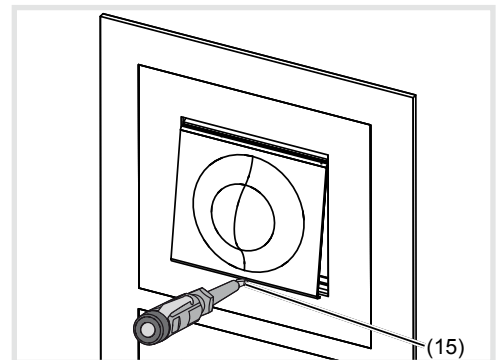


Figure 10: Dismantling video module centre plate

(15) Dismantling opening

- Loosen the locating screw (2) for the camera with the 1.5 mm Allen key supplied (Figure 11 or 12).
- Call an indoor station video from the door station by call push-button.

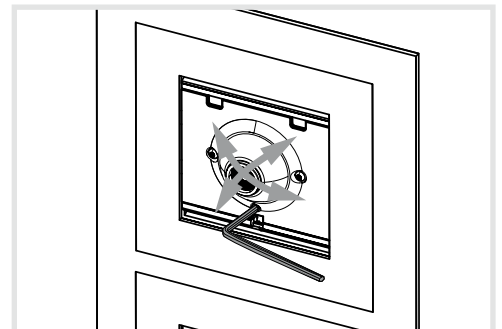


Figure 11: Camera alignment video module

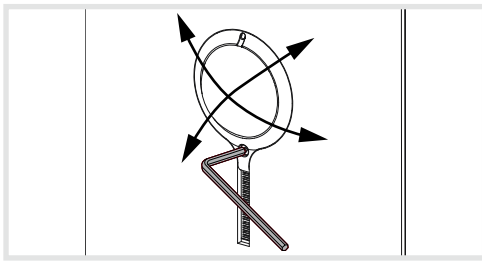


Figure 12: Camera alignment video insert

- Align camera (figure 13/14).

The entrance area is clearly visible on the display of the indoor station.

- Fix camera again with screw (2).

**B** Choose the installation location so that direct sunlight and back light are avoided, and bright lights or other light sources do not interfere with camera transmission.

**B** Backgrounds with a high level of brightness, extreme contrasts or reflections reduce the image quality.

**B** If it is dark and the camera infrared visual field illumination is on, black and white images at a range of approx. 0.7 m are transmitted. Entrance lighting above the camera enables colour images during darkness.

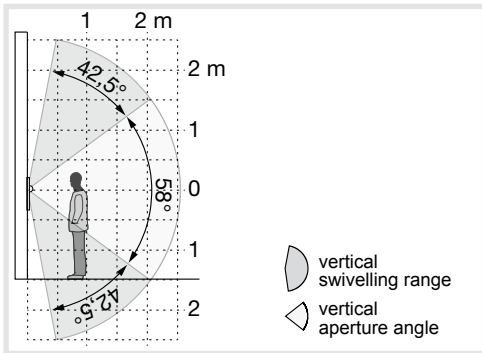


Figure 13: Vertical camera orientation

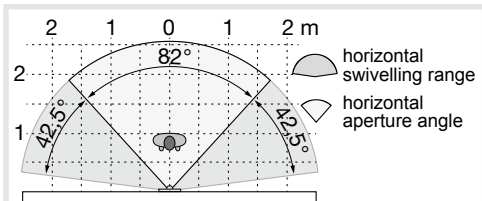


Figure 14: Horizontal camera orientation

### Dismantle call push-button module cover

For cleaning or replacement, the call push-button module cover can be dismantled from the front.

- Lever up the interlocking cover strips (16) at the top and bottom using the screwdriver and remove (Figure 15).

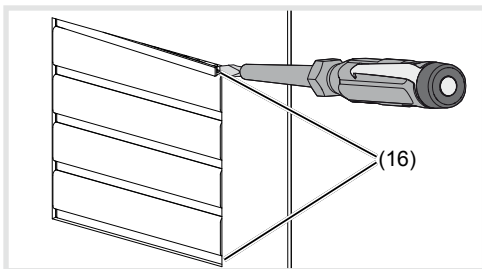


Figure 15: Removing the cover strips

### (16) Cover strips

- Lift the call push-button module upper part in the bottom lever opening slightly with the screwdriver and guide it forwards (16).

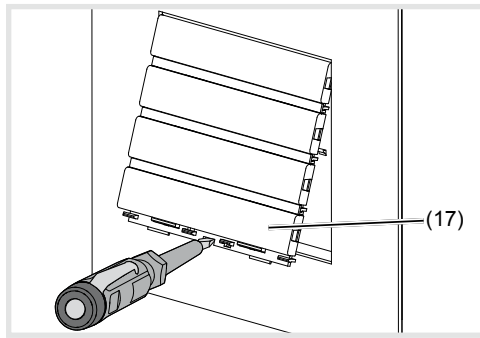


Figure 16: Dismantling the call push-button module cover

### (17) Call push-button module cover

**B** Defective covers can only be replaced by covers with the same number of push-buttons.

- Remove the module to be replaced and install the new module in reverse order.

### Exchange module/insert

Door station is open and activated.

- Pull off connection terminal block (13) on the device.
- Remove the connection cables' connectors of the module to be exchanged.
- Remove screws/nuts from mechanic module mountings and remove module mounting (see already available installation instruction, e.g. door station, frame, etc.).  
A video insert can now be removed.
- To remove the call push-button module, unlatch the side retaining brackets (18) of the module mounting by carefully lifting up with a screwdriver (Figure 17).

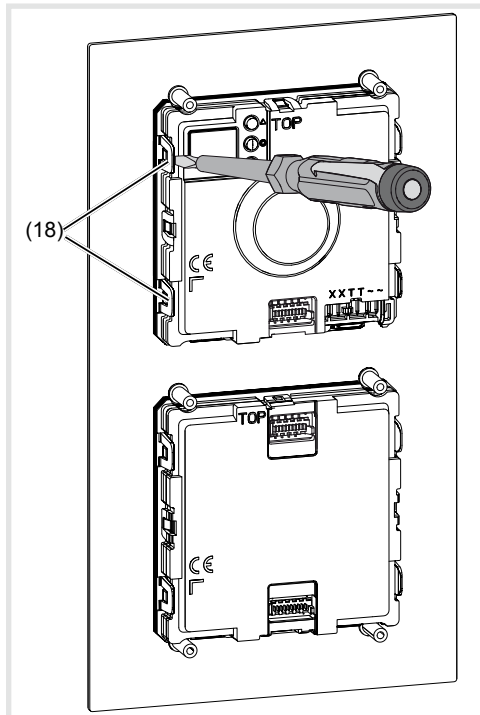


Figure 17: Unlatching module

### (18) Retaining brackets module mounting

The module detaches itself from the anchoring.

- Remove the module to be replaced and install the new module in reverse order.

**B** Re-addressing of the device is required to operate the door station.

## Appendix

### Technical data

Operating voltage	22 ... 24 V=
Current consumption camera (Stand-by)	ca. 8 mA
Current consumption camera (operation)	max. 240 mA
Current consumption camera heating (operation)	100 mA
Current name plate lighting per call push-button module	45 mA

Menu setting	Backlighting On	Backlighting Off
0	Permanent Off	
1	≈ 750 lx	≈ 1600 lx
2	.	.
3	.	.
4	.	.
5	.	.
6	.	.
7	.	.
8	.	.
9	≈ 60 lx	≈ 110 lx
10	Permanent On	

Table 3: Brightness of LED backlighting

Door release contact T/T potential-free	max. 24 V/1 A
Door release unlocking time	1 ... 10 s
Camera aperture angle horiz./vertical	82°/58°
Camera aperture angle swivelling range horizontal/vertical	42.5°
Camera resolution	500 x 582 px
Recommended camera installation height	1.5 m
Hexagon 1.5 mm camera locating screw	M2 x 10 mm
Degree of protection	IP 44
Degree of protection (degree of impact resistance)	IK07
Relative humidity	0 ... 65% (no condensation)
Operating temperature	-20°C ... +55°C
Switch on temperature camera heating	ca. 20°C
Storage/transport temperature	-30°C ... +80°C
Connecting terminals for conductor diameter	0.5 ... 0.8 mm
Dimensions:	
Call push-button button small	75.8 x 14.5 mm
Name plate small	72.1 x 12 mm
Width of name plate insert small	max. 0.5 mm
Call push-button button medium	75.8 x 32.6 mm
Name plate medium	72.1 x 30.1 mm
Width of name plate insert medium	max. 0.5 mm
Call push-button button large	75.8 x 75.8 mm
Name plate large	72.1 x 66.3 mm
Width of name plate insert large	max. 0.3 mm