

Radio hand-held transmitter mini
Order-No. : 2769

**Operation- and
Assembly Instructions**

1 Safety instructions

Electrical equipment may only be installed and fitted by electrically skilled persons.

Failure to observe the instructions may cause damage to the device and result in fire and other hazards.

Keep button cells out of reach of children! If button cells are swallowed, get medical help immediately.

Risk of explosion! Do not throw batteries into fire.

Risk of explosion! Do not recharge batteries.

These instructions are an integral part of the product, and must remain with the end customer.

2 Device components

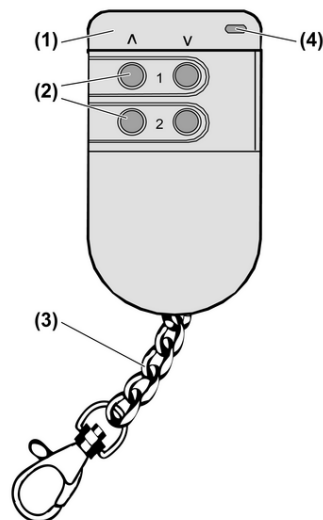

picture 1

- (1) Hand transmitter
- (2) Channel buttons
- (3) Key chain
- (4) LED

3 Function

System information

By statute, the reception characteristics and the antenna cannot be changed.

The device may be operated in all EU and EFTA countries.

The declaration of conformity can be viewed on our website.

The range of a radio system from the transmitter to the receiver depends on various circumstances.

The range of the system can be optimised by selecting the optimal installation location, taking into account the structural circumstances.

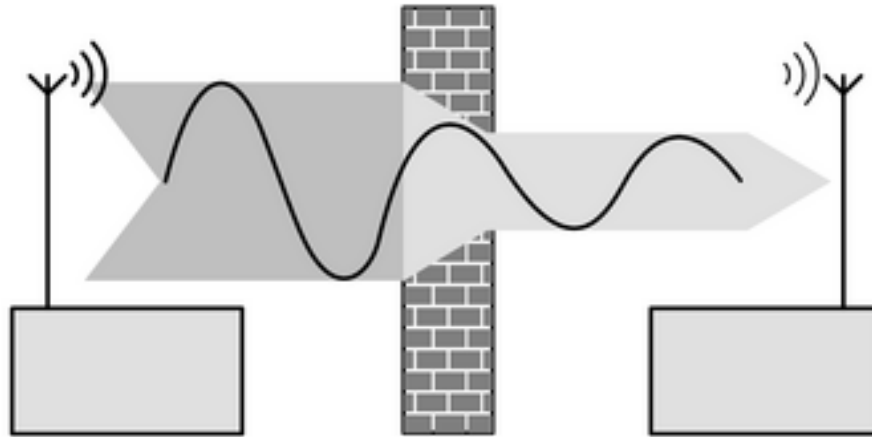

picture 2: Reduced range due to structural obstacles

Example of penetration of various materials:

Material	Penetration
Wood, Plaster, Plasterboard	approx. 90%
Brick, Chipboard	approx. 70%
Reinforced concrete	approx. 30%
Metal, Metal grid	approx. 10%
Rain, Snow	approx. 1-40%

Intended use

- Radio hand transmitter for transmission of switching, dimming, and blind movement commands
- Operation in combination with suitable radio actuators

Product characteristics

- Two channels each with two buttons
- Battery-powered device

4 Operation

Operating the transmitter

Each radio channel has two buttons. When a buttons is pressed, the red LED flashes.

The radio transmitter has been taught.

i In order to avoid faulty operation, never press more than one button at the same time.

- Press the desired button.

Receiver responds depending on the button pressed and the length of the button-press.

Channel button	Length	Lighting	Venetian blind
left Λ	less than 1 second	Switch on	Slat adjustment
left Λ	longer than 1 second	Switch on/brighter	Blind moves up
right V	less than 1 second	Switch off	Slat adjustment
right V	longer than 1 second	Switch off/darker	Blind moves down

- i** The maximum transmitting length is 12 seconds, even if the channel button is pressed longer than 12 seconds.

Change the battery

- Slacken screw on the rear of the enclosure of the hand-held transmitter and open enclosure (picture 4).
- Remove empty battery.

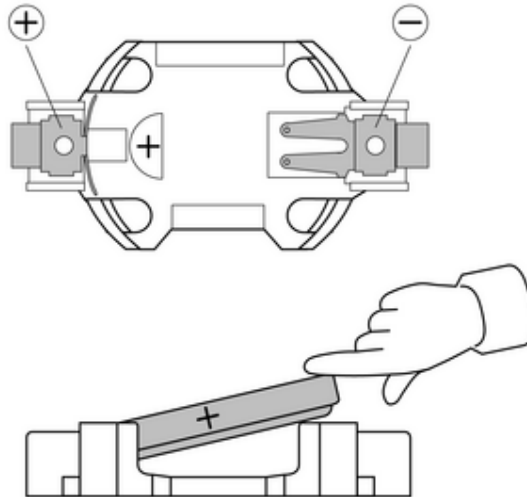

picture 3: Insert battery



WARNING!

Risk of chemical burns.

Batteries can burst and leak.

Replace batteries only with an identical or equivalent type.

- i** Keep contacts of batteries and device free of grease.
- Insert new battery. Note the correct polarity (picture 3).
 - Close enclosure and tighten screw.
 - Press any button for approx. 1 second.
The flashing LED indicates that the battery exchange was successful.

5 Information for electrically skilled persons

5.1 Fitting and electrical connection

Fitting the key chain

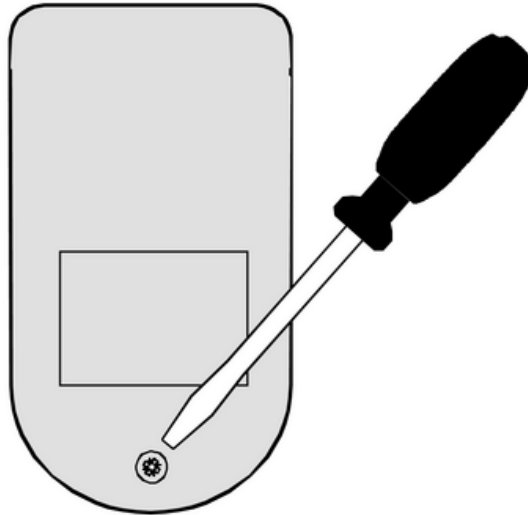

picture 4: Slacken screw

- Slacken screw on the rear of the enclosure of the hand-held transmitter and open enclosure (picture 4).

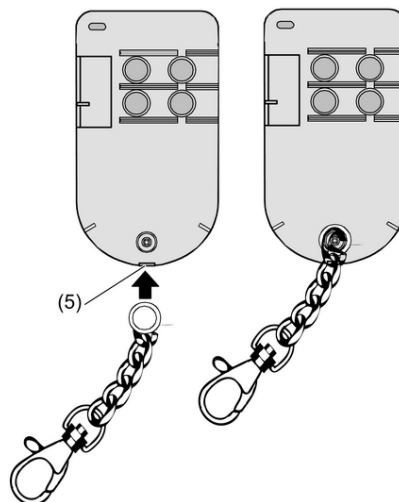

picture 5: Fitting the key chain

- Carefully remove the semicircular predetermined breaking points (5) at the front of both enclosure sections.
- Place the ring of the key chain over the screw arbour.
- Close enclosure and tighten screw.

5.2 Commissioning

Teach the channel of the radio transmitter.

In order for a receiver to understand a radio telegram of the radio transmitter, the receiver has to "learn" this radio telegram. A channel of the radio transmitter can be taught in any number of receivers. The teaching procedure only results in an assignment in the receiver.

When teaching a radio transmitter, the range of the receiver is reduced to about 5 m. The distance between the receiver and the transmitter being taught should therefore be between 0.5 m and 5 m.

- Switch radio receiver to programming mode (see instructions for radio receiver).
- Press the **A**- or **V**- button of the desired channel longer than 1 second.
The LED of the receiver lights up as an acknowledgement of the teaching procedure.
- Exit programming mode of the receiver.
The channel of the transmitter has now been taught in the radio receiver.

6 Appendix



Remove empty batteries immediately and dispose of in an environmentally friendly manner. Do not throw batteries into household waste. Consult your local authorities about environmentally friendly disposal. According to statutory provisions, the end consumer is obligated to return used batteries.

6.1 Technical data

Rated voltage	DC 3 V
Battery type	1×lithium CR 2032
carrier frequency	433.42 MHz (ASK)
Transmitting range in free field	typical 30 m
Dimensions W×HxD	73×40×19 mm
Ambient temperature	0 ... +55 °C
Relative humidity	max. 80 % (No moisture condensation)

6.2 Troubleshooting

Receiver does not respond, or only sometimes.

Cause 1: battery in the transmitter is empty.

Change the battery.

Cause 2: Radio range exceeded. Structural obstacles reduce the range.

Decrease distance to radio receiver.

6.3 Warranty

We reserve the right to make technical and formal changes to the product in the interest of technical progress.

Our products are under guarantee within the scope of the statutory provisions.

If you have a warranty claim, please contact the point of sale or ship the device postage free with a description of the fault to the appropriate regional representative.

Berker GmbH & Co. KG

Klagebach 38
58579 Schalksmühle/Germany
Telefon + 49 (0) 2355/905-0
Telefax + 49 (0) 2355/905-111
www.berker.de