

Residential and Commercial  
Metering solutions

# Specifications and technical guide

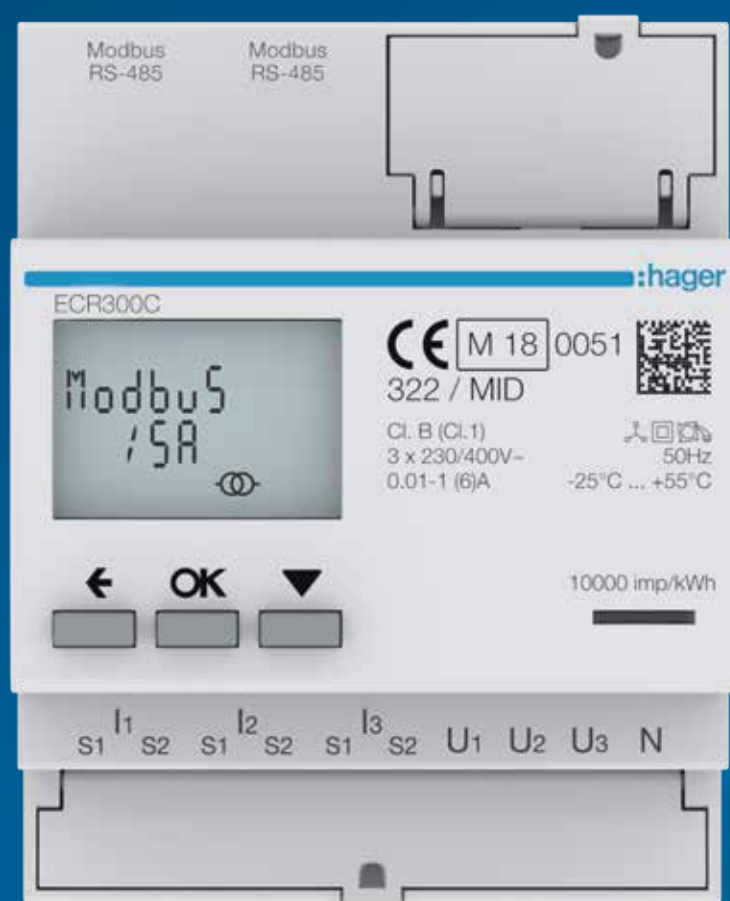

**:hager**

# Single phase direct 40 A range



## The main functions

- Single phase 40 A energy meter in direct reading,
- MID-certified as standards,
- Advanced metering, (sub-feeds and direct feeds).

## Basic functions

- Active energy,
- Active power,
- Voltage,
- Current,
- Power factor.

## Specifications

40 A meter intended for sub-metering for tertiary and residential applications. Available with a large communications panel (Pulse/Modbus), it enables the metering structure to be adapted to any new or existing installation. Available with a large communication panel (Pulse / Modbus), it enables the metering structure to be adapted to any new or existing installation while providing essential information for the analysis of the energy consumption and quality of the sub-feeds. Data is saved in the internal memory, enabling continuity of information to be guaranteed, even after a network failure.

- 01 Sealable enclosures supplied as standard providing safety,**
- 02 Pre-addressed product,**
- 03 Modbus,**
- 04 Available in MID or non-MID version.**

Reference	Voltage	Type of measurement	Rating	Communication	No. of 17.5 mm modules	Package
ECN140D	230 V AC	Direct	40 A	-	1	1 pcs
ECP140D	230 V AC	Direct	40 A (MID)	Pulse	1	1 pcs
ECR140D*	230 V AC	Direct	40 A (MID)	Modbus	1	1 pcs

\*Terminating resistor required if Modbus function is used. Refer to page 33.

## Function selection guide

Reference	ECN140D	ECP140D	ECR140D
Current	-	•	•
Voltage	-	•	•
Power factor	-	•	•
Frequency	-	•	•
Active power	-	•	•
Reactive power	-	-	via com
Apparent power	-	-	via com
Active energy	•	•	•
Reactive energy	-	-	via com
Partial resetting of consumption measurements	-	-	-
Energy import/export	-	•	•
Tariff control	-	-	•
Number of tariffs managed by: physical input/com	1/0	1/0	1/8
I/O function	-	•	-
Configurable I/O function	-	-	-
Programming of the max. demand threshold	-	-	-
Management of harmonics	-	-	-
Alarm function	-	-	-
Minimum / Maximum demand	-	-	-
Tariff control by physical input	-	-	-
Tariff control by communication system	-	-	•
Saved by internal memory	•	•	•

# Single phase direct 40 A range

## Dimensions

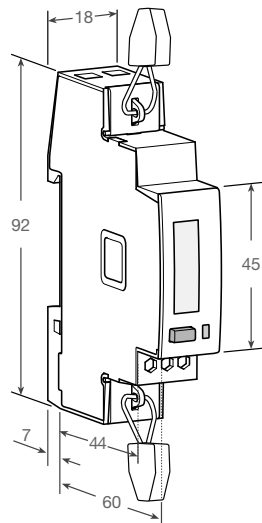

## Power wiring

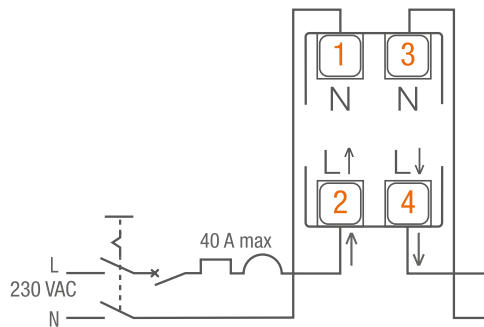
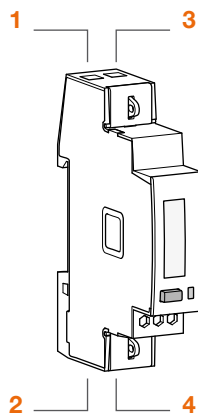

## Communication wiring

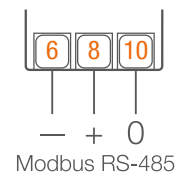
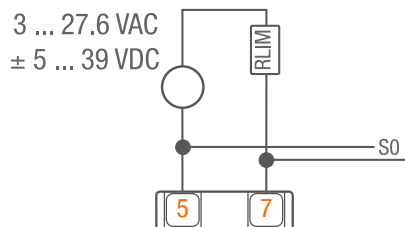

## Technical specifications

	Ref.	Single-phase direct 40 A		
		ECN140D	ECP140D	ECR140D
Nominal voltage		1 x 230 V		
Voltage range		184 V - 276 V		
Frequency		45...65Hz		
<b>General information</b>				
MID-certified product		-	MID, Class B	
Consumption of voltage circuits in VA/W		≤2/≤1		
Consumption of current circuits in VA/W		≤1		
Basic current I <sub>b</sub>		5 A		
Reference current I <sub>ref</sub>		5 A		
Transition current I <sub>tr</sub>		0.5 A		
Maximum current I <sub>max</sub>		40 A		
Minimum current I <sub>min</sub>		0.25 A		
Starting current		0.02 A		
Cable cross-section for the measurement circuit	- rigid - flexible	1.5 - 20 mm <sup>2</sup> 1 - 20 mm <sup>2</sup>		
Power terminals tightening torque		1 Nm		
Energy accuracy class		active Class 1 /reactive -		
Measurement accuracy in %		active/reactive 1%		
Type of display		LCD (without backlighting)		
Product material		Plastic		
Electrical protection device		Protected by a 40 A single-phase fuse (x1)		
<b>Input characteristics</b>				
Number of inputs		-		
Voltage		-		
OFF = T1		-		
ON = T2		-		
Cable cross-section		-		
Tightening torque		-		
<b>Pulse output specifications</b>				
Number of outputs		-	1	-
Max. pulse current 39 V DC		-	90 mA	-
V AC/V DC voltage		-	3-27.6/±5-39	-
Frequency of pulse output		-	1000 p/kWh	-
Pulse duration		-	100 ms	-
Cable cross-section:	- rigid - flexible	-	1.5 - 2.5mm <sup>2</sup> 1 - 2.5mm <sup>2</sup>	-
Tightening torque		-	0.5 Nm	-
<b>Communication output specifications</b>				
Protocol		-	-	Modbus RTU
Type of connector		-	-	Screw terminals
Cable cross-section		-	-	0.8 - 2.5 mm <sup>2</sup>
Tightening torque		-	-	0.5 Nm
<b>Pulse indicator (front panel LED)</b>				
Pulse frequency		5000 p/kWh		
<b>EMC compatibility</b>				
Surge voltage test		6 kV		
Overvoltage test		4 kV		
<b>Environmental data</b>				
Operating T°		-25...+55 °C		
Storage T°		-25...+70 °C		
Humidity		≤ 95% to 20 °C		
Resistance to fire/heat		V0		
Resistance to water/dust, installed/not installed		IP40/IP20	IP51/IP20	
Mechanical environment		M1		
Electromechanical environment		E2		
Dimensions L x H x D		18 x 92 x 60		
Number of DIN modules		1		
Standards		EN 50470-3, CEI 62053-21/23, CEI 61557-12, DIN 43880, EN 60715		
		-	EN 50470-1	-
		-	IEC 62053-31	-

# Single phase direct 80 A range



## The main functions

- Single phase 80 A energy meter in direct reading,
- MID-certified as standard,
- Advanced metering, (sub-feeds and direct feeds).

## Basic functions

- Active/reactive energy
- Active/reactive/apparent power
- Voltage,
- Current,
- Power factor
- Partial resetting of consumption
- Tariff management.

## Specifications

80 A meter intended for sub-metering for tertiary applications.

Available with a large communication panel (pulse/Modbus), it enables the metering structure to be adapted to any new or existing installation while providing essential information for the analysis of the energy consumption and quality of the sub-feeds.

Data is saved in the internal memory, enabling continuity of information to be guaranteed, even after a network failure.

- 01 Sealable enclosures supplied as standard providing safety,
- 02 Pre-addressed product
- 03 Modbus
- 04 MID-certified.

Reference	Voltage	Type of measurement	Rating	Communication	No. of 17.5 mm modules	Package
ECP180D	230 V AC	Direct	80 A	Pulse	2	1 pcs
ECR180D*	230 V AC	Direct	80 A	Modbus	2	1 pcs

\*Terminating resistor required if Modbus function is used. Refer to page 33.

## Function selection guide

Reference	ECP180D	ECR180D
Current	•	•
Voltage	•	•
Power factor	•	•
Frequency	•	•
Active power	•	•
Reactive power	•	•
Apparent power	•	•
Active energy	•	•
Reactive energy	•	•
Partial resetting of consumption measurements	•	•
Energy import/export	•	•
Tariff control	•	•
Number of tariffs managed by: physical input/com	2/0	2/8
I/O function	•	-
Configurable I/O function	•	-
Programming of the max. demand threshold	-	-
Management of harmonics	-	-
Alarm function	-	-
Minimum / Maximum demand	-	-
Tariff control by physical input	•	•
Tariff control by communication system	-	•
Saved by internal memory	•	•

# Single phase direct 80 A range

## Dimensions

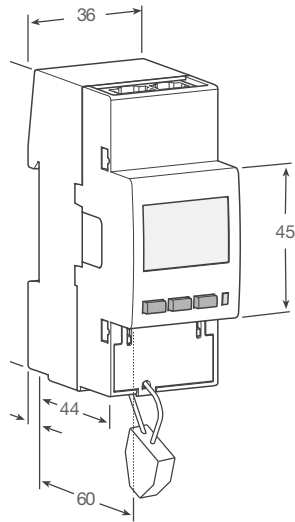

## Power wiring

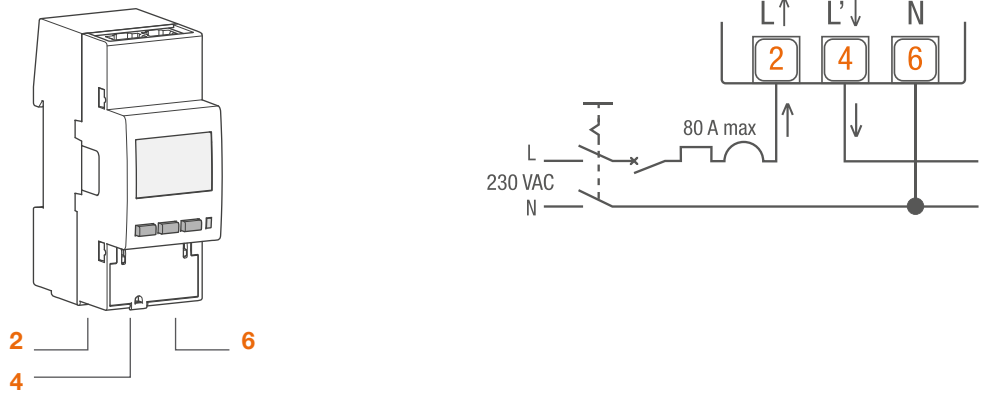

## Communication wiring

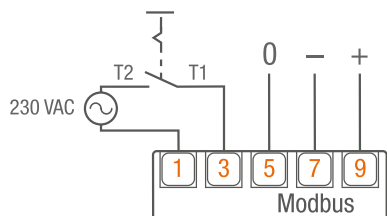
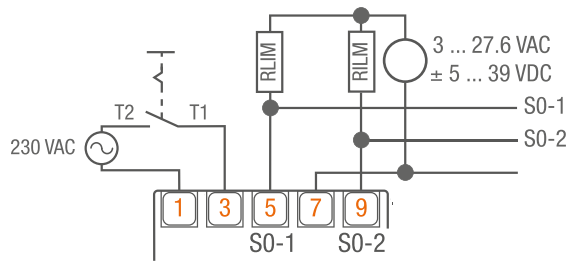



## Technical specifications

	Ref.	Single-phase direct 80 A	
		ECP180D	ECR180D
Nominal voltage		1 x 230 V	
Voltage range		92 V - 276 V	
Frequency		45...65 Hz	
<b>General information</b>			
MID-certified product		MID, Class B	
Consumption of voltage circuits in VA/W		≤2/≤1	
Consumption of current circuits in VA/W		≤1	
Basic current I <sub>b</sub>		5 A	
Reference current I <sub>ref</sub>		5 A	
Transition current I <sub>tr</sub>		0.5 A	
Maximum current I <sub>max</sub>		80 A	
Minimum current I <sub>min</sub>		0.25 A	
Starting current		0.015 A	
Cable cross-section for the measurement circuit	- rigid - flexible	2.5 - 33 mm <sup>2</sup> 2.5 - 33 mm <sup>2</sup>	
Power terminals tightening torque		2 Nm	
Energy accuracy class		active Class 1/reactive Class 2	
Measurement accuracy in %		active 1%/reactive 2%	
Type of display		LCD (backlighting)	
Product material		Plastic	
Electrical protection device		Protected by a 80 A single-phase fuse (x1)	
<b>Input characteristics</b>			
Number of inputs		1	
Voltage		230 V AC	
OFF = T1		0 V	
ON = T2		230 V AC	
Cable cross-section		1 - 4 mm <sup>2</sup> (flexible and rigid)	
Tightening torque		1 Nm	
<b>Pulse output specifications</b>			
Number of outputs		2	-
Max. pulse current 39 V DC		90 mA	-
V AC/V DC voltage		3-27.6/±5-39	-
Frequency of pulse output		1-1000 p/kWh	-
Pulse duration		30-100 ms	-
Cable cross-section:	- rigid - flexible	0.8 - 2.5 mm <sup>2</sup> 0.8 - 2.5 mm <sup>2</sup>	-
Tightening torque		0.5 Nm	-
<b>Communication output specifications</b>			
Protocol		-	Modbus RTU
Type of connector		-	Screw terminals
Cable cross-section		-	0.8 - 2.5 mm <sup>2</sup>
Tightening torque		-	0.5 Nm
<b>Pulse indicator (front panel LED)</b>			
Pulse frequency		1000 p/kWh	
<b>EMC compatibility</b>			
Surge voltage test		6 kV	
Overvoltage test		4 kV	
<b>Environmental data</b>			
Operating T°		-25...+55 °C	
Storage T°		-25...+70 °C	
Humidity		≤ 95% to 20 °C	
Resistance to fire/heat		V0	
Resistance to water/dust, installed/not installed		IP51/IP20	
Mechanical environment		M1	
Electromechanical environment		E2	
Dimensions L x H x D		36 x 92 x 60	
Number of DIN modules		2	
Standards		EN 50470-1/3, CEI 62053-21/23, CEI 61557-12, DIN 43880, EN 60715	
		EI 62053-31	-

# Single phase direct 3 x 80 A range



## The main functions

- 1 energy meter for 3 single phase feeds of 80 A in direct reading,
- Advanced metering, (sub-feeds and direct feeds).

## Basic functions

- Active/reactive energy,
- Active/reactive/apparent power,
- Voltage,
- Current,
- Power factor,
- Partial resetting of consumption,
- Tariff management.

## Specifications

80 A meter intended for sub-metering for tertiary applications.

It is equipped with three 80 A inputs, each enabling the space within the panel to be optimised and information to be sent from three 80 A sub-feeds via 1 single Modbus or M-bus address.

Available with a large communication panel (pulse/Modbus), it enables the metering structure to be adapted to any new or existing installation while providing essential information for the analysis of the energy consumption and quality of the sub-feeds.

Data is saved in the internal memory, enabling continuity of information to be guaranteed, even after a network failure.

- 01 Sealable enclosures supplied as standard providing safety,
- 02 Pre-addressed product,
- 03 One single Modbus for 3 metering points,
- 04 120 Ohm resistor integrated in the Modbus version.

Reference	Voltage	Type of measurement	Rating	Communication	No. of 17.5 mm modules	Package
ECP180T	230 V AC	Direct	80 A (x3 measurement points)	Pulse	4	1 pcs
ECR180T	230 V AC	Direct		Modbus	4	1 pcs

\*Terminating resistor required if Modbus function is used. Refer to page 33.

## Function selection guide

Reference	ECP180T	ECR180T
Current	•	•
Voltage	•	•
Power factor	•	•
Frequency	•	•
Active power	•	•
Reactive power	•	•
Apparent power	•	•
Active energy	•	•
Reactive energy	-	-
Partial resetting of consumption measurements	•	•
Energy import/export	•	-
Tariff control	•	•
Number of tariffs managed by: physical input / com	2/0	2/4
I/O function	•	-
Configurable I/O function	-	-
Programming of the max. demand threshold	-	-
Management of harmonics	-	-
Alarm function	-	-
Minimum / Maximum demand	-	-
Tariff control by physical input	•	•
Tariff control by communication system	-	•
Saved by internal memory	•	•

# Single phase direct 3 x 80 A range

## Dimensions

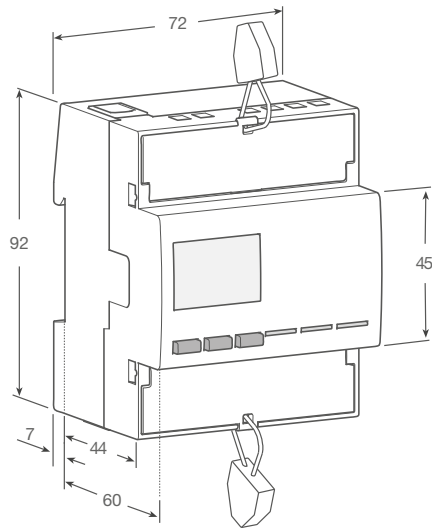

## Power wiring

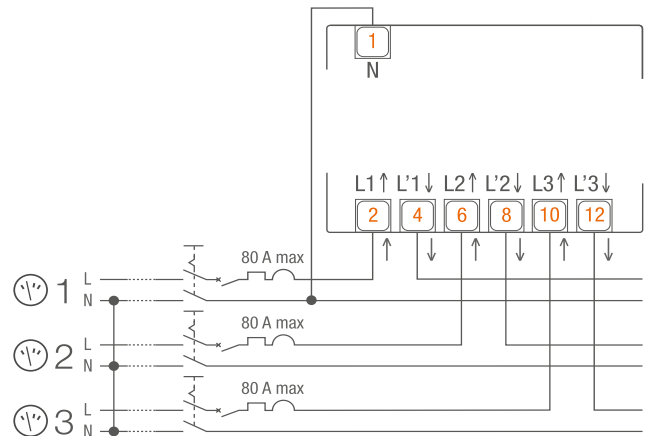
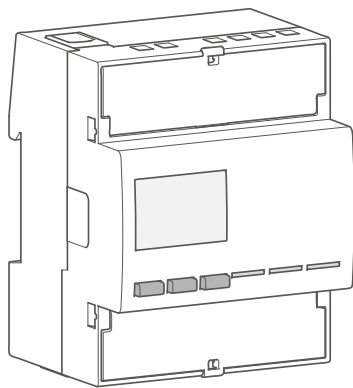

## Communication wiring

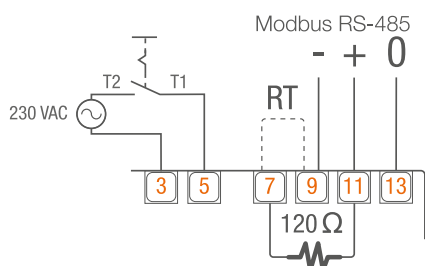
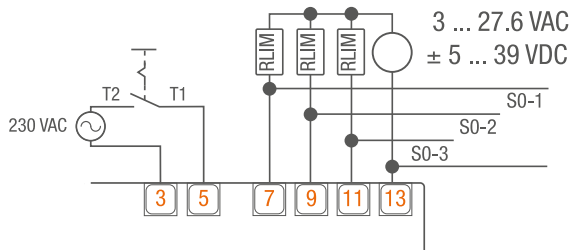

## Technical specifications

	Ref.	Single-phase direct 3 x 80 A	
		ECP180T	ECR180T
Nominal voltage		1 x 230 V	
Voltage range		184 V - 276 V	
Frequency		45...65 Hz	
<b>General information</b>			
MID-certified product		-	
Consumption of voltage circuits in VA/W		≤2/≤1	
Consumption of current circuits in VA/W		≤1	
Basic current I <sub>b</sub>		5 A	
Reference current I <sub>ref</sub>		5 A	
Transition current I <sub>tr</sub>		0.5 A	
Maximum current I <sub>max</sub>		80 A	
Minimum current I <sub>min</sub>		0.25 A	
Starting current		0.015 A	
Cable cross-section for the measurement circuit	- rigid - flexible	2.5 - 33 mm <sup>2</sup> 2.5 - 33 mm <sup>2</sup>	
Power terminals tightening torque		2 Nm	
Energy accuracy class		active Class 1/reactive Class 2	
Measurement accuracy in %		active 1%/reactive 2%	
Type of display		LCD (backlighting)	
Product material		Plastic	
Electrical protection device		Protected by a 80 A single-phase fuse (3 x counters)	
<b>Input characteristics</b>			
Number of inputs		1	
Voltage		230 V AC	
OFF = T1		0 V	
ON = T2		230 V AC	
Cable cross-section		0.8 - 2.5 mm <sup>2</sup> (flexible and rigid)	
Tightening torque		0.5 Nm	
<b>Pulse output specifications</b>			
Number of outputs		3	-
Max. pulse current 39 V DC		90 mA	-
V AC/V DC voltage		3-27.6/±5-39	-
Frequency of pulse output		1-1000 p/kWh	-
Pulse duration		30-100 ms	-
Cable cross-section:	- rigid - flexible	0.8 - 2.5 mm <sup>2</sup> 0.8 - 2.5 mm <sup>2</sup>	-
Tightening torque		0.5 Nm	-
<b>Communication output specifications</b>			
Protocol		-	Modbus RTU
Type of connector		-	Screw terminals
Cable cross-section		-	0.8 - 2.5 mm <sup>2</sup>
Tightening torque		-	0.5 Nm
<b>Pulse indicator (front panel LED)</b>			
Pulse frequency		1000 p/kWh	
<b>EMC compatibility</b>			
Surge voltage test		6 kV	
Overvoltage test		4 kV	
<b>Environmental data</b>			
Operating T°		-25...+55 °C	
Storage T°		-25...+70 °C	
Humidity		≤ 95% to 20 °C	
Resistance to fire/heat		V0	
Resistance to water/dust, installed/not installed		IP51/IP20	
Mechanical environment		M1	
Electromechanical environment		E2	
Dimensions L x H x D		72 x 92 x 60	
Number of DIN modules		4	
Standards		EN 50470-1/3, CEI 62053-21/23, CEI 61557-12, DIN 43880, EN 60715	
		EI 62053-31	-

# Three phase direct 80 A range



## The main functions

- Three phase 80 A energy meter in direct reading,
- MID-certified as standard,
- Advanced metering (direct feeds).

## Basic functions

- Active/reactive energy,
- Active/reactive/apparent power,
- Voltage,
- Current,
- Power factor,
- Partial resetting of consumption,
- Tariff management.

## Specifications

80 A meter intended for sub-metering for tertiary applications.

Available with a large communication panel (pulse/Modbus), it enables the metering structure to be adapted to any new or existing installation while providing essential information for the analysis of the energy consumption and quality of the sub-feeds.

Data is saved in the internal memory, enabling continuity of information to be guaranteed, even after a network failure.

- 01 Sealable enclosures supplied as standard providing safety,
- 02 Pre-addressed product,
- 03 Modbus,
- 04 120 Ohm resistor integrated in the Modbus version.

Reference	Voltage	Type of measurement	Rating	Communication	No. of 17.5 mm modules	Package
ECP380D	400 V AC	Direct	80 A	Pulse	4	1 pcs
ECR380D	400 V AC	Direct	80 A	Modbus	4	1 pcs

## Function selection guide

Reference	ECP380D	ECR380D
Current	•	•
Voltage	•	•
Power factor	•	•
Frequency	•	•
Active power	•	•
Reactive power	•	•
Apparent power	•	•
Active energy	•	•
Reactive energy	•	•
Partial resetting of consumption measurements	•	•
Energy import/export	•	•
Tariff control	•	•
Number of tariffs managed by: physical input / com	2/0	2/8
I/O function	•	-
Configurable I/O function	•	-
Programming of the max. demand threshold	-	-
Management of harmonics	-	-
Alarm function	-	-
Minimum / Maximum demand	-	-
Tariff control by physical input	•	•
Tariff control by communication system	-	•
Saved by internal memory	•	•

## Three phase direct 80 A range

### Dimensions

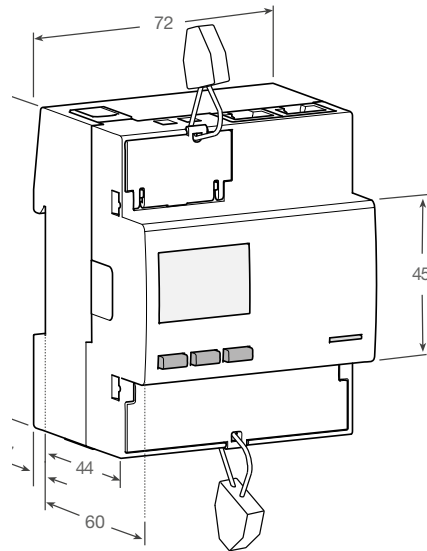

### Power wiring

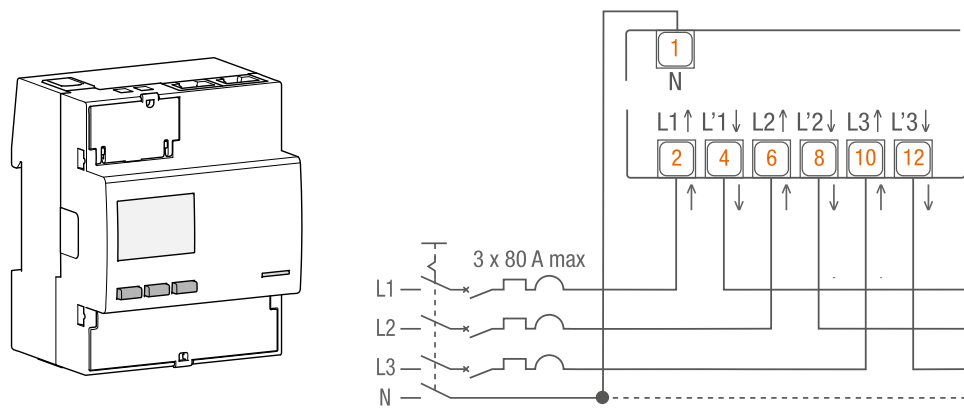

### Communication wiring

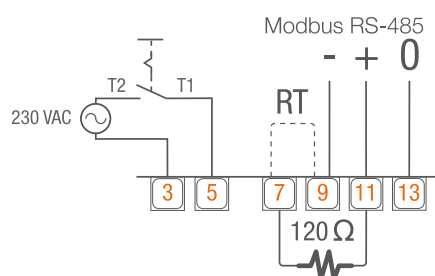
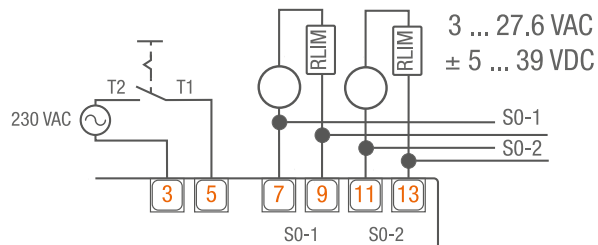



## Technical specifications

	Three-phase direct 80 A	
	Ref. ECP380D	ECR380D
Nominal voltage	1 x 400 V	
Voltage range	160 V - 480 V	
Frequency	45...65 Hz	
<b>General information</b>		
MID-certified product	MID, Class B	
Consumption of voltage circuits in VA/W	≤2/≤0.6	
Consumption of current circuits in VA/W	≤0.7	
Basic current I <sub>b</sub>	5 A	
Reference current I <sub>ref</sub>	5 A	
Transition current I <sub>tr</sub>	0.5 A	
Maximum current I <sub>max</sub>	80 A	
Minimum current I <sub>min</sub>	0.25 A	
Starting current	0.015 A	
Cable cross-section for the measurement circuit	- rigid - flexible	2.5 - 33 mm <sup>2</sup> 2.5 - 33 mm <sup>2</sup>
Power terminals tightening torque	2 Nm	
Energy accuracy class	active Class 1/reactive Class 2	
Measurement accuracy in %	active 1%/reactive 2%	
Type of display	LCD (backlighting)	
Product material	Plastic	
Electrical protection device	Protected by a 80 A three-phase fuse (x 1)	
<b>Input characteristics</b>		
Number of inputs	1	
Voltage	230 V AC	
OFF = T1	0 V	
ON = T2	230 V AC	
Cable cross-section:	0.8 - 2.5 mm <sup>2</sup> (rigid and flexible)	
Tightening torque	0.5 Nm	
<b>Pulse output specifications</b>		
Number of outputs	2	-
Max. pulse current 39 V DC	90 mA	-
V AC/V DC voltage	3-27.6/±5-39	-
Frequency of pulse output	1-200 p/kWh	-
Pulse duration	30-100 ms	-
Cable cross-section:	- rigid - flexible	0.8 - 2.5 mm <sup>2</sup> 0.8 - 2.5 mm <sup>2</sup>
Tightening torque	0.5 Nm	
<b>Communication output specifications</b>		
Protocol	-	Modbus RTU
Type of connector	-	Screw terminals
Cable cross-section	-	0.8 - 2.5 mm <sup>2</sup>
Tightening torque	-	0.5 Nm
<b>Pulse indicator (front panel LED)</b>		
Pulse frequency	1000 p/kWh	
<b>EMC compatibility</b>		
Surge voltage test	6 kV	
Overvoltage test	4 kV	
<b>Environmental data</b>		
Operating T°	-25...+55 °C	
Storage T°	-25...+70 °C	
Humidity	≤ 95% to 20 °C	
Resistance to fire/heat	V0	
Resistance to water/dust, installed/not installed	IP51/IP20	
Mechanical environment	M1	
Electromechanical environment	E2	
Dimensions L x H x D	72 x 92 x 60	
Number of DIN modules	4	
Standards	EN 50470-1/3, CEI 62053-21/23, CEI 61557-12, DIN 43880, EN 60715	
	IEC 62053-31	-

# Three phase direct 125 A range



## The main functions

- Three phase 125 A energy meter in direct reading,
- MID-certified as standard, Advanced metering (direct feeds).

## Basic functions

- Active/reactive energy,
- Active/reactive/apparent power,
- Voltage,
- Current,
- Power factor,
- Partial resetting of consumption,
- Tariff management.

## Specifications

125 A meter intended for sub-metering for tertiary applications.

Available with a large communication panel (pulse/Modbus), it enables the metering structure to be adapted to any new or existing installation while providing essential information for the analysis of the energy consumption and quality of the sub-feeds.

Data is saved in the internal memory, enabling continuity of information to be guaranteed, even after a network failure.

- 01 Sealable enclosures supplied as standard providing safety,
- 02 Pre-addressed product,
- 03 Modbus,
- 04 120 Ohm resistor integrated in the Modbus version.

Reference	Voltage	Type of measurement	Rating	Communication	No. of 17.5 mm modules	Package
ECP310D	400 V AC	Direct	125 A	Pulse	6	1 pcs
ECR310D	400 V AC	Direct	125 A	Modbus	6	1 pcs

## Function selection guide

Reference	ECP310D	ECR310D
Current	•	•
Voltage	•	•
Power factor	•	•
Frequency	•	•
Active power	•	•
Reactive power	•	•
Apparent power	•	•
Active energy	•	•
Reactive energy	•	•
Partial resetting of consumption measurements	•	•
Energy import/export	•	•
Tariff control	•	•
Number of tariffs managed by: physical input/com	2/0	2/8
I/O function	•	-
Configurable I/O function	•	-
Programming of the max. demand threshold	-	-
Management of harmonics	-	-
Alarm function	-	-
Minimum / Maximum demand	-	-
Tariff control by physical input	•	•
Tariff control by communication system	-	•
Saved by internal memory	•	•

## Three phase direct 125 A range

### Dimensions

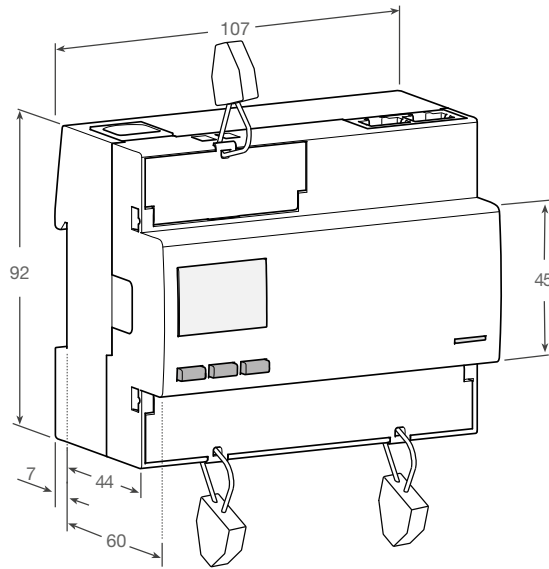

### Power wiring

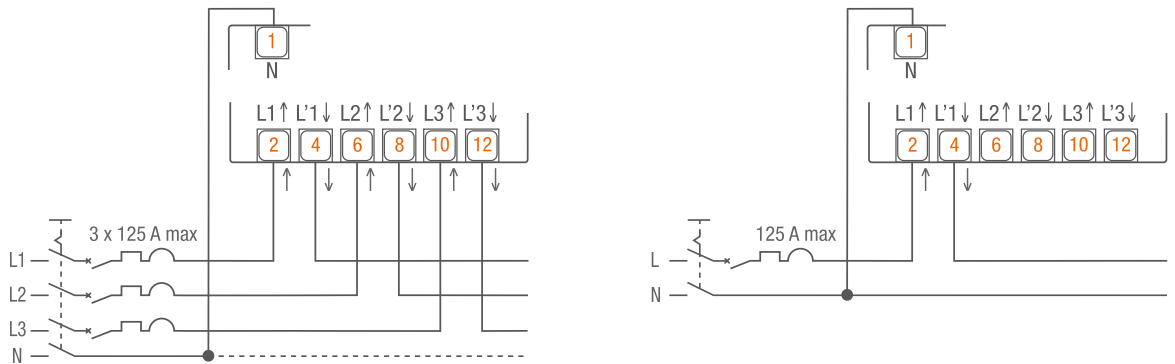

### Communication wiring

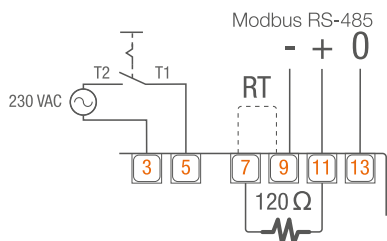
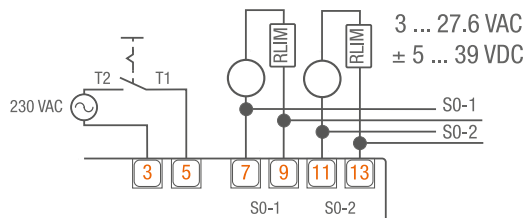

## Technical specifications

	Three-phase direct 125 A	
	Ref. ECP310D	ECR310D
Nominal voltage	1 x 400 V	
Voltage range	160 V - 480 V	
Frequency	45...65 Hz	
<b>General information</b>		
MID-certified product	MID, Class B	
Consumption of voltage circuits in VA/W	≤2/≤0.6	
Consumption of current circuits in VA/W	≤0.7	
Basic current I <sub>b</sub>	5 A	
Reference current I <sub>ref</sub>	5 A	
Transition current I <sub>tr</sub>	0.5 A	
Maximum current I <sub>max</sub>	125 A	
Minimum current I <sub>min</sub>	0.25 A	
Starting current	0.02 A	
Cable cross-section for the measurement circuit	- rigid - flexible	2.5 - 50 mm <sup>2</sup> 2.5 - 50 mm <sup>2</sup>
Power terminals tightening torque	5 Nm	
Energy accuracy class	active Class 1 / reactive Class 2	
Measurement accuracy in %	active 1% / reactive 2%	
Type of display	LCD (backlighting)	
Product material	Plastic	
Electrical protection device	Protected by a 125 A three-phase fuse (x 1)	
<b>Input characteristics</b>		
Number of inputs	1	
Voltage	230 V AC	
OFF = T1	0 V	
ON = T2	230 V AC	
Cable cross-section:	0.8 - 2.5 mm <sup>2</sup> (rigid and flexible)	
Tightening torque	1 Nm	
<b>Pulse output specifications</b>		
Number of outputs	2	-
Max. pulse current 39 V DC	90 mA	-
V AC/V DC voltage	3-27.6/±5-39	-
Frequency of pulse output	1-200 p/kWh	-
Pulse duration	30-100 ms	-
Cable cross-section:	- rigid - flexible	0.8 - 2.5 mm <sup>2</sup> 0.8 - 2.5 mm <sup>2</sup>
Tightening torque	0.5 Nm	
<b>Communication output specifications</b>		
Protocol	-	Modbus RTU
Type of connector	-	Screw terminals
Cable cross-section	-	0.8 - 2.5 mm <sup>2</sup>
Tightening torque	-	0.5 Nm
<b>Pulse indicator (front panel LED)</b>		
Pulse frequency	1000 p/kWh	
<b>EMC compatibility</b>		
Surge voltage test	6 kV	
Overvoltage test	4 kV	
<b>Environmental data</b>		
Operating T°	-25...+55 °C	
Storage T°	-25...+70 °C	
Humidity	≤ 95% to 20 °C	
Resistance to fire/heat	V0	
Resistance to water/dust, installed/not installed	IP51/IP20	
Mechanical environment	M1	
Electromechanical environment	E2	
Dimensions L x H x D	90 x 92 x 60	
Number of DIN modules	6	
Standards	EN 50470-1/3, CEI 62053-21/23, CEI 61557-12, DIN 43880, EN 60715	
	EI 62053-31	-

# Three phase indirect range



- 01 Sealable enclosures supplied as standard providing safety,
- 02 Pre-addressed product,
- 03 Modbus,
- 04 120 Ohm resistor integrated in the Modbus version.

## The main functions

- Three phase indirect energy meter in direct reading,
- MID-certified as standard,
- Advanced metering, (indirect feeds via 1/5A CTs).

## Basic functions

- Active/reactive energy,
- Active/reactive/apparent power,
- Voltage,
- Current,
- Power factor,
- Partial resetting of consumption,
- Tariff management.

## Specifications

Indirect meter intended for sub-metering for tertiary applications via current transformers of 1 or 5 A.

Available with a large communication panel (pulse/Modbus), it enables the metering structure to be adapted to any new or existing installation while providing essential information for the analysis of the energy consumption and quality of the sub-feeds.

Data is saved in the internal memory, enabling continuity of information to be guaranteed, even after a network failure.

Reference	Voltage	Type of measurement	Rating	Communication	No. of 17.5 mm modules	Package
ECP300C	400 V AC	Indirect	1/5 A via CT	Pulse	4	1 pcs
ECR300C	400 V AC	Indirect	1/5 A via CT	Modbus	4	1 pcs

## Function selection guide

Reference	ECP300C	ECR300C
Current	•	•
Voltage	•	•
Power factor	•	•
Frequency	•	•
Active power	•	•
Reactive power	•	•
Apparent power	•	•
Active energy	•	•
Reactive energy	•	•
Partial resetting of consumption measurements	•	•
Energy import/export	•	•
Tariff control	•	•
Number of tariffs managed by: physical input/com	2/0	2/8
I/O function	•	-
Configurable I/O function	•	-
Programming of the max. demand threshold	-	-
Management of harmonics	-	-
Alarm function	-	-
Minimum / Maximum demand	-	-
Tariff control by physical input	•	•
Tariff control by communication system	-	•
Saved by internal memory	•	•

## Three phase indirect range

### Dimensions

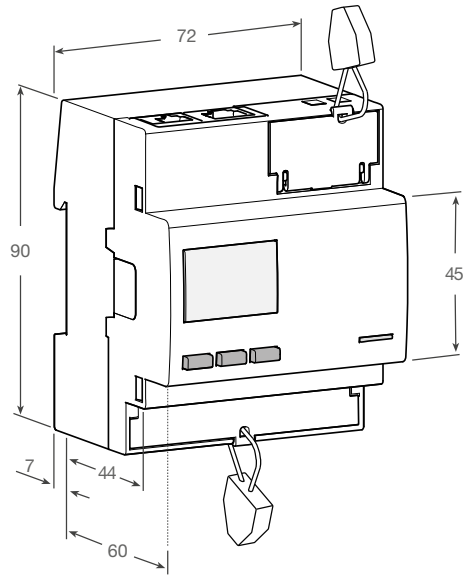

### Power wiring

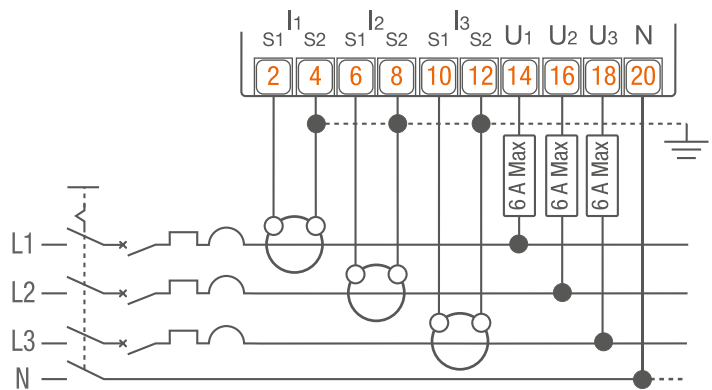
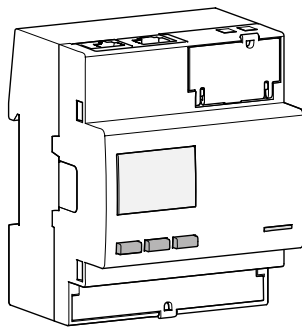

### Communication wiring

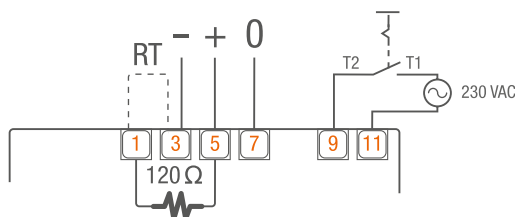
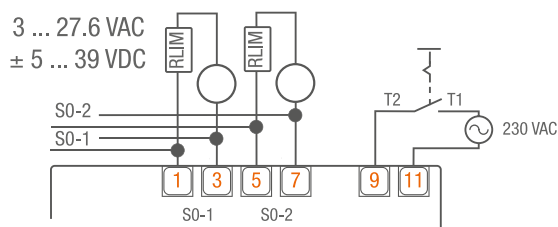



## Technical specifications

	Ref.	Three-phase indirect 1/5 A	
		ECP300C	ECR300C
Nominal voltage		1 x 400 V	
Voltage range		160 V - 480 V	
Frequency		45...65 Hz	
<b>General information</b>			
MID-certified product		MID	
Consumption of voltage circuits in VA/W		≤2/≤0.6	
Consumption of current circuits in VA/W		≤0.7	
Basic current I <sub>b</sub>		1(6) A	
Reference current I <sub>ref</sub>		1 A	
Transition current I <sub>tr</sub>		0.05 A	
Maximum current I <sub>max</sub>		6 A	
Minimum current I <sub>min</sub>		0.01 A	
Starting current		0.001 A	
Cable cross-section for the measurement circuit	- rigid - flexible	0.5 - 4 mm <sup>2</sup> 0.5 - 4 mm <sup>2</sup>	
Power terminals tightening torque		0.5 Nm	
Energy accuracy class		active Class 1/reactive Class 2	
Measurement accuracy in %		active 1%/reactive 2%	
Type of display		LCD (backlighting)	
Product material		Plastic	
Electrical protection device		Protected by a 6 A single-phase fuse (x 3)	
<b>Measurement input characteristics</b>			
Transformation ratio		Adjustable from 1 to 6000 (in 5 A, or 1200 in 1 A)	
<b>Input characteristics</b>			
Number of inputs		1	
Voltage		230 V AC	
OFF = T1		0 V	
ON = T2		230 V AC	
Cable cross-section:		1.5 - 4 mm <sup>2</sup> (rigid and flexible)	
Tightening torque		1 Nm	
<b>Pulse output specifications</b>			
Number of outputs		2	-
Max. pulse current 39 V DC		90 mA	-
V AC/V DC voltage		3-27.6/±5-39	-
Frequency of pulse output		1-1000 p/kWh	-
Pulse duration		30-100 ms	-
Cable cross-section:	- rigid - flexible	0.8 - 2.5 mm <sup>2</sup> 0.8 - 2.5 mm <sup>2</sup>	-
Tightening torque		0.5 Nm	-
<b>Communication output specifications</b>			
Protocol		-	Modbus RTU
Type of connector		-	Screw terminals
Cable cross-section		-	0.8 - 2.5 mm <sup>2</sup>
Tightening torque		-	0.5 Nm
<b>Pulse indicator (front panel LED)</b>			
Pulse frequency		1000 p/kWh (without taking into account the transformation ratio)	
<b>EMC compatibility</b>			
Surge voltage test		6 kV	
Overvoltage test		4 kV	
<b>Environmental data</b>			
Operating T°		-25...+55 °C	
Storage T°		-25...+70 °C	
Humidity		≤ 95% to 20 °C	
Resistance to fire/heat		V0	
Resistance to water/dust, installed/not installed		IP51 /IP20	
Mechanical environment		M1	
Electromechanical environment		E2	
Dimensions L x H x D		72 x 92 x 60	
Number of DIN modules		4	
Standards		EN 50470-1/3, CEI 62053-21/23, CEI 61557-12, DIN 43880, EN 60715	
		EI 62053-31	-

# Measurement unit range



## The main functions

A measurement unit enables analysis of the networks.

It records basic parameters, such as current, voltage, Cos Phi, power and energy, as well as harmonic disturbances and the reaction to different parameters.

Installed at the head of the installation and in sensitive networks, the measurement unit provides essential information to check the operating derivatives of a building.

**01 Separate communication and memory expansion module can be added subsequently (on SM102E and SM103E),**

**02 Configuration of the minimum and maximum thresholds,**

**03 Tariff level controlled via communication.**

Reference	Voltage	Type of measurement	Rating	Communication	No. of 17.5 mm modules	Package
SM101C	400 V AC	Indirect	1/5 A	Modbus	4	1 pcs
SM102E	400 V AC	Indirect	1/5 A	Pulse (ref. SM200) Modbus RTU (ref. SM210)	Built-in	1 pcs
SM103E	400 V AC	Indirect	1/5 A	Pulse (ref. SM201) Modbus RTU (ref. SM210 or SM213) Ethernet (ref. SM213 or SM214)	Built-in	1 pcs

## Function selection guide

Reference	SM101C	SM102E	SM103E
Current	•	•	•
Voltage	•	•	•
Power factor	•	•	•
Frequency	•	•	•
Active power	•	•	•
Reactive power	•	•	•
Apparent power	•	•	•
Active energy	•	•	•
Reactive energy	•	•	•
Internal clock	•	•	•
Advanced internal clock function	•	•	•
Partial resetting of consumption measurements	-	-	-
Import/export of energy	•	•	•
Tariff control	•	•	•
I/O function	•	•	•
Configurable I/O function	•	•	•
Programming of the maximum demand threshold	•	•	•
Management of harmonics	-	•	•
Alarm function	•	•	•
Recording of measured values per day/week/month	-	-	-
Minimum/maximum demand	•	•	•
Tariff control by physical input	•	•	•
Tariff control by communication system	•	•	•
Tariff control by the clock	•	•	•
Saved by internal memory			

## Measurement unit range

### SM102E built-in measurement unit

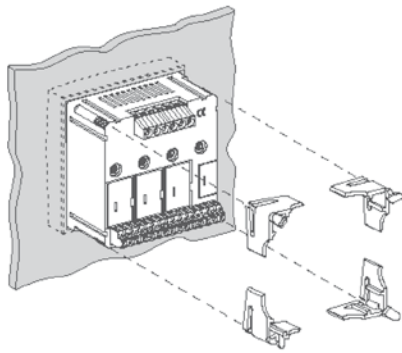
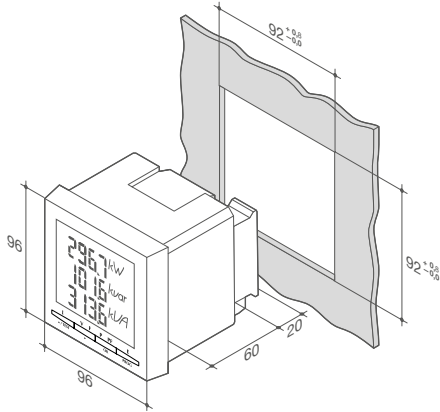

Unit locking system on the faceplate

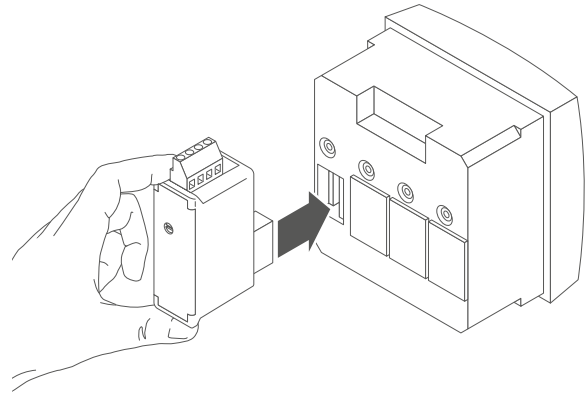

Insertion of communication modules

### SM101C measurement unit on DIN rail

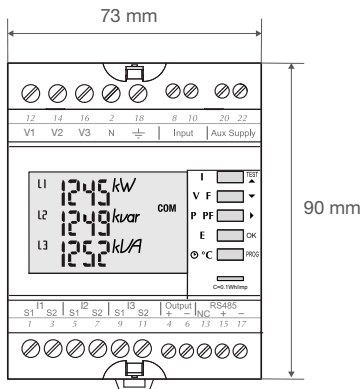

## Technical specifications

Ref.	Three-phase		
	SM101C	SM102E	SM103E
Nominal voltage	400 V		
Voltage range	50 V - 500 V between phase		
	28 V - 289 V between phase and neutral		
Frequency	45...65 Hz		
MID-certified product	-		
Consumption of voltage circuits in VA	≤5		
Consumption of current circuits in VA/W	≤0.6		
Transformation ratio of the CT	1 A/5 A, secondary		
Permissible CT measurement	5 A to 9999 A, primary		
Cross-section of rigid cables for the measurement circuit	2.5 mm <sup>2</sup>		
Power terminals tightening torque	0.6 Nm	0.4 Nm	
Frequency	45–65 Hz		
Accuracy class of active power and reactive power	Cl.0.5S/Cl.2		
Measurement accuracy in %	active 0.5%/reactive 2%		
Type of display (type of screen)	LCD		
Product material	Plastic		
Operating temperature	-10...+55 °C	-10...+55 °C	
Storage temperature	-20...+70 °C	-20...+85 °C	
Resistance to water and dust, front face/casing	IP51/IP20	IP52/IP30	
Number of outputs	1	-	-
Max. pulse current at 39 V DC	27 mA	-	-
Voltage	20–30 V DC	-	-
Pulse duration	100–900 ms	-	-
Permissible cross-section of cables, rigid/flexible	2.5 mm <sup>2</sup>	-	-
Recommended tightening torque for communication terminals	0.6 Nm	-	-
Number of inputs	1	-	-
Voltage	230 V AC	-	-
OFF == T1	0 V	-	-
ON == T2	230 V	-	-
Minimum pulse duration	-	-	-
Permissible cross-section of cables, rigid/flexible	2.5 mm <sup>2</sup>	-	-
Recommended tightening torque	0.6 Nm	-	-
Protocol	Modbus RTU	Modbus RTU (ref. SM210)	Modbus RTU (ref. SM210 or SM213)
		-	Ethernet (ref. SM213 or SM214)
		Pulse (ref. SM200)	Pulse (ref. SM201)
Type of connector	Screw terminals		
Permissible cross-section of cables, rigid/flexible	2.5 mm <sup>2</sup>		
Recommended tightening torque	0.6 Nm	0.5 Nm	
Dimensions L x H x D	73 x 90 x 67	96 x 96 x 60	
Number of DIN modules	4	-	-
Standards	IEC 62053-22/23	IEC 62053-22/23	IEC 61000-4-2/4-3/4-4/4-5
	IEC 61326-1	IEC 61000-4-2/4-3/4-4/4-5	IEC 61000-4-6/4-8/6-4/4-11
	IEC 60068-2-1/2-2/2-30	IEC 61000-4-6/4-8/4-11	IEC 60068-2-1/2-2/2-30/2-52
	IEC 60068-2-52/2-6	IEC 60068-2-1/2-2/2-30	IEC 60068-2-6
	IEC 61010-1	IEC 60068-2-52/2-6	IEC 60947-1
	IEC 62053-31	IEC 60947-1	IEC 61010-1
		IEC 61010-1	

# Current transformer range

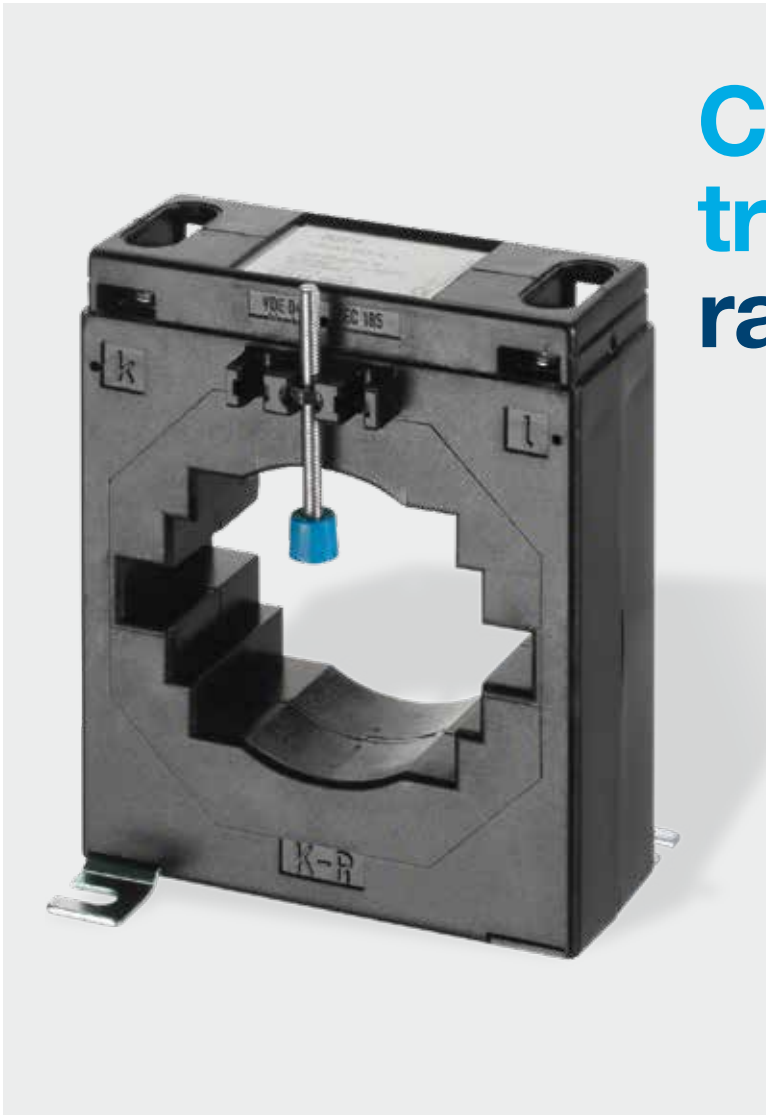

- 01 Current transformers equipped with twin current socket terminals,
- 02 Range dedicated to measuring the current on busbars and supply cables.

## References

### Current transformers (CT)

Ratio	Cat ref.
50/5	<b>SRA00505</b>
100/5	<b>SRA01005</b>
150/5	<b>SRA01505</b>
200/5	<b>SRA02005</b>
250/5	<b>SRA02505</b>
300/5	<b>SRI03005</b>
400/5	<b>SRC04005</b>
600/5	<b>SRC06005</b>
DIN rail mount for CTs	<b>SRZH01</b>



SRA00505



SRI03005



SRC06005

# Wiring

## 01 Significance of the shunt terminals for connection of current transformers

### Why shunt the current transformers?

When the secondary side of the current transformer is left open and, at the same moment, the primary side is supplied with power, the load impedance will approach infinity. In mechanical terms, this translates as rapid overheating and destruction of the current transformer due to extremely elevated voltage at the transformer terminals.

A damaged current transformer can become a source of electrocution and will no longer send information. It is therefore crucial to shunt its secondary side when no metering system is connected to it.

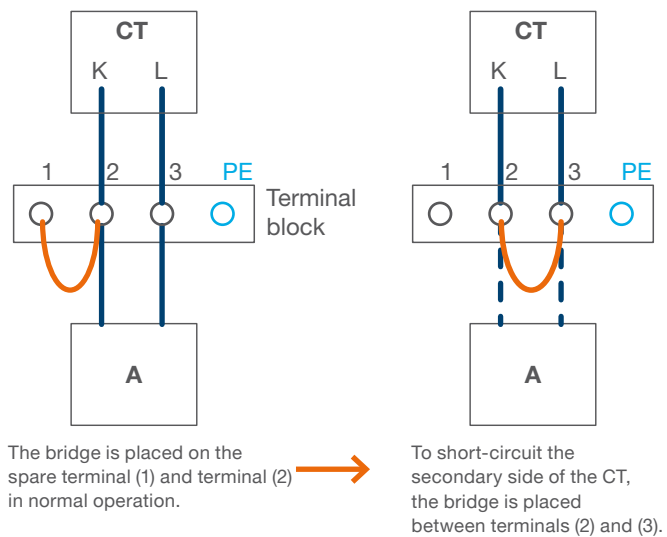



02

**Direction of current flow and connection between terminals**

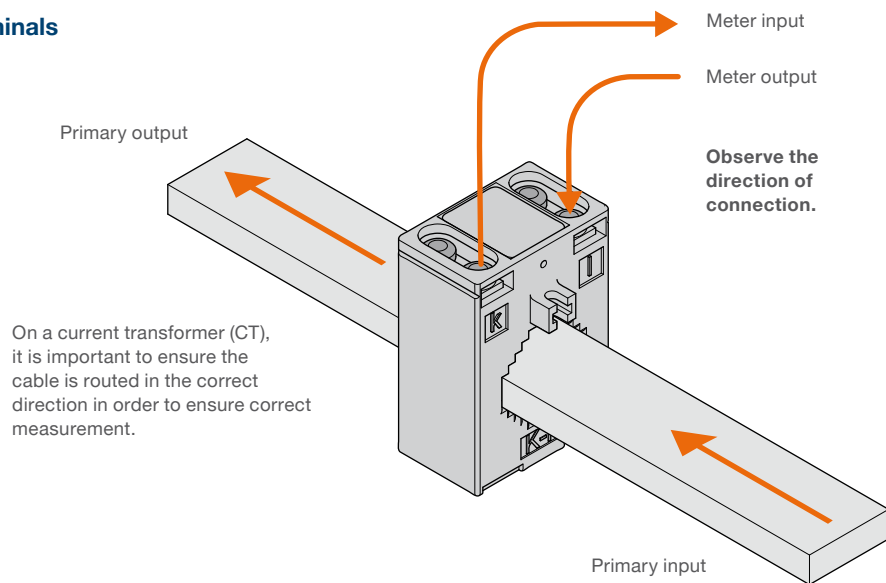

**Wiring accessories**

Resistor

Reference	Designation	Connector	Use
SMC120R	120 Ohm terminating resistor	pin	Modbus line termination



SMC120R



**Hager Electro Pty Ltd**  
Unit 17/2-8 South Street  
Rydalmere 2116 NSW

Phone: 1300 850 253  
Fax: 1300 424 372  
[customerservice@hagerelectro.com.au](mailto:customerservice@hagerelectro.com.au)  
[hagerelectro.com.au](http://hagerelectro.com.au)