

6VF00400.d

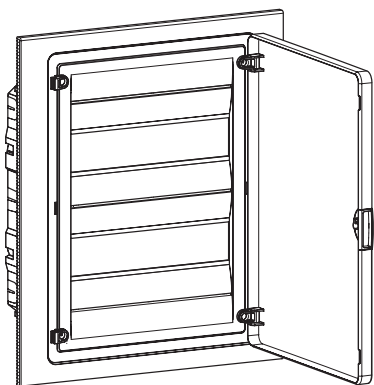

- (GB) **Mounting instructions**
- (FR) Notice d'instructions
- (DE) Montageanleitung
- (NL) Montage instructie
- (DK) Monteringsvejledning
- (FI) Asennusohje
- (NO) Montasjeanvisning
- (SE) Monterings instruktioner
- (IT) Istruzioni di montaggio
- (ES) Instrucciones de montaje
- (PT) Instruções de montagem
- (CZ) Montážní návod
- (BA) Uputstvo za montažu
- (UK) Інструкції з установки
- (HR) Upute za montažu
- (HU) Szerelési útmutató
- (LT) Montavimo instrukcija
- (LV) Montāžas instrukcija
- (PL) Instrukcja montażowa
- (RO) Instrucțiuni de montare
- (SK) Návod na montáž
- (RU) Указания по установке
- (BG) Инструкции за монтаж
- (GR) Οδηγίες χώνευσης
- (SI) Navodilo za montažo
- (EE) Paigaldusjuhised
- (IS) Leiðbeiningar
- (AR) دليل التركيب

golf

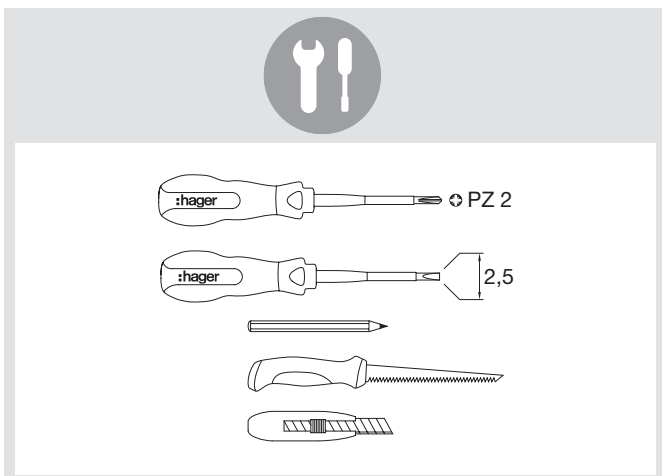
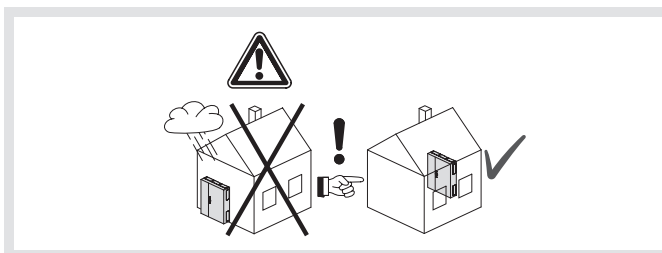

				Class 1*	Class 2*	Class 5*
C1	2x M4	1,7 Nm	12 mm	10-16 mm ²		
C2	M5	2,3 Nm		1,5-16 mm ²		
C3	M4	1,7 Nm		1,5-10 mm ²		

* IEC 60228

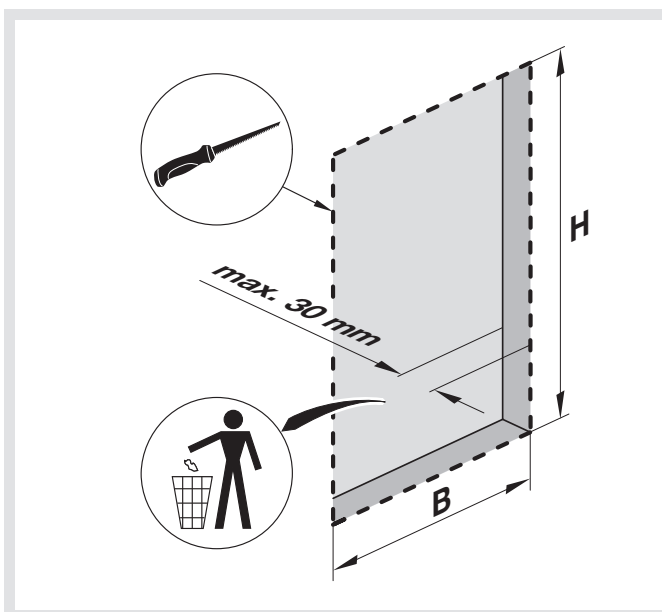

	H (mm)	B (mm)
VF104	189	170
VF108	189	242
VF112	257	318
VF212	382	318
VF312	507	318
VF412	652	318
VF118	257	426
VF218	382	426
VF318	507	426
VF418	652	426
VF122	257	498

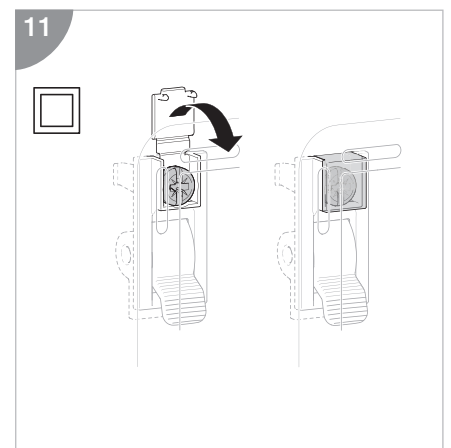
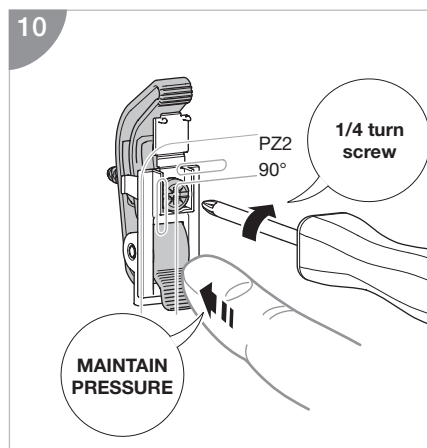
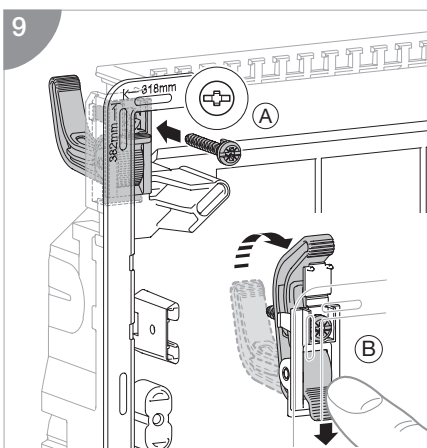
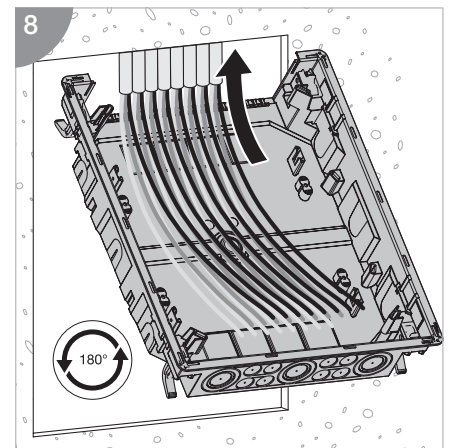
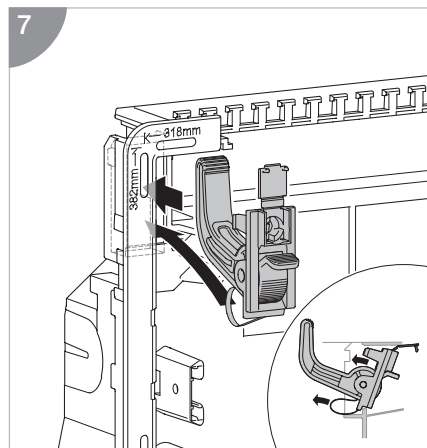
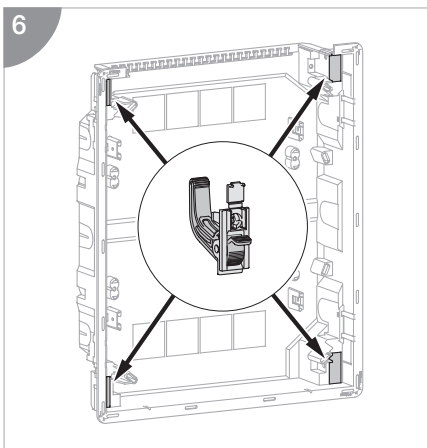
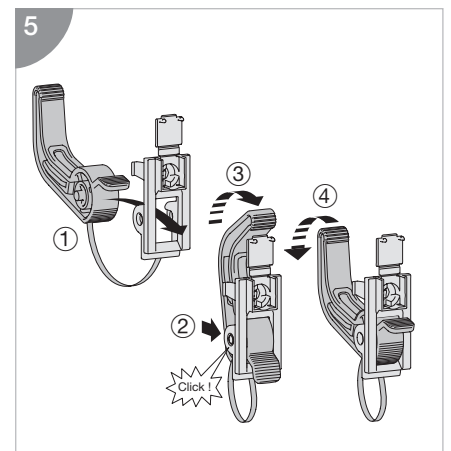
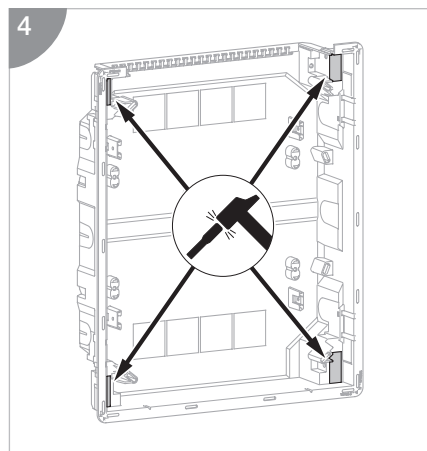
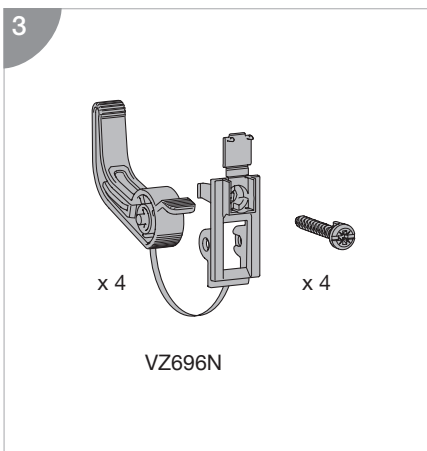
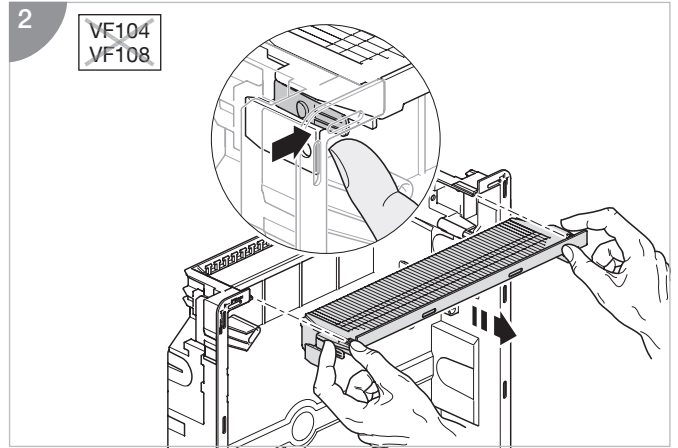
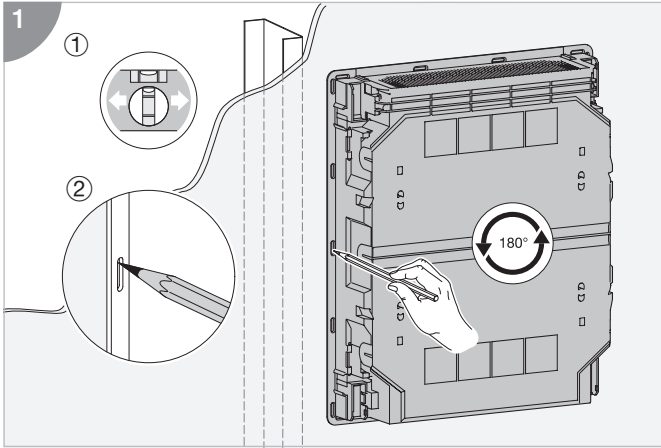

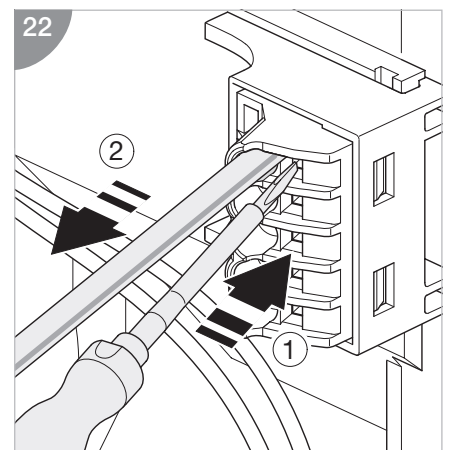
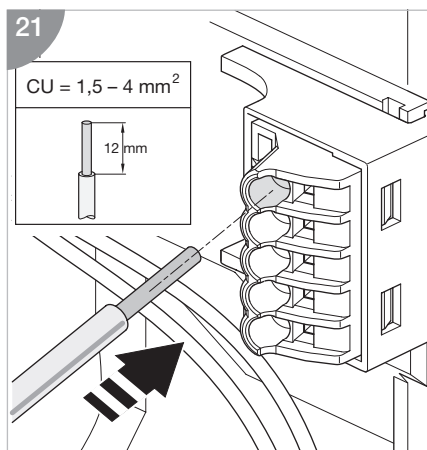
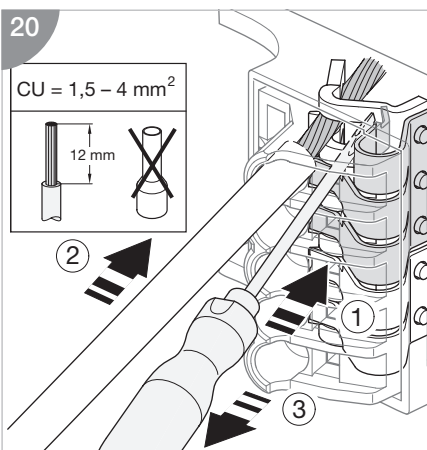
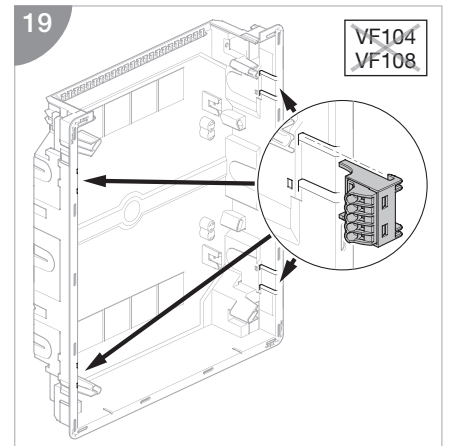
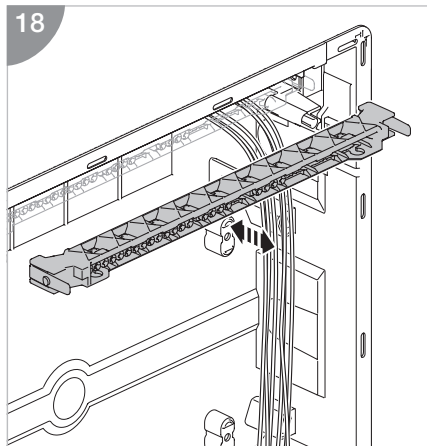
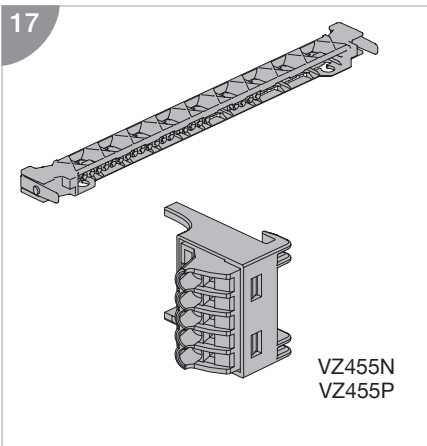
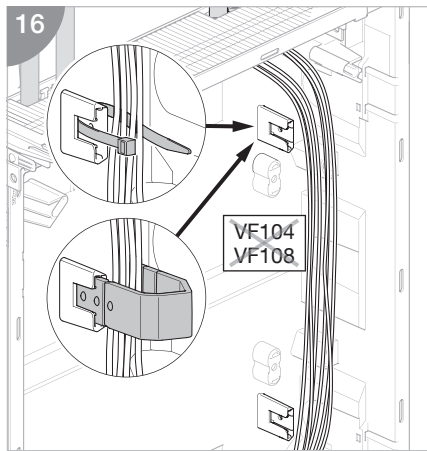
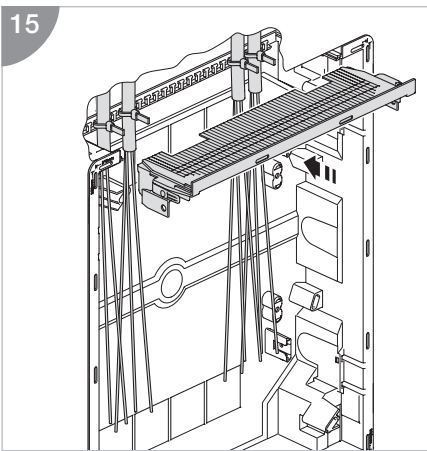
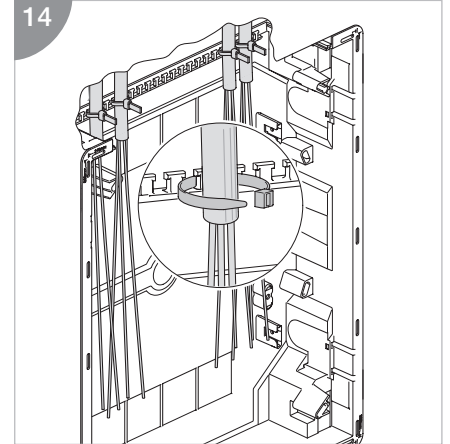
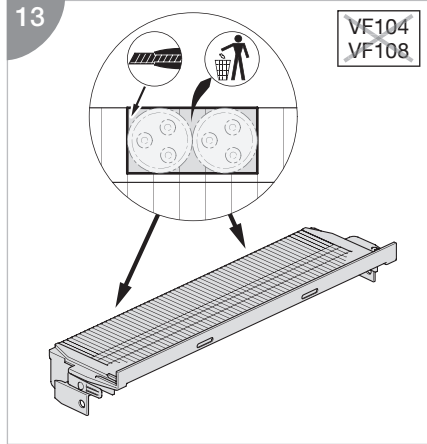
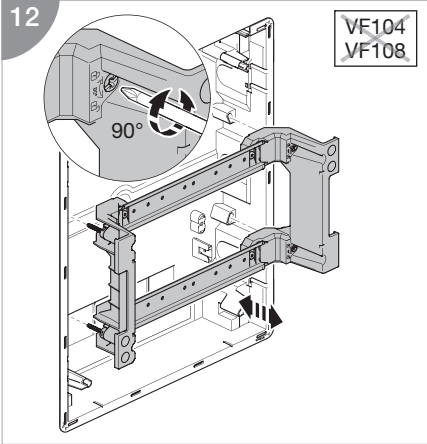

23

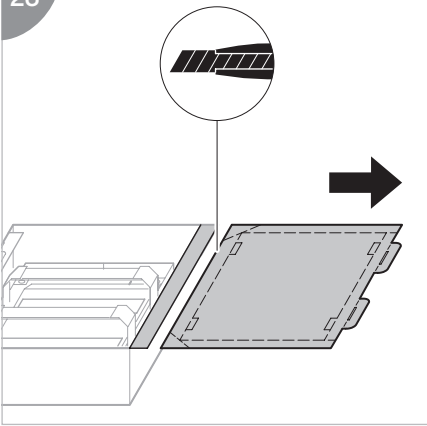

24

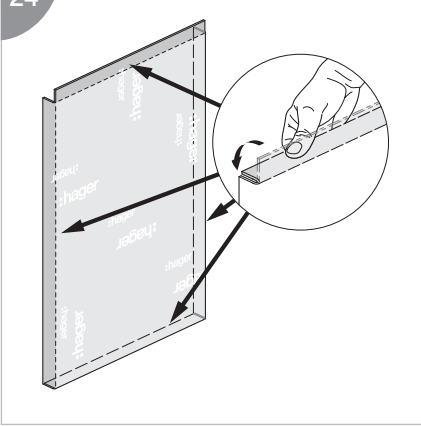

25

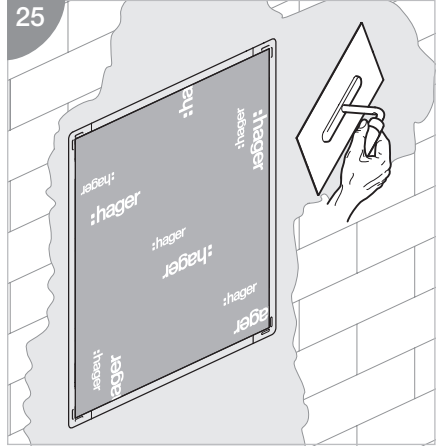

26

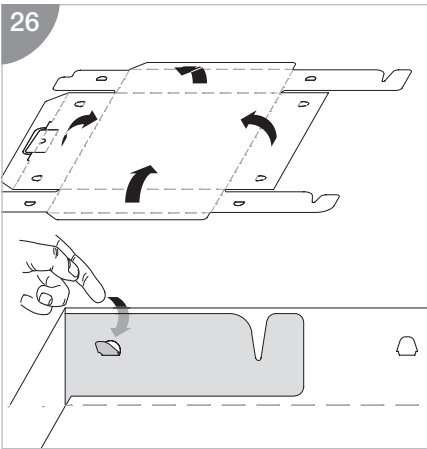

27

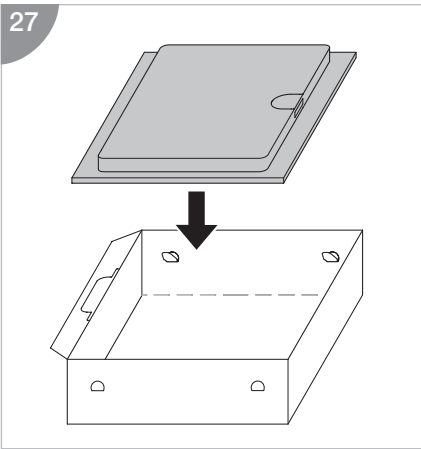

28

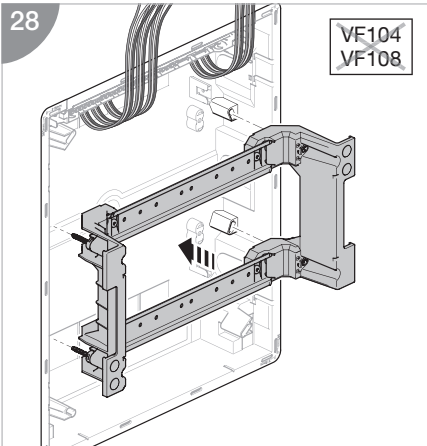

29

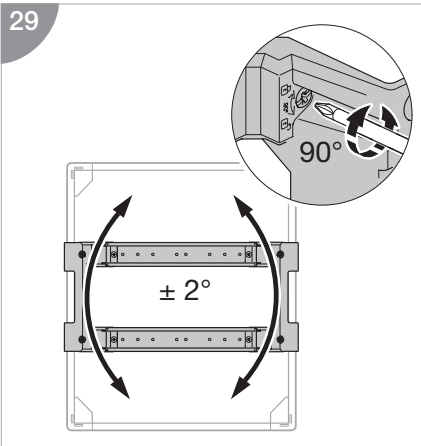

30

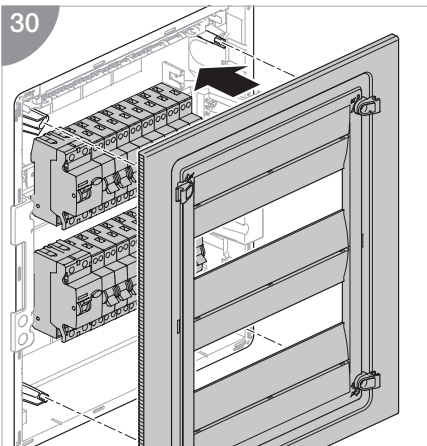

31

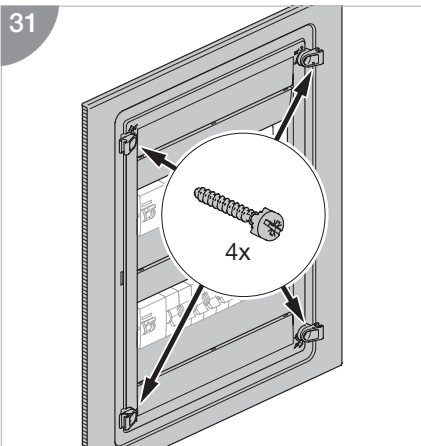

32

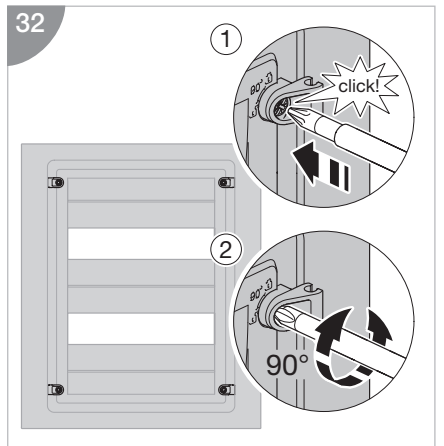

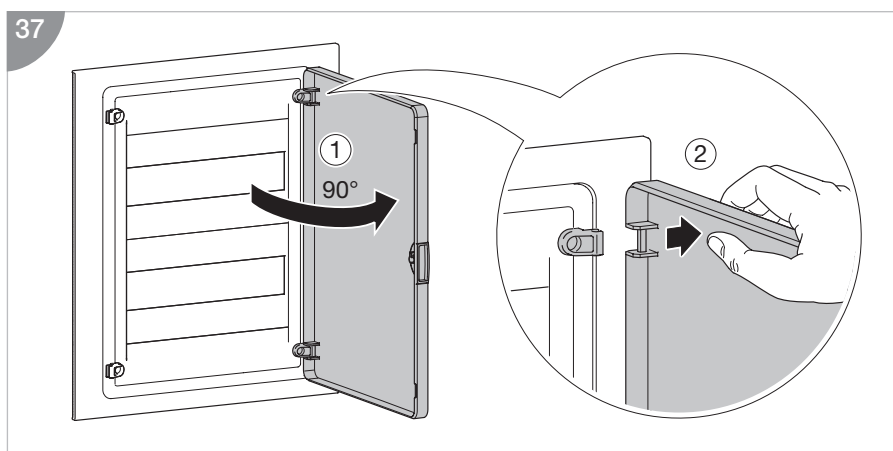
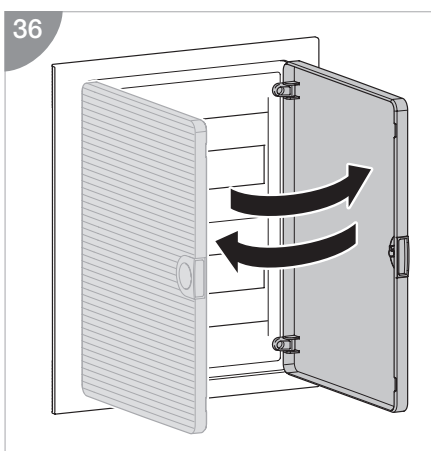
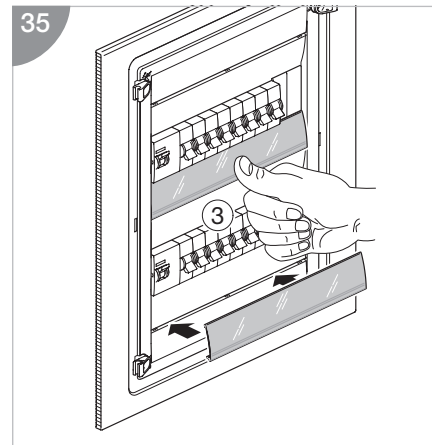
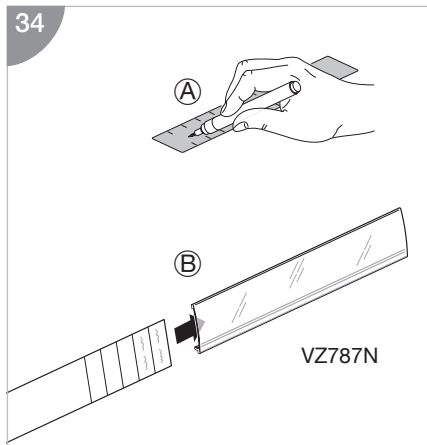
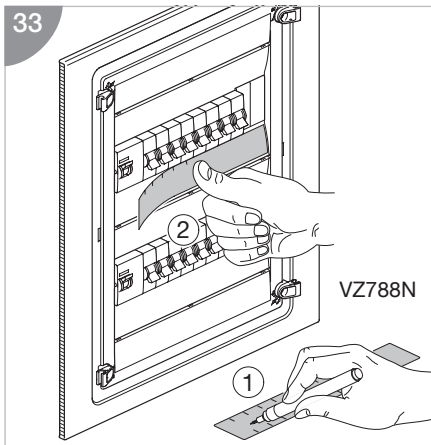

Attention!
It is critical that any enclosure is sized and selected to accommodate and dissipate heat rise generated from all installed devices. The table (right) provides maximum permissible heat dissipation for each golf enclosure size. Please ensure that you calculate internal heat generated from your installation and select the correct enclosure accordingly.

Reference	Admissible thermal dissipation loss for flush mounted distribution boards at temperature rise ΔT^*				
	10K W	15K W	20K W	25K W	30K W
VF104	2,5	4,1	5,9	7,7	9,7
VF108	2,8	4,6	6,5	8,6	10,8
VF112	4,4	7,2	10,4	13,7	17,2
VF212	5,7	9,5	13,5	17,9	22,4
VF312	7,1	11,7	16,8	22,1	27,8
VF412	8,7	14,4	20,5	27,1	34,0
VF118	5,8	9,6	13,8	16,2	22,8
VF218	7,6	12,6	17,9	23,7	29,7
VF318	9,2	15,3	21,9	28,9	36,2
VF418	11,2	18,5	26,5	35,0	43,9
VF122	6,8	11,2	16,0	21,1	26,5

*) ΔT is the temperature difference between the upper limiting temperature of the installed equipment and the ambient air temperature of the distribution board.

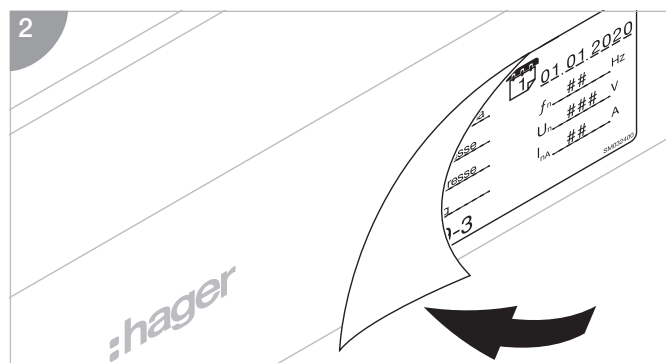
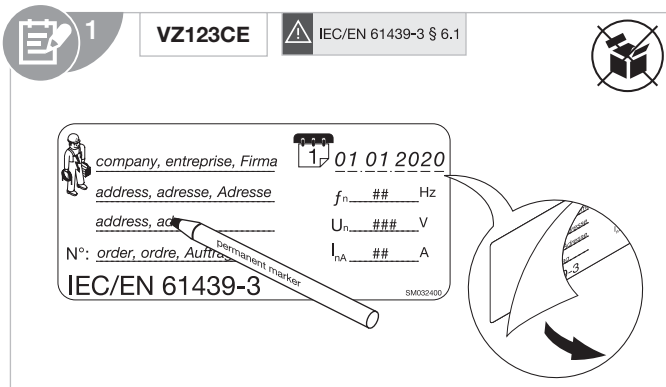

- ! EN The Assembly (DBO) designated markings must be completed as specified in IEC/EN 61439 - 3 clause 6.1.
- FR Le marquage de l'installation à basse-tension (DBO) doit être renseigné avec les spécifications techniques indiquées dans la norme IEC/EN 61439-3 paragraphe 6.1.
- DE Die Schaltgerätekombination (DBO) muss mit den Aufschriften nach IEC/EN 61439-3 Abschnitt 6.1 gekennzeichnet werden.
- NL De voor Assemblage (DBO) bestemde markeringen moeten worden ingevuld zoals gespecificeerd in IEC/EN 61439-3 paragraaf 6.1.
- DA DBO-mærkningerne (markeringsmærkerne) skal udfyldes som specificeret i IEC/EN 61439-3 punkt 6.1.
- FI Maallikkokäyttöön tarkoitettujen jakokeskusten merkinnät on täytettävä IEC/EN 61439-3:n lausekkeen 6.1 mukaisesti.
- NO Enhetens (fordelingskort) merking må være komplett som spesifisert i IEC/EN 61439-3 klausul 6.1.
- SV Kopplingsutrustningen måste märkas med etikett i enlighet med IEC / EN 61439-3 avsnitt 6.1.
- IT Le marcature designate per l'assemblaggio (DBO) devono essere integrate come specificato nella norma IEC/EN 61439-3 sezione 6.1.
- ES El conjunto de la apartamenta debe estar señalado/marcado de acuerdo con la norma IEC 61439-3 sección 6.1.
- PT As marcações designadas devem ser realizadas conforme especificado na IEC/EN 61439-3 cláusula 6.1 para o Conjunto (DBO).
- CS Označení určena pro montáž (DBO) musí být vyplněny podle specifikace normy IEC/EN 61439-3, článku 6.1.
- HR Oznake za sklapanje (DBO) moraju biti navedene prema preporukama iz IEC/EN 61439-3, klauzule 6.1.
- HU A berendezés (DBO) felirati megjelölésének összhangban kell lennie az IEC/EN 61439-3 szabvány 6.1 pontjában foglaltakkal.
- LT Montžas (DBO) apžimėjumiai jāatbilst IEC/NE 61439-3 6.1. punkta prasībām.
- LV Montāžas (DBO) marķējums jāiekļauj Standarta IEC/EN 61439-3 6.1. punktā norādītā informācija.
- PL Rozdzielnica musi być oznakowana zgodnie z IEC/EN 61439-3 rozdział 6.1.
- RO Marcajele destinate ansamblurilor (DBO) trebuie completate conform precizărilor din standardul IEC/EN 61439-3 punctul 6.1.
- RU Должна быть выполнена маркировка для сборки (Распределительные щиты, обслуживаемые лицами без специальной квалификации (DBO)) в соответствии с требованиями стандарта IEC/EN 61439-3, пункт 6.1.
- BG Обозначенията за монтаж (DBO) трябва да отговарят на изискванията, посочени в IEC/EN 61439-3, точка 6.1.
- EL Οι σημάνσεις συναρμολόγησης (DBO) πρέπει να συμμορφώνονται με τη ρήτρα 6.1 του προτύπου IEC/EN 61439-3.
- SL Oznake, določene za sestavo (DBO), morajo biti izpolnjene v skladu s klavzulo 6.1 standarda IEC/EN 61439-3.
- SK Označenia určené pre montáž (DBO) musia byť vyplnené podľa špecifikácie normy IEC/EN 61439-3, článku 6.1.
- EE Koosteale (DBO) lisatud märgised peavad vastama standardi IEC/EN 61439-3 punktile 6.1.
- IS Merkingar samsetningar (DBO) verða að vera útfylltar eins og tilgreint er í ákvæði 6.1 í IEC/EN 61439-3.