

Data Sheet

JF863BM - JF864BM 3 & 4 Pole MCCB Incomer Kits

6H5560F

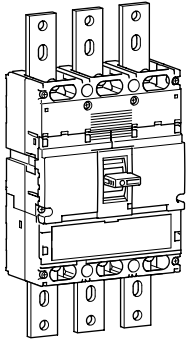

630A Incomer kits contain:

- 3 x Phase extension links
- 3 x spreader links
- 6 x Phase link Allen fixing bolts and washers (M10)
- 4 x Long fixing screws
- 1 x MCCB
- 3 x M8 120mm Lug
- Terminal covers
Ensure terminal shrouds are removed before fitting.

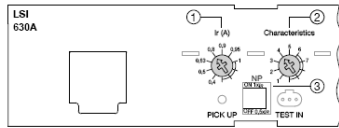
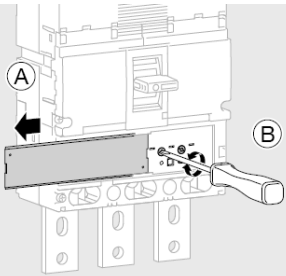
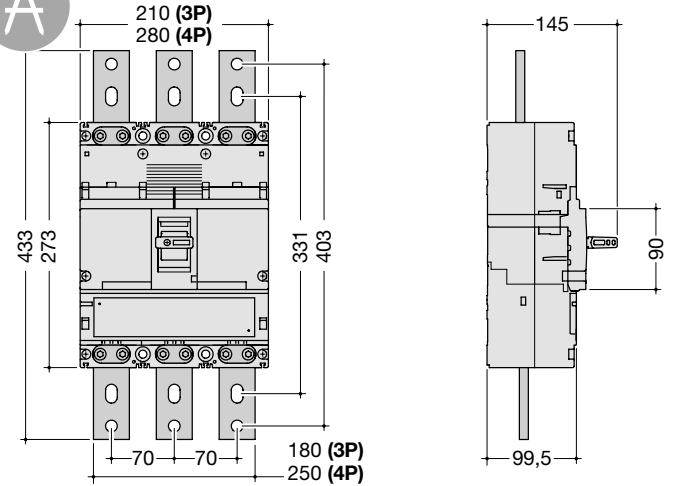
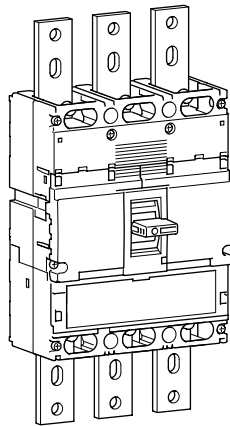

Handle position indicator :
 ① red = ON, ② black = Trip,
 ③ green = OFF (Reset).
 ④ Button, Push-to-Trip

Trip unit settings

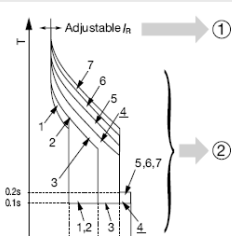

LSI	In A				
	630 / 800 A				
	Long Time Delay		Short Time Delay		Inst li (xlr)
Ir (x In)	tr (s)	I _{sd} (xIr)	t _{sd} (s)		
①	0,4	ok			
	0,5	ok			
	0,63	ok			
	0,8	ok			
	0,9	ok			
	0,95	ok			
	1	ok			
②	1	11 s at 2 xIr	2,5	0,1	14 (Max 12 x In)
	2	21 s at 2 xIr	5		
	3	5 s at 6 xIr	10		
	4	10 s at 6 xIr	0,2		
	5	19 s at 6 xIr			
	6	29 s at 6 xIr			
	7	29 s at 6 xIr			

③ Neutral protection

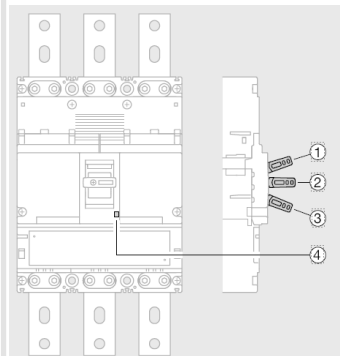

LSI	220 / 240 V AC		380 / 415 V AC	660 / 690 V AC	
	630 / 800 A	1000 A	630 / 800 / 1000 A	630 / 800 / 1000 A	
HNE	I _{cu} (kA)	85	75	50	20
	I _{cs} (kA)	85	75	50	20

JF6/JF8 3 Pole 630A MCCB incomer kit

630A Incomer kits contain:

- 3 x Phase extension links
- 3 x spreader links
- 6 x Phase link Allen fixing bolts and washers (M10)
- 4 x Long fixing screws
- 1 x MCCB
- 3 x M8 120mm Lug
- Terminal covers

Ensure terminal shrouds are removed before fitting.

17mm & 19 mm
A/F

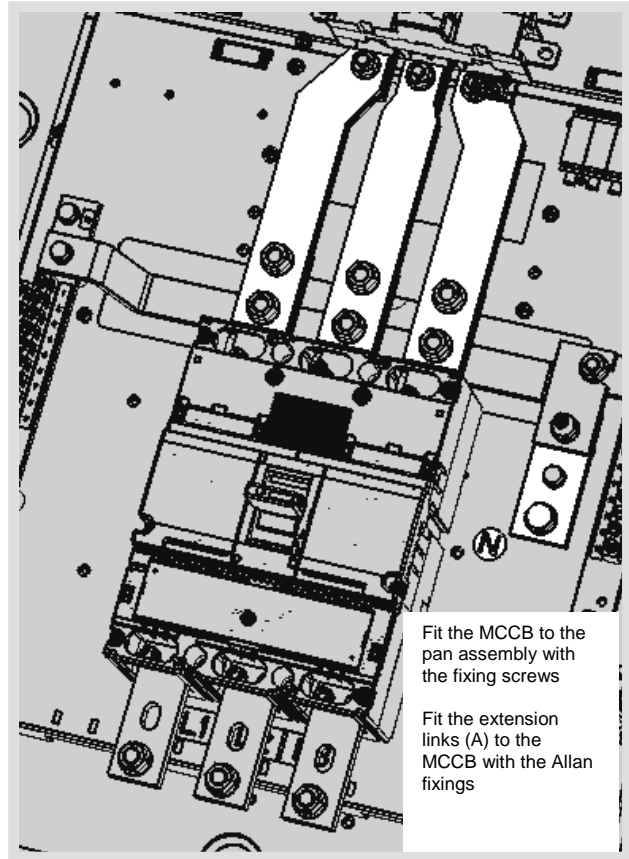
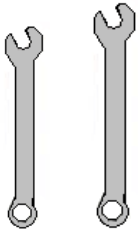

Fit the MCCB to the pan assembly with the fixing screws

Fit the extension links (A) to the MCCB with the Allan fixings

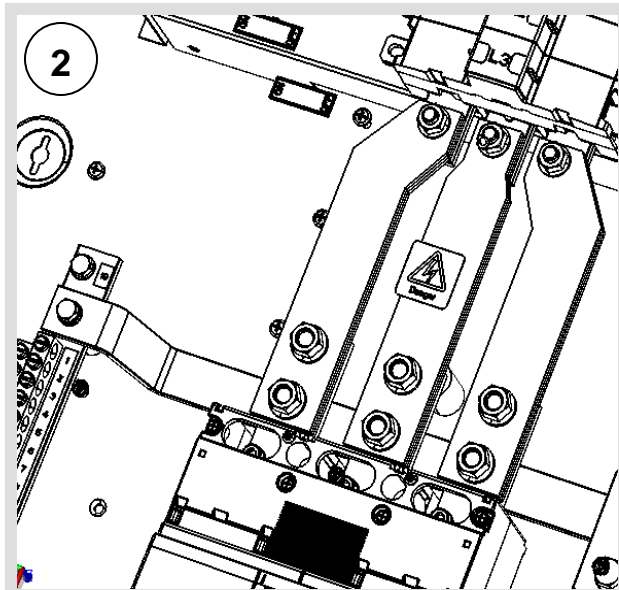

Connect the extension links to the busbar with the 3 x M10 coach bolts. Hand tighten at this stage. Now tighten the MCCB fixing screws to secure the MCCB to the pan assembly.

Once the MCCB is in place tighten all M10 electrical connections to **22Nm** and M12 to **45-65Nm**
Fit the terminal shrouds

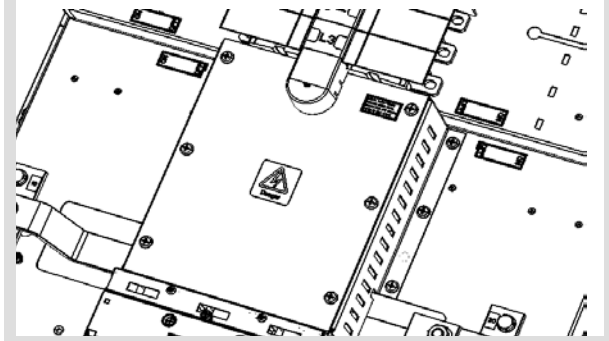

JF6/JF8 4 Pole 630A MCCB incomer kit

630 4 pole incomer kits contain:

- 3 x Line extension links
- 2 x Neutral links
- 4 x spreader links
- 8 x Phase link Allen fixing bolts and washers (M10)
- 4 x Long fixing screws
- 1 x MCCB
- 4 x M8 120mm Lug
- Terminal covers

Ensure terminal shrouds are removed before fitting.

12 mm, 17mm & 19 mm
A/F

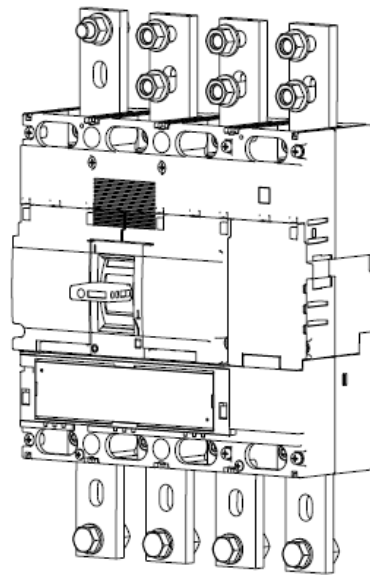
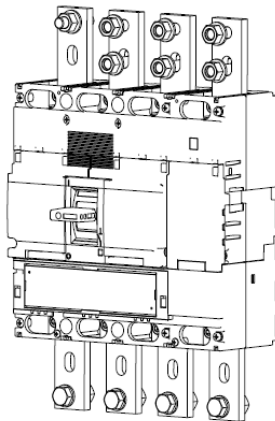
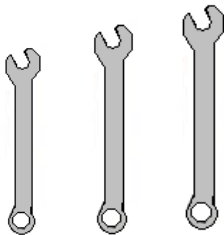

Remove the busbar shield.

Fit the MCCB to the pan assembly with the fixings provided

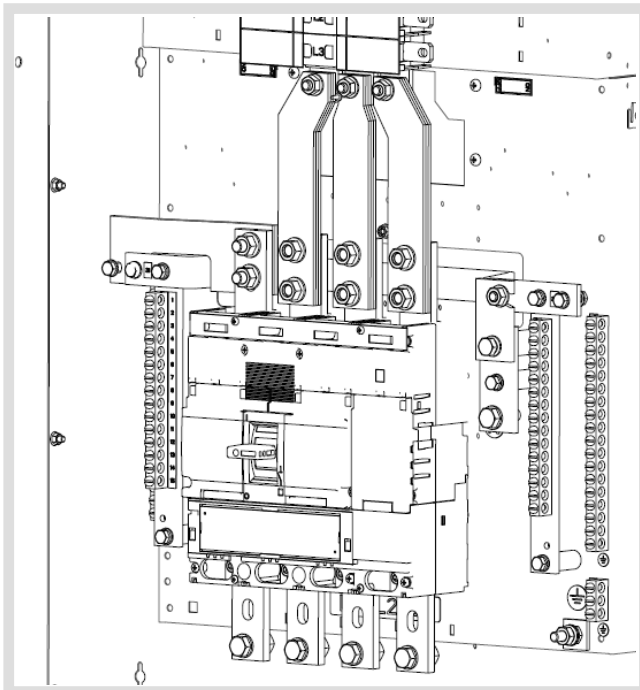

Connect the extension links to the busbar with the 3 x M10 coach bolts the M8 coach bolts. Hand tighten at this stage.

Connect the 2 neutral links with the M8 coach bolts, making sure they are fitted under the Neutral phase of the MCCB. Hand tighten at this stage.

Now tighten the MCCB fixing screws to secure the MCCB to the pan assembly.

Once the MCCB is in place tighten all M10 electrical connections to **22Nm** and M12 to **45-65Nm**. Tighten all **M8** connections to **13Nm**. Fit the terminal shrouds

