



Tebis application software



Dimmer KNX STXA210AN + STXA213N

Electrical / Mechanical characteristics: see product user manual

	Product reference	Product designation
	TXA210AN TXA210N TXA213N	Dimmer 1 x 600W Dimmer 1 x 300W Dimmer 3 x 300W

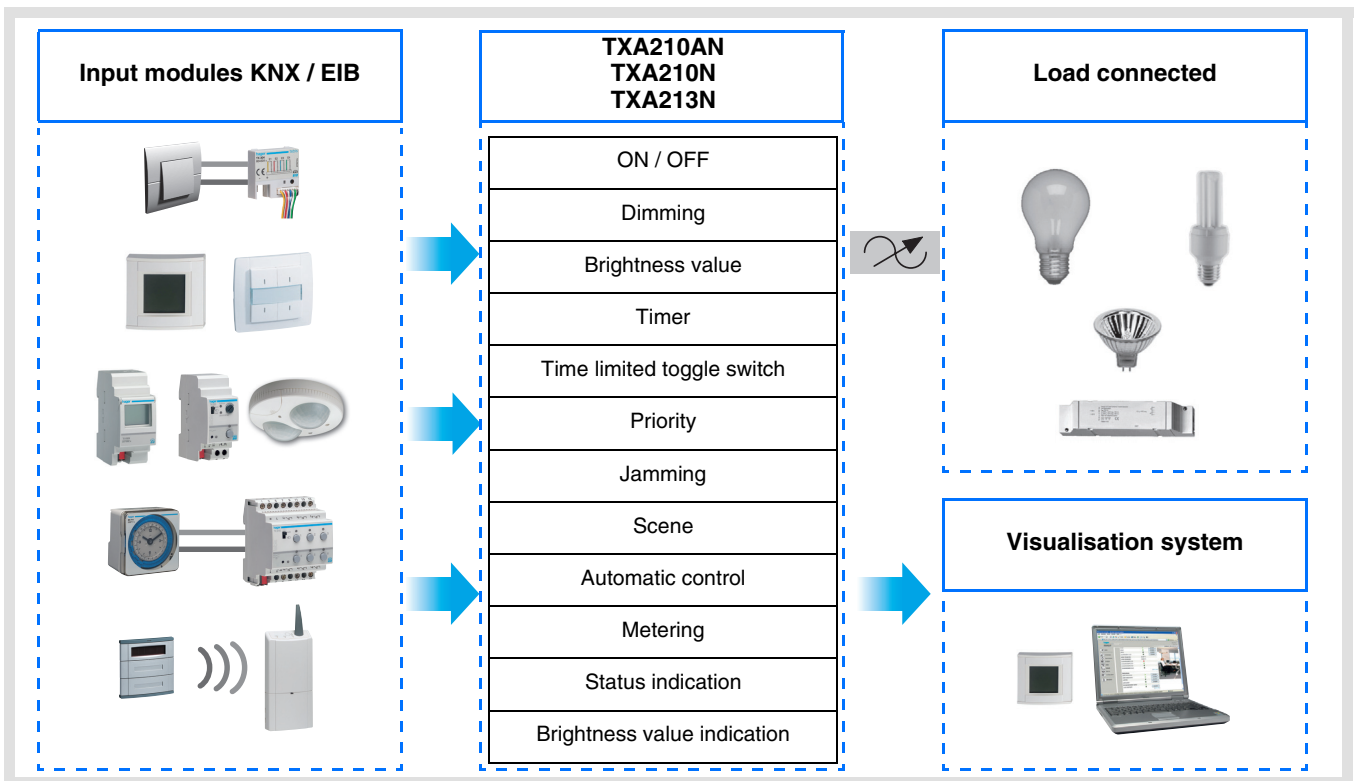

Summary

1. Description of the Dimming functions of STXA210AN-STXA213N applications.....	2
2.1 Common settings.....	3
2.2 Objects List.....	5
2.3 Function Description.....	5
2. Dimming functions configuration and setting	3
3. Main characteristics	23
4. Physical addressing	23

1. Description of the Dimming functions of STXA210AN-STXA213N applications

The STXA210AN and STXA213N application software is used to individually configure each output for the Dimming applications.

The main functions are the following:

■ ON / OFF

The ON / OFF function is used to switch a lighting circuit ON or OFF.

- ON: switching ON at the lighting level defined by parameters. Switching ON can be gradual or instantaneous,
- OFF: switching OFF. Switching off can be progressive or instantaneous.

The control can come from push buttons.

■ Relative or absolute dimming (Brightness value)

The relative dimming allows increasing or decreasing the lighting level as long as a push button is pressed down. The speed of dimming is configurable. The absolute dimming allows defining in % the lighting level to reach by means of the **Lighting level** object.

■ Timer

The Timer function is used to switch a lighting circuit ON or OFF for an adjustable time. Depending on the operation mode selected, the output may be delayed for ON or OFF switching. An adjustable cut-OFF pre-warning indicates the end of the delay time by dividing the lighting level by two. The timer can be interrupted before the end of the time delay.

■ Time limited toggle switch

The Time delayed switch function combines a toggle function and a cut-OFF delay. Pressing briefly a push button inverts the output. If the output is at ON, it switches automatically to OFF after a programmable time delay (to prevent it being forgotten).

Application: Lighting for attics, cellars, store rooms, etc..

■ Priority

The Priority function allows overriding an output to an adjustable lighting level. This command has the highest priority. No other command is taken into account if a priority is active. Only a priority end command re-enables the other commands.

Application: maintaining lighting ON for safety reasons.

■ Scene

The Scene function groups a set of outputs. These outputs can be set to an adjustable predefined status. Pressing a push button activates a scene. The dimming speeds to achieve these levels of lighting are configurable.

■ Metering

The Metering function is used to measure the total duration at ON or at OFF for an output. A set-point triggering an alarm may be programmed.

■ Adjustment of the minimum and maximum limits of the dimming range

This function is used to set the minimum and maximum dimming limits for each output. These limits can be adjusted by ETS configuration or locally on the front face of the product.

■ Selection of the number of outputs used*

The product allows 1, 2 or 3 lighting circuits to be controlled. The maximum available power per output depends on the number of outputs used. The total power is limited to 900W:

- 1 output used: 900W
- 2 outputs used: one 600W output and one 300W output
- 3 outputs used: 300W per output

■ Manu Mode

Manu Mode is used to isolate the product from the bus. In this mode it is possible to force the level of lighting of the lighting circuits locally. These parameters can also be adjusted in ETS. A local adjustment on the product overrides the last values downloaded.

* only reference TXA213N.

■ Expert mode

Expert mode is used to force dimming mode manually. It is possible to carry out this adjustment locally on the front face of the product or via an ETS parameter.

2. Dimming functions configuration and setting

2.1 Common settings

■ Selection of the number of outputs*

This parameter is used to select the number of outputs used.

→ Parameter Setting screen

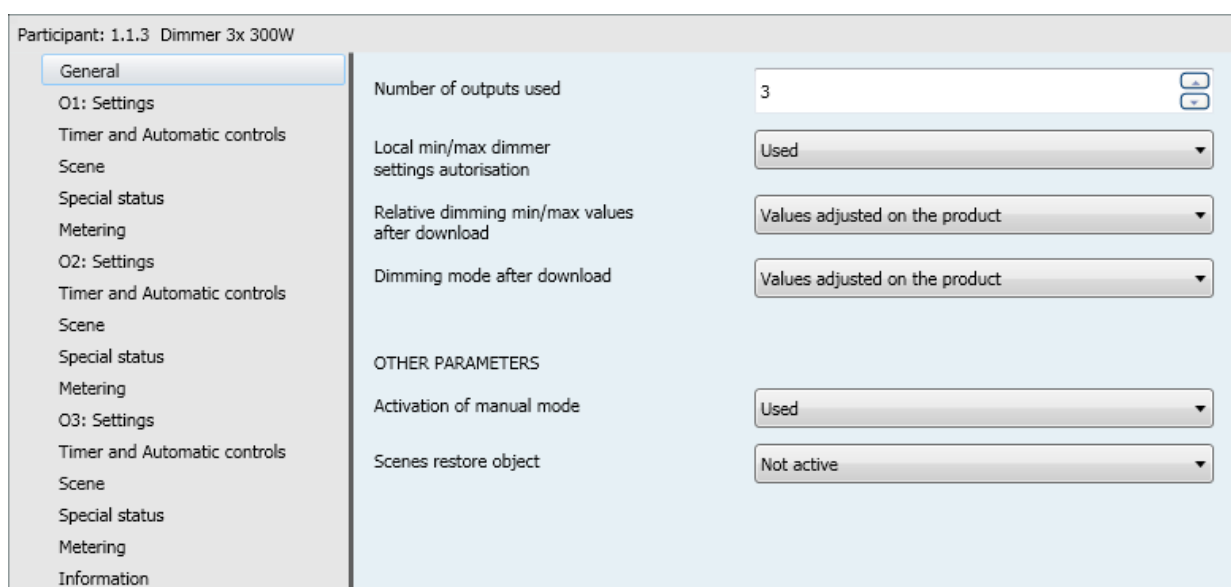

Screen 1

Designation	Description	Values
Number of outputs used*	This parameter is used to select the number of outputs used.	1, 2, 3 Default value: 3
Activation of manual mode**	This parameter enables or disables the 2 position switch located on the front side of the product. This switch is used to select Manu or Auto mode. In Manu mode, the outputs can be controlled using the push buttons on the front of the product. In Auto mode, the orders from the bus control the outputs.	Manual mode authorised, Manual mode inhibited, Time limited manual mode. <ul style="list-style-type: none"> Manual mode authorised: Manual mode can be activated at any time, Manual mode inhibited: The switch is permanently inhibited. It is impossible to switch to manual mode. Time limited manual mode: Manual mode can be activated for a configurable duration. Default value: Manual mode authorised
Duration of manual mode activation***	This parameters defines the duration of activation of the manual mode.	15 min, 30 min, 60 min Default value: 15 min

Designation	Description	Values
Scenes restore object (See also Scene function)	If the value is Active, the values associated with the scenes during the last download are restored during the receipt of the object.	Not active, Active Default value: Not active

* only reference TXA213N.

** If the position of the switch is not consistent with the status of the product, the indicators associated with the outputs light up in sequence.

*** This parameter is only visible if the **Activation of manual mode** parameter has the value: Time limited manual mode.

■ Adjustment of the minimum and maximum dimming values

The relative dimming range is adjustable on the product or by ETS configuration.

A. Local adjustment

A 4 position switch on the front of the product is used to select the following modes:

TXA210N-210AN	TXA213N
Auto	Auto
Min	Min
Max	Max
Manu	Manu

The Min and Max positions are used to adjust the minimum and maximum lighting levels for the outputs. This adjustment is performed by storing the current value of the output by a long press on the push button corresponding to the output on the front of the product.

B. Parameters ETS

In case of ETS downloading, it is possible to:

- Not modify the limits set locally,
- Replace the limits set locally by the configured values,
- Replace the dimming mode selected locally by the configured values.

Designation	Description	Values
Local min / max dimmer settings autorisation	This parameter is used to authorise or prohibit the taking into account of the Min and Max positions of the switch.	Forbidden, Authorized Default value: Authorized
Relative dimming min / max values after download	This parameter authorises or prohibits the taking into account of the limit values for the dimming range configured with the ETS.	Values adjusted on the product, Values settings in ETS Default value: Values adjusted on the product
Dimming mode after download	This parameter is used to define which setting is taken into account after downloading.	Values adjusted on the product, Values settings in ETS Default value: Values adjusted on the product

2.2 Objects List

0	Output 1	ON / OFF	1 bit	C	R	W	-	U
1	Output 1	Dimming	4 bit	C	R	W	-	U
2	Output 1	Brightness value	1 Byte	C	R	W	-	U
3	Output 1	Timer	1 bit	C	R	W	-	U
4	Output 1	Priority	2 bit	C	R	W	-	U
5	Output 1	Scene	1 Byte	C	R	W	-	U
6	Output 1	Status indication ON / OFF	1 bit	C	R	-	T	U
7	Output 1	Brightness value	1 Byte	C	R	-	T	U
8	Output 2	ON / OFF	1 bit	C	R	W	-	U
9	Output 2	Dimming	4 bit	C	R	W	-	U
10	Output 2	Brightness value	1 Byte	C	R	W	-	U
11	Output 2	Timer	1 bit	C	R	W	-	U
12	Output 2	Priority	2 bit	C	R	W	-	U
13	Output 2	Scene	1 Byte	C	R	W	-	U
14	Output 2	Status indication ON / OFF	1 bit	C	R	-	T	U
15	Output 2	Brightness value	1 Byte	C	R	-	T	U
16	Output 3	ON / OFF	1 bit	C	R	W	-	U
17	Output 3	Dimming	4 bit	C	R	W	-	U
18	Output 3	Brightness value	1 Byte	C	R	W	-	U
19	Output 3	Timer	1 bit	C	R	W	-	U
20	Output 3	Priority	2 bit	C	R	W	-	U
21	Output 3	Scene	1 Byte	C	R	W	-	U
22	Output 3	Status indication ON / OFF	1 bit	C	R	-	T	U
23	Output 3	Brightness value	1 Byte	C	R	-	T	U
26	Output 1	Faulty load	1 bit	C	R	-	T	U
27	Output 1	Jamming	1 bit	C	R	W	-	U
29	Output 1	Toggle switch	1 bit	C	R	W	-	U
31	Output 1	Load memorisation	1 bit	C	R	W	-	U
35	Output 2	Faulty load	1 bit	C	R	-	T	U
36	Output 2	Jamming	1 bit	C	R	W	-	U
38	Output 2	Toggle switch	1 bit	C	R	W	-	U
40	Output 2	Load memorisation	1 bit	C	R	W	-	U
44	Output 3	Faulty load	1 bit	C	R	-	T	U
45	Output 3	Jamming	1 bit	C	R	W	-	U
47	Output 3	Toggle switch	1 bit	C	R	W	-	U
49	Output 3	Load memorisation	1 bit	C	R	W	-	U
54	All lighting out	Maintenance	2 Byte	C	R	-	T	U

2.3 Function Description

Dimmers KNX TXA210N, TXA210AN and TXA213N have a load memorisation function in order to control dimmable fluocompact lamps and LED lamps more effectively. These products also have a priority function for the dimming mode which allows the desired dimming modes to be selected.

The **Memorisation** object is used to launch the memorisation procedure. Memorisation of the load can also be launched thanks to a specific sequence of presses on a KNX push button:

- With a KNX push button configured for dimming, give 5 short presses (5 ON; 5 OFF or 5 ON / OFF) followed by a long press until the load switches off,
- Give a brief press on the push button to launch memorisation (two presses to return to factory dimming mode).

This operation lasts approximately 30 s and varies the level of lighting.

After this memorisation, the load lights at the maximum level and flashes once to indicate that memorisation is terminated.

Depending on the load connected, the minimum lighting level can be modified.

This memorisation can be authorised or not authorised thanks to the memorisation authorisation parameter.

Dimming mode can be configured to a fixed value using the **Selection of the dimmig mode** parameter.

Designation	Description	Values
Dimming mode selection*	This parameter is used to define the dimming mode applied.	Fluocompact, Capacitive load, Induction load, LED load, Load memorisation, Factory mode Default value: Factory mode
Authorisation of the expert button	This parameter is used to define if it is possible to modify the dimming mode using the expert button on the front of the product.	Used, Not used Default value: Used

Designation	Description	Values
Load memorisation	This parameter defines if the load memorisation function can be used or not.	Used, Not used Default value: Not used

This parameter is only available when the **Dimming mode after download** parameter is defined as the value configured in ETS.

■ **ON / OFF, Status indication and Brightness value indication functions**

The ON/OFF function enables switching the output to ON or to OFF using the **ON/OFF** object.

- ON: switching ON at the lighting level defined by parameters. Switching ON can be gradual or instantaneous.
- OFF: switching OFF. Switching off can be progressive or instantaneous.

The speed of dimming is configurable.

The speed at which the lighting switches on and off are configured for the ON / OFF function, the values of these parameters are re-used by the Absolute dimming, Timer and Priority functions.

The output status and the lighting level are indicated on the bus by the **Status indication** object and **Brightness value indication** object.

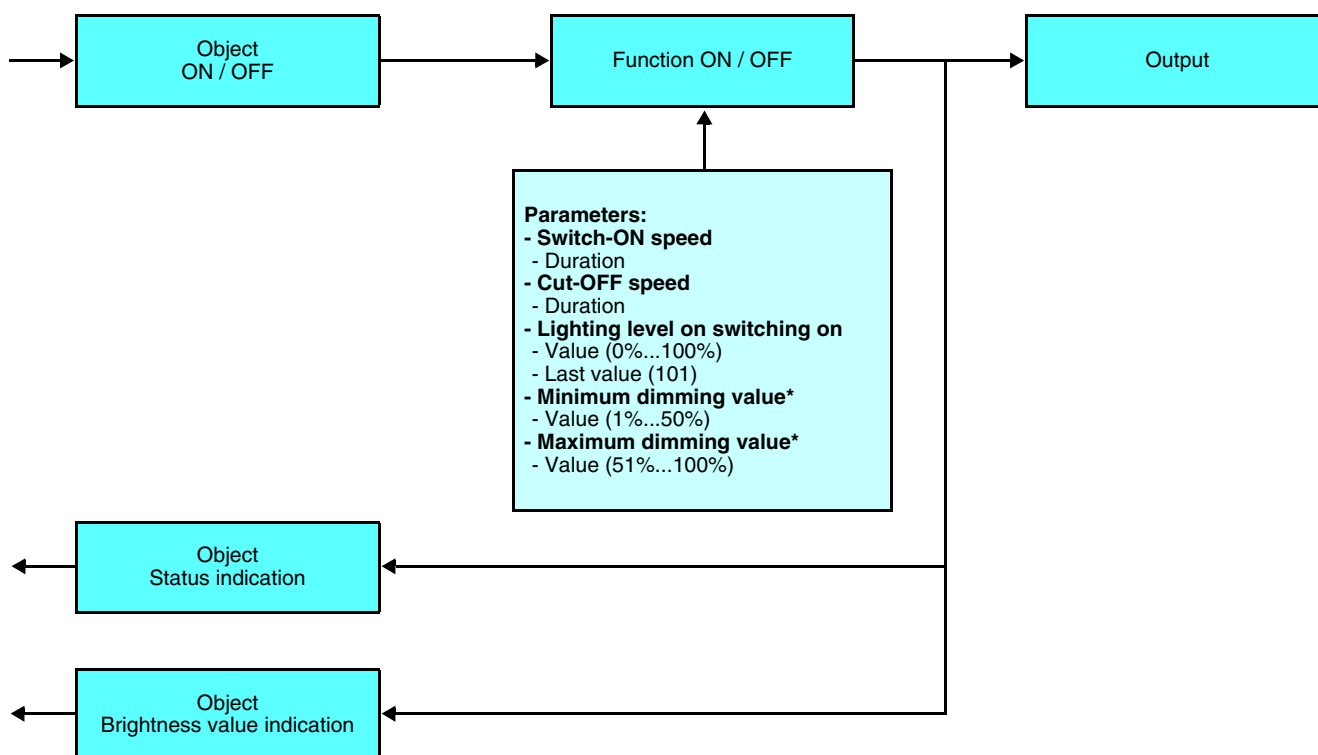

* These parameters are only visible if the **Relative dimming limits** parameter during downloading has the value: Values settings in ETS.

■ **Operating principle**

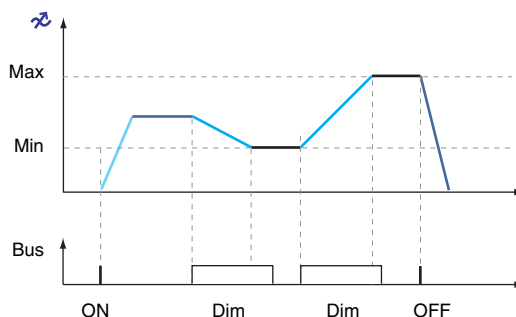

	Switch-ON speed
	Relative dimming speed
	Cut-OFF speed
	Lighting level on switching on
	Min and max lighting level

→ Parameter Setting screen

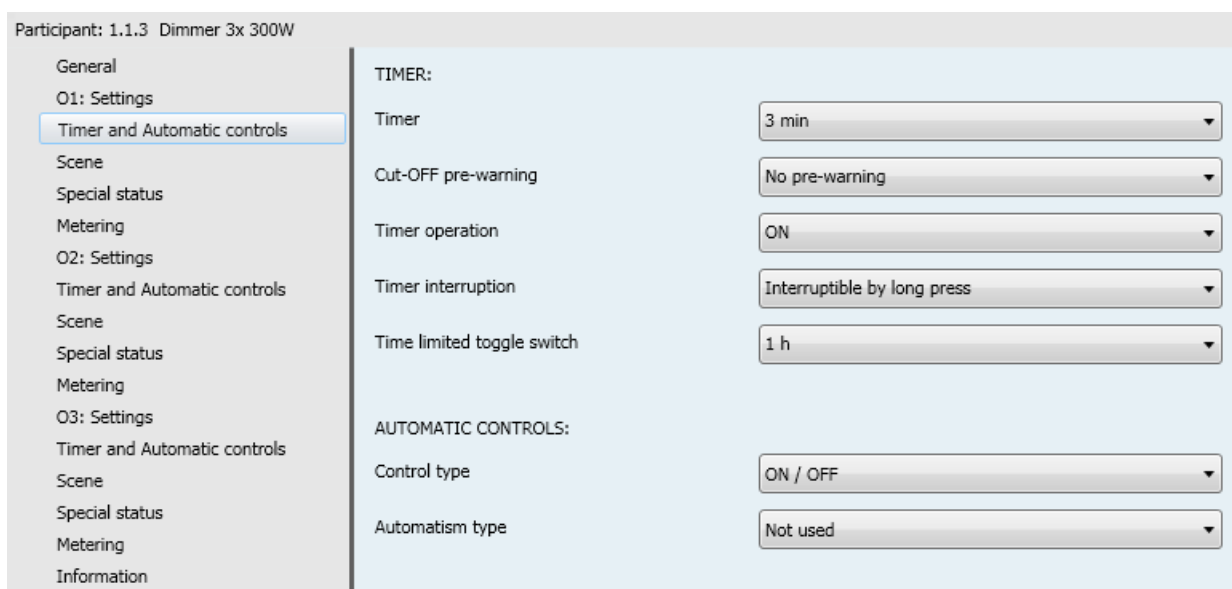

Screen 2

Designation	Description	Values
Switch-ON speed	This parameter defines the dimming speed to achieve the lighting level when switching on.	0 s, 1 s, 2 s, 3 s, 4 s, 5 s, 6 s, 9 s, 15 s, 30 s, 60 s, 2 min, 5 min, 10 min, 20 min, 30 min Default value: 0 s
Cut-OFF speed	This parameter defines the dimming speed for switching off the light.	0 s, 1 s, 2 s, 3 s, 4 s, 5 s, 6 s, 9 s, 15 s, 30 s, 60 s, 2 min, 5 min, 10 min, 20 min, 30 min Default value: 0 s
Lighting level on switching on	This parameter defines the lighting level when switching on.	From 0% to 100% in intervals of 1%, 101 (Last value) Default value: 101 (Last value)
Minimum dimming value*	This parameter defines the minimum value for the lighting level during dimming.	From 1% to 50% in intervals of 1% Default value: 1%
Maximum dimming value*	This parameter defines the maximum value of the lighting level during dimming.	From 51% to 100% in intervals of 1% Default value: 100%

* These parameters are only visible if the **Relative dimming limits** parameter during downloading has the value: Values settings in ETS.

■ Dimming function

The dimming can be relative or absolute.

A. Relative dimming

The relative dimming allows increasing or decreasing the lighting level of the lighting circuit as long as a push button is pressed down.

The relative dimming function is started by the **Dimming** object.

The speed of dimming is configurable.

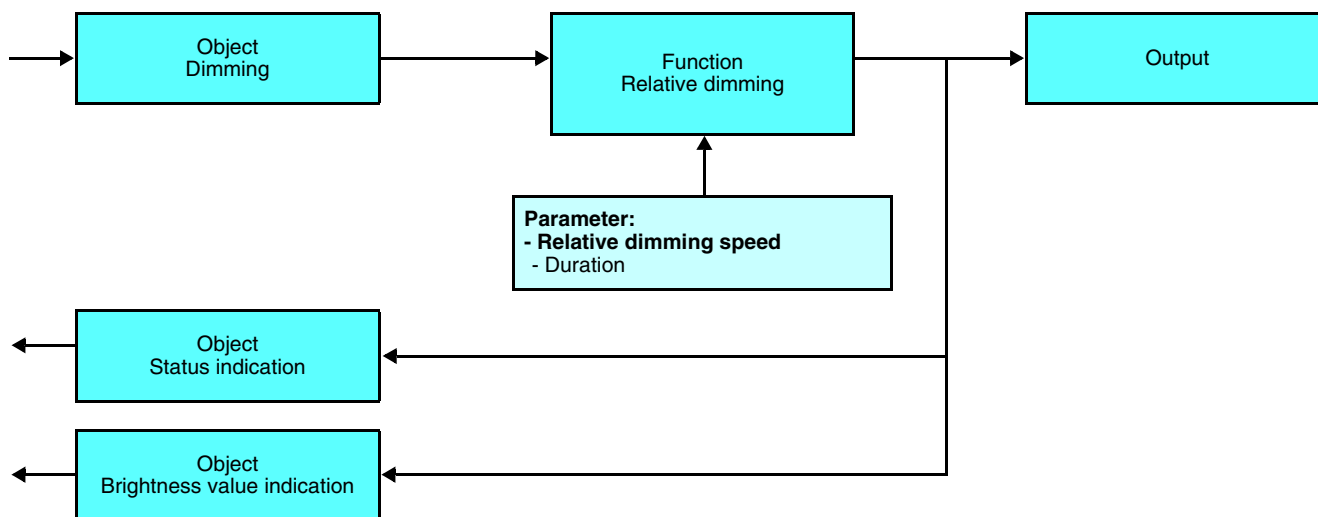

Parameter Setting screen: See Screen

Designation	Description	Values
Relative dimming speed	This parameter defines the dimming speed to go from level 0% to level 100%.	1 s, 2 s, 3 s, 4 s, 5 s, 6 s, 9 s, 15 s, 30 s, 60 s Default value: 4 s

B. Absolute dimming

The parameters set in the ON/OFF function are also applied to the Absolute dimming function. No specific adjustment needs to be performed.

The Absolute dimming function allows applying a brightness level to the lighting circuit when switching it ON or OFF.

The absolute dimming function is started by the **Brightness value** object.

The dimming speed is configurable (same values as for the ON/OFF function).

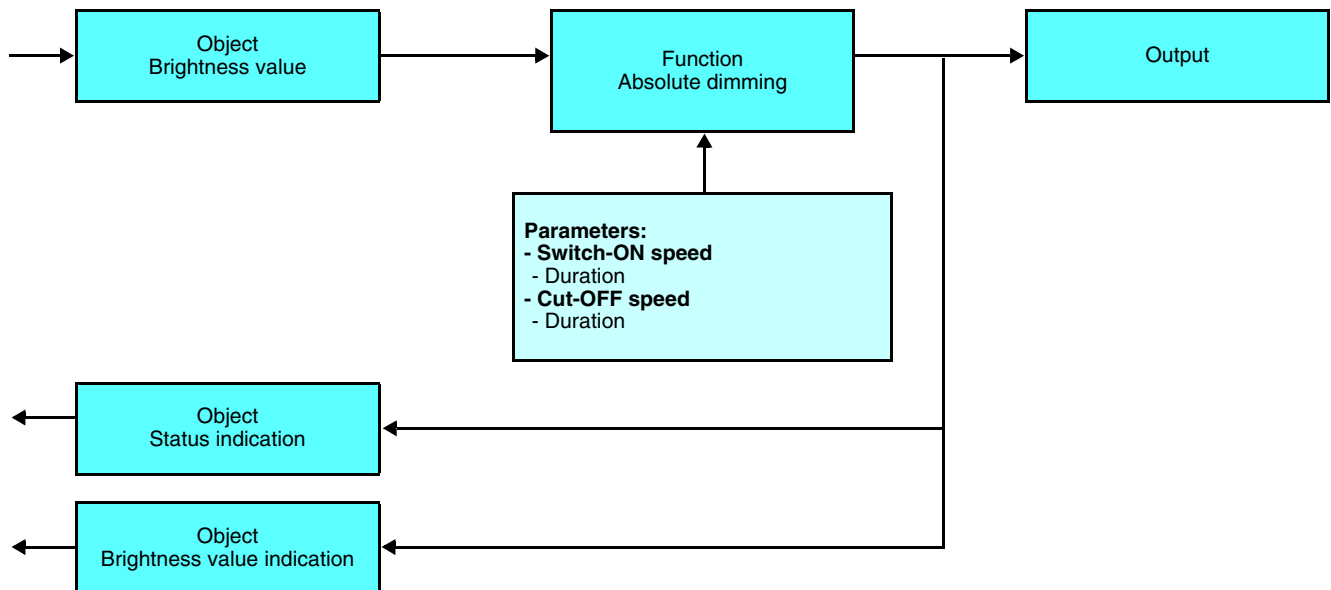

Parameter Setting screen: See Screen

Designation	Description	Values
Switch-ON speed (As for the ON/OFF function)	This parameter defines the dimming speed to achieve the lighting level when switching on.	0 s, 1 s, 2 s, 3 s, 4 s, 5 s, 6 s, 9 s, 15 s, 30 s, 60 s, 2 min, 5 min, 10 min, 20 min, 30 min Default value: 0 s
Cut-OFF speed (As for the ON/OFF function)	This parameter defines the dimming speed for switching off the light.	0 s, 1 s, 2 s, 3 s, 4 s, 5 s, 6 s, 9 s, 15 s, 30 s, 60 s, 2 min, 5 min, 10 min, 20 min, 30 min Default value: 0 s

■ Timer function

The Timer function is used to switch a lighting circuit ON or OFF for an adjustable time. The function is started by the **Timer** object. The dimming speed is configurable (same values as for the ON/OFF function).

Cut-off pre-warning (in ON operation):

An adjustable cut-OFF pre-warning indicates the end of the delay time by dividing the lighting level by two. The Cut-OFF **pre-warning** parameter value defines the time before the end of the delay time, when the pre-warning will be applied.

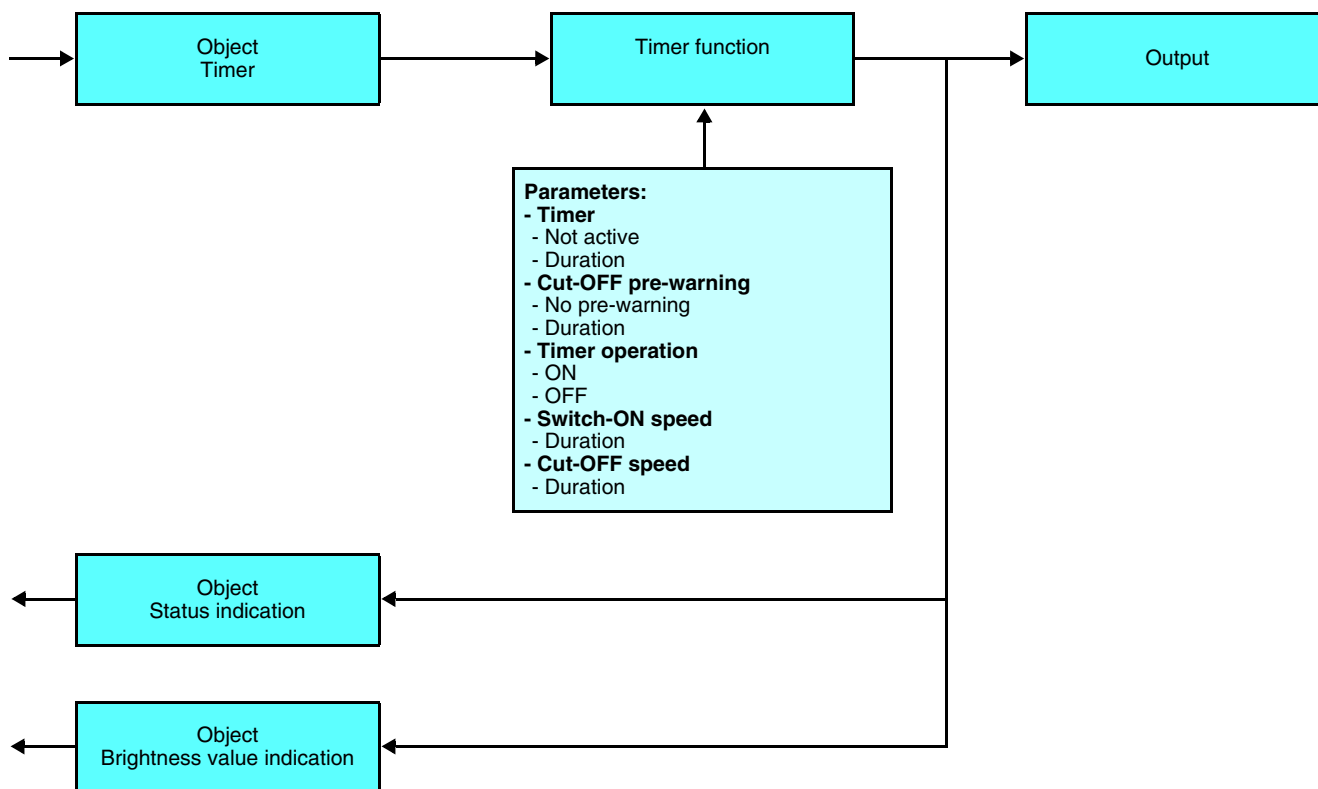

Parameter Setting screen: See Screen

Designation	Description	Values
Timer	This parameter defines the length of the delay time.	Not active, Range [1 s - 24 h]* Default value: 3 min
Cut-OFF pre-warning	The parameter value defines the time before the end of the delay time, when the pre-warning will be applied.	No pre-warning, 15 s, 30 s, 1 min Default value: No pre-warning
Timer operation	This parameter defines whether the delay time triggers an ON or an OFF status.	ON, OFF Default value: ON
Switch-ON speed (As for the ON/OFF function)	This parameter defines the dimming speed to achieve the lighting level when switching on.	0 s, 1 s, 2 s, 3 s, 4 s, 5 s, 6 s, 9 s, 15 s, 30 s, 60 s, 2 min, 5 min, 10 min, 20 min, 30 min Default value: 0 s
Cut-OFF speed (As for the ON/OFF function)	This parameter defines the dimming speed for switching off the light.	0 s, 1 s, 2 s, 3 s, 4 s, 5 s, 6 s, 9 s, 15 s, 30 s, 60 s, 2 min, 5 min, 10 min, 20 min, 30 min Default value: 0 s
Timer interruption	This parameter allows or not the interruption of the timer when the associated push button is pressed for a long time.	Interruptible timer, Non-interruptible timer Default value: Interruptible timer

* Setting range [1 s - 24 h]

1 s, 2 s, 3 s, 5 s, 10 s, 15 s, 20 s, 30 s, 40 s, 45 s, 50 s, 1 min, 1 min 15 s, 1 min 30 s, 2 min, 2 min 30 s, 3 min, 4 min, 5 min, 6 min, 7 min, 8 min, 9 min, 10 min, 11 min, 12 min, 13 min, 14 min, 15 min, 20 min, 30 min, 40 min, 50 min, 1 h, 1 h 30 min, 2 h, 2 h 30 min, 3 h, 3 h 30 min, 4 h, 5 h, 6 h, 12 h, 24 h.

Remark:

- Timer commands repeated n times during the first ten seconds after the beginning of the time delay multiply the duration of the time delay by n times the value of the **Timer** parameter,
- **Timer commands** repeated n times within 10 seconds after the beginning of the delay time restart the timer only once.

■ Time limited toggle switch function

The Time limited toggle switch function is used to create a toggle switch with a configurable cut-off time delay. This function is started by the **Time limited toggle switch object**.

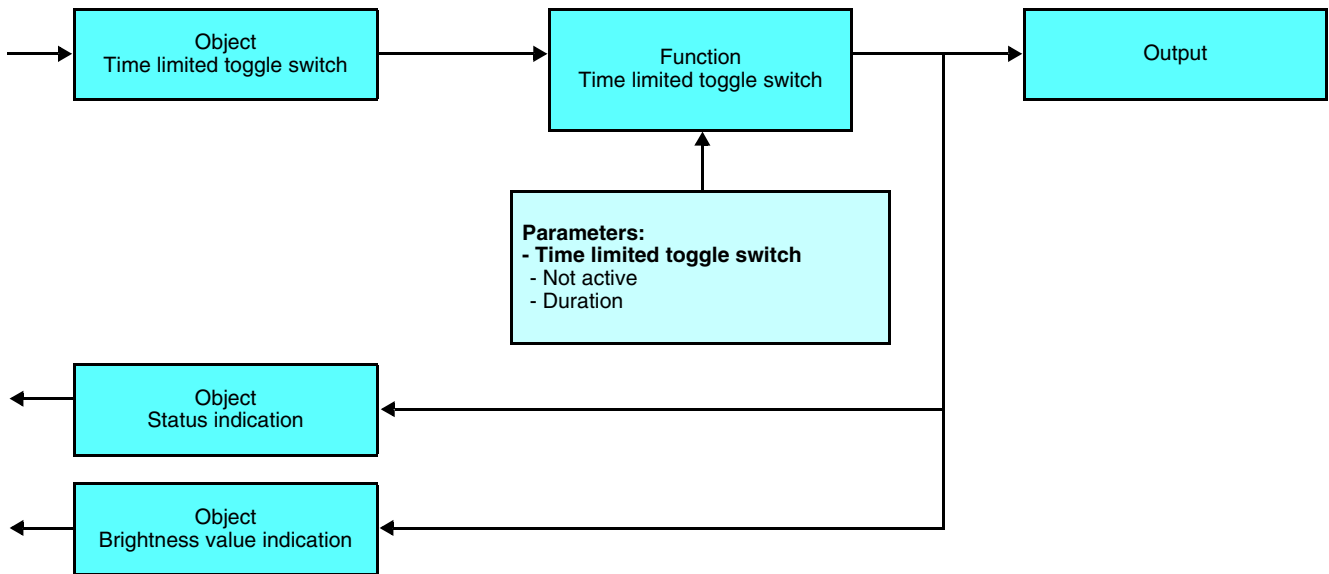

Parameter Setting screen: See Screen

Designation	Description	Value
Time limited toggle switch	This parameter defines the duration of the switch-OFF delay time.	Not active, Range [0.5 s - 24 h]* Default value: 1 h

* Setting range [0.5 s - 24 h]

0.5 s, 1 s, 2 s, 3 s, 5 s, 10 s, 15 s, 20 s, 30 s, 40 s, 45 s, 50 s, 1 min, 1 min 15 s, 1 min 30 s, 2 min, 2 min 30 s, 3 min, 4 min, 5 min, 6 min, 7 min, 8 min, 9 min, 10 min, 11 min, 12 min, 13 min, 14 min, 15 min, 20 min, 30 min, 40 min, 50 min, 1 h, 1 h 30 min, 2 h, 2 h 30 min, 3 h, 3 h 30 min, 4 h, 5 h, 6 h, 12 h, 24 h.

■ Priority function

The Priority function allows the outputs to be forced and maintained at a definite ON or OFF status imposed by the input. This function is started by the **Priority** object. The lighting level for the Priority ON is configurable.

The dimming speed is configurable (same values as for the ON/OFF function).

Priority is the function with the highest priority. Only a cancellation command for the priority can end the priority and authorise the bus commands to be followed again.

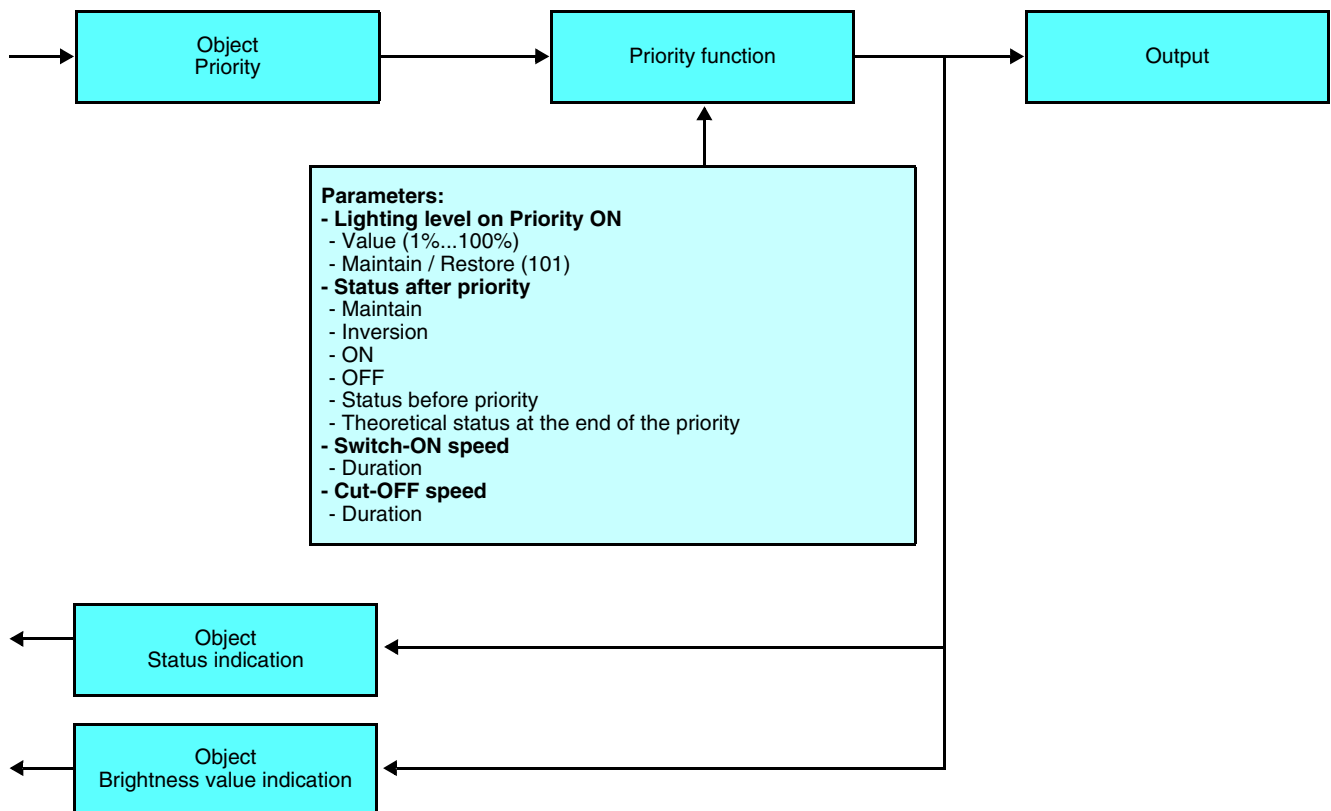

Parameter Setting screen: See Screen

→ Description of the **Priority** object

Bit 1	Bit 0
Output behaviour	

Output behaviour	00 = Priority end 01 = Priority end 10 = Priority OFF 11 = Priority ON
------------------	---

→ Parameter Setting screen

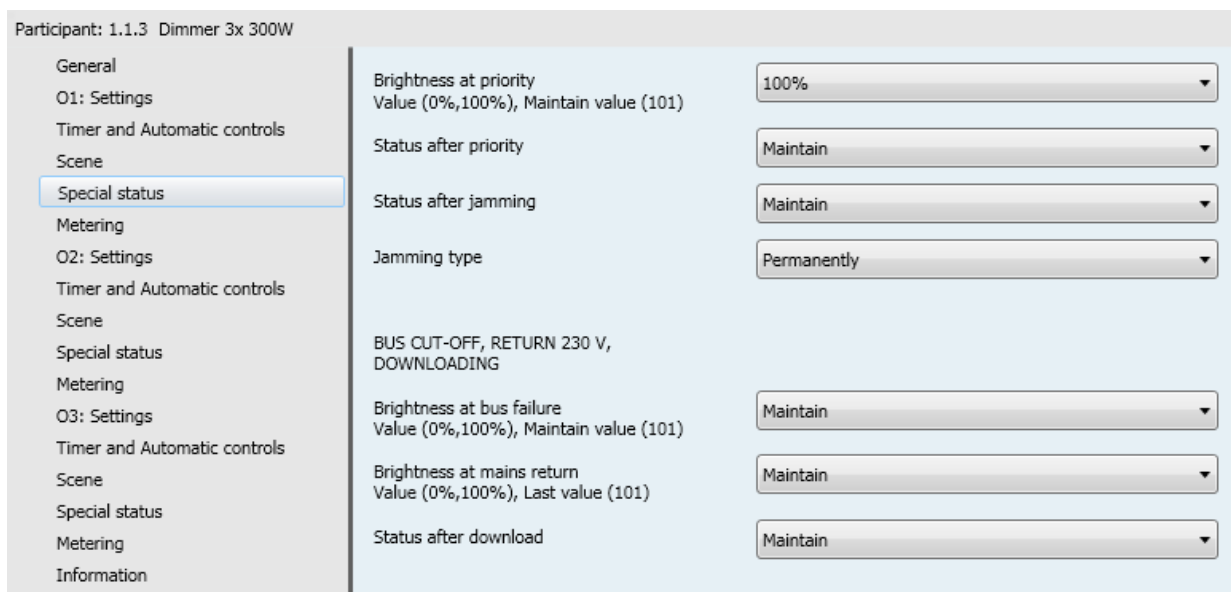

Screen 3

Designation	Description	Values
Lighting level on Priority ON	This parameter defines the lighting level for the priority.	<p>From 1% to 100% in intervals of 1%, 101</p> <p>101:</p> <ul style="list-style-type: none"> If the output is off: Re-establishment of the level defined by the Lighting level when lighting is switched on parameter, If the output is on: Maintains the level before the priority. <p>Default value: 100%</p>
Status after priority	This parameter defines the level of lighting applied at the end of the priority.	<p>Maintain, Inversion, Status before priority</p> <ul style="list-style-type: none"> Maintain: Maintains the output at the status active during Priority, Inversion: Inversion of the output's status with regards to the status active during Priority (ON to OFF and OFF to ON), ON: Switch the output to ON, OFF: Switch the output to OFF, Status before priority: Switch the output to the status in place before the Priority control, Theoretical status at the end of the priority: Switch the output to the status which would be in place if no priority control had taken place. <p>Default value: Maintain</p>
Switch-ON speed (As for the ON/OFF function)	This parameter defines the dimming speed to achieve the lighting level when switching on.	<p>0 s, 1 s, 2 s, 3 s, 4 s, 5 s, 6 s, 9 s, 15 s, 30 s, 60 s, 2 min, 5 min, 10 min, 20 min, 30 min</p> <p>Default value: 0 s</p>
Cut-OFF speed (As for the ON/OFF function)	This parameter defines the dimming speed for switching off the light.	<p>0 s, 1 s, 2 s, 3 s, 4 s, 5 s, 6 s, 9 s, 15 s, 30 s, 60 s, 2 min, 5 min, 10 min, 20 min, 30 min</p> <p>Default value: 0 s</p>

■ Jamming function

The Jamming function allows the outputs to be locked in their current status.

This function is started by the **Jamming** object. The Jamming function is the function with the second highest priority after Priority. A **Jamming end** command ends the jamming and allows again taking the commands from the bus into consideration. A **Priority** command ends the **Jamming**.

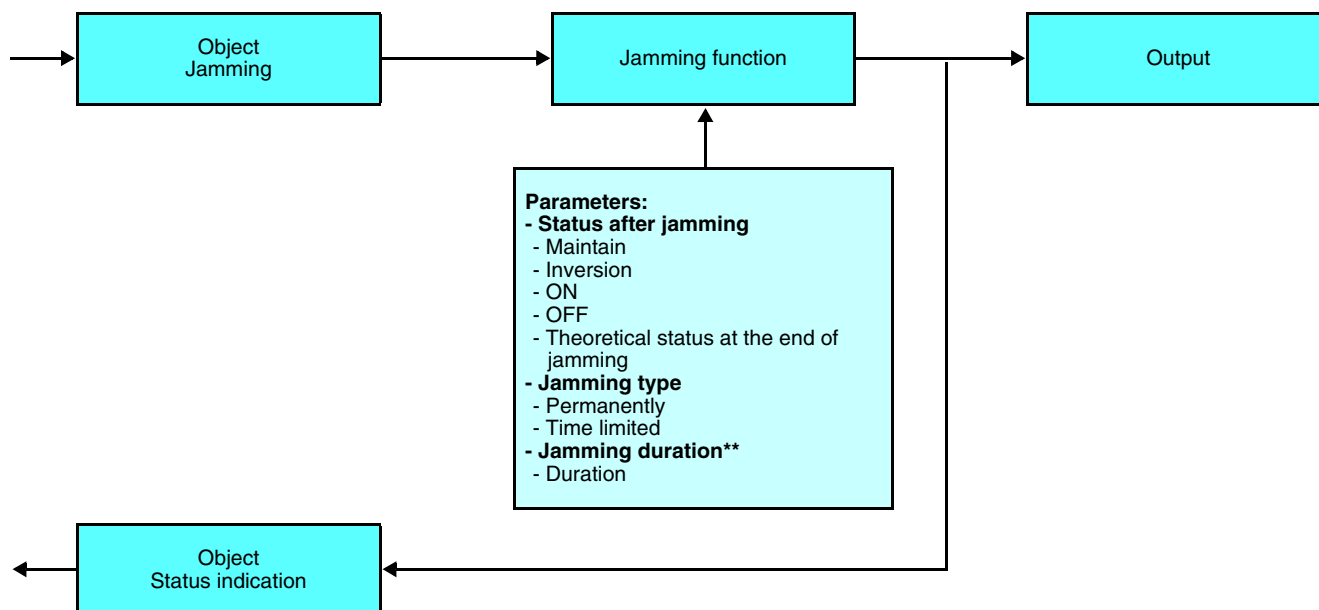

Parameter Setting screen: See Screen

Designation	Description	Value
Status after jamming	This parameter defines the output status to be applied at the end of the Jamming.	Maintain, Inversion, ON, OFF, Theoretical status at the end of jamming <ul style="list-style-type: none"> Maintain: Maintains the output at the status active during Jamming. Inversion: Inversion of the output status with regards to the status active during Jamming (ON to OFF and OFF to ON). ON: Switch the output to ON, OFF: Switch the output to OFF, Theoretical status at the end of jamming: Switch the output to the status which would be in place if no jamming control had taken place. Default value: Maintain
Jamming type	This parameter defines whether Jamming is permanent or time limited.	Permanently, Time limited <ul style="list-style-type: none"> Time limited: Jamming is active for a parameterisable limited duration. Default value: Permanently
Jamming duration**	This parameter defines the Jamming duration.	Not active, Range [0 s - 24 h]* Default value: 1 h

* Setting range [0 s - 24 h]

0 s, 1 s, 2 s, 3 s, 5 s, 10 s, 15 s, 20 s, 30 s, 40 s, 45 s, 50 s, 1 min, 1 min 15 s, 1 min 30 s, 2 min, 2 min 30 s, 3 min, 4 min, 5 min, 6 min, 7 min, 8 min, 9 min, 10 min, 11 min, 12 min, 13 min, 14 min, 15 min, 20 min, 30 min, 40 min, 50 min, 1 h, 1 h 30 min, 2 h, 2 h 30 min, 3 h, 3 h 30 min, 4 h, 5 h, 6 h, 12 h, 24 h.

** This parameter is only visible if the **Jamming type** parameter has following value: Time limited.

■ Scene function

A scene is used to control a group of outputs. Each of the outputs in the group will be set to a status pre-defined for the scene. A scene has been initiated by the object **Scene**.

For each scene, it is possible to configure the lighting level and the dimming speed to achieve this level.

The group of outputs is created in advance by establishing the link between the outputs that are to be part of the scene and the push button which initiates the scene. Each output can be integrated in 32 different scenes.

The status of each output may be defined by parameterising, by learning in the room using the push buttons of the installation or on the product.

A. Configuration and storing by parameterisation

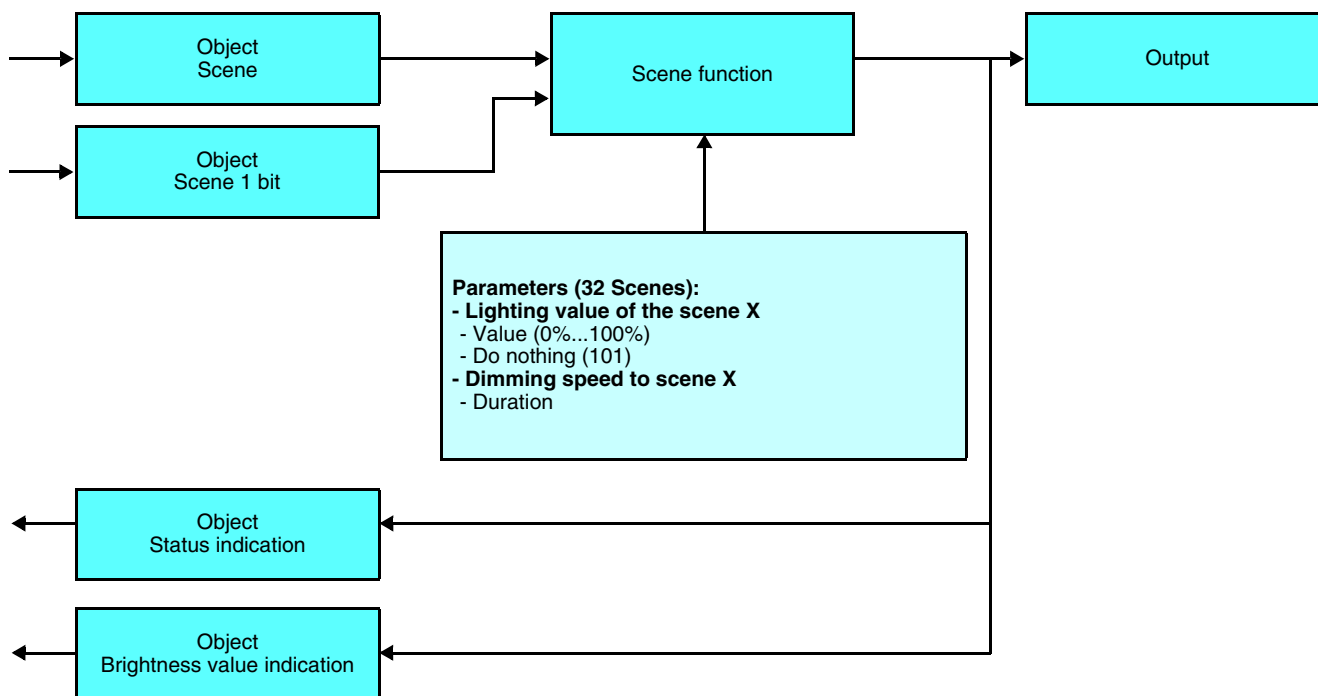

7	6	5	4	3	2	1	0
Learn	x	Scene number					

Description of the **Scene** object (1 byte)

Operating principle

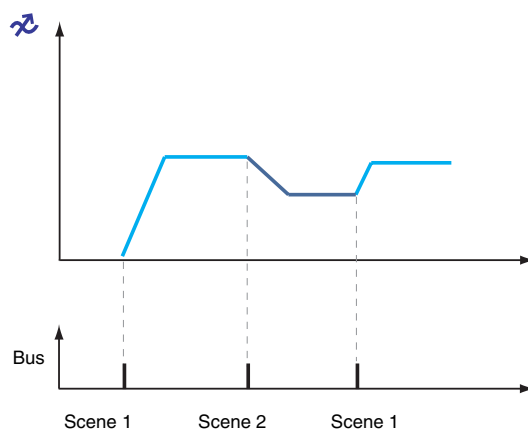

→ Parameter Setting screen

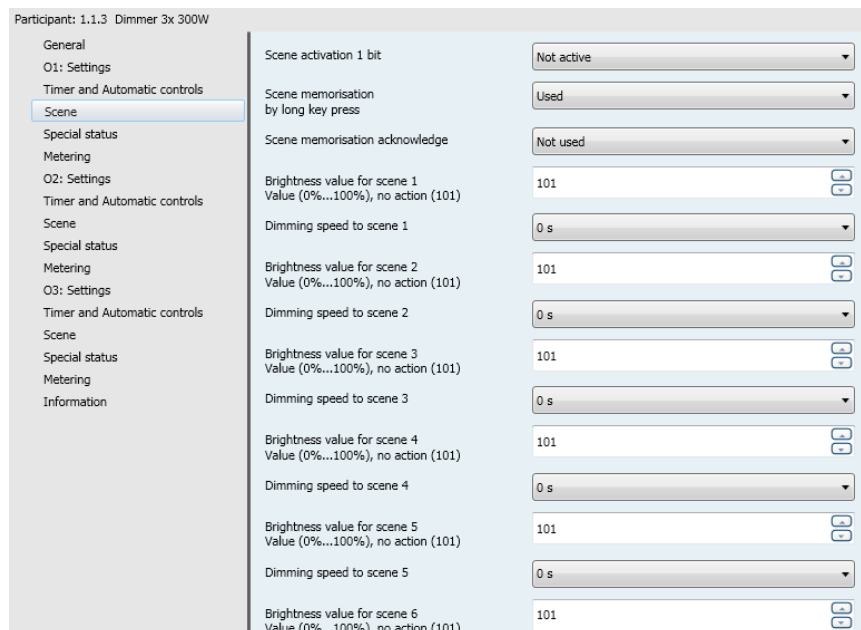

Screen 4

Designation	Description	Values
Scene storing	This parameter authorizes or forbids scene storing.	Used, Not used Default value: Used
Scene memorisation acknowledge*	This parameter activates or deactivates inversion of the status of the output indicating memorisation.	Used, Not used Default value: Used
Lighting value of the scene X	This parameter defines the status of the output associated to scene X.	From 0% to 100% in intervals of 1%, 101 (Do nothing) Default value: 101 (Do nothing)
Dimming speed to scene X	This parameter defines the dimming speed to achieve the lighting level applied for scene X.	0 s, 1 s, 2 s, 3 s, 4 s, 5 s, 10 s, 15 s, 20 s, 30 s, 45 s, 1 min, 2 min, 3 min, 4 min, 5 min, 10 min, 15 min, 20 min, 30 min, 45 min, 1 h, 1 h 30 min, 2 h, 2 h 30 min, 3 h, 3 h 30 min, 4 h Default value: 0 s
Scene activation 1 bit	This parameter allows 2 of the 32 possible scenes to be activated, with the help of the Scene 1 bit object.	Not active, Active Default value: Not active
Scene A activation** (0) Scene B activation** (1)	When the parameter Scene activation 1 bit has the value Active, the parameters Scene activation A and Scene activation B must be set. These parameters define the scenes to be activated for the two values of the Scene 1 bit object.	No active scene, Scene 1 to Scene 32 Default value: No active scene

* This parameter is only visible if the **Scenes memorisation** parameter is activated.

** These parameters are only visible if the **Activation scene 1 bit** parameter has the value: Active.

B. Learning and storing in the room

This procedure modifies and stores a scene by local action on the push buttons located in the room:

- Activate the scene by pressing briefly on the room push button that triggers the scene,
- Set the outputs to the desired status using the push buttons that control them individually,
- Store the output statuses by pressing the room push button that triggers the scene for longer than 5 s.

Storage is indicated by the inversion of the status of the outputs concerned for 3s.

C. Learning and storing on the product

This procedure allows modifying and storing a scene by means of local action on the push buttons located on the front side of the products. This procedure also allows an output to be removed from a scene (Not involved).

- Activate the scene by pressing briefly on the room push button that triggers the scene,
- Store the output statuses by pressing the room push button that triggers the scene for longer than 5 s, The storage is indicated by the status inversion of the involved outputs for 3 sec.
- As soon as the indicators associated with the outputs blink slowly, press briefly and repeatedly the push buttons linked with the outputs to set the outputs to the desired status. The indicators associated with the outputs show the status chosen:
 - Off if the value selected for the scene is 0%,
 - Permanent red if the value selected for the scene is greater than or equal to 1%,
 - Red and quickly blinking if the value selected for the scene is Not involved.
- Store the status selected for this scene pressing for a time longer than 3 sec the push button associated with the output. The storage is indicated by the return of the slow blinking of the indicators associated with the outputs.
- Repeat the previous step for each of the outputs of the scene.

■ Timer and Automatic controls functions

The Timer and Automatic controls function allow the outputs to be controlled by:

- The time delay functions: Timer / toggle switch change over, Timer, Switching delay, Tripping delay, Switching and tripping delay,
- The automatic controls functions: Authorization, AND or OR logical combinations,
- Parameters: The status of the output depends on the combination of the parameters **Type of automatic control** and **Control type**.

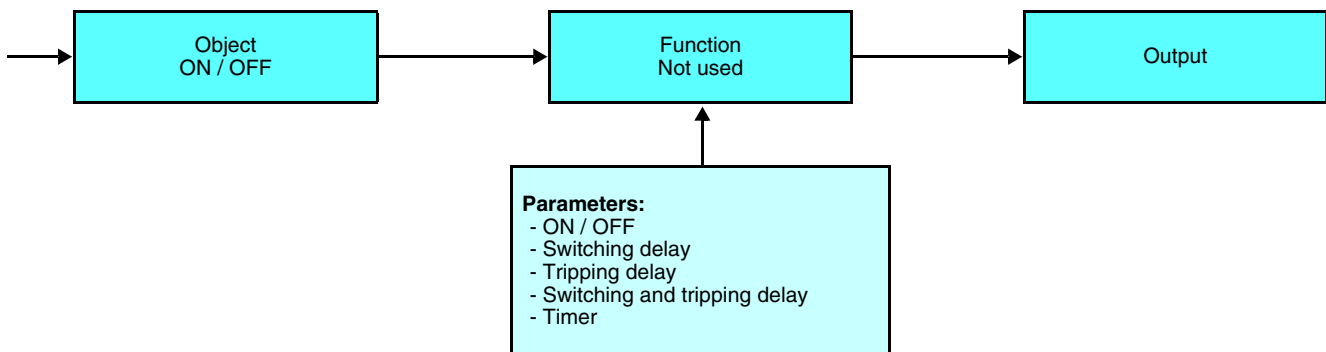

Parameter Setting screen: See Screen

Automatism type	Control type	Operation	Parameter
Not used (Default value)	ON / OFF (Default value)	The output is controlled directly. The Automatic control object is ignored.	
	Switching delay	The output is delayed when switching. The Automatic control object is ignored.	Switching delay: [0.5 s - 24 h]* Default value: 3 min
	Tripping delay	The output is delayed when tripping. The Automatic control object is ignored.	Tripping delay: [0.5 s - 24 h]* Default value: 3 min
	Switching and tripping delay	The output is delayed when switching and when tripping. The Automatic control object is ignored. The switching and tripping delay times may be different.	Switching delay: [0.5 s - 24 h]* Default value: 3 min
			Tripping delay: [0.5 s - 24 h]* Default value: 3 min
Timer	The output is delayed at ON or at OFF. The Automatic control object is ignored.	Time switch delay: [0.5 s - 24 h]* Default value: 3 min Timer operation: ON, OFF Default value: ON	

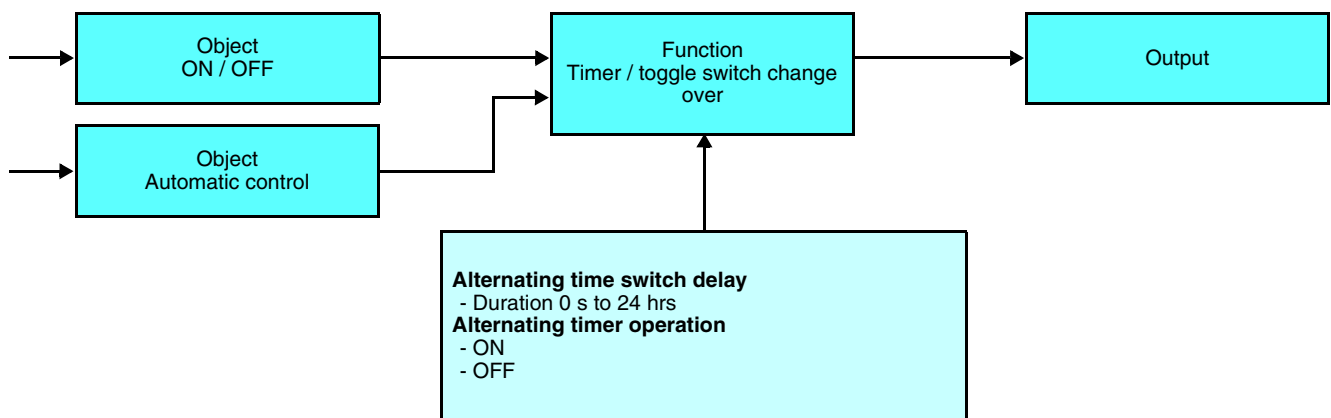

Parameter Setting screen: See Screen

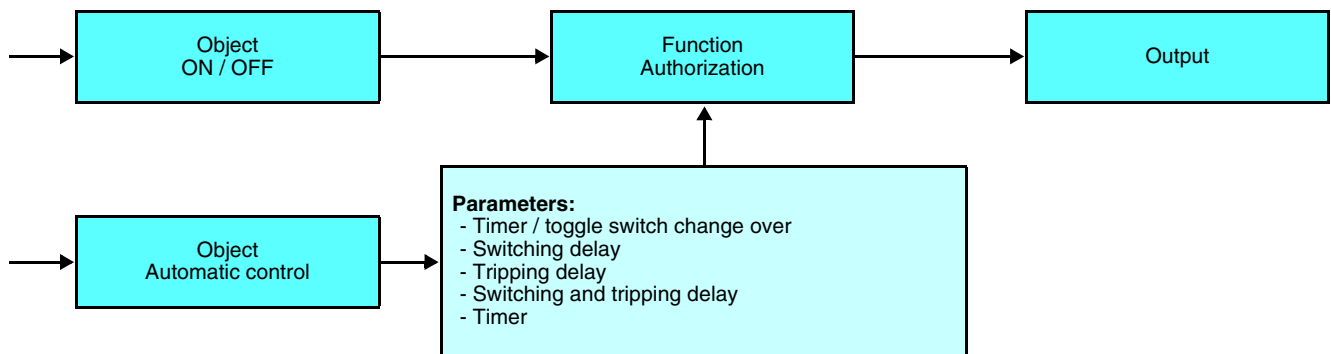

Automatism type	Control type	Operation	Parameter
Authorization	Timer / toggle switch change over	The output is controlled directly by the ON / OFF object if the value of the Automatic control object is 1. The output is delayed at ON or at OFF if the value of the Automatic control object is 0.	Time switch delay: [0 s - 24 h]* Default value: 3 min Time switch delay: ON, OFF Default value: ON
	Switching delay	The output is delayed when switching if the value of the Automatic control object is 1. The commands are not taken into consideration if the value of the Automatic control object is 0.	Switching delay: [0.5 s - 24 h]* Default value: 3 min
	Tripping delay	The output is delayed when tripping if the value of the Automatic control object is 1. The commands are not taken into consideration if the value of the Automatic control object is 0.	Tripping delay: [0.5 s - 24 h]* Default value: 3 min
	Switching and tripping delay	The output is delayed when switching and when tripping if the value of the Automatic control object is 1. The commands are not taken into consideration if the value of the Automatic control object is 0.	Switching delay: [0.5 s - 24 h]* Default value: 3 min Tripping delay: [0.5 s - 24 h]* Default value: 3 min
	Timer	The output is delayed if the value of the Automatic control object is 1. The commands are not taken into consideration if the value of the Automatic control object is 0.	Time switch delay: [0 s - 24 h]** Default value: 3 min Timer operation: ON, OFF Default value: ON

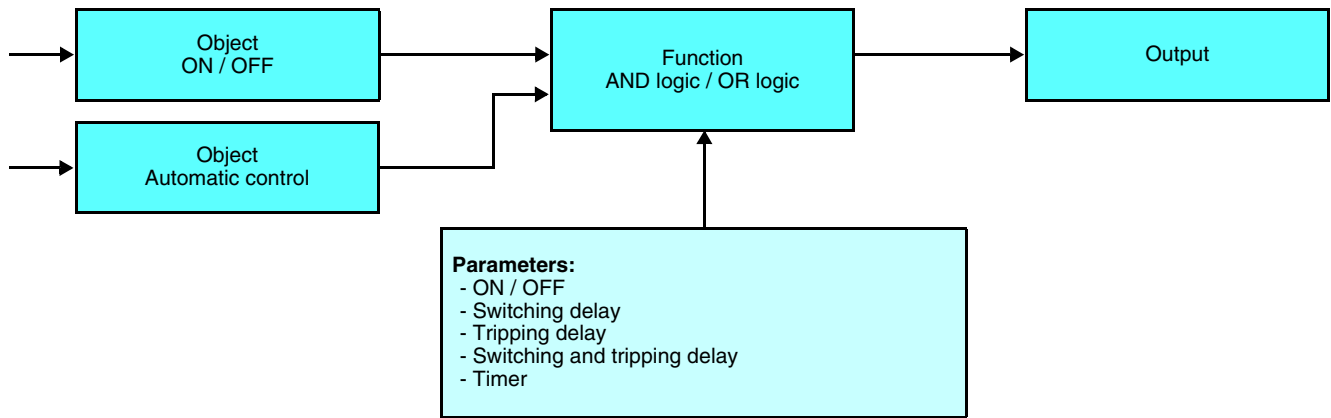

Automatism type	Control type	Operation	Parameter
AND logic	ON / OFF	The output is the result of the AND logic between the value of the ON / OFF object and the value of the Automatic control object.	
	Switching delay	The output is the result of the AND logic between the value of the ON / OFF object delayed when switching and the value of the Automatic control object.	Switching delay: [0.5 s - 24 h]* Default value: 3 min
	Tripping delay	The output is the result of the AND logic between the value of the ON / OFF logic delayed when switching and the value of the Automatic control object.	Tripping delay: [0.5 s - 24 h]* Default value: 3 min
	Switching and tripping delay	The output is the result of the logical AND between the value of the ON / OFF object delayed when switching and when tripping, and the value of the Automatic control object.	Switching delay: [0.5 s - 24 h]* Default value: 3 min Tripping delay: [0.5 s - 24 h]* Default value: 3 min
	Timer	The output is the result of the AND logic between the value of the ON / OFF delayed object and the value of the Automatic control object.	Time switch delay: [0 s - 24 h]** Default value: 3 min Timer operation: ON, OFF Default value: ON

Automatism type	Control type	Operation	Parameter
OR logicOR	ON / OFF	The output is the result of the OR logic between the value of the ON / OFF object and the value of the Automatic control object.	
	Switching delay	The output is the result of the OR logic between the value of the ON / OFF object delayed when switching and the value of the Automatic control object.	Switching delay: [0.5 s - 24 h]* Default value: 3 min
	Tripping delay	The output is the result of the OR logic between the value of the ON / OFF object delayed when tripping and the value of the Automatic control object.	Tripping delay: [0.5 s - 24 h]* Default value: 3 min
	Switching and tripping delay	The output is the result of the OR logic between the ON / OFF object delayed when switching and tripping and the value of the Automatic control object.	Switching delay: [0.5 s - 24 h]* Default value: 3 min Tripping delay: [0.5 s - 24 h]* Default value: 3 min
	Timer	The output is the result of the OR logic between the value of the ON / OFF delayed object and the value of the Automatic control object.	Time switch delay: [0 s - 24 h]** Default value: 3 min Timer operation: ON, OFF Default value: ON

* Setting range [0.5 s - 24 h]

0.5 s, 1 s, 2 s, 3 s, 5 s, 10 s, 15 s, 20 s, 30 s, 40 s, 45 s, 50 s, 1 min, 1 min 15 s, 1 min 30 s, 2 min, 2 min 30 s, 3 min, 4 min, 5 min, 6 min, 7 min, 8 min, 9 min, 10 min, 11 min, 12 min, 13 min, 14 min, 15 min, 20 min, 30 min, 40 min, 50 min, 1 h, 1 h 30 min, 2 h, 2 h 30 min, 3 h, 3 h 30 min, 4 h, 5 h, 6 h, 12 h, 24 h.

** Setting range [0 s - 24 h]

0 s, 0.5 s, 1 s, 2 s, 3 s, 5 s, 10 s, 15 s, 20 s, 30 s, 40 s, 45 s, 50 s, 1 min, 1 min 15 s, 1 min 30 s, 2 min, 2 min 30 s, 3 min, 4 min, 5 min, 6 min, 7 min, 8 min, 9 min, 10 min, 11 min, 12 min, 13 min, 14 min, 15 min, 20 min, 30 min, 40 min, 50 min, 1 h, 1 h 30 min, 2 h, 2 h 30 min, 3 h, 3 h 30 min, 4 h, 5 h, 6 h, 12 h, 24 h.

■ Special status

The settings covered in this section make it possible to define the behaviour of the outputs in certain specific cases.

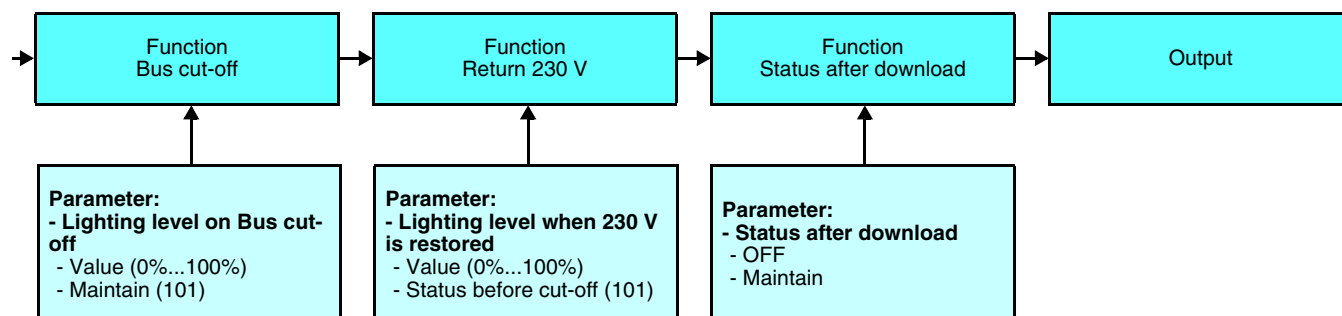

Parameter Setting screen: See Screen

Designation	Description	Values
Lighting level on Bus cut-off	This parameter defines the lighting level applied when the bus is restored.	From 0% to 100% in intervals of 1%, 101 (Maintain) Default value: 101 (Maintain)
Lighting level when 230 V is restored	This parameter defines the lighting level applied when the 230 V is restored.	From 1% to 100% in intervals of 1%, 101 (Status before cut-off) Default value: 101 (Status before cut-off)
Status after download	This parameter defines the status of the output applied after a download.	OFF, Maintain Default value: Maintain

■ Metering function

The Metering function is used to measure the total duration of an output at ON or at OFF. The duration is transmitted by the **Metering** object. A set-point triggering an alarm may be programmed. The alarm is transmitted by the **Counter set point reached** object. The current measurement can be consulted at any time using the **Meter** object.

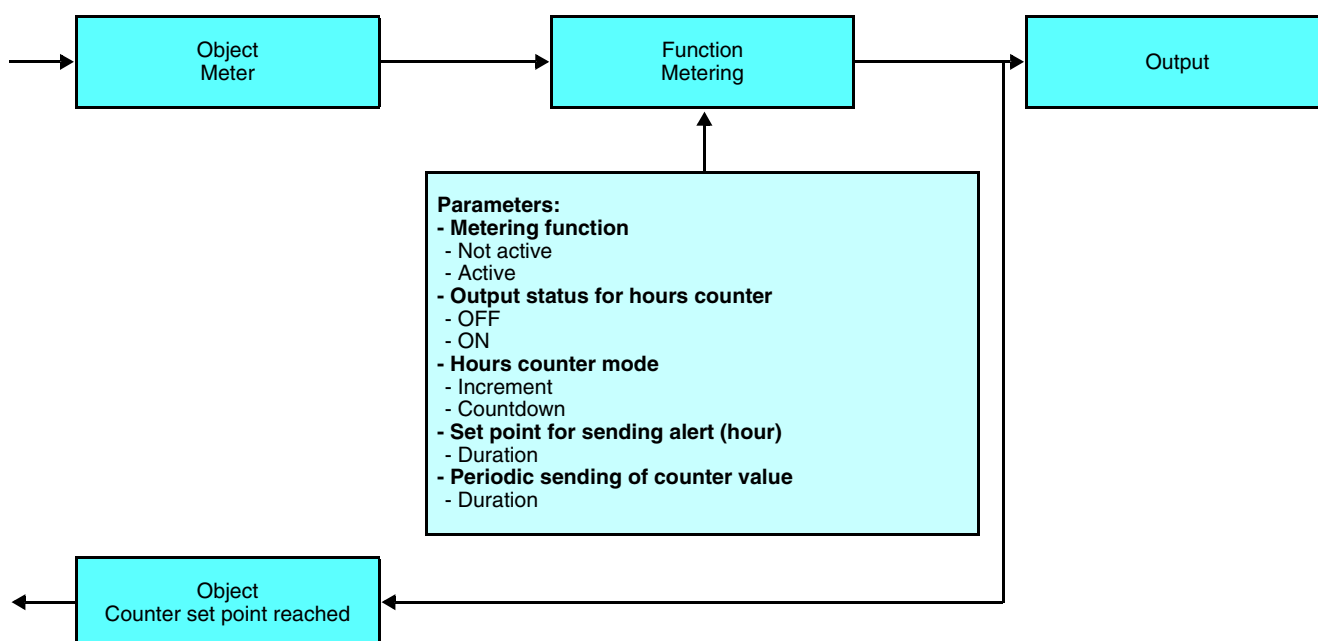

Parameter Setting screen:

Designation	Description	Values
Metering function	This parameter allows activating the Counter function. The value of the counter can be read through the Hours counter object.	Not active, Active Default value: Not active
Output status for hours counter*	This parameter allows choosing the status of which the cumulated time is measured.	OFF, ON Default value: ON
Hours counter mode*	This parameter is used to define the Hours counter mode.	Increment, Countdown Default value: Increment
Set point for sending alert (hour)*	This parameter defines an alarm set-point for which the Counter set-point reached object will be sent.	From 0 to 50000 hours with 1-hour steps Remark: The Counter set-point reached object may be reset either by a new download or by means of a display tool. Default value: 1000

* This parameter is only visible if the **Counter function** parameter has following value: Active.

3. Main characteristics

Product	TXA210N TXA210AN	TXA213N
Max. number of group addresses	254	254
Max. number of links	255	255
Objects	19 17	53 17

4. Physical addressing

To perform physical addressing or check the presence of the bus, press the lighted push button located above the label holder on the right of the product.

Programming LED ON = Bus present and the product is in programming mode.

The product remains in programming mode until the physical address has been transmitted by ETS. Press again to exit programming mode.

Physical addressing can be performed in Auto or Manu mode .

