

Meter Kit Instructions

Instruction leaflet for fitting 250A Meter Pack

Meter to be fitted when fitting incomer (see incomer instructions).
Incomer shown in place for illustration purposes.

JK240PM - JK240MID

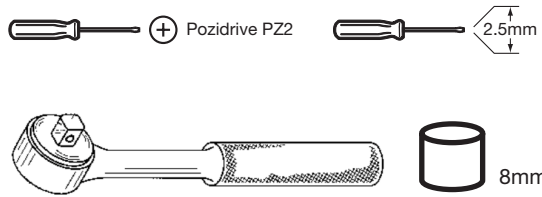

ZD0882

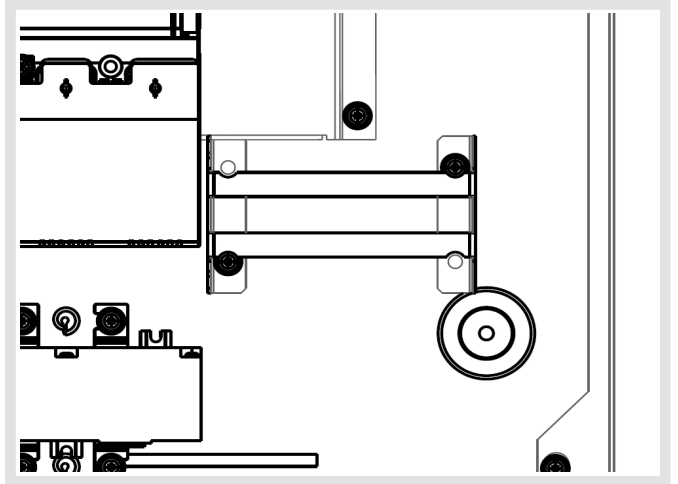
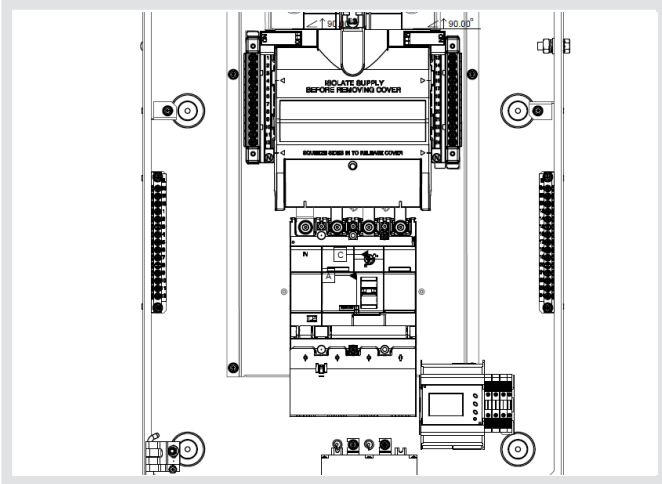

Meter installation position bottom right of the 250A TPN board, if to aperture in the bottom right hand corner please use the din rail provided to mount underneath the incomer molding and cut out where applicable and follow the phase connections below - CT fixings remain the same.

Install Meter bracket in the bottom right hand corner using the 2 off hex head high torque screws provided.
Fit the feet to the Current transformer x 4 whilst taking care of the direction of the CT, there is an arrow on the side to show the direction and secure with the 4 off hex head high torque screws.

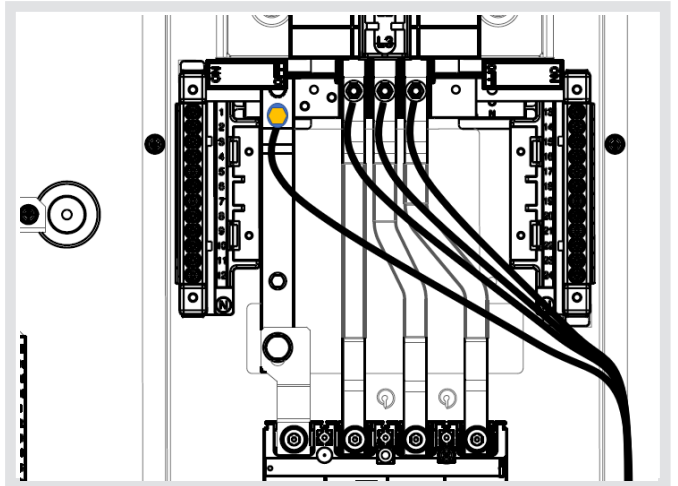
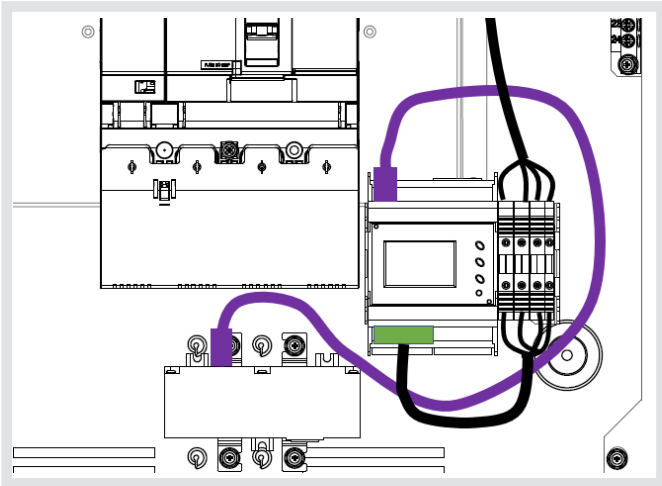

Fit the meter and fuses L3/L2/L1/N as shown above by clipping to the bracket.
Plug in the RJ45 cables to the Meter and CT if using the MID version you may now use a wire seal to seal up the connection on the CT using the plastic clip provided and seal the clear shroud to the meter housing preventing the removal of the RJ45 Cables.

Finally connect the phase cables and neutral to the positions pictured above L1 - L2 - L3 & Neutral with the carp nuts provided and torque to 5Nm.

Hager Technical Service Centre: 01952 675 689
Hager Technical Fax: 01952 675 557

Hager Sales Service Centre: 01952 675612

Website: www.hager.co.uk
E-mail us: technical@hager.co.uk
Twitter: @hageruk



ZD0882