

Manual

Fire-resistant wall mounting door

for 30 min. with exposure to fire from the inside



FB51WLN
FB52WLN
FB53WLN
FB61WLN

FB62WLN
FB63WLN
FB64WLN
FB71WLN

FB72WLN
FB73WLN
FB74WLN
FB75WLN

FB81WLN
FB82WLN
FB83WLN
FB84WLN

Version 1.3



Transport/Storage/Assembly/Commissioning/Maintenance

NB:

It is imperative that you read the manual prior to commissioning for the first time. Please observe the safety information.





Serial number: _____

to be completed after delivery

Table of Contents

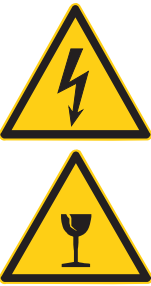
1	Contents	3
2	Safety information	4
2.1	Manufacturer's declaration	5
3	Transport and storage	5
3.1	Basic information on handling the housing with care	5
4	About this manual	6
4.1	Information on manual layout	6
5	Abbreviations and terms	7
	Fire-resistance rating	7
	Maintenance of performance	7
	DIN 4102	7
	MBO (model building regulation)	8
	MLAR (pipe supply regulation draft)	8
	Wall mounting door	8
6	Performance description	9
6.1	Designated use	9
6.2	Technical data	9
7	Device description	10
7.1	Scope of supply	10
7.2	Screw connections	11
7.3	Primary elements	13
7.4	Dimensions	14
8	Mounting	15
8.1	Fitting the wall mounting door (single- and double-leaf version)	17
9	Commissioning	22
10	Maintenance and repair	23
10.1	What to do after a fire	23
11	Technical documents	24
11.1	General building inspectorate approval	24
11.2	EU Declaration of Conformity	24
11.3	Forms and templates	25
	Info note on delivery after transport	25
	Maintenance checklist	26
12	Imprint/Contact	28

2 Safety information

	<p style="text-align: center;">⚠ WARNING</p> <p>Untrained personnel can not mount the housing safely or in line with standards.</p> <p>→ Risk of an electric shock</p> <p>→ Impaired fire safety effectiveness</p> <ul style="list-style-type: none"> ▶ Have the housing handled by a qualified electrician. ▶ Have operating personnel instructed professionally and correctly. ▶ Ensure that operating personnel fully understand their tasks and activities and have them supervised by a qualified electrician.
	<p style="text-align: center;">⚠ WARNING</p> <p>The insulating materials in the housing react sensitively to external factors.</p> <p>→ Impaired fire safety effectiveness</p> <ul style="list-style-type: none"> ▶ Ensure that the housing does not display any damage (cracks, displaced insulation etc.). ▶ Only use the housing when it is in a safe and technically perfect condition. ⊘ Never mount the housing outside. ⊘ No dusty or vibrating environments. ⊘ Do not mount the housing in rooms with temperatures below 10° C or over 40° C. ⊘ Do not store or mount the housing in rooms with air humidity exceeding 50 %.
	<p style="text-align: center;">⚠ WARNING</p> <p>Doors/Flaps left open</p> <p>→ Impaired fire safety effectiveness</p> <ul style="list-style-type: none"> ▶ Always close the housing when it is in operation ▶ Minimise periods of access to the housing interior.
	<p style="text-align: center;">⚠ CAUTION</p> <p>If the manual is missing</p> <p>→ Non-designated handling of the housing</p> <ul style="list-style-type: none"> ▶ Always leave the manual inside the housing or within the reach of operating personnel.
	<p style="text-align: center;">⚠ CAUTION</p> <p>If the fire safety system is not planned in conformity with the law</p> <p>→ Attenuation of the fire safety effectiveness of the overall system</p> <ul style="list-style-type: none"> ▶ Please observe the MLAR, the respective LAR applicable in your country, the VDE regulations, the DIN, the general building inspectorate approval and the stipulations of the fire safety authorities and building supervisory authorities (see section 5).

2.1 Manufacturer's declaration



No liability is accepted for formulation or printing errors.

Modifications made by the customer to the design and/or housing will lead to the loss of certification and will release Hager Electro GmbH & Co. KG from any claims for compensation or recourse.

The manufacturer retains the right to make technical and structural modifications.

3 Transport and storage

When you accept the fire protection housing, please observe the enclosed Info note on delivery after transport. Information is also available in section 11.3 of this manual.

	 WARNING
	<p>The housing can incur damage during transport and storage.</p> <p>→ Impaired fire safety effectiveness</p> <p>▶ Please follow the basic information on handling the housing with care (see below).</p>

3.1 Basic information on handling the housing with care

- ▶ If possible, transport the housing in the packaging supplied (possibly also on a transport pallet).
- ▶ Do not release the ties until the installation location is reached.
- ▶ Store and mount the housing on a firm, level and clean surface only.
- ▶ Only lay the housing on its back or side without jerking and in full; keep the door(s)/flap closed.
- ▶ Protect the housing from moisture, rain, splashwater and external weather conditions.
- ▶ Leave the housing in its packaging during interim storage.
- ▶ The suitability of screws/anchors depends on the building and must be examined in advance.
- ⊙ Do **not** store the housing in rooms with temperatures below 10 °C or over 40 °C.
- ⊙ Do **not** store the housing in rooms with air humidity exceeding 50%.
- ⊙ Do **not** expose the housing to frost. Do not stack.
- ⊙ Do **not** load.
- ⊙ **Avoid** hard impact, multiple reloading and one-sided loads when setting up.

4 About this manual

This manual is aligned towards qualified personnel entrusted with the transport, storage, installation, commissioning and maintenance of the wall mounting door. The manual aims to help you to carry out these tasks safely to ensure that the housing is always capable of fully complying with its functions.

Please read the manual carefully before handling the wall mounting door in any way. It is also imperative that you note the information on transport and storage (section 3) as it is important for the fire safety function that the distribution is handled correctly from the moment of delivery.

The manual must always be kept in the housing or within the reach of operating personnel.

4.1 Information on manual layout

This manual displays a consistent layout which aims to help you to swiftly find the requisite information and clearly identify the type of information supplier (general information, operating instructions, sources of danger etc.).

A result is indicated by an arrow:

→ **This is the result of an action or situation.**

Operating instructions are indicated by an arrowhead:

▶ 1. Please follow these instructions.

Instructions to be followed step-by-step are numbered consecutively.



A ban is indicated by the prohibition sign:

⊘ Do **not** do the following.

If additional tools or other items are required, they are indicated by a ring:

○ This is required.

To enable you to identify safety information as such, it is depicted in a box similar to the following.

	 CAUTION
	Type and source of danger → Possible consequences ▶ Measures or ⊘ prohibitions

A safety symbol in the left-hand column enables you to immediately classify the type of danger involved; a risk of fracture is symbolised in this example.

The headline in the hazard warning contains a triangle with an exclamation mark (the safety symbol for a general hazard area) followed by **CAUTION** or **WARNING**.

CAUTION for information which can lead to minor injury if ignored.

WARNING for information which can lead to death or serious, long-term injury if ignored.

WARNING

The headline is then followed by a description of the type and source of danger.

The → symbol indicates the possible negative consequences.

And depending on the situation, this is followed by the measures to be taken (▶), or information regarding prohibited measures (⊘).

5 Abbreviations and terms

Fire-resistance rating

The fire-resistance rating is the period of time which a component retains its cold properties (load-bearing, room-enclosing) during testing based on DIN 4102, Part 2.

Maintenance of performance

Maintenance of performance concerns maintaining a property or condition in the event of a fire (e.g. power supply for systems of safety relevance). To enable the installer to assess whether the system retains its function in the event of a fire, Hager provides the relevant parameters from the fire tests on the housing on request.

DIN 4102

The DIN 4102 standard defines the combustibility of building materials and the fire resistance of components. It is the classic standard governing building regulations which outlines how the structural fire safety specified by the building regulations is to be realised. It makes examination of fire performance compulsory by means of standard testing.

Until such a time as a test standard is available for distribution functions, they are tested by manufacturers on the basis of DIN 4102, Parts 2 and 12.

Typical fire-resistance classes (some are also referred to as fire safety classes) in accordance with DIN 4102 are:

- Fire-resistance rating F0: The component complies with its function for less than 30 minutes in the event of a fire.
- Fire-resistance rating F30: The component complies with its function for at least 30 minutes in the event of a fire. This roughly corresponds with the following building inspectorate term: fire-retardant.
- Fire-resistance rating F60: The component complies with its function for at least 60 minutes in the event of a fire. This roughly corresponds with the following building inspectorate term: highly fire-retardant.
- Fire-resistance rating F90: The component complies with its function for at least 90 minutes in the event of a fire. This roughly corresponds with the following building inspectorate term: fire-resistant.

- Fire-resistance rating F120: The component complies with its function for at least 120 minutes in the event of a fire. This roughly corresponds with the following building inspectorate term: highly fire-resistant.
- Fire-resistance rating F180: The component complies with its function for at least 180 minutes in the event of a fire. This roughly corresponds with the following building inspectorate term: extremely fire-resistant.

MBO (model building regulation)

Building fire safety for standard buildings is essentially regulated in Germany by the MBO, whereby § 14 must be observed in particular (version dated November 2002):

§ 14 Fire protection

Structural systems must be arranged, constructed, modified and maintained in such a way that the outbreak of fire and the spreading of fire and smoke (fire propagation) are prevented and the rescue of people and animals as well as effective fire extinguishing is possible in the event of a fire.

The state building regulations (LBO) shall apply as implementations of the MBO in the individual federal states.

MLAR (pipe supply regulation draft)

The MLAR outlines the technical fire protection requirements on piping systems in all types of buildings. The updated MLAR 11/2005 has already been introduced in many federal states or must be taken into consideration as the “state of the art”. It replaces the MLAR 03/2000.

The MLAR is implemented at state level in the form of piping system guidelines (LAR) and guidelines governing technical fire protection requirements on piping systems (MLAE, e. g. Bavaria and Saxony).

The MLAR 11/2005 applies for

- a) Piping systems in necessary stairwells, in rooms between stairwells and exits to outdoor areas, in necessary corridors with the exception of open corridors against outer walls,
- b) the installation of lines through room-enclosing components (walls and ceilings),
- c) the function of electric line systems in the event of a fire.

Wall mounting door

The products with order numbers FB51WLN, FB52WLN, FB53WLN, FB61WLN, FB62WLN, FB63WLN, FB64WLN, FB71WLN, FB72WLN, FB73WLN, FB74WLN, FB75WLN, FB81WLN, FB82WLN, FB83WLN and FB84WLN are summarised here under the term “Wall mounting door”. The terms “fire-resistant wall mounting door” and the more general terms “fire protection distribution”, “fire protection housing” and “housing” are used with the same meaning here.

6 Performance description

6.1 Designated use

The fire-resistant wall mounting door exclusively serves towards spatially safe segregation of switching systems and installations in flush-mounted housings from adjacent corridors, stairwells and workspaces.

Transport, storage, installation, commissioning and maintenance of the fire-resistant wall mounting door may only be carried out by qualified personnel.

The wall mounting door may not be mounted in rooms in which the technical fire safety requirement of the MLAR or state-specific implementation thereof demands a higher fire rating.

6.2 Technical data

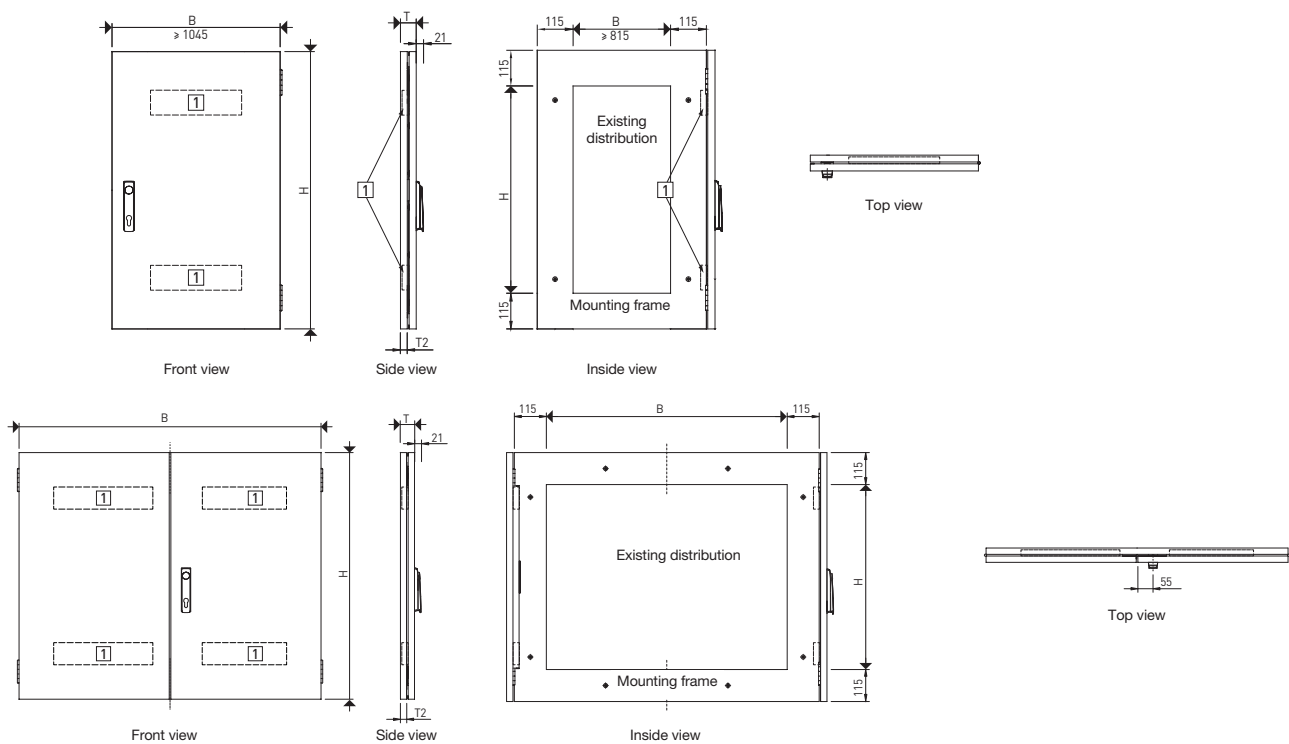

	Exterior			Interior		
	Height (H)	Width (W)	Depth (D)	Height	Width	Depth
FB51WLN	1045	575	51	815	345	0
FB52WLN	1045	795	51	815	565	0
FB53WLN	1045	1045	51	815	815	0
FB61WLN	1195	575	51	965	345	0
FB62WLN	1195	795	51	965	565	0
FB63WLN	1195	1045	51	965	815	0
FB64WLN	1195	1295	51	965	1065	0
FB71WLN	1345	575	51	1115	345	0
FB72WLN	1345	795	51	1115	565	0
FB73WLN	1345	1045	51	1115	815	0
FB74WLN	1345	1295	51	1115	1065	0
FB75WLN	1345	1445	51	1115	250	0
FB81WLN	1495	575	51	1265	345	0
FB82WLN	1495	795	51	1265	565	0
FB83WLN	1495	1045	51	1265	815	0
FB84WLN	1495	1295	51	1265	1065	0

Interior and exterior dimensions

	Weight	Door stop	Doors	Panels
FB51WLN	30 kg	r	1	1
FB52WLN	42 kg	r	1	2
FB53WLN	53 kg	r	1	3
FB61WLN	35 kg	r	1	1
FB62WLN	47 kg	r	1	2
FB63WLN	60 kg	r	1	3
FB64WLN	72 kg	r/l	2	4
FB71WLN	48 kg	r	1	1
FB72WLN	63 kg	r	1	2
FB73WLN	79 kg	r	1	3
FB74WLN	80 kg	r/l	2	4
FB75WLN	118 kg	r/l	2	5
FB81WLN	46 kg	r	1	1
FB82WLN	58 kg	r	1	2
FB83WLN	73 kg	r	1	3
FB84WLN	88 kg	r/l	2	4

Number of panels and doors, weight

- Fire resistance and fire load insulation of 30 minutes
- For Hager univers cabinets
- Turning lever closure prepared for locking cylinder
- Door stop generally on right; on both sides on double doors
- With smoke protection sealing
- Protection rating IP54 (protection against contact, dust deposits on the inside and splashwater from all directions)
- Circumferential adjustable frame with mounting holes
- Detachable door for easy installation
- Fastening materials included
- Safety class II
- Colour similar to RAL 9010, edges are colour-coordinated

Up to 3 additional adjustable frames can be screwed between the door and wall in order to increase the space between the wall and door.

	Exterior Dimensions [mm]			Interior Dimensions [mm]			Weight approx. [kg]
	Height (H)	Width (W)	Depth (D)	Height	Width	Depth	
FZ294N	1045	575	22	815	345	22	11
FZ295N	1045	795	22	815	565	22	13
FZ296N	1045	1045	22	815	815	22	15
FZ297N	1195	575	22	965	345	22	12
FZ298N	1195	795	22	965	565	22	14
FZ299N	1195	1045	22	965	815	22	16
FZ300N	1195	1295	22	965	1065	22	18
FZ307N	1345	575	22	1115	345	22	14
FZ308N	1345	795	22	1115	565	22	16
FZ309N	1345	1045	22	1115	815	22	18
FZ304N	1345	1295	22	1115	1065	22	20
FZ310N	1345	1445	22	1115	1315	22	22
FZ301N	1495	575	22	1265	345	22	15
FZ302N	1495	795	22	1265	565	22	17
FZ303N	1495	1045	22	1265	815	22	19
FZ305N	1495	1295	22	1265	1065	22	21

Adjustable frame

7 Device description

7.1 Scope of supply

Once you have unpacked the wall mounting door, please check the goods supplied for completeness.

The scope of supply includes:

- Supplementary fire door including adjustable frame (adjustable frames for double-leaf distribution doors partially disassembled)
- Push rod locking (already pre-assembled)
- Push rod (already pre-assembled)
- Turning lever (already pre-assembled)
- Sealing compound (cartridge)
- Fastening materials (frame anchors \varnothing 10 mm, incl. screws)
- Number corresponds with the boring holes, only to be used in solid walls.

Optional:

- Additional adjustable frame(s) for concealing projecting distributions by up to 88 mm (single doors) and 66 mm (double doors)
- Lock via square in stainless steel design

7.2 Screw connections:

\varnothing 10 mm, fastening materials (10 mm frame anchors) approved by the building authorities

or

\varnothing 6 mm

e.g.: Würth "ASSY II", \varnothing 6 mm, item no.: 015206xx or 0152016xx, min. length 50 mm (F30), 90 mm (F90)

Anchor length (frame anchors)

= anchoring depth of min. 70 mm + strength of frame

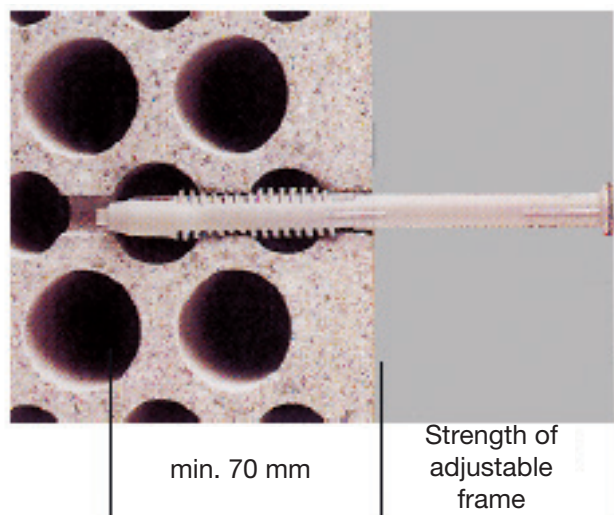

Suitable anchors for the masonry must be selected depending on the type of stone used (solid or perforated blocks) as well as the various materials such as bricks, sand-lime bricks or normal, lightweight or aerated concrete.

The anchors supplied by us are suitable for DIN masonry and stone.

Tensile strength tests should be carried out on anchors if the masonry is unknown.

Recommended boring methods:

- Masonry: without impact
- Concrete: with impact

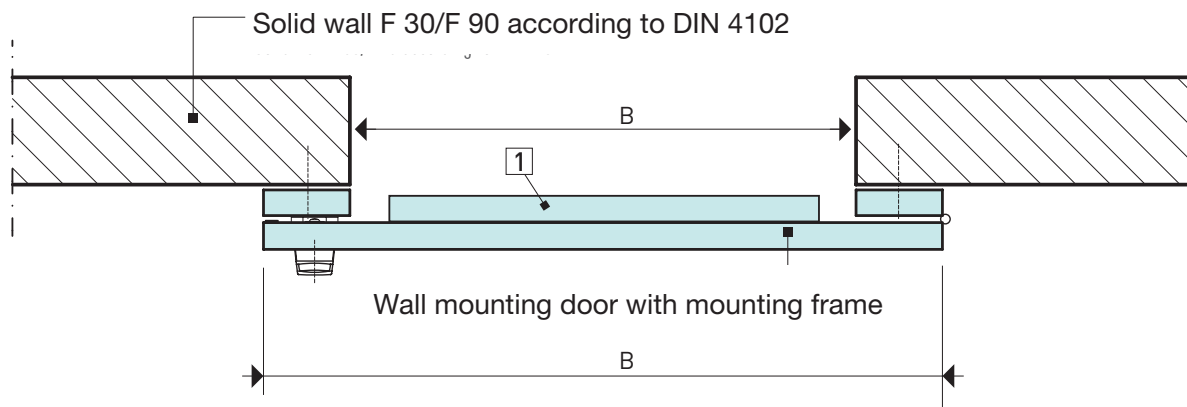

Solid wall

Mounting frame¹ for additional battens

Use up to three mounting frames¹ to increase the wall distance of the revision cover.

	Distance from wall	additional frames		
		1	2	max. 3
1-leaf	0 mm	22 mm	44 mm	66 mm
2-leaf				

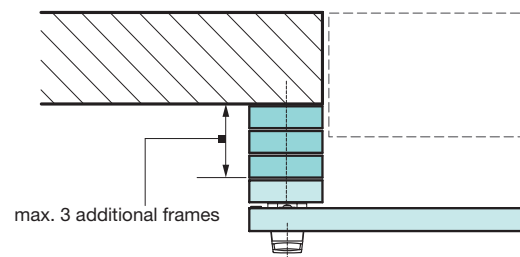

¹ Mounting frame only with test report and manufacturer's declaration of conformity

7.3 Primary elements of the fire door

Single-leaf fire door

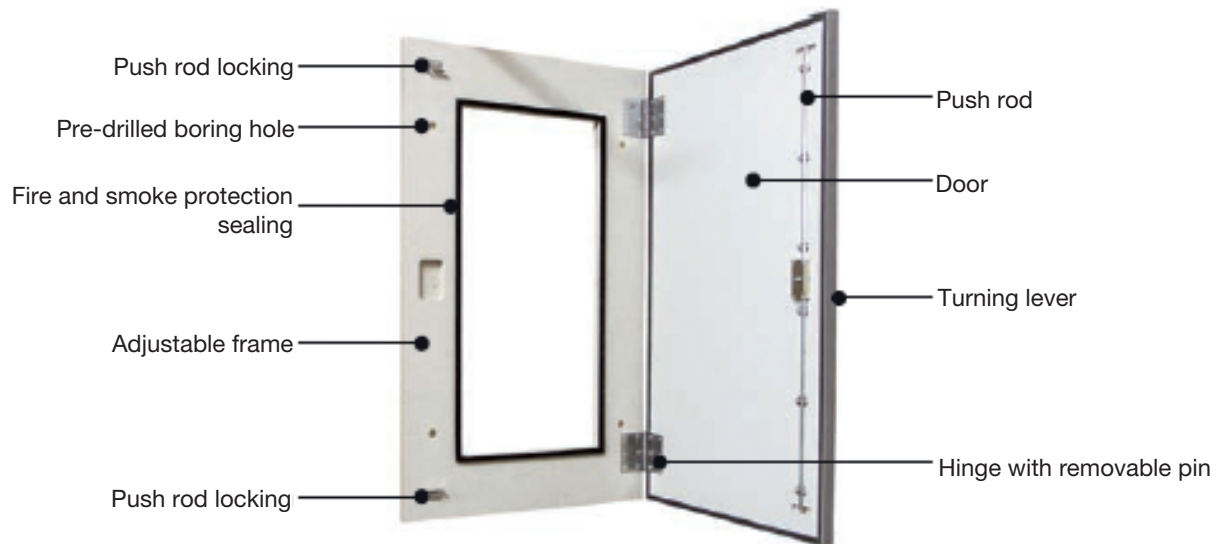

Double-leaf fire door

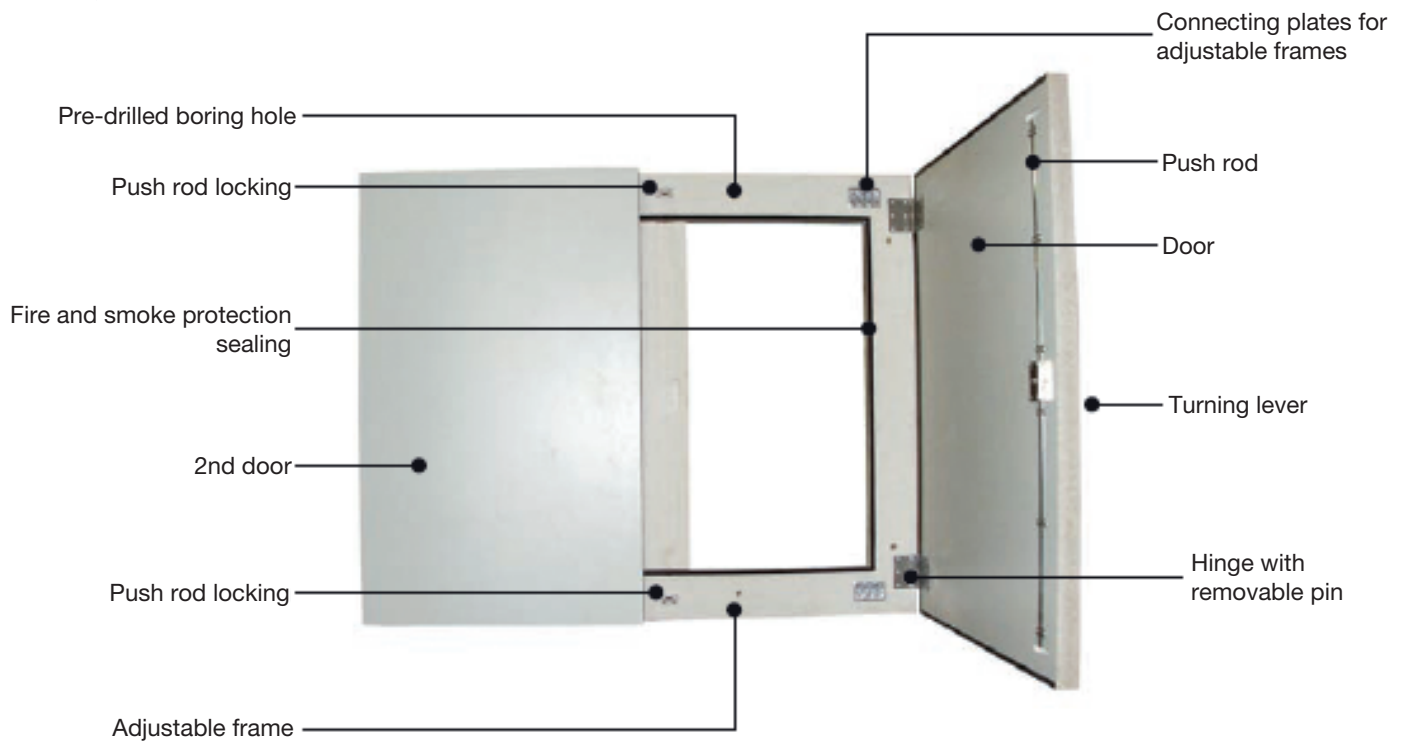

7.4 Dimensions

Example: Double-leaf fire door

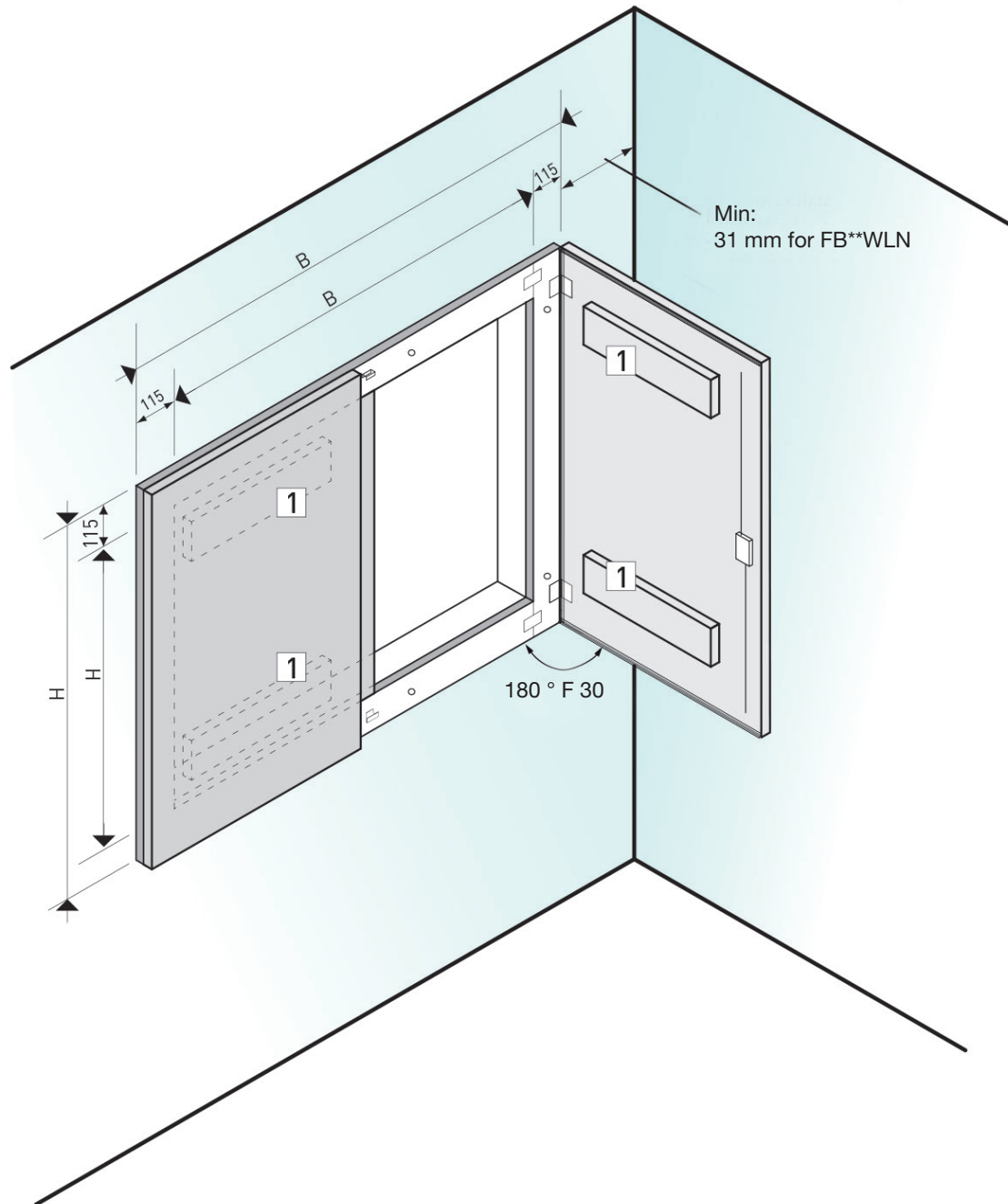

1 Top and bottom moulding on the inside of the door

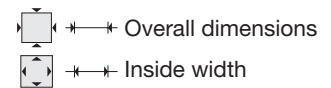





8 Mounting



Some key rules must be observed when mounting the wall mounting door. Please read and follow the safety information as well as observing the safety instructions in section 2.

If a suitable lifting device is not available to raise the wall mounting door to the specified mounting height, there is an alternative mounting possibility: mounting by unscrewing the single/double doors which is outlined in section 8.1.

Only use the anchors and screws supplied for mounting. These mounting materials are only suitable for concrete, solid bricks and solid sand-lime bricks. Where other wall materials are used, please obtain the corresponding approved anchors from a specialist retail outlet. Ensure that they offer a secure hold when combined with the respective wall material and comply with at least the fire resistance displayed by the device.

	<p style="text-align: center;">⚠ WARNING</p> <p>A secure hold by the wall mounting door on the wall can be impaired by many factors.</p> <p>→ Impaired function in the event of a fire</p> <ul style="list-style-type: none"> ▶ Observe the static conditions. ▶ Only mount the door on a wall which displays the fire resistance demanded by the operating conditions of the fire protection housing. ▶ Use fire protection silicone/putty to compensate for any gaps between the wall surface and the wall mounting door. ▶ Use the appropriate anchors and screws. <ul style="list-style-type: none"> ⊘ Do not exert any tension on the housing when securing the screws. ⊘ Do not overload the masonry statics.
	<p style="text-align: center;">⚠ WARNING</p> <p>Damaged screws, hinges or adjustable frames prevent the door elements from being securely mounted.</p> <p>→ Impaired fire safety effectiveness</p> <ul style="list-style-type: none"> ▶ Maximum door opening angle: 180°. ▶ Use a suitable screwdriver. <ul style="list-style-type: none"> ⊘ Do not overtighten the screws. ⊘ Do not use the frame as a boring template. ⊘ Do not bore through the frame or mounting holes.
	<p style="text-align: center;">⚠ WARNING</p> <p>Housings which are not aligned as designated can be subject to severe tension</p> <p>→ Impaired fire safety effectiveness</p> <ul style="list-style-type: none"> ▶ Do not mount the housing sideways or upside down. ▶ Align the housing vertically.
	<p style="text-align: center;">⚠ CAUTION</p> <p>The fire protection housing is bulky</p> <p>→ Risk of crushing hands</p> <ul style="list-style-type: none"> ▶ Use work gloves.

8.1 Fitting the single- and double-leaf version

- Examine the goods for damage. Examine the contents for completeness.
- The hinges, push rod locking, push rod and turning lever are already pre-assembled on the frame or door panel.

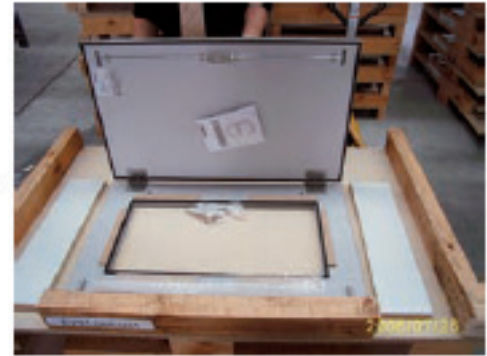

After removing the packaging, do not use the turning lever to open the door or pull it upwards while horizontal. Only use the turning lever to unlock the door and carefully open the door by hand.

For transport reasons, the frame for double-leaf doors is supplied partially disassembled. The following photos illustrate how a frame is assembled. If necessary, detach the doors first to facilitate assembly. Do this by pressing the pin upwards out of the stainless steel hinge before removing the door(s).

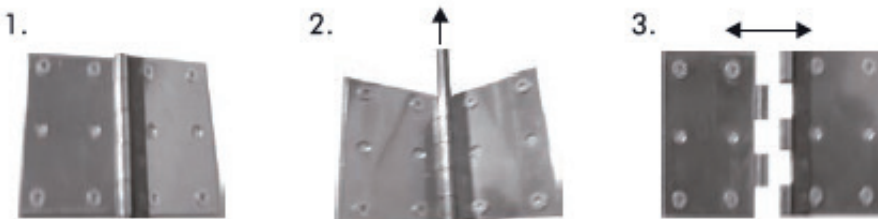

For safety reasons, a second person should help to detach the door panels from the frame (especially in the case of double-leaf door elements).

Push the frame together as depicted in Fig. 1 and secure the connecting plates with the screws supplied (4 screws per frame corner – 2 for each corner and frame section – totalling 16 screws for 4 corners). Please ensure that the seal for the horizontal corner elements is aligned towards the inside opening.

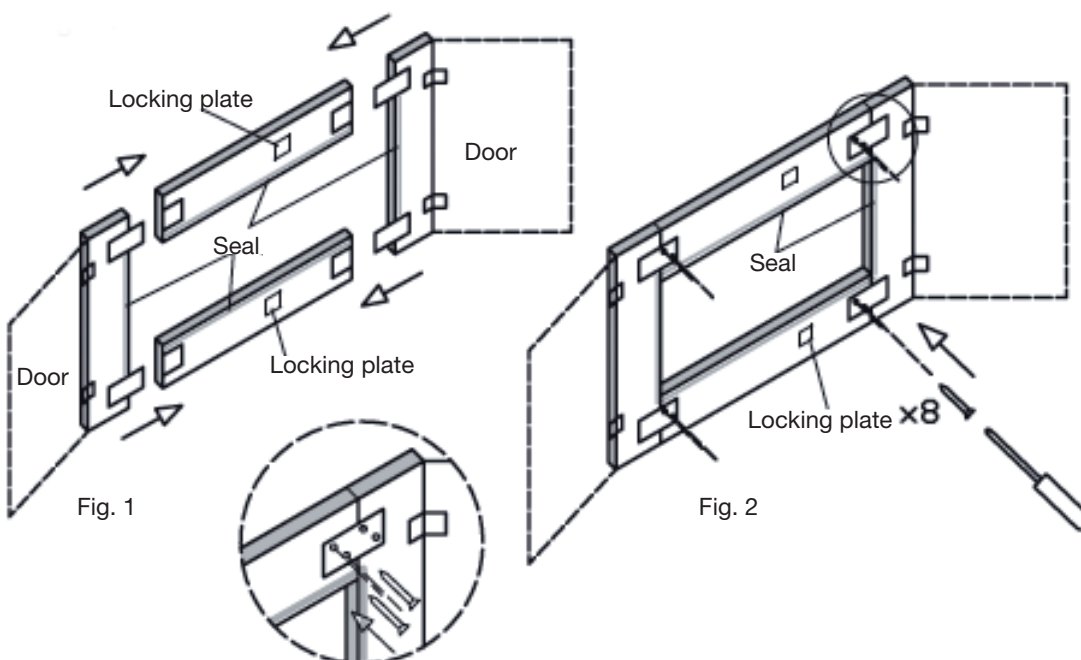

Align the adjustable frame on the wall and mark the boring holes.

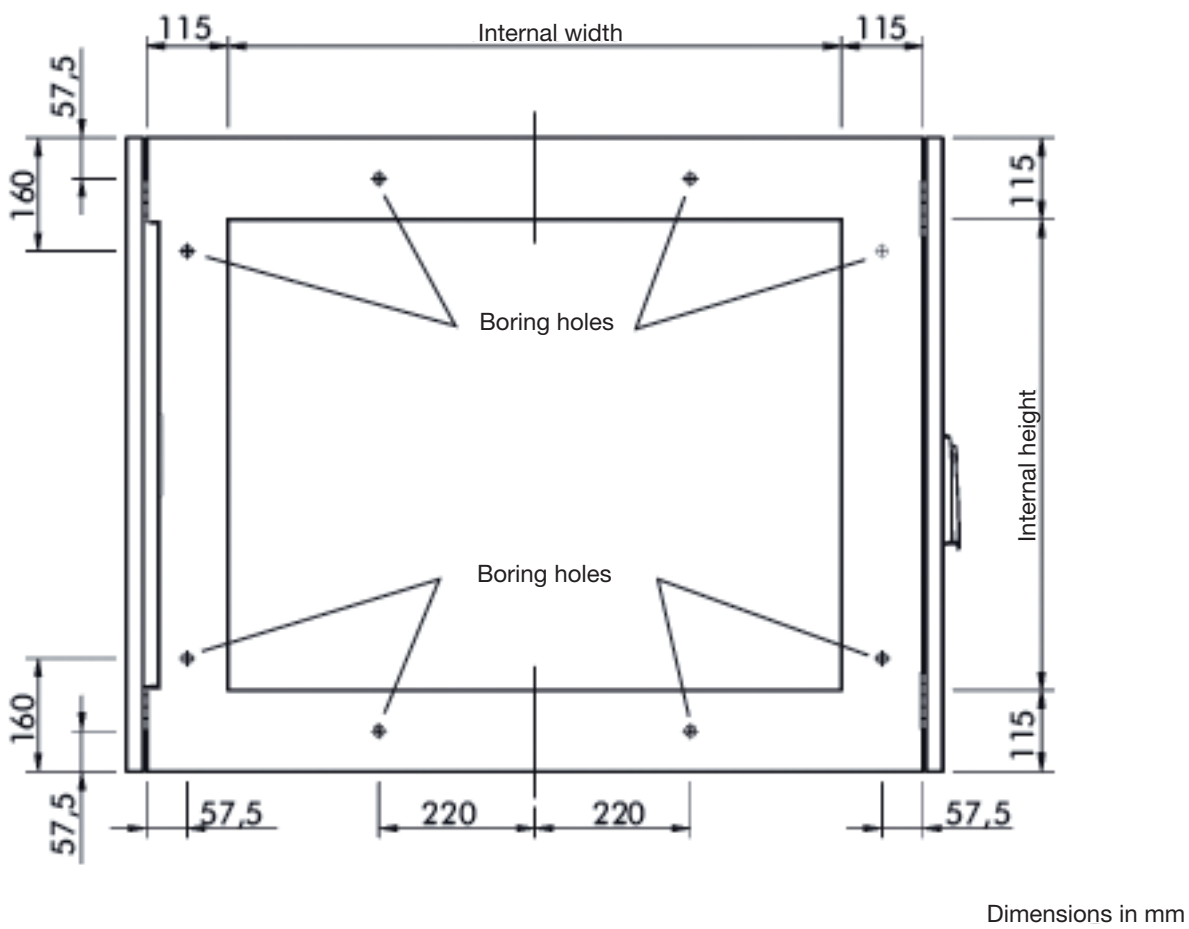
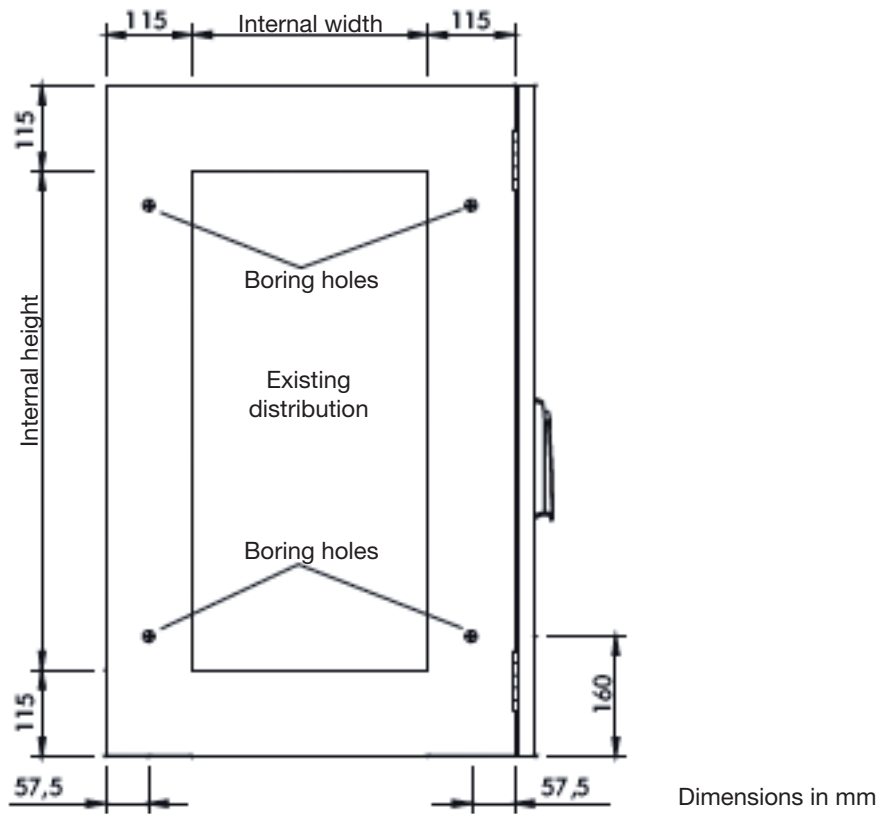

Securing to masonry:

Use a drill with \varnothing 10 mm bit to drill the holes in the wall based on the markings.
Observe an anchoring depth of min. 70 mm in the wall.

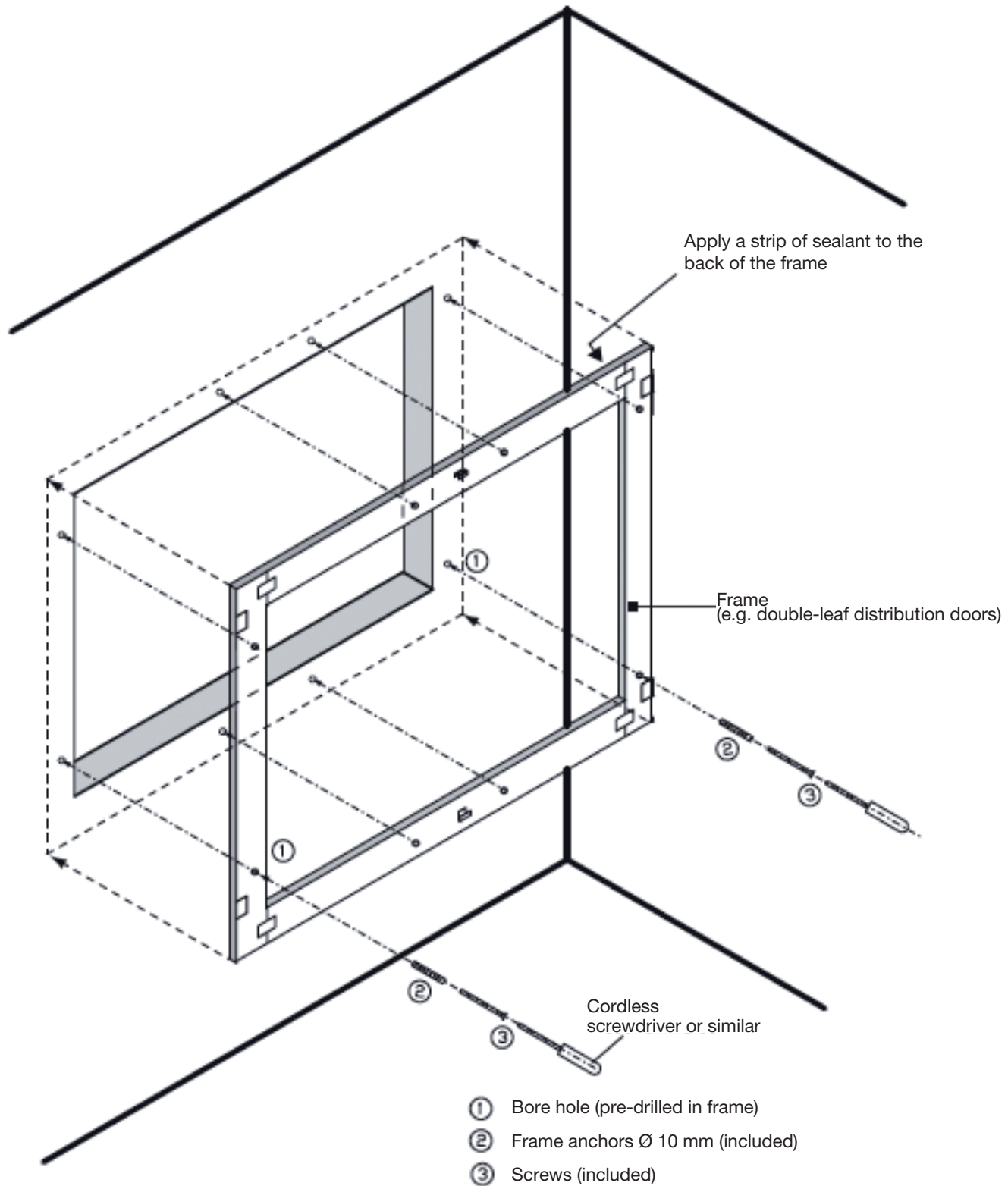

Apply the sealant supplied all around the back of the frame (see Fig.). This enables any irregularities of up to 4 mm to be smoothed out.

The wall must be levelled out beforehand if larger cavities/bumps (larger than 4 mm) need to be compensated for.

Securing the wall mounting door (see Fig. on page 19)

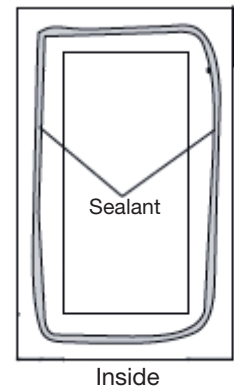

Securing to masonry

Insert the anchors supplied (Ø 10 mm) through the adjustable frame and if necessary through the additional frames into the boring holes and secure to the wall using the screws supplied.



If additional frames are used, correspondingly longer anchors and screws are required (see table on page 21).

Anchor and screw table (e. g. "fischer"):

Masonry and concrete

Frame	Requisite anchors	
1 frame (standard)	Ø x length = 10 x 100 mm	included
Add. 2nd frame	Ø x length = 10 x 115 mm	not included
Add. 3rd frame	Ø x length = 10 x 160 mm	not included
Add. 4th frame	Ø x length = 10 x 160 mm	not included

Insert the door panels in the hinges of the adjustable frame and push the pin in from the top (reverse order of description on page 17).



After inserting the door panel(s) in the frame, the pin must be fully enclosed inside the hinge. All of the pins must be rechecked after assembly.

Lock the door(s) using the turning lever or square.

The frame must be sealed all around on the outside once mounting is complete.

Order number
Fire protection putty
BSKITT

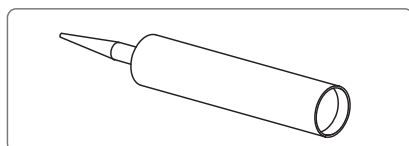

9 Commissioning

- ▶ During commissioning, please observe the safety information in section 2.
- ▶ Note the serial number on the rating plate which is indicated on the front page of this manual. This ensures that the manual is assigned to the correct housing.
- ▶ If necessary, mount a DIN single-cylinder lock, observing the exact assembly instructions.
- ▶ Ensure that the door swivel range is always free.
- ▶ Maximum door opening angle: 180°
- ▶ When the door is closed, it must be securely locked by the push rods.

- ▶ Check the integrity of the device each time before it is used.
- ▶ Check the correct position and integrity of all seals in particular.

- ▶ When planning and designing electrical systems in the fire protection housing, please consider the operating conditions ensuing from the use of the fire protection housing.
- ▶ When equipping the fire protection housing, please note its maximum heat dissipation.
- ▶ Please note that devices sensitive to temperature and humidity should not be installed behind the wall mounting door as they can cause the system to switch off prematurely.

- ▶ Go through the maintenance checklist in section 11.3.
- ▶ Confirm it as a “final inspection” on the maintenance label (see section 10).

10 Maintenance and repair

- ▶ During maintenance and repair, please observe the safety information in section 2.
- ▶ Hager fire protection housings should be regarded as technical safety systems which require maintenance and functional testing at least once a year.
- ▶ Go through the maintenance checklist in section 11.3 once a year. Make a copy of the maintenance checklist for this purpose.
- ▶ We recommend having this test carried out by an employee authorised by us as comprehensive knowledge and experience make for particularly thorough maintenance.
- ▶ We recommend a monthly visual inspection of the fire protection housing.
- ▶ If damage of technical safety relevance is detected, the wall mounting door must be repaired using original parts before further use.
- ▶ Clean the outside of the housing using a standard household cleaning agent.
- ▶ The door closing mechanism does not require any maintenance.

10.1 What to do after a fire

The housings may not be opened after a fire until a period of at least 6 times the fire duration has passed. Depending on the fire duration, an explosive vapour/air mixture may have developed inside the housing.

Before opening the housing, it must be disconnected from the power supply.
DIN VDE 0100 Part 460 and DIN VDE 0100 Part 537.

Housings must also be secured against direct contact by a safety barrier and marking.
DIN VDE 0100-410 and DIN VDE 0680.

Before opening the housing, all possible ignition sources within a radius of at least 10 metres must be removed.

Only use non-sparking tools when opening the housing.

11 Technical documents

11.1 General building inspectorate approval

The Deutsches Institut für Bautechnik (DIBt) has issued a general building inspectorate approval for the fire-resistant wall mounting door. This verifies the usability of the wall mounting door in line with the state building regulations.

The approval also specifies the following:

- The fire protection housing must be manufactured in a factory.
- The fire protection housing must bear a sign of conformity.
- Permanent in-plant monitoring of production to ensure that the product complies with the stipulations outlined in the approval.
- External monitoring at least twice a year during which the fire protection housing and its materials are examined.

You can download the current general building inspectorate test certificate from <http://www.hager.de> under Downloads, Test certificates.

11.2 EU Declaration of Conformity

In its EU Declaration of Conformity, Hager Tehalit Vertriebsgesellschaft mbH & Co. KG declares that all of its products bearing the **CE** mark comply with the requirements of the respective EU guidelines, where applicable.

The EU Declaration of Conformity does not however provide assurance of any particular properties.

If you wish to inspect the EU Declaration of Conformity, it is printed in our catalogue, or please contact the Technical Service Department (please refer to the back cover of this manual for details).

11.3 Forms and templates

Info note on delivery after transport

If the product supplied is incomplete or has been damaged during transport, please assert your claims within a period of 8 days.

To ensure that you do not incur any disadvantages, please note the following items of information:

- ▶ Check the packaging and its contents for completeness and integrity on delivery after transport. This guarantees that any transport damage which may have been incurred is not borne by you.
- ▶ The driver of the delivery vehicle is obliged to wait until you have inspected the transported goods. If the driver does not wish to wait, please note the vehicle license number and have the driver sign to confirm that he does not wish to wait.
- ▶ If transport damage or shortfall quantities are detected, please note these on the consignment note along with the vehicle license number and have the driver sign the note as confirmation. Reimbursement by our or your insurance is not possible without these documents.
- ▶ Leave damaged goods untouched and:
 - On delivery by post:
Please contact your local post office.
 - On delivery by forwarding agent:
Please contact our **Technical Service**:

E-Mail: technikblau@hager.de
Telephone: **0180 3847424***

*0,09 € per minute on Telekom landlines, rates may differ for mobile phones
(valid as at 11/2009)

Maintenance checklist

Complete a copy of the maintenance checklist every year, check to confirm the individual items and sign the form.

If you are unable to confirm individual items, the fire safety function is no longer guaranteed in full and you are obliged to take the appropriate steps without delay.

The Hager **Technical Service Department** would be delighted to provide you with support:

E-Mail: **technikblau@hager.de**

Telephone: **0180 3847424***

*0,09 € per minute on Telekom landlines, rates may differ for mobile phones
(valid as at 11/2009)

By confirming the individual items on this maintenance checklist, only obvious impairments of the effectiveness of fire safety can be excluded.

The respective personnel signs to confirm that the checklist does not release him/her from the obligation to permanently and carefully observe the fire-resistance effect of the system as a whole.

Name of inspector:	<input type="text"/>	Date:	<input type="text"/>
Serial number:	<input type="text"/>	Signature:	<input type="text"/>

Any damage to the fire protection panels?	<input type="checkbox"/>	Is the housing flush with the wall without any gaps?	<input type="checkbox"/>
Does the installation location still comply with the fire protection requirements complied with by the housing?	<input type="checkbox"/>	Is the manual inside the housing or within the reach of operating personnel?	<input type="checkbox"/>
Does the door/flap close tightly?	<input type="checkbox"/>	Do the push rods lock tightly?	<input type="checkbox"/>
Is the turning lever mounted firmly in place?	<input type="checkbox"/>	Is the housing screwed at all of the mounting holes?	<input type="checkbox"/>
Is the fire protection seal applied and undamaged on all sides of the door frame or door/flap?	<input type="checkbox"/>	Is the rating plate adhered firmly inside the housing?	<input type="checkbox"/>
Any corrosive damage?	<input type="checkbox"/>		

Imprint

Title	Manual Fire-resistant wall mounting door for 30 min. with exposure to fire from the outside or inside			
Publisher	Hager Electro GmbH und Co. KG			
Valid for	FB51WLN	FB62WLN	FB72WLN	FB81WLN
	FB52WLN	FB63WLN	FB73WLN	FB82WLN
	FB53WLN	FB64WLN	FB74WLN	FB83WLN
	FB61WLN	FB71WLN	FB75WLN	FB84WLN
Print run	5 th print run in March 2022			

©2022

Hager Electro GmbH und Co. KG

Reproduction, including of excerpts, only permissible with written approval.

Contact

Hager Electro GmbH und Co. KG
Zum Gunterstal 6
66440 Blieskastel
Germany
Tel.: +49 (0)6842 945-0
Fax: +49 (0)6842 945-516
<http://www.hager.de>

Technical Service
Energy Distribution & Meter Board Systems
Tel.: 0180 3847424*
E-Mail: technikblau@hager.de

*0,09 € per minute on Telekom landlines, rates may differ for mobile phones
(valid as at 11/2009)