

Radio button interface 4gang flush-mounted
Order-No. : 126

Operation- and
Assembly Instructions

1 Safety instructions

Electrical equipment may only be installed and fitted by electrically skilled persons.

Failure to observe the instructions may cause damage to the device and result in fire and other hazards.

Keep button cells out of reach of children! If button cells are swallowed, get medical help immediately.

Risk of explosion! Do not throw batteries into fire.

Risk of explosion! Do not recharge batteries.

Do not shorten, extend or strip the antenna. Device can be damaged.

Insulate wires which are not required and do not connect them to parts carrying voltage. Otherwise the device could be destroyed.

These instructions are an integral part of the product, and must remain with the end customer.

2 Device components

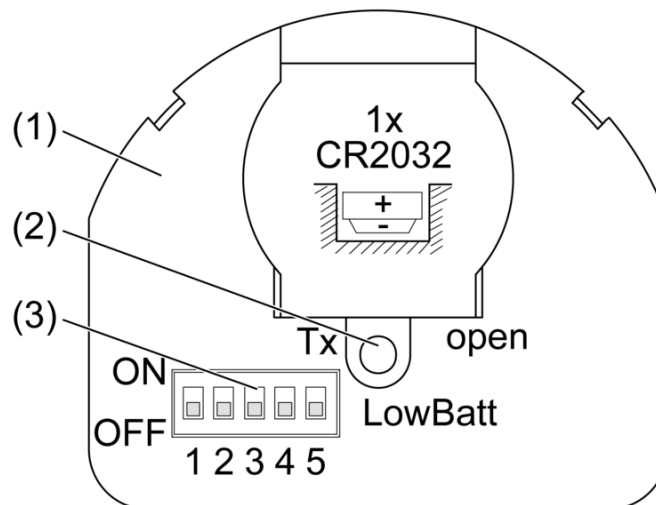

Figure 1

- (1) Transmitter
- (2) Red LED
- (3) Microswitch

3 Function

System information

By statute, the transmitting power, the reception characteristics and the antenna cannot be changed.

The device may be operated in all EU and EFTA countries.

The declaration of conformity can be viewed on our website.

The range of a radio system from the transmitter to the receiver depends on various circumstances.

The range of the system can be optimised by selecting the optimal installation location, taking into account the structural circumstances.

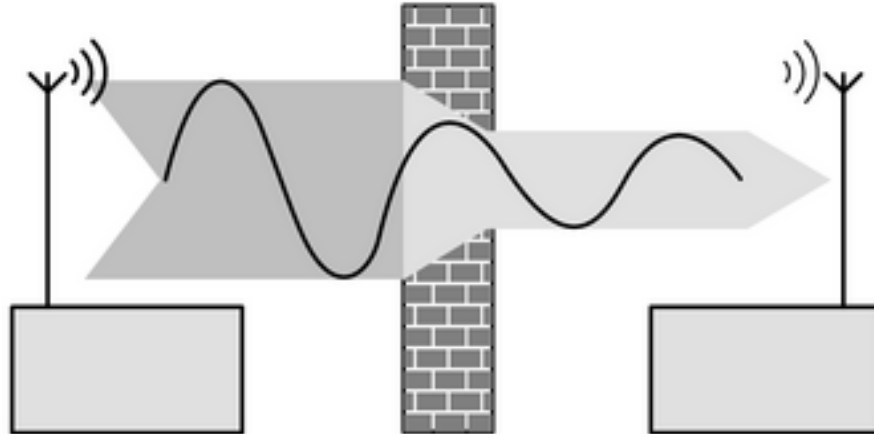

Figure 2: Reduced range due to structural obstacles

Example of penetration of various materials:

Material	Penetration
Wood, Plaster, Plasterboard	approx. 90%
Brick, Chipboard	approx. 70%
Reinforced concrete	approx. 30%
Metal, Metal grid	approx. 10%
Rain, Snow	approx. 1-40%

Intended purpose

- Radio transmitter to transmit switching, dimming, shutter movement and light scene commands
- Operation with potential-free switches or buttons
- Operation with suitable radio actuators
- Installation in appliance box to DIN 49073
- Observe the technical data.

Product characteristics

- 4 radio channels
- 8 operating modes settable
- Red LED signals "Transmission" or "Empty battery"
- Battery-operated device

i Blind operation only possible in operation mode 2 and in light scene operation, operation modes 5 to 8.

Overview of the operating modes

- Operating mode 1-2: Button connection
- Operating mode 3-4: Switch connection
- Operating mode 5-8: Light scene operation with buttons

4 Operation

Operation with button Operating mode 1, 1-area

In operating mode 1, 1-area switching and dimming (Figure 3) is possible with up to four buttons on the inputs **E1** to **E4**.

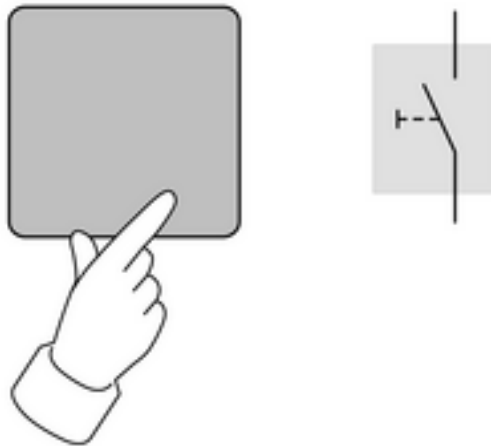

Figure 3: Operation, 1-area

Each time the button is pressed, the transmitter is switched, e.g. on/off, brighter/darker.

- Press the button briefly or for a longer period.
Receiver reacts according to the length of time for which the button is pressed (see following table).

Receiver	Short	Long
Switching actuator	Switch-on/off	Switch-on/off
Dimmer actuator	Switch-on/off	Brighter / darker

Operation with button Operating mode 2, 2-area

In operating mode 2, 2-area switching, dimming and blind movements (Figure 4) are possible with buttons. The inputs **E1/E2** and **E3/E4** each forms a channel.

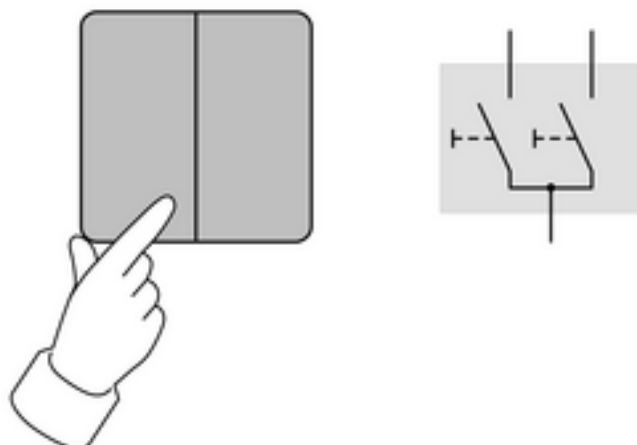

Figure 4: Operation, 2-area

One operating area is used to switch things on, to make the lights brighter or move a Venetian blind up. The other operating area is used to switch things off, to dim the lights or move a blind down.

- Press the button briefly or for a longer period.
Receiver reacts according to the length of time for which the button is pressed (see following table).

Receiver	Short	Long
Switching actuator	Switch-on/off	Switch-on/off
Dimmer actuator	Switch-on/off	Brighter / darker
Shutter actuator	Slat adjustment, stop	Shutter up/down

Operation with switch Operating mode 3 and 4

In these operating modes, only switching telegrams are sent meaning that, for example, dimming is not possible. The inputs **E1** to **E4** each offer a switching channel to control radio receivers.

In operating mode 3, the controlled switching actuator behaves like the switch connected to the transmitter.

In operating mode 4, the controlled switching actuator behaves in the opposite way to the switch connected to the transmitter.

- Actuate the switch rocker.
Receiver switches on or off.

Operation of light scenes Operating modes 5 to 8

In these operating scenes, light scenes can be opened or saved. For this, the light scene button must have been taught into the receiver in advance (see chapter 5.2. Commissioning).

- To open a light scene, briefly press the button on the appropriate input.
The receivers switch to the saved light scene value.
- To open the All On and All Off functions, press the button on the appropriate input for longer than one second.
The receivers switch on or off.

Operating mode 5

Input	Function
E1	All On
E2	All Off
E3	Light scene 1
E4	Light scene 2

Operating mode 6

Input	Function
E1	All Off
E2	Light scene 1
E3	Light scene 2
E4	Light scene 3

Operating mode 7

Input	Function
E1	All Off
E2	Light scene 3
E3	Light scene 4
E4	Light scene 5

Operating mode 8

Input	Function
E1	Light scene 1
E2	Light scene 2
E3	Light scene 3
E4	Light scene 4

5 Information for qualified electricians

5.1 Fitting and electrical connection



DANGER!

Electrical shock on contact with live parts in the installation environment.
Electrical shocks can be fatal.

Before working on the device, disconnect the power supply and cover up live parts in the working environment.

Connecting and mounting the device

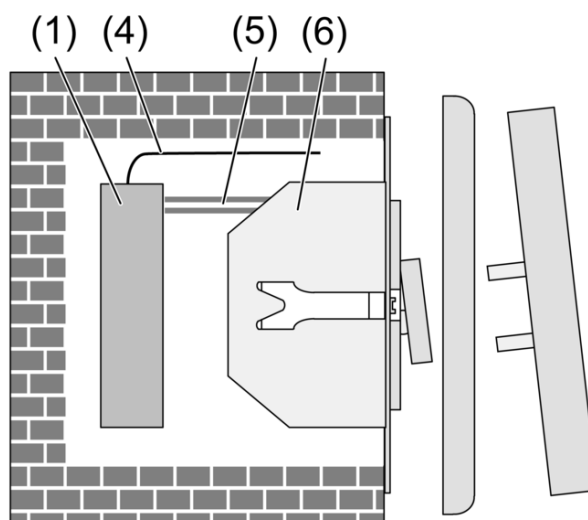

Figure 5

The transmitter is installed behind a potential-free switch or button (6) in a appliance box (Figure 5).

Keep a distance to large-area metallic parts, e.g. metallic door frames.

Maintain a distance of at least 1 m between transmitters and receivers.

radio bus Radio button interface 4gang flush-mounted

Ensure that the wires cannot be pulled or pushed.

- Set the operating mode (see the Commissioning chapter). The set operating mode can be changed at any time.
 - Connect the connectors of the eight-wire cable (5) and the white antenna to the transmitter.
- i** Lay the antenna (4) stretched out freely if possible.

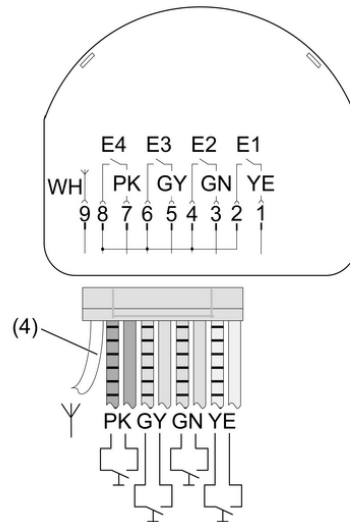

Figure 6

Colour coding of the wires

Yellow (YE) and yellow/black	Input E1
Green (GN) and green/black	Input E2
Grey (GY) and grey/black	Input E3
Pink (PK) and pink/black	Input E4

The cables marked in black form a shared reference potential.

- Connect potential-free switches and buttons to the eight-wire cable.
- Insulate unused wires.
- Insert the transmitter (1) in the appliance box.
- Mount the switches and buttons (6) in the appliance box.

Replacing the battery

The battery is already inserted on delivery. Replacement is only necessary when the battery is weak or empty.

LED display	Meaning
LED flashes on transmission	Battery OK
After transmission, LED again flashes very quickly	Battery weak
LED does not flash on actuating a connected button/switch	Battery empty

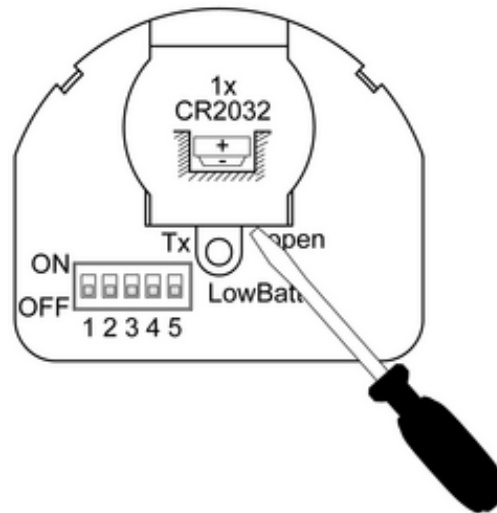

Figure 7: Opening the battery compartment

- Carefully open the battery compartment using a screwdriver.
- Remove the empty battery.

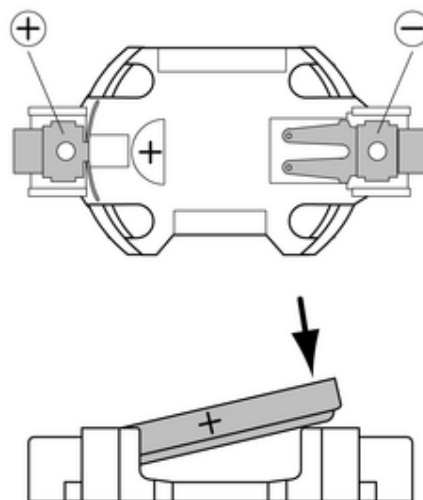

Figure 8: Inserting the battery

- Insert the new battery on the Plus contact of the battery holder. Observe the polarity: the Plus pole of the battery must be at the top.
- Lock the battery in place using slight pressure.
- Close the battery compartment.

5.2 Commissioning

Setting the operating mode

The eight operating modes are set using the 5x microswitch. For further explanation in the instructions:

ON = 1 and
OFF = 0.

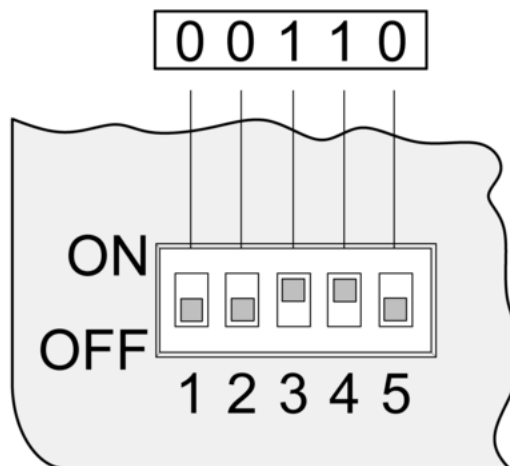

Figure 9

With the microswitch setting 00110 shown in the figure, operating mode 4 is set (Figure 9).

- Use a small screwdriver to set the appropriate operating mode (see following table).

Operating mode/ microswitch	Function	Control
1 00000	Switching/Dimming	Button
2 00010	Switching/Dimming/Blind	Button 2-button
3 00100	Switching	Switch, NO contact
4 00110	Switching	Switch, NC contact
5 01000	All On/Off, light scene 1/2	Button
6 01001	All Off, light scene 1-3	Button
7 01010	All Off, light scene 3-5	Button
8 01011	Light scene 1-4	Button

Implementing the "Bell mode" application example

In "Bell mode", a load, e.g. a bell or a lamp, is switched on for the time the button is pressed.

With a switching actuator as a receiver:

- Set operating mode 3.
- Connect a button instead of a switch.
When the button is pressed, the switching actuator closes its contact and releasing the button reopens the contact.

With a touch actuator as a receiver:

- Set operating mode 2.
- Actuate the switch-on channel **E1** or **E3**.
The behaviour of the touch actuator is described in the touch actuator operating manual.

radio bus**Radio button interface 4gang flush-mounted**

- i** The maximum transmission time is 12 s, even if another connected button is pressed afterwards.

Teach-in transmitter

For a receiver to understand a radio telegram from a transmitter, the receiver must "learn" this radio telegram. A transmitter channel can be taught into any number of receivers. The teaching process only creates an allocation in the receiver.

On teaching a transmitter, the receiver range is reduced to approx. 5 m. The distance between the receiver and the transmitter to be taught should therefore be between 0.5 m and 5 m.

Teach transmitter in operating mode 1 or 2

Microswitches are set to operating mode 1 or 2.

- Switch the receiver to Programming mode (see transmitter instructions).
- Press the button of the desired input for at least 1 s.
With two-area modes, actuate only one button per channel.
- Exit the Programming mode of the receiver (see transmitter instructions).
Transmitter has been taught-in.

Teach transmitter in operating modes 3 or 4

- Set the microswitch to 00000.
- Switch the receiver to Programming mode (see transmitter instructions).
- Press the connected switch of the desired input for at least 1 s.
- Set the microswitch to the required mode 3 or 4.
- Exit the Programming mode of the receiver (see transmitter instructions).
Transmitter has been taught-in.

Teach transmitter in operating modes 5 to 8

Microswitches are set to one of the operating modes 5 to 8.

- Switch the receiver to Programming mode (see transmitter instructions).
- Depending on the selected function, actuate the light scenes button for at least 3 s or actuate the All On or All Off button for at least 10 s.
- i** When teaching in a light moods button, the All On and All Off button is also taught in automatically in the receiver.
- Exit the Programming mode of the receiver (see transmitter instructions).
Transmitter has been taught-in.

Deleting a transmitter

- Teach-in the transmitter to be deleted again in the same operating mode.

Changing the All On / All Off function

- i** This function is only available in operating modes 5 to 7.

The All On / All Off function is automatically taught in on teaching in the transmitter. The function must be changed if receivers are not to react to the All On / All Off function.

Example: a receiver should not react to the All On function, all the other receivers should switch the light on.

- Press the All On button for at least 1 s.
All the taught in receivers are switched on.
- Set the lighting in the way it should react when the All On button is pressed, i.e. as all the receivers are switched on, now, for example, switch off the light in the bathroom.
- Press the All On button for at least 10 s.
Firstly, open the old lighting setting. Do not release the button. After about 10 s the new setting is saved and activated.
The reallocation of the All On button is complete. Proceed in the same manner to change the All Off button.

Save light scene

i This function is only available in operating modes 5 to 8.

Light scene button of the transmitter has been taught-in.

- Set the required lighting situation.
- Press the required light scene button for at least 3 s.
Firstly, the old light scene button is opened, do not release the button. After about 3 s the new light scene is saved and activated.

i If, when a light scene is saved, the shutter is not in the end position or on the way there, this shutter is not integrated into the light scene.

6 Appendix



Remove empty batteries immediately and dispose of in an environmentally friendly manner. Do not throw batteries into household waste. Consult your local authorities about environmentally friendly disposal. According to statutory provisions, the end consumer is obligated to return used batteries.



The symbol confirms the conformity of the product to the relevant guidelines.

6.1 Technical data

Rated voltage	DC 3 V
Battery type	1×lithium CR 2032
Cable length	approx. 290 mm
Carrier frequency	433.42 MHz (ASK)
Transmitting range in free field	typical 100 m
Protection rating	IP 20
Ambient temperature	-20 ... +55 °C
Relative humidity	max. 65 % (No moisture condensation)
Dimensions L×W×H	45×40×10 mm

6.2 Troubleshooting

Device does not respond, or only sometimes.

Cause 1: battery in the radio transmitter is empty.

Change the battery in the radio transmitter.

Cause 2: Radio range exceeded. Structural obstacles reduce the range.

Check the installation situation.

Check routing of antenna. Laying the antenna stretched out increases the range.

Using a radio repeater.

6.3 Warranty

We reserve the right to make technical and formal changes to the product in the interest of technical progress.

Our products are under guarantee within the scope of the statutory provisions.

If you have a warranty claim, please contact the point of sale or ship the device postage free with a description of the fault to the appropriate regional representative.

Berker GmbH & Co. KG

Klagebach 38
58579 Schalksmühle/Germany
Telefon + 49 (0) 2355/905-0
Telefax + 49 (0) 2355/905-111
www.berker.de