

Radio switch actuator 2gang flush-mounted
Order No. : 129

Operation- and Assembly Instructions

1 Safety instructions

Electrical equipment may only be installed and fitted by electrically skilled persons.

Serious injuries, fire or property damage possible. Please read and follow manual fully.

Danger of electric shock. Always disconnect before carrying out work on the device or load. At the same time, take into account all circuit breakers that supply dangerous voltage to the device or load.

Danger of electric shock. Device is not suitable for disconnection from supply voltage.

Do not use device as a venetian blind actuator. Otherwise the Venetian drive motor may be destroyed.

The radio communication takes place via a non-exclusively available transmission path, and is therefore not suitable for safety-related applications, such as emergency stop and emergency call.

Danger of electric shock. Insulate unused wires.

Danger of electric shock. The antenna has basic insulation. Do not lead it through the appliance box.

Do not shorten, extend or strip the antenna. Device can be damaged.

These instructions are an integral part of the product, and must remain with the end customer.

2 Device components

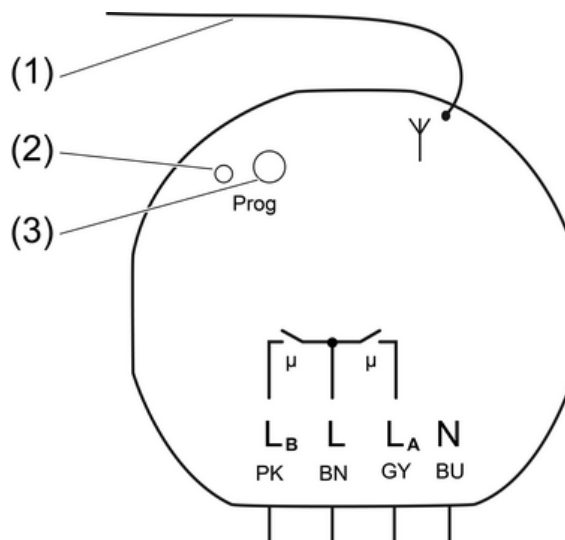

Figure 1

- (1) Antenna
- (2) LED, two-colour
- (3) Programming button

3 Function

System information

By statute, the transmitting power, the reception characteristics and the antenna cannot be changed.

The device may be operated in all EU and EFTA countries.

The declaration of conformity can be viewed on our website.

The range of a radio system from the transmitter to the receiver depends on various circumstances.

The range of the system can be optimised by selecting the optimal installation location, taking into account the structural circumstances.

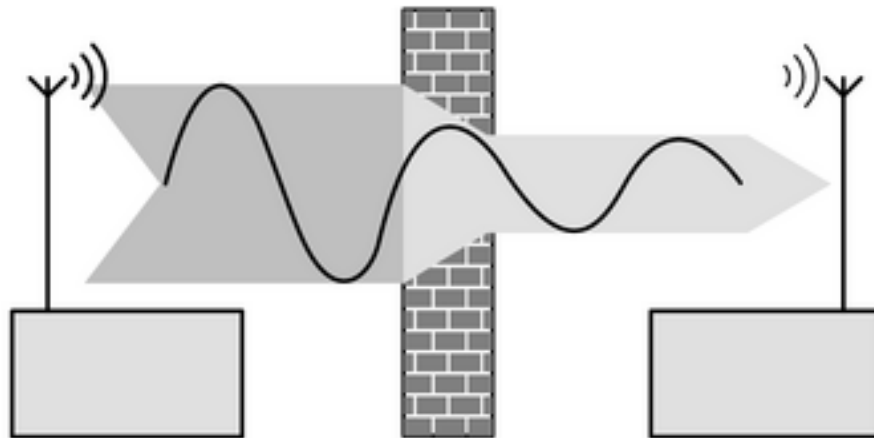

Figure 2: Reduced range due to structural obstacles

Example of penetration of various materials:

Material	Penetration
Wood, Plaster, Plasterboard	approx. 90%
Brick, Chipboard	approx. 70%
Reinforced concrete	approx. 30%
Metal, Metal grid	approx. 10%
Rain, Snow	approx. 1-40%

Intended use

- Radio-controlled switching of incandescent lamps, fluorescent lamps, HV halogen lamps and Tronic or inductive transformers with halogen lamps
- Operation with suitable radio transmitters
- Suitable for mixed operation up to the specified output (Technical data)
- Mounting in appliance box according to DIN 49073

i It is not possible to teach a combination of presence detector and motion detector.

Product characteristics of the switch actuator

- Independent switching of two electrical loads
- Light scene operation possible
- 2-point light control in combination with a radio presence detector possible
- Run-on time of approx. 1 minute in connection with radio motion detectors.

4 Operation

A radio transmitter has to be taught in order to be able to operate the device.

i Observe the instructions for the radio transmitter.

5 Information for electrically skilled persons

5.1 Fitting and electrical connection



DANGER!

Electrical shock when live parts are touched.

Electrical shocks can be fatal.

Before carrying out work on the device or load, disengage all the corresponding circuit breakers. Cover up live parts in the working environment.

Connecting and fitting the device

Maintain a distance of at least 0.5 m from metal surfaces and electrical devices, e.g. microwave ovens, hi-fi and TV systems, electronic ballasts or transformers.

Maintain a distance of at least 1 m between transmitter and receiver in order to prevent overmodulation of the receiver.

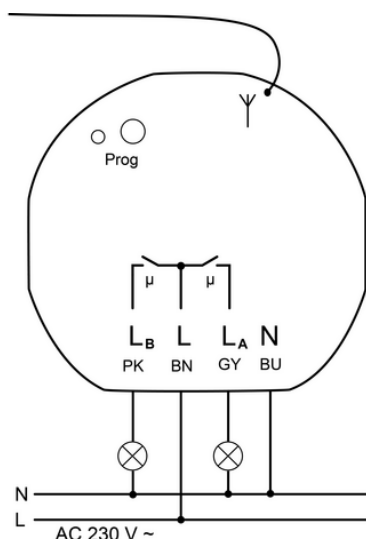

Figure 3: Connection example

Pink conductor (PK) - L_B, output B

Brown conductor (BN) - L, live conductor, AC 230 V ~

Grey conductor (GY) - L_A, output A

Blue conductor (BU) - N, neutral conductor

- Connect actuator to lamp terminals according to connection example (Figure 3) (see Using the lamp terminals).

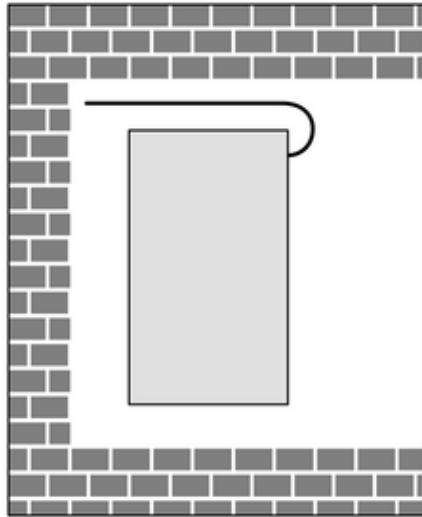

Figure 4: Installation in appliance box

- Insert the device in the appliance box in such a way that the programming button and the LED are visible.
- i** Lay the antenna stretched out freely if possible(Figure 4).
- i** For mounting outside of the appliance box, e.g. baldachin luminaires, ensure sufficient protection against electric shock.
- Switch on mains voltage.

Testbetrieb am Gerät

The device can be started by pressing the programming button briefly several times in sequence, for about 1 second, see table.

Operations	Output L _A	Output L _B	LED
1 x	ON	OFF	red
2 x	OFF	ON	green
3 x	ON	ON	red/green
4 x	OFF	OFF	OFF

- Perform commissioning.
- Mount the cover.

Using the lamp terminals

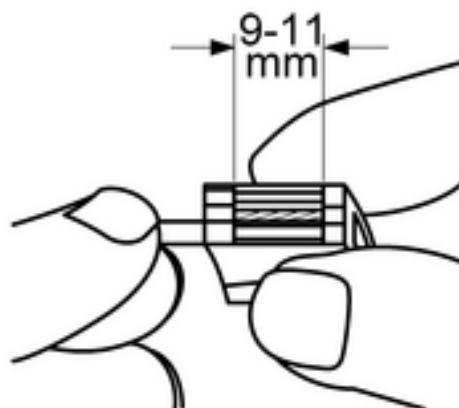

Figure 5: Stripping length

- Strip 9 - 11 mm of the cable (Figure 5).

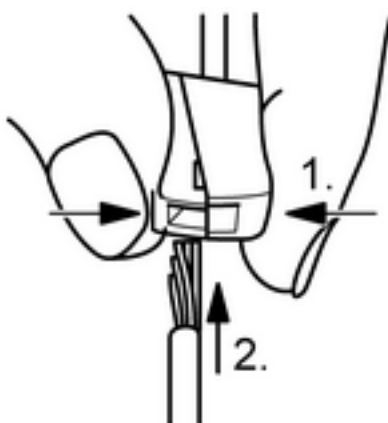

Figure 6: Connection of the fine-wire cable

- Push the terminal together on the side with the square opening and connect a fine-wire cable (Figure 6).

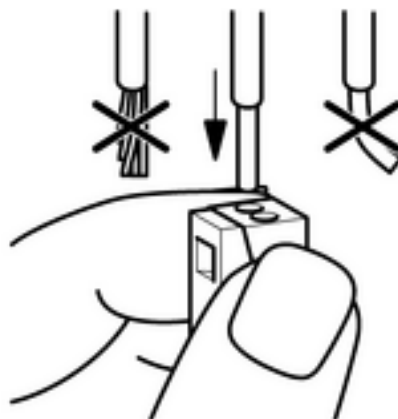

Figure 7: Connection of the single-stranded cable

- Push the single-stranded cable into the round opening on the installation side up to the stop (Figure 7).

5.2 Commissioning

- i** Observe the instructions for the radio transmitter.



DANGER!

Electrical shock when live parts are touched.

Electrical shocks can be fatal.

During commissioning, cover the parts carrying voltage on radio transmitters and actuators and in their surrounding area.

Teaching a radio transmitter

- i** If all memory slots of an output are occupied, a radio transmitter which has already been taught must first be deleted. To do this, delete all taught channels and light scenes of the radio transmitter individually.

The distance between the receiver and the radio transmitter is from 0.5 m to 5 m.

Load is switched off.

- Press the programming button for approx. 4 seconds.
LED flashes red Device switches the connected loads off and is in programming mode for output A for approx. 1 minute.
- i** To enter the programming mode for output B, press programming button again for 4 seconds. LED flashes green
- Trigger teach telegram on radio transmitter, see instructions for radio transmitter.
LED lights up red for output A or green for output B.
The radio transmitter has been taught.
- Press the programming button briefly.
The load switches on. The device is in operating mode.
- i** The programming mode is exited automatically after about 1 minute.
- i** Only switch actuator: When a radio transmitter is taught, All On and All Off buttons that are present are automatically also taught.
- i** Only switch actuator: Teach light scene push-buttons separately.

Deleting radio transmitters individually

- Teach the radio transmitter to be deleted again (see Teaching the radio transmitter).
LED flashes quickly in the colour corresponding to the output. The radio transmitter has been deleted.
- i** If several channels or light scenes of a radio transmitter have been taught, they all must be deleted individually.

6 Appendix



The icon confirms the conformity of the product to the relevant guidelines.

6.1 Technical data

Rated voltage	AC 230 / 240 V ~
Mains frequency	50 / 60 Hz
Ambient temperature	-20 ... +55 °C
Relative humidity	approx. 0 ... 65 % (No moisture condensation)
Total power consumption	max. 2300 W/VA
Connected load per output	
Incandescent lamps	2300 W
HV halogen lamps	2300 W

radio bus
Radio switch actuator 2gang flush-mounted

Tronic transformers	1500 W
Inductive transformers	1000 VA
Fluorescent lamps, uncompensated	1200 VA
Fluorescent lamps, parallel compensated	920 VA
Switching current per output (ohmic)	10 A
Minimum switching current AC	100 mA
Contact type	μ contact
Connection	
single stranded	1.0 ... 2.5 mm ²
Dimensions Ø×H	53×28 mm
Carrier frequency	433.42 MHz (ASK)
teachable radio transmitters per output	max. 7

6.2 Troubleshooting

Device does not respond, or only sometimes.

Cause 1: battery in the radio transmitter is empty.

Change the battery in the radio transmitter.

Cause 2: Radio range exceeded. Structural obstacles reduce the range.

Check the installation situation.

Check routing of antenna. Laying the antenna stretched out increases the range.

Using a radio repeater.

The device switches the load off and cannot be switched on again.

Cause: overheating protection has tripped.

Disconnect device from mains, also switch associated off circuit breakers.

Let device cool down for at least 15 minutes.

Check the installation situation.

Reduce the connected load.

Switch circuit breakers on again.

6.3 Warranty

We reserve the right to make technical and formal changes to the product in the interest of technical progress.

Our products are under guarantee within the scope of the statutory provisions.

If you have a warranty claim, please contact the point of sale or ship the device postage free with a description of the fault to the appropriate regional representative.

Berker GmbH & Co. KG

Klagebach 38

58579 Schalksmühle/Germany

Telefon + 49 (0) 2355/905-0

Telefax + 49 (0) 2355/905-111

www.berker.de