

VME02SPD
Installation
Instructions

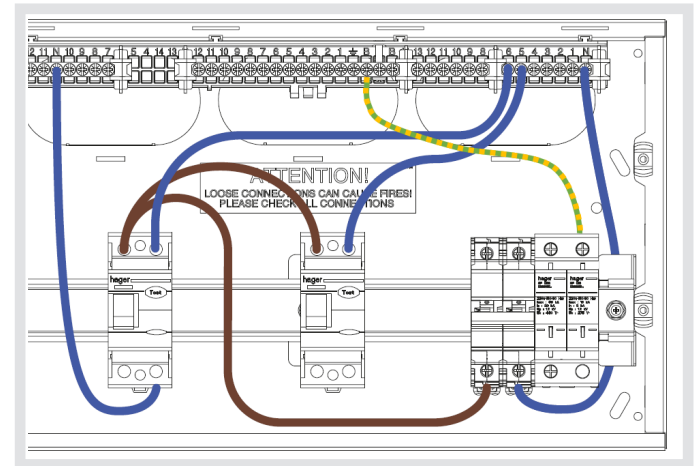

Surge Protection Kit

ZD0906

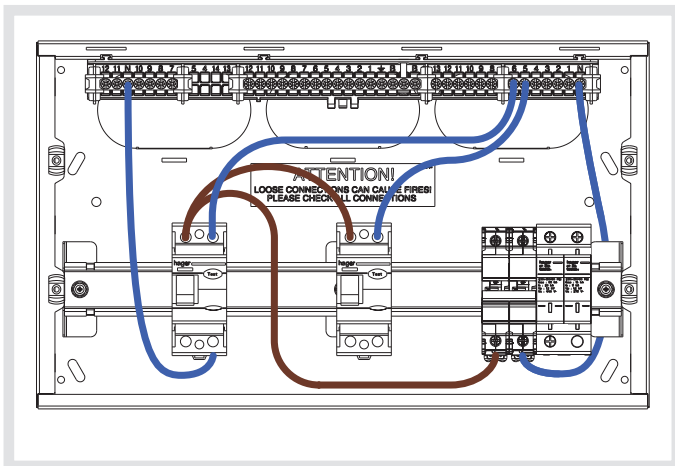
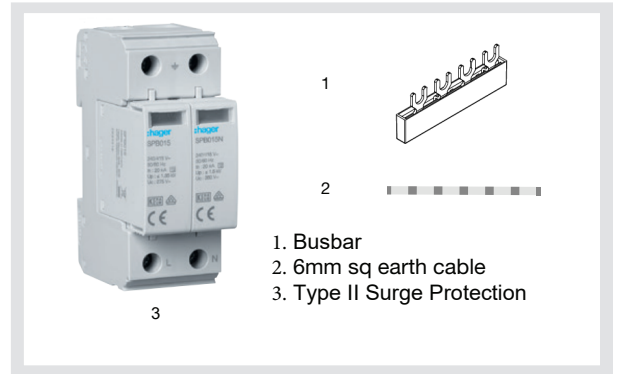

Move the main switch over 2 modules and clip the Surge protection device on the right hand side of the main switch.

Fit the 6mm earth cable into one of the terminals in the top of the SPD and terminate in the earth bar. Torque to 3.6Nm.

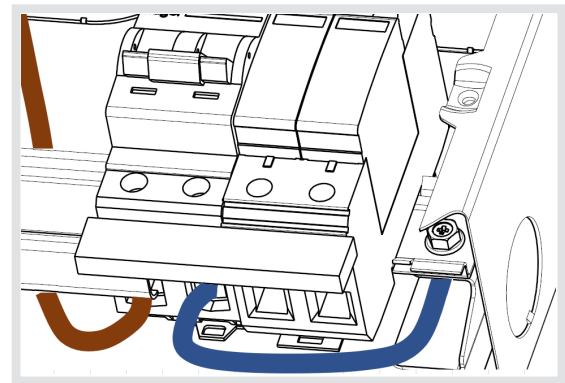
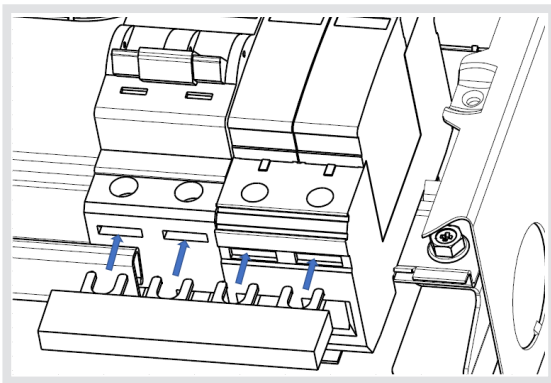

Loosen the bottom terminals on the Main switch and Surge protection device and insert the busbar into the rectangle slots above the cage terminals.

Push the busbar firmly against the Surge protection device making sure the cables below are secure and torque back to 3.6Nm.

Replacement cartridges - SPB015, SPB015N

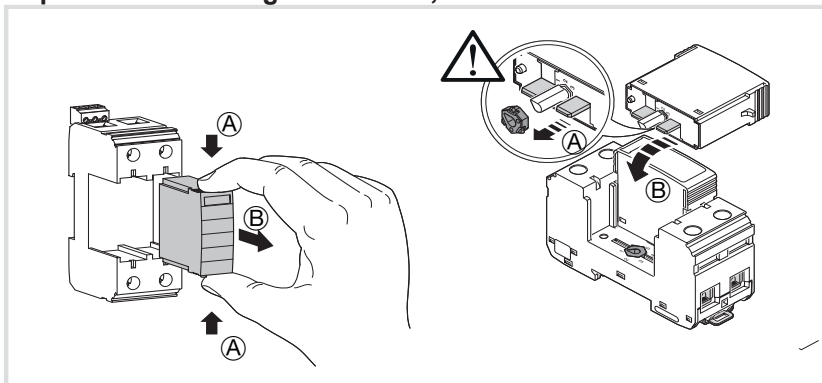

Fault indication

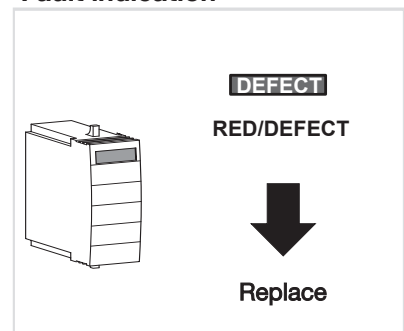

ZD0906