

# 16AX two way switch mechanism

Catalogue number:  
**WBM16AX**

## Specifications:

### Regulatory

- Tested to AS/ NZS 3133:2008 + A1
- Approval no : 1454

### Electrical

- 16AX, M60, 240V, 50Hz, AC rating

### Mechanical

- External material UV stabilised polycarbonate

### Packaging

- Box qty 5
- Carton qty 720

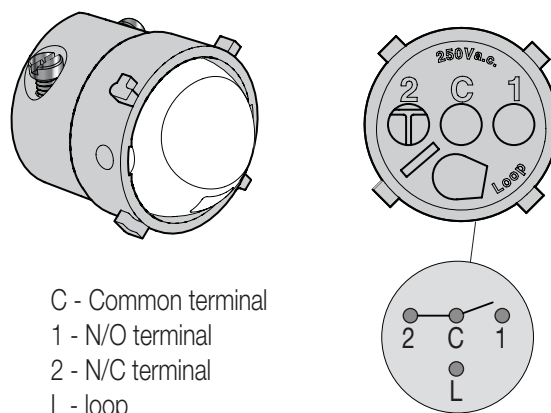

C - Common terminal  
1 - N/O terminal  
2 - N/C terminal  
L - loop

Feature	Benefit
Rotoloc compatible	Mechanism will not pushback through plate into wall cavity
Terminal screws "backed off"	Ease of installation
Cable entries bevelled	Ease of installation
Rocker arc shield	Reduces visible arc flash from switching
Chemical resistant rocker pivots	Increased resistance to chemical cleaners
UV stabilised, PC material	Does not fade, high impact strength