

## WBMDUR Rotary dimmer V2

### Safety instructions

Electrical equipment must only be installed and assembled by a qualified electrician in accordance with the relevant installation standards, guidelines, regulations, directives, safety and accident prevention regulations of the country.

Failure to comply with these instructions may result in damage to the device, fire or other hazards.

**Hazard due to electric shock.** The device is not suitable for safe disconnection of the mains supply. Even when the device is switched off, the load is not isolated from the mains supply.

**Do not connect non-dimmable lamps, their transformers or operating devices.** Observe manufacturer's data.

These instructions are an integral component of the product and must be retained by the end user.

### Design and layout of the device

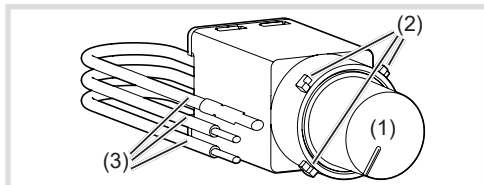

Fig. 1: Front view

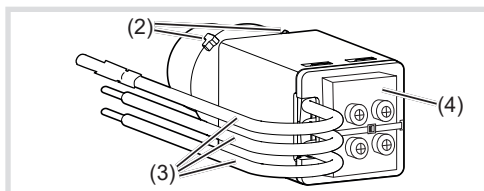

Fig. 2: Rear view

**i** The terminal block must be mounted in either its original shipped position or on the rear of the module by means of the enclosed cable tie.

- (1) Rotary knobs
- (2) Retaining lugs for Rotoloc® fastening
- (3) Connection cable
- (4) Terminal block

### Function

#### Correct use

- Switching and dimming of incandescent lamps, HV halogen lamps and dimmable 230 V LED lamps; electronic transformers with low voltage halogen lamps.
- Unsuitable for fans and motors
- Suitable for indoor use only, but no drip and no spray water.
- Suitable for Hager Rotoloc switch plates only

#### Product characteristics

- Phase cut-off dimmers
- Wide dimming range down to the lowest brightness for many lamps
- Programmable minimum brightness
- Additional configurable functions
- Automatic storage of the switch-off brightness level as switch-on brightness level
- Electronic short circuit, overload and thermal protection
- Multi-way dimming available only with use of the WBMSLL slave mechanisms
- Non volatile device settings

### Control

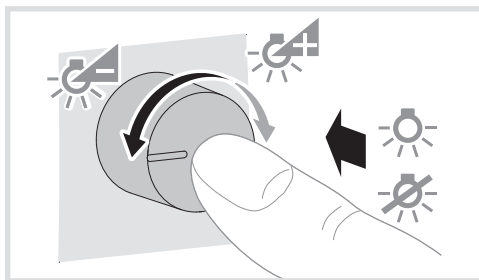

Fig. 3: Rotary dimmer operation

Load state	Action	Result
OFF	Short press rotary knob	Switch <b>ON</b> with saved switch-on brightness level.
> 0%	Short press rotary knob	Switch <b>OFF</b> and save brightness as switch-on brightness level.
> 0%	Turn rotary knob anticlockwise	Dim down the light.
> 0%	Turn rotary knob clockwise	Dim up the light.

Table 1: Rotary dimmer operation



### End of life treatment of electrical/electronic equipment and batteries in the European Union countries.

The crossed-out 'wheeled bin symbol' marked on the equipment or its packaging, indicates that this product is not to be disposed off with unsorted municipal / household waste. Please check with your local authority or retailer for recycling and collection advice. This will enable you to contribute to the disposal, treatment and recycling in an environmentally sound way and help to prevent potential negative effects on the environment and human health.

### Setting the minimum brightness level

The minimum brightness level can be adjusted to prevent poor switch-on behaviour or flickering of the load in the lower dimming range.

- Switch off load.
- Press and hold rotary knob for approx 10 seconds.  
The load will flash once after 3 seconds and then flash a second time after 10 seconds.
- After the 10 second flash, release the rotary knob.  
- The device is in fine adjustment mode for the minimum brightness level and the lamp is switched on at the minimum brightness level.
- Rotate the rotary knob to the minimum brightness level required
- Wait 10 seconds for the load to turn off and dimmer to store setting

**i** Depending on the lamp, the minimum brightness level of the lights installed may be too low and the lights may appear off, gradually increase the brightness level by rotating the knob clockwise.

**i** If no actions are performed within 10 seconds, the dimmer exits programming operation.

### Additional Settings

The additional settings can be configured by pressing the rotary dimmer for the required number of times. Refer to Table 2.

#### 1. Kick-start

A short voltage burst when lamp is initially turned on to support lamp start-up.

#### 2. Reduced maximum brightness

A non-adjustable voltage reduction for suppressing flickering at maximum brightness.

#### 3. Always on. Disable push on/off

To become a basic dimmer – requires separate external switch

#### 4. Recover load state after power outage

The status of the load prior to power loss will be restored at power-on.

#### 5. Always turn load on at 100%

For loads that do not turn on when switched off at low dim setting

### How to configure additional settings

- Switch off load.
- Press and hold rotary knob for approx 10 seconds.  
- The load will flash once after 3 seconds and then flash a second time after 10 seconds.
- Release the rotary knob.
- Press rotary knob again for approx. 3 s until the load flashes once.
- Release the rotary knob.  
- You are now in Additional Settings Selection Mode.
- Press the knob the correct number of times according to Table 2. Wait for the load to flash after each press.  
- Once selected, wait 10 seconds for the load to turn off and store your selection.  
- If Always On function is selected, wait 10 seconds and manually turn the load off with the switch.

### **i** Important regarding Always On mode:

- For Always On function, the dimmer must be wired to a separate switch as per Fig 4
- Ensure minimum & maximum settings are programmed prior to entering into Always On mode.
- To exit 'Always On' mode – a factory reset must be performed

Configurable additional functions	Factory setting	Number of times the rotary knob is pressed
Kick-start	OFF	1 x
Reduced maximum brightness	OFF	2 x
Always On Disable On/Off	OFF	3 x
Recovery of the load state when the power is restored	OFF	4 x
Turn on 100%	OFF	5 x

Table 2: Configurable additional functions

### Reset to factory setting (excluding from Always ON)

- From OFF position
- Press and hold rotary knob for approx 10 seconds.  
The load will flash once after 3 seconds and then flash a second time after 10 seconds.
- Release the rotary knob.
- Press and hold rotary knob again for another 10 seconds.  
The load will flash once after 3 seconds and then flash a second time after 10 seconds.
- Release the rotary knob.  
The reset has been completed, the load is switched off and the dimmer is in standard operation with the factory settings being effective.

### Reset to factory setting (from Always ON)

- Press and hold rotary knob for approx 10 seconds.  
The load will blink off once after 3 seconds and then again after 10 seconds.
- Release the rotary knob.
- Press and hold rotary knob again for approx 10 seconds.  
The load will blink off once after 3 seconds and then again after 10 seconds.
- Release the rotary knob.  
The reset has been completed, the load is switched off and the dimmer is in standard operation with the factory settings being effective.

## Information for electricians

### Installation and electrical connection

**⚠ DANGER!**  
Electrical shock when live parts are touched!  
An electric shock can lead to death!  
Isolate all power before working on the device and cover any live parts in the area!

### Connection Diagram (Always On Only)

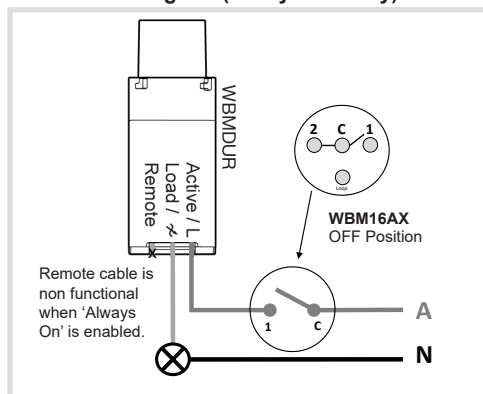

Fig. 4

### Connection diagram (Excluding Always On)

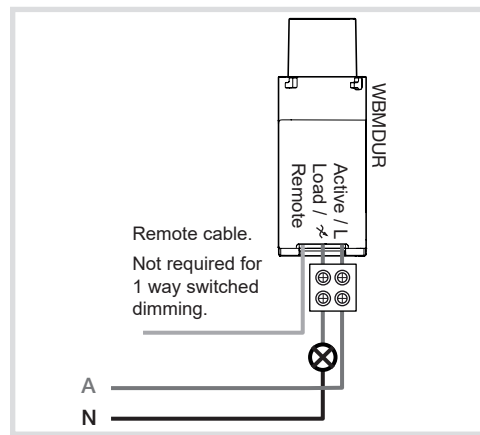

Fig. 5: One way connection

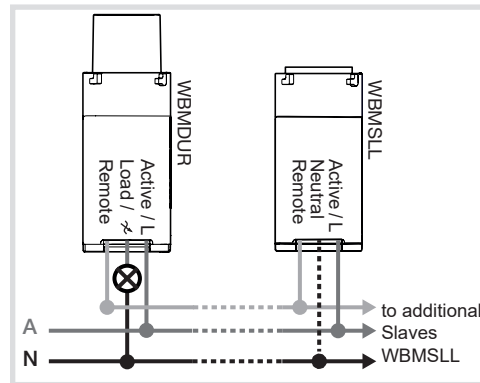

Fig. 6: 2 way connection

- Load side of device is not considered isolated in OFF position.
- Install a circuit breaker of max. 10 A as device protection.
- For 2 way or multiple way switching. Refer to WBMSLL instructions.

## Appendix

### Technical data

Operating voltage	230 V~ +/-10%
Frequency	50 Hz
Miniature circuit breakers	max. 10 A
Degree of protection	IP2X
Standby power consumption	< 0.07 W
230 V incandescent lamps, halogen lamps and cold-light reflector lamps	7 ... 300 W
Dimmable, electronic transformers with low voltage halogen lamps	20 ... 350 W
Dimmable 230 V LED lamps	3 ... 250 W
Slave units cable length	
- in one cable	max. 20 m
- in separate cables	max. 50 m
Terminal block cables	max. 2 x 1.5 mm <sup>2</sup> max. 1 x 2.5 mm <sup>2</sup>
Flying leads, flexible	100 mm x 1,5 mm <sup>2</sup>
Operating temperature	-5 to 50 °C
Storage temperature	-20 to 70 °C
Relative humidity (without dewing)	0 ... 65 %

### Note:

LED loads should be tested with this dimmer prior to installation. Some LED loads may not be compatible due to the type of LED driver within the LED light.

## Operating conditions

Number of dimmers per combination	Connect load reduction
1	100%
2	75%
3	55%
4	40%
5	35%
6	30%

Table 3: Dimmer combination load reduction

When operating multiple dimmers in the same switch plate, the maximum connected load must be reduced depending on the number of dimmers as per Table 3 above.

Load type	Maximum output power (W)		
	25 °C	35	50 °C
Ohmic loads	300	265	210
Dimmable, electronic transformers with low voltage halogen lamps	350	310	250
230 V LED lamps	250	220	175

Table 4: Reduced performance, ambient temperature

- Carry out loading of conventional, electronic transformers according to manufacturer's instructions.
- Do not use non-dimmable 230 V LED lamps.
- If 230 V LED lamps are used, the power supply to the dimmer can cause the lamp to glow slightly even when it is switched off.

## Troubleshooting

### Dimmer switches off of its own accord.

The electronic overload protection has tripped.  
Check the load connected (excessive load).  
Reduce the number of lamps or use lamps with a lower power rating.  
The electronic short-circuit protection has tripped.  
Check electrical installation.

### The load cannot be dimmed down sufficiently.

The dimming angle is set too high.  
Decrease the value in fine-setting of the minimum brightness.

### The load switches off while being dimmed down.

The dimming angle is set too low.  
Increase the value in fine-setting of the minimum brightness.

### The load does not switch on.

The dimming angle and brightness value are set too low.  
Increase the value in fine-setting of the minimum brightness.

### Load flickers while switched off.

LED load too low.  
Increase LED load at output.

### The connected load cannot be dimmed or load flickers while switched ON.

Lamps are not suitable for dimming.  
Be sure always to use dimmable loads.

### Undefined fault during operation.

Slave unit cable length is too long or no separate slave unit cable has been used.  
Keep to slave unit cable length or, if necessary, use separate slave unit cable.