

- ⒹⒺ NH-Sicherungslasttrennschalter
- ⒼⒹ HRC fuse-switch-disconnectors
- ⒻⒼⒾ Fusible-interrupteur-sectionneur
- ⒾⒿ Sezionatore portafusibili

Montageanleitung

Installation instruction

Notice d'instructions

Istruzioni per il montaggio

87536.0300

NH000

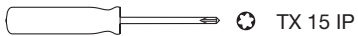

ⒹⒺ

- Vor Beginn der Arbeiten Anlagen und Gerät spannungsfrei schalten.
- Sicherungseinsätze und Trennmesser mit versilberten Oberflächen einsetzen.
- Zügig schalten

ⒻⒼⒾ

- Avant le début des travaux, mettre les installations et l'appareil hors tension.
- Veuillez utiliser des fusibles et des couteaux de coupure avec des contacts argentés.
- Mettre en circuit rapidement

ⒼⒹ

- Always switch off the power to the systems and equipment before starting your work.
- Utilize silver-coated fuse-links and isolating blades.
- Operate quickly

ⒾⒿ

- Prima di iniziare il lavoro togliere la tensione dall'impianto e dall'apparecchio.
- Utilizzare fusibili e coltelli divisori con contatti argentati
- Operare rapidamente

Sammelschienen Montage / Busbar assembly / Montage sur jeu de barres / Montaggio su sbarra collettice

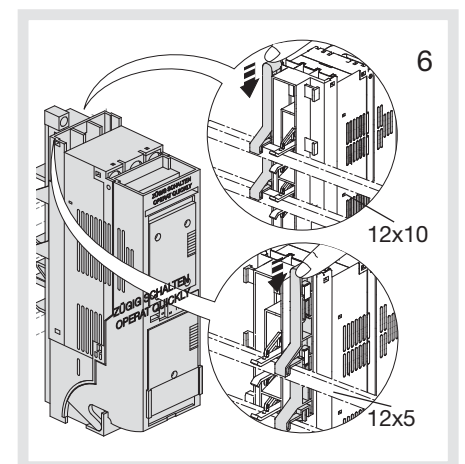
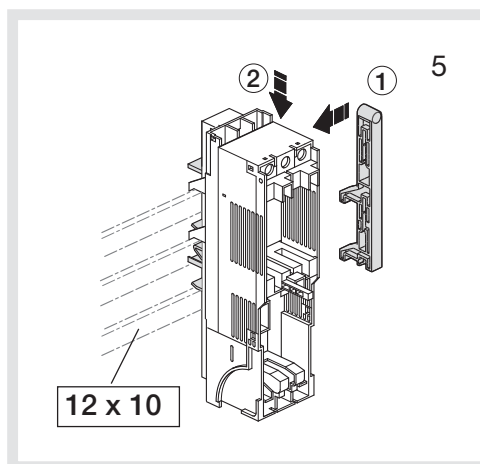
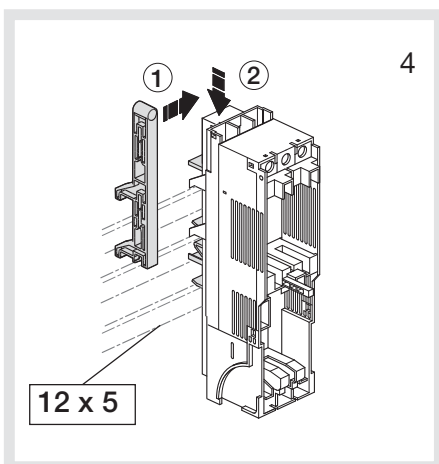
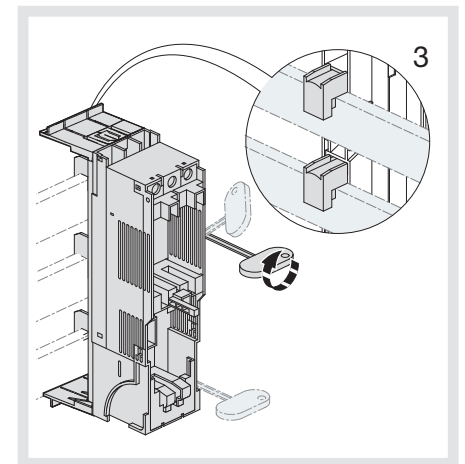
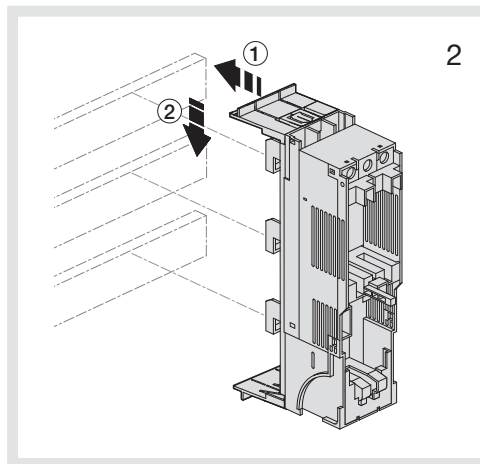
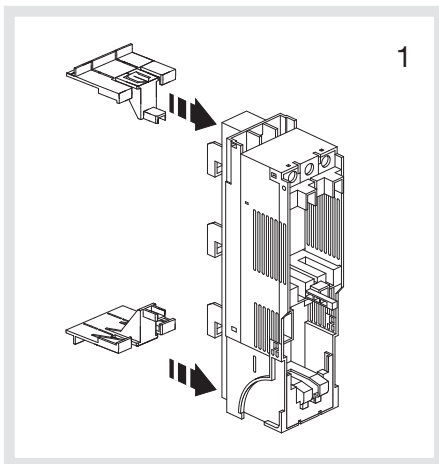

Kabelanschlüsse
Cable connections
Raccords de câbles
Collegamento dei cavi

Verriegelung/Plombierung
Locking/sealing facility
Verrouillage/plombage
Blocco/Piombatura

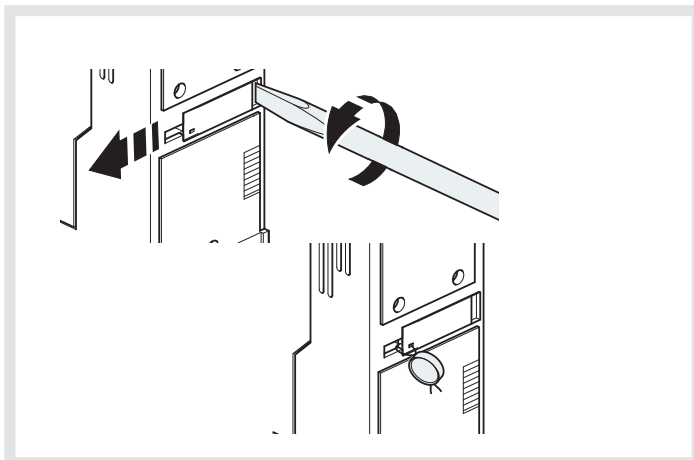
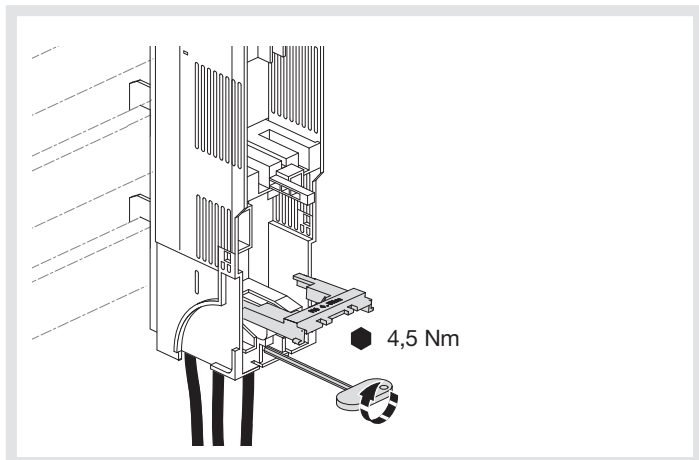

Zubehör / Accessories / Accessoires / Accessori

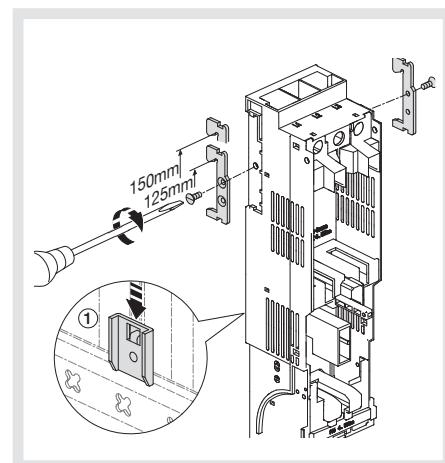
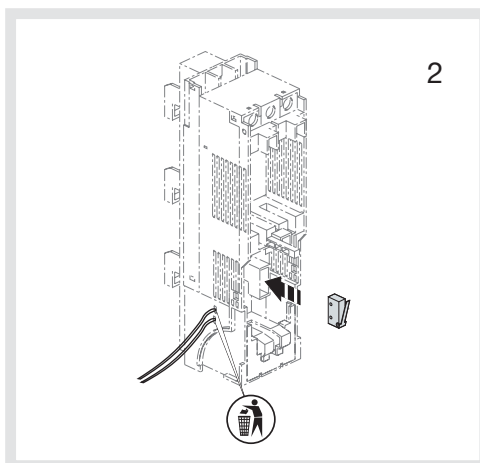
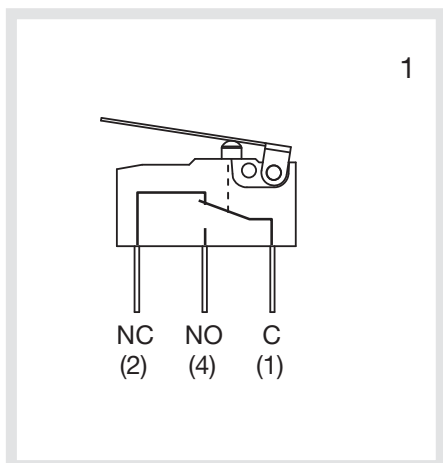

Sicherungsüberwachung
Fuse monitoring
Surveillance des fusibles
Monitoraggio dei fusibili

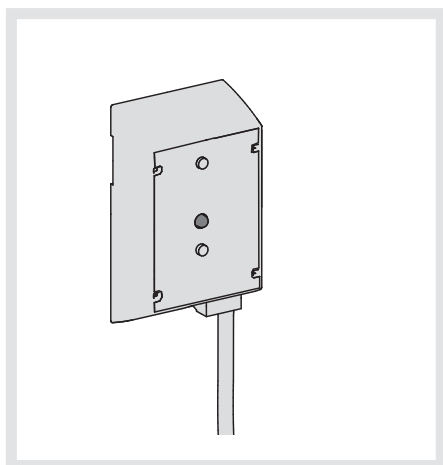

Nur Sicherungseinsätze mit spannungsführenden Griffflaschen verwenden!

Nach Betriebsnahme Prüftaste drücken!



Use only fuse links with metallic alive grip lugs!

Press test button after startup!



N'utilisez que des cartouches à couteaux avec pattes d'extraction sous tension!

Après la mise en service, appuyer sur la touche de contrôle!



Utilizzare solo fusibili con alette di estrazione sotto tensione

Dopo la messa in funzione premere il tasto di controllo!