

**coviva**  
**Smart wireless**  
**retrofit solutions**



**:hager**

# coviva

## wireless modules for easy retrofitting

When it comes to home retrofitting, less is more: No cabling and no plastering or painting means a quicker installation for you. And it's all possible thanks to coviva micro modules.

To build multipoint switching, dimming or centralisation, micro modules are the first step. Once installed behind existing or new switches they communicate wirelessly with each other without the need of a hub, to provide multiple functions throughout the home.



### Quick and easy installation.

Micro modules can be connected to any brand of existing switch and are ready to go. They control dimming, on/off switches, raise/lower functions and communicate with other modules without the need of a central hub.



### Universal controls

Each micro module can be linked to other modules, without any additional wiring and are fast and easy to program.



### Superior wireless reach

The micro modules are designed to deliver exceptional wireless reach. Indoors, they can cross through 2 concrete slabs and still transmit up to 30 metres. Outdoors, their range extends up to 100 metres in the open.



## Functions



Switch on / off



Dimming



Raise / lower



Timers

## Program



### Scenarios

to manage a combination of micro modules from the single push of a button. For example a 'going to bed' scenario could turn off all the lights, close the blinds or curtains and turn on the night light in the children's bedroom.

## Control



Lights



Blinds or motorized curtains



Garage doors



Gates



Automatic sprinkler



Air conditioning\*



Expansion

\*switch on / off function available. Check A/C control wiring.

# Pair the micro modules in a few easy steps

When developing coviva, we focused on creating a product that was easy to use and fast to install – for both you and your customers. Two modules can be linked together in less than 15 seconds and will work with both tactile press or standard on/off two-way switch mechanisms. The micro modules can be installed and configured in a few simple steps:



## 01 Remove the existing switch

Add our compact wireless micro modules to the back of the existing switch. For dimming functions and blinds, conventional switches should be replaced with push buttons.



## 02 Enter pairing mode on the transmitter

With the switch or push button connected to the transmitter module, enter the pairing mode by briefly pressing the configuration **cfg** button.







































## 03 Press the switch at the plate

Press the connected switch or push button. (A signal is sent).

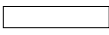
## 04

### Function LED colourmodule

LED colour	Switch module	Dimming module	Shutter / Blinds module
	<b>on/off</b> ON / OFF, Toggle switch	 ON / OFF, Variation +/-	 Up / stop TRM692AU only
	<b>on</b> ON	 ON, variation +	 Up, stop
	<b>off</b> OFF	 OFF, variation -	 Down, stop
	 1 Scenario 1	 1 Scenario 1	 1 Scenario 1
	 2 Scenario 2	 2 Scenario 2	 2 Scenario 2
	 Timer	 Timer	 Down / stop
	 ON / OFF (light switch)	 ON / OFF (light switch)	 Shutters command (light switch)
	<b>on</b>  Force ON*		  Force Up
	<b>off</b>  Force OFF*		  Force Down
	 Erase	 Erase	 Erase

\* functions only available on these products

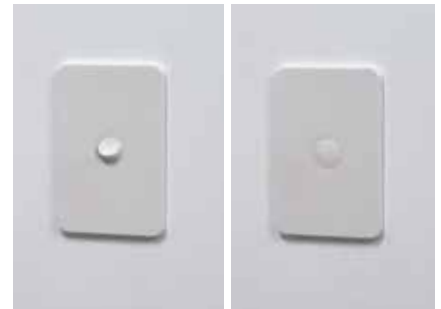

## 04

### Select the function on the receiver

Select the function (colour of the LED as per table above) on the receiver that you wish to control by briefly pressing the function **fct** button. Validate your choice by holding in the function **fct** button > 2s until the LED flashes.

## 05

### Exit the pairing mode on the transmitter

Exit the pairing mode by briefly pressing the configuration **cfg** button on the original transmitter module from step 1.

## 06

### Re-install the switch

Re-fit the switch plate to the wall.

# Control the lights from your headboard

Forgot to turn off the ceiling light before getting into bed? You can lie down and manage everything from your headboard ...

## Advantages

- turns lights off and on from the comfort of your bed,
- have as many switches as you need,
- works with any mechanical switch you may have.

## Want more comfort?

- control the blinds from the bed,
- control the lighting and blinds in the children's rooms,
- create a scenario controlling the lighting and blinds of any room.



# Add a switch without cabling

## Before

a simple switch at the entrance to the room.

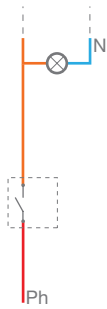
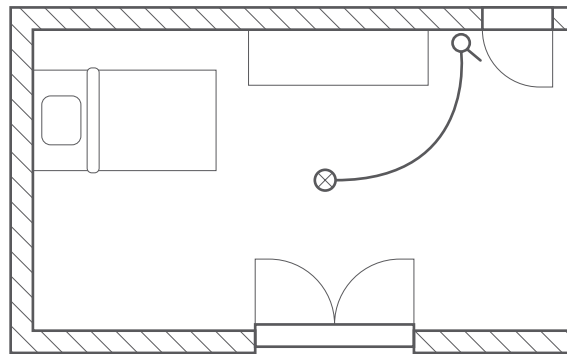

## After

2 way switching between the entrance and the headboard.

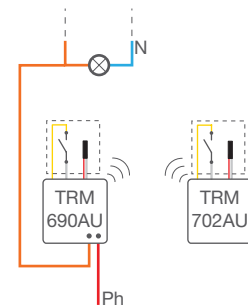
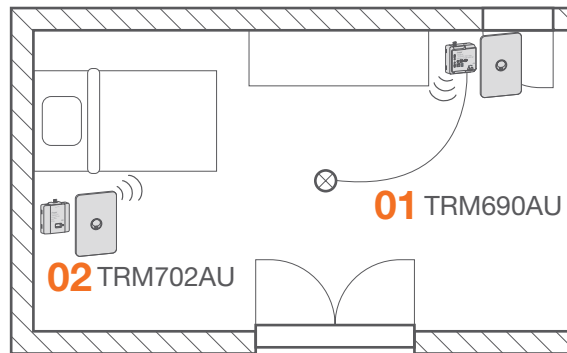

## Installing products

### 01

Add the micro module TRM690AU behind the existing switch:

- connect the “ceiling lamp” active and switchwire,
- connect input 1 to the existing switch.

### 02

Add a second point of control with the micro module TRM702AU behind a new switch and location of your choice:

- connect input 1 to the new switch.

## Pairing products

Pair the micro modules as per steps on page 4 & 5.

Input	Output to associate	Choice of function	Fct LED Colour code
Switch for lighting	TRM690AU	on off ON/OFF (Toggle switch)	

# Dim the lighting in the dining room from several points

When we receive our guests,  
it's always nice to create a  
friendly and warm atmosphere.

## Advantages

- choose the light intensity of the room,
- multiply the number of control points as you want,
- install without additional wiring or replastering.

## Want more comfort?

- control the shutters,
- control all the lighting from the entrance,
- create a scenario controlling the lighting and blinds in the dining room.



# Add dimmer switches to more locations

## Before

a simple switch at the entrance of the living room.

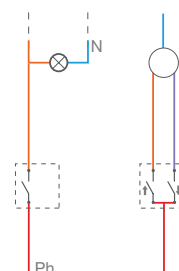
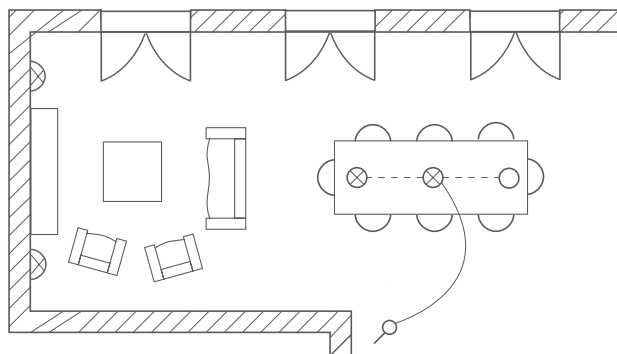

## After

2 way dimming between living room and dining room.

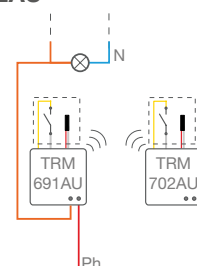
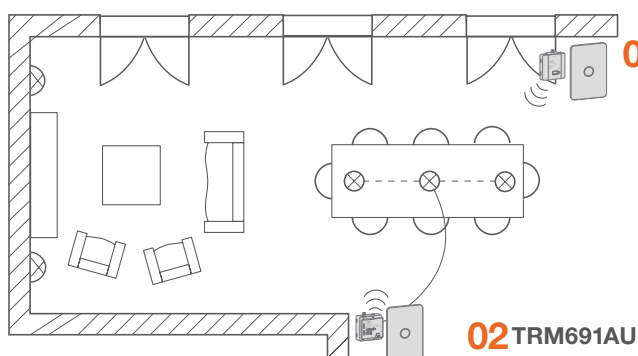

## Installing products

### 01

For dimming it is necessary to replace the existing switch with a push button of your choice. The micro dimmer module can not be controlled by a 2 way switch.

### 02

Add the micro dimmer module TRM691AU behind the push button:

- connect the "ceiling lamp" switchwire and the active
- connect input 1 to the push button.

### 03

Add the micro module TRM702A behind the newly located push button of your choice:

- connect input 1 to the push button.

## Pairing products

Pair the micro modules as per steps on page 4 & 5.

Input	Output to associate	Choice of function	Fct LED Colour code
Dimmer for lighting	TRM691AU	ON / OFF, Variation +/-	

# Open and close all the blinds from a single switch

Isn't it tedious closing all the blinds  
in the living room one after the  
other before going to bed?

## Advantages

- avoid unnecessary travel,
- adjust the sunlight according to your activities (TV, reading ...),
- control the level of all blinds equally from one push button.

## Want more comfort?

- add additional switches for individual control,
- centralize the blinds in a single zone (floor, set of rooms, ...),
- create a scenario controlling the lighting and blinds in the living room from a single push button.



# Centralise blind control without cabling

## Before

3 individual controls for blinds.

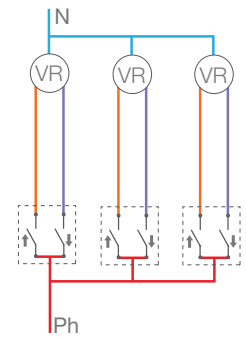
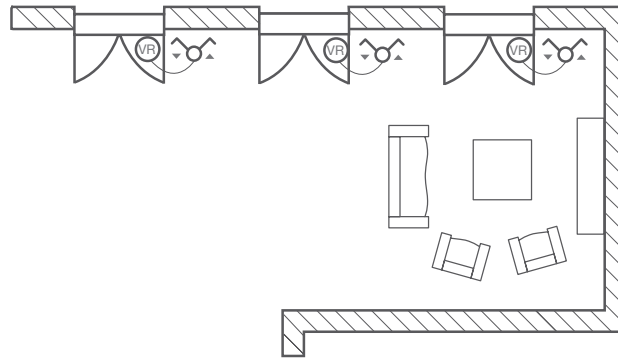

## After

3 individual controls and 1 centralized control for blinds.

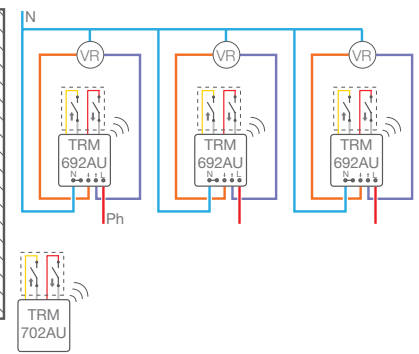
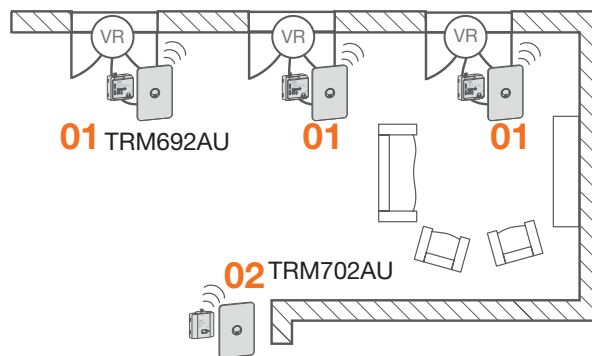

## Installing products

### 01

Add the TRM692AU micro modules behind each individual blind switch.

- connect phase, neutral \* and 1 / ↓
- connect input 1 (up) and input 2 (down) to the existing double switch.

\* To avoid removing the neutral behind the switchgear, it is possible to install the micro module in the blinds junction box often placed next to it. The inputs can be connected up to 10m.

### 02

Add the micro module TRM702AU and a push button in your new location:

- connect input 1 of TRM702AU to the push button.

## Pairing products

Pair the TRM702AU with all of the TRM692AU modules as per pages 4 & 5.

Input	Output		
	Output to associate	Choice of function	Fct LED Colour code
Push button No. 1 - rise of the blind	TRM692AU	▲ Up, stop	<span style="background-color: green; width: 20px; height: 10px; display: inline-block;"></span>
Push button No. 2 - lowering the blind	TRM692AU	▼ Down, stop	<span style="background-color: red; width: 20px; height: 10px; display: inline-block;"></span>

The inputs of the TRM692AU are pre-paired to operate with switches (In1 = up, In2 = down) and to control the connected awning.

# Retract the awning & turn on the lights when night falls

You will not miss a moment with friends to retract the awning and turn on the light ... Control all functions from the same switch.

## Advantages

- benefit from outside control,
- locate control where it is most convenient.

## Want more comfort?

- add an external waterproof control point,
- create a scenario controlling the exterior lighting and the blind,
- control the automatic watering of the garden.



# Multiple functions with one switch

## Before

a simple switch for outdoor lighting and 1 individual control of the blind.

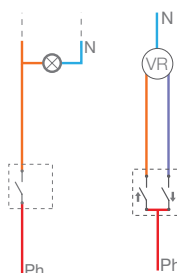
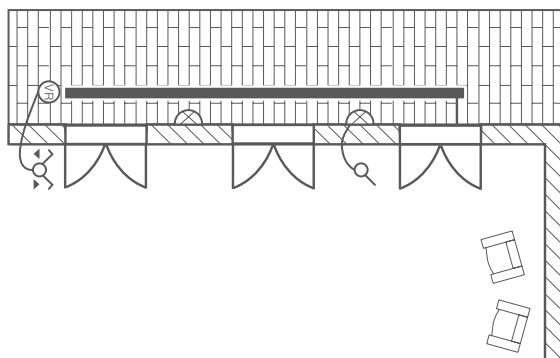

## After

a dual control for lights to turn on and awning to retract.

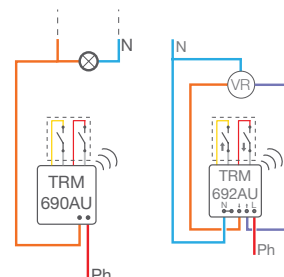
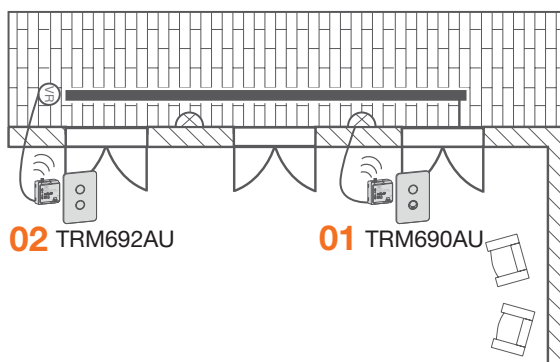

## Installing products

### 01

Add the micro module TRM690AU behind the existing light switch:

- connect the active and switchwire for the light
- connect input 1 to the existing switch.

### 02

Add the micro module TRM692AU behind the awning switchplate and connect the inputs to the push buttons.

To avoid removing the neutral, install the micro module in the junction box beside the blind. The entries can be connected up to 5m.

### 03

Add a second switch to the existing light switch.

- connect input 2 of the TRM690AU to the new switch.

## Pairing products

Pair the micro modules as per steps on page 4 & 5.

Input	Output to associate	Choice of function	Fct LED Colour code
Push button No. 1 - rise of the blind	TRM692AU	▲ Up, stop	
Push button No. 2 - lowering the blind	TRM692AU	▼ Down, stop	
Push button No. 3 - exterior lighting	TRM690AU	on/off ON/OFF (Toggle switch)	
Push button No. 4	Control a scenario: Turn on the lights and retract the awning		

The inputs of the TRM692AU are pre-paired to operate with switches (In1 = up, In2 = down) and to control the connected awning.



((RF))

**Features**

Robust and reliable, our micro modules are compatible with all mechanical switches and push buttons on the market. They enable switching, dimming and linked together wirelessly opening/closing systems to be controlled remotely making installation and additional switch points easy.

**TRM702AU**

Provides the possibility to put switches in almost any location.

**Programmable on/off**

- On/Off (switch)
- On
- Off
- On/Off (switch)
- On/Off dimming
- On dimming '+'
- Off, dimming '-'
- Timer
- Scene setting
- See data sheet for specific functions for each module type.

**Rolling shutter functions**

- Raise
- Lower
- Scene setting
- Raise / lower (switch)
- Force raise
- Force lower
- Repetition

**TRM693AU**

This module is particularly appropriate for any type of lighting control, including CFL and LED.



**Micro module 2 inputs, battery operated**

Description	Characteristics	Cat ref.	
Supply voltage:	3V DC	<b>TRM702AU</b>	
Battery:	Lithium powered CR 2430 3 V		
Battery Life used with push button:	5+ years (avg 10 operations / day)		
Battery life used with On/Off switch:	3+ years (avg 10 operations / day)		
Transmission frequency / Emission power:	433.05 - 434.79 MHz / 10mW		
Contact closure Min:	50ms		
Degree of Protection:	IP30		
Operating temperature:	-10°C → + 50°C		
Storage temperature:	- 25°C → + 70°C		
Receiver category / Transmitter duty cycle:	2 / <10%		
Inputs:	2		
Dimensions (HxLxD):	41 × 39.5 × 11 mm		
Provides 2 wireless switches when no existing wiring is available, to control / switch other micro modules when linked wirelessly.			



**Micro module - ON/OFF, no neutral required**

Description	Characteristics	Cat ref.
Supply voltage:	230V +10%/-15% 50Hz	<b>TRM690AU</b>
Product consumption:	100mW	
Transmission frequency / Emission power:	433.05 - 434.79 MHz / 10mW	
Max. switch rating:	200W (175 halogen via LVTx), 50W LED	
Contact closure Min:	50ms	
Degree of Protection:	IP20	
Operating altitude:	≤ 2000m	
Overvoltage category:	III	
Operating temperature:	-15°C → + 45°C	
Storage temperature:	- 25°C → + 70°C	
Receiver category / Transmitter duty cycle:	2 / <10%	
Inputs:	2	
Dimensions (HxLxD):	40 × 40 × 18 mm	



**Micro module - Dimming, no neutral (2 wire)**

Description	Characteristics	Cat ref.
Supply voltage:	230V +10%/-15% 50Hz	<b>TRM691AU</b>
Product consumption:	100mW	
Transmission frequency / Emission power:	433.05 - 434.79 MHz / 10mW	
Max. switch rating:	200W (175 halogen via LVTx), 50W LED	
Min rating:	10W (3W LED)	
Contact closure Min:	50ms	
Degree of Protection:	IP20	
Operating altitude:	≤ 2000m	
Overvoltage category:	III	
Operating temperature:	-15°C → + 45°C	
Storage temperature:	- 25°C → + 70°C	
Receiver category / Transmitter duty cycle:	2 / <10%	
Inputs:	2	
Dimensions (HxLxD):	40 × 40 × 18 mm	

### Micro module - ON/OFF, requires neutral

Description	Characteristics	Cat ref.
Supply voltage:	230V +10%/-15% 50Hz	<b>TRM693AU</b>
Product consumption:	100mW	
Transmission frequency / Emission power:	433.05 - 434.79 MHz / 10mW	
Max. switch current:	3A (230V Halogen 500W, LV Halogen 250VA) Fluoro & LED - 150W, Inductive - 3A cos $\Phi$ 0.6	
Degree of Protection:	IP20	
Switching capacity:	15 cycles per minute	
Pollution degree:	2	
Overvoltage category / surge:	III / 4kV	
Operating temperature:	-15°C → + 45°C	
Storage temperature:	- 25°C → + 70°C	
Receiver category / Transmitter duty cycle:	2 / <10%	
Inputs:	2 for potential-free contacts	
Dimensions (HxLxD):	40 × 40 × 18 mm	



### Micro module - Roller blind / shutter

Description	Characteristics	Cat ref.
Supply voltage:	230V +10%/-15% 50Hz	<b>TRM692AU</b>
Product consumption:	100mW (Max. 150mW)	
Transmission frequency / Emission power:	433.05 - 434.79 MHz / 10mW	
Delay between operating movements:	600ms	
Contact closure duration:	200ms	
Degree of Protection:	IP20	
Switching capacity:	3A cos $\Phi$ 0.6 / 15 cycles per minute	
Pollution degree:	2	
Overvoltage category / surge:	III / 4kV	
Operating temperature:	-15°C → + 45°C	
Storage temperature:	- 25°C → + 70°C	
Receiver category / Transmitter duty cycle:	2 / <10%	
Inputs:	2 for potential-free contacts	
Dimensions (HxLxD):	40 × 40 × 18 mm	



### Micro module - ON/OFF volt free contact, requires neutral

Description	Characteristics	Cat ref.
Supply voltage:	230V +10%/-15% 50Hz	<b>TRM694AU</b>
Product consumption:	150mW	
Transmission frequency / Emission power:	433.05 - 434.79 MHz / 10mW	
Max. switch current:	AC1 - 4A	
Inductive DC load:	4A@12V DC 2A@24V DC Halogen 600W, LV Halogen 600VA Inductive - 4A cos $\Phi$ 0.6 , Fluoro 40W	
Degree of Protection:	IP20	
Switching capacity:	20 cycles per minute	
Overvoltage category / surge:	III / 4kV	
Operating temperature:	-15°C → + 45°C	
Storage temperature:	- 25°C → + 70°C	
Receiver category / Transmitter duty cycle:	2 / <10%	
Inputs:	2 for potential-free contacts	
Dimensions (HxLxD):	40 × 40 × 20 mm	



### Micro module - Pulse contact

Description	Characteristics	Cat ref.
Supply voltage:	230V +10%/-15% 50Hz	<b>TRM600AU</b>
Product consumption:	100mW (max. 150mW)	
Transmission frequency / Emission power:	433.05 - 434.79 MHz / 10mW	
Max. switch current:	0.5A	
Contact closure duration:	200ms	
Degree of Protection:	IP30	
Operating altitude:	≤ 2000m	
Overvoltage category:	III	
Operating temperature:	-10°C → + 50°C	
Storage temperature:	- 25°C → + 70°C	
Receiver category / Transmitter duty cycle:	2 / <10%	
Inputs:	None	
Dimensions (HxLxD):	40 × 40 × 18 mm	



# coviva the connected house

Access new opportunities





# coviva

## new ideas for your home

When using a coviva smart box, you can easily connect your installations to the outside world and take control with your smartphone, tablet, computer or voice controlled smart speaker.



### Wireless micro modules

Micro modules transform existing electrical installations into an automated home without any construction work. When associated with a smartbox the modules can be controlled by smart devices from anywhere in the world.



### Smart connections

Use your smart phone or tablet, to control the lighting, blinds and scenarios while not at home via Google, Alexa or coviva apps.





## Voice command

By connecting to a Google Home® or Amazon Echo® device, lights and blinds can be controlled by voice command to any room in the home.



## Connected objects

Such as Tado® Thermostat / AC controller

**coviva**  
**smartbox**

# Smart configuration. Connect. Register. Done!

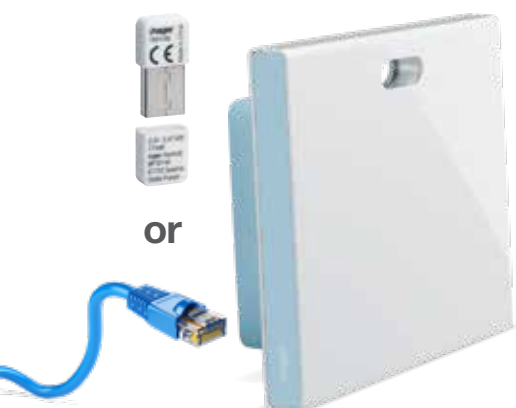

**01**

## Connect to the router

Connect the coviva smartbox to the Internet router with a cable or by Wi-fi using the coviva USB stick.

**02**

## Activate the smartbox

Register at hager.com to create a MyHager account and activate your coviva smartbox.

**03**

## Link the devices

Register your micro modules on the coviva smartbox.

Thanks to our quicklink wireless solution, coviva can be installed without any of the routing required by a hard-wired solution. And configuring the coviva smartbox couldn't be easier.



**04**

### Transfer to the customer

Transfer the configured system to your customer with a simple touch of a button. Your customer will then receive an e-mail notification.



**05**

### Customer activates their account

Your customer will use a link in the email to register at MyHager and activate the box in their name.

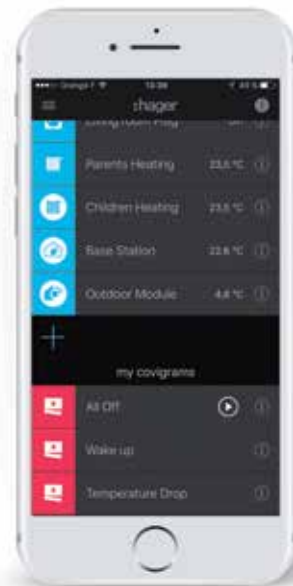

**06**

### Control via app

All devices will be displayed on the coviva app or simply can be found via Google or Amazon Alexa apps under coviva skills.

### Good to know

If necessary, your customers can grant you access to their smartbox any time in the future. That way, you can register new devices or expand their smart home.

# Wherever you go, take your smart home with you.

With the coviva app, you can control your lights, blinds and other home systems anywhere, anytime. Plus, you can create your own personalized scenarios and rules to perfectly suit your needs.



## In harmony with your lifestyle

Want to unwind after a long day?  
Programme a coviva scenario to dim down the lights and close the blinds before you get home.

## Morning jog? Not if it's raining!

The coviva smartbox interacts with connected objects such as the Netatmo Weather Station<sup>®</sup> to make your life more comfortable. For example, why not create a coviva program that wakes you up for a jog by gradually turning on the lights and raising the blinds – but only if it's dry outside?



## Complete data security

All data is stored on the local smartbox and can only be accessed by users. Remote access is possible through an encrypted service. Electricians and administrators require a personalised MyHager account to access any features directly.



**Android or Apple**  
On smartphone, tablet or computer – the coviva app is available for all mobile devices using Android or Apple operating systems.

### coviva smartbox features

- coviva smartbox, adapter plate for optional wall mounting, RJ45 connection cable Cat.5e, power supply unit 230 V AC/5 V DC
- for visualising and controlling quicklink installations via an app.
- for Apple and Android smartphones
- coviva smartbox can only be commissioned with a myHager account as a registered electrician
- with 3 LEDs on the rear side (operation, WLAN and online) and one status RGB LED in the upper recess

### USB stick for coviva Features

- USB stick can be inserted to the side or rear of the coviva smartbox, depending on the installation
- WLAN connection of the coviva smartbox is possible with the USB stick TKH180

### coviva smartbox

Description	Characteristics	Cat ref.
Operating voltage:	5V	<b>TKP100AU</b>
Power consumption:	< 3W	
Emission power:	10mW	
Transmission frequency:	433.05 - 434.79MHz	
Transmitter duty cycle:	< 10%	
Receiver category:	2	
Wireless range (open air):	> 300 m	
Network connection:	Ethernet LAN at least Cat. 5e-shielded	
Network connection WLAN (optional):	802.11 b/g/n	
USB port (only suitable for TKH180):	5V / 250mA max. Only for connection of Hager devices Do not use for charging!	
Protection class, protection type:	II, IP30/IK04	
Operating temp.:	0...40°C	
Storage temp.:	-25...+70°C	
Relative humidity without condensation:	93% at 40°C	
Installation altitude:	≤ 2000m	
Dimensions (W x H x D):	178.5 x 156 x 48.4 mm	
<b>Power supply</b>	<b>TKC110</b>	
Operating voltage:	230V~	
Frequency:	50/60Hz	
Output:	5V, max. 3A	



### USB Wi-fi dongle for coviva

Description	Characteristics	Cat ref.
Operating frequency:	2.41 - 2.47GHz	<b>TKH180</b>
Emission power:	17mW	
Standards:	IEEE 802.11 b/g/n	
Operating voltage:	5V s 10%	
Operating current:	<110mA at 5V s input	
Current consumption:	max. 250mA	
USB interface:	USB 2.0	
Operating temperature:	0°C to +50°C	





**Hager Electro Pty Ltd**  
1/170 Power Street  
Glendenning NSW 2761

Phone: 1300 850 253  
Fax: 1300 424 372  
customerservice@hagerelectro.com.au  
**hagerelectro.com.au**

**DISCLAIMER:** Whilst every effort has been made to ensure the reliability of the information is correct at time of publication, Hager cannot guarantee the accuracy of all of the information contained herein. Changes/updates brought to the attention of Hager, once verified, will be corrected in future editions.