

6LE008159A  
8PSS5980-0AA01-5AA8.00

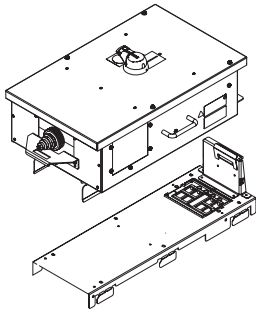

- (DE) Montageanleitung
- (GB) Assembly instructions
- (NL) Montagehandleiding
- (SE) Monteringsanvisning
- (PL) Instrukcja montażu

KEB734xxx, KEB735xxx

- (DE) Leer-Abgangskasten Größe 4/ 5 für MCCB
- (GB) Empty tap-off box, size 4/ 5, for MCCB
- (NL) Lege aftakkast grootte 4/ 5 voor MCCB
- (SE) Tom uttagslåda storlek 4/ 5 med MCCB
- (PL) Pusta skrzynka odpywowa, rozmiar 4/ 5, na MCCB

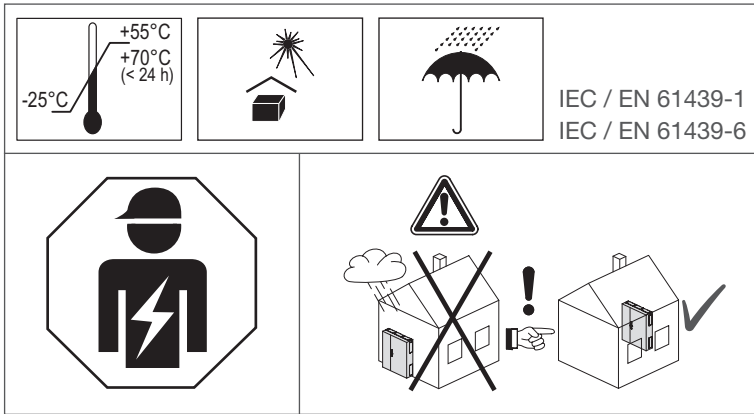

## (GB) Safety Information!



Electrical devices may only be installed and assembled by a qualified electrician in accordance with the relevant installation standards, guidelines, regulations, directives, safety and accident prevention regulations of the country.

Always comply with the warning information on the device!

Observe the mounting instructions of the installed devices.

In particular, carry out appropriate maintenance measures.

Secondary cables may not be routed in the areas of the blow-out spaces of the circuit breakers.

The tap-off box may not be used to supply energy into the busbar system (IEC 61439-6).

Failure to comply with these installation instructions may result in damage to the device, fire or other hazards.

These instructions are an integral component of the product and must be retained by the end user.



### DANGER!

Electric shock when live parts are touched!  
An electric shock can lead to death!

- Isolate all connection cables before working on the device and cover any live parts in the area!

## (DE) Sicherheitshinweis!



Einbau und Montage elektrischer Geräte dürfen nur durch eine Elektrofachkraft gemäß den einschlägigen Installationsnormen, Richtlinien, Bestimmungen, Sicherheits- und Unfallverhütungsvorschriften des Landes erfolgen.

Warnhinweise auf dem Gerät sind unbedingt zu beachten!

Die Montageanleitungen der eingebauten Geräte sind zu beachten.

Insbesondere sind entsprechende Wartungsmaßnahmen durchzuführen.

Sekundärleitungen dürfen nicht in den Bereichen der Ausblasräume der Leistungsschalter verlegt werden.

Der Abgangskasten darf nicht zur Einspeisung von Energie in das Stromschienensystem genutzt werden (IEC 61439-6).

Bei Nichtbeachten der Installationshinweise können Schäden am Gerät, Brand oder andere Gefahren entstehen.

Diese Anleitung ist Bestandteil des Produktes und muss beim Endkunden verbleiben.



### GEFAHR!

Elektrischer Schlag bei Berühren spannungsführender Teile!  
Elektrischer Schlag kann zum Tod führen!

- Vor Arbeiten am Gerät Anschlussleitungen freischalten und spannungsführende Teile in der Umgebung abdecken!

## (NL) Veiligheidsinstructie!



Inbouw en montage van elektrische apparatuur mag alleen door een installateur worden uitgevoerd conform de geldende installatienormen, richtlijnen, voorschriften, bepalingen en ongevalpreventievoorschriften van het betreffende land.

De waarschuwingen op het apparaat moeten absoluut worden aangehouden!

De montagehandleidingen van de ingebouwde apparaten moeten worden aangehouden.

Met name moeten de bijbehorende onderhoudsmaatregelen worden uitgevoerd.

Secundaire leidingen mogen niet in de omgeving van de uitblaasruimte van de installatieautomaat worden geïnstalleerd.

De aftakkast mag niet voor de voeding van energie in het railkokersysteem worden gebruikt (IEC 61439-6).

Bij het niet naleven van de installatie-instructies kan schade aan het apparaat, brand of andere gevaren optreden.

Deze handleiding maakt deel uit van het product en dient in het bezit van de eindgebruiker te blijven.



### GEVAAR!

Gevaar voor elektrische schok bij aanraking van spanningvoerende delen!  
Elektrische schokken kunnen de dood tot gevolg hebben!

- Voorafgaand aan werkzaamheden aan het apparaat de aansluitleidingen loskoppelen en spanningvoerende delen in de omgeving afdekken!

## SE Säkerhetsanvisningar!

Inbyggnad och montering av elektriska enheter får endast utföras av en behörig elektriker i enlighet med de gällande nationella installationsnormerna, riktlinjerna, bestämmelserna, säkerhets- och olycksfallsförebyggande föreskrifterna.

Varningar på enheten måste ovillkorligen följas!

De inbyggda enheternas monteringsanvisningar måste följas.

I synnerhet måste de aktuella underhållsåtgärderna genomföras.

Sekundärledning får inte dras i närheten av dvärgbrytarnas utblåsutrymmen.

Uttagsslåda får inte användas för inmatning av energi i strömskenssystemet (IEC 61439-6).

Kan medföra allvarliga kroppsskador, eldsvåda eller materiella skador. Läs och följ hela bruksanvisningen.

Denna anvisning betraktas som en produktkomponent och ska lämnas kvar hos slutkunden.



### FARA!

**Elektrisk stöt vid beröring av spänningsförande delar!  
Elektrisk stöt kan leda till döden!**

- Koppla från anslutningsledningar och täck över spänningsförande delar i omgivningen före arbeten på enheten!



## PL Wskazówka dotycząca bezpieczeństwa!



Zabudowy i montażu urządzeń elektrycznych może dokonać tylko wykwalifikowany instalator zgodnie z właściwymi dla danego kraju normami dot. instalacji, dyrektywami, warunkami i przepisami BHP.

Bezwzględnie przestrzegać wskazówek ostrzegawczych na urządzeniu!

Przestrzegać instrukcji montażu instalowanych urządzeń.

W szczególności dopilnować przeprowadzenia odpowiednich czynności konserwacyjnych.

Nie należy prowadzić przewodów wtórnych w obszarach komór przedmuchowych wyłącznika nadmiarowo-prądowego.

Skrzynka odpływowa nie może być wykorzystywana do zasilania energetycznego systemów szyn prądowych (IEC 61439-6).

Nieprzestrzeganie wskazówek dotyczących instalacji może doprowadzić do uszkodzenia urządzenia, pożaru lub innych niebezpieczeństw.

Niniejsza instrukcja jest częścią składową produktu i musi pozostać u klienta.



### NIEBEZPIECZEŃSTWO!

**Niebezpieczeństwo porażenia prądem przy dotknięciu elementów znajdujących się pod napięciem!  
Porażenie prądem grozi śmiercią!**

- Przed rozpoczęciem prac przy urządzeniu należy odłączyć przewody podłączające od sieci, a także osłonić sąsiednie elementy znajdujące się pod napięciem!

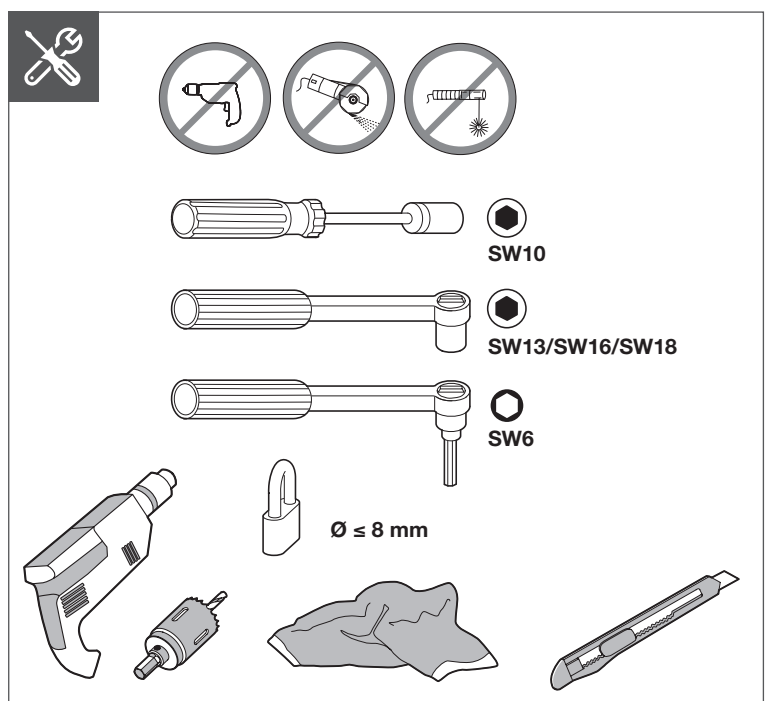
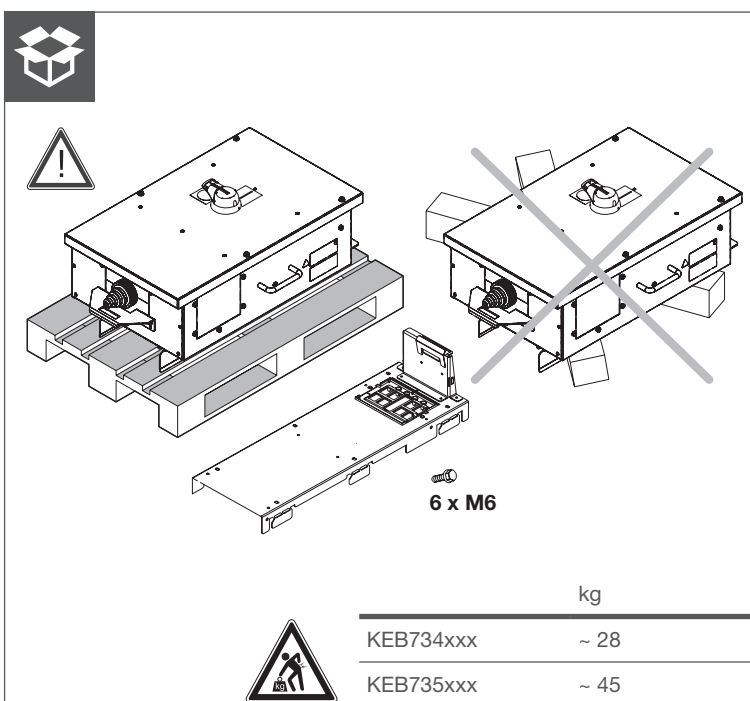

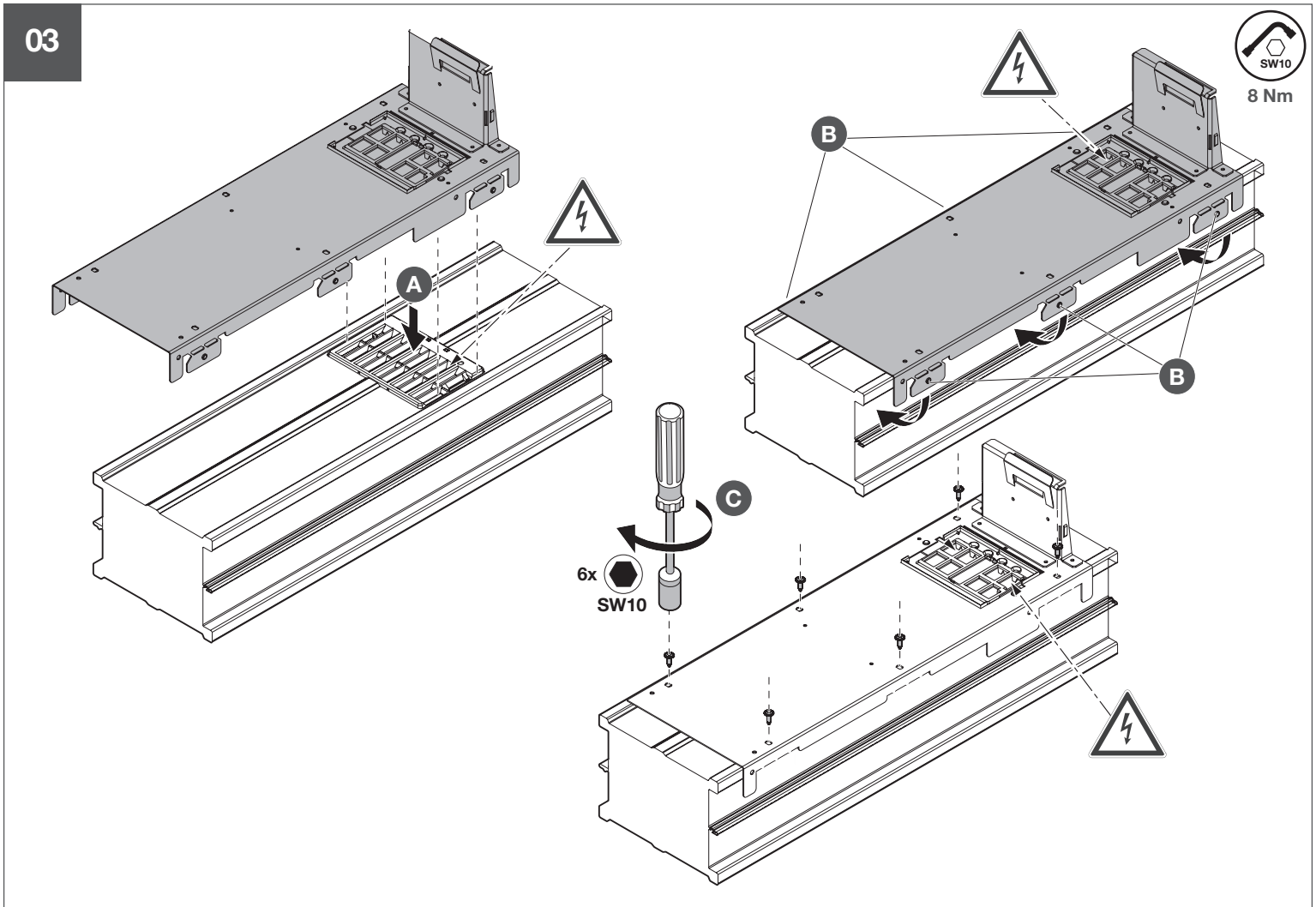
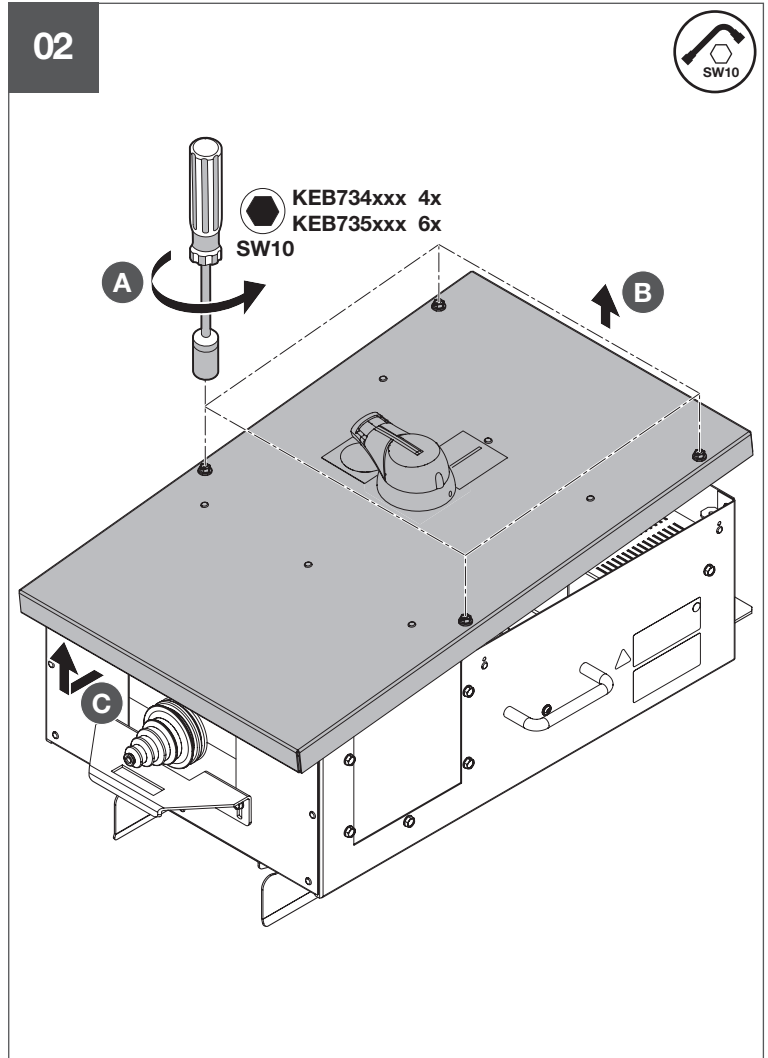
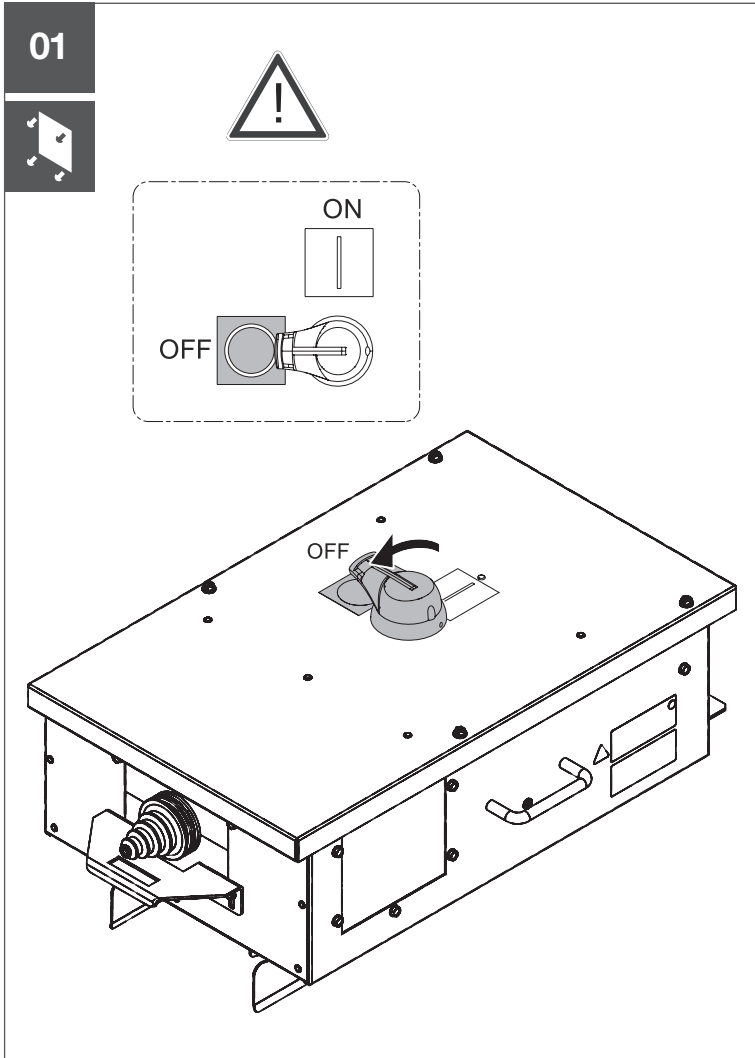



04

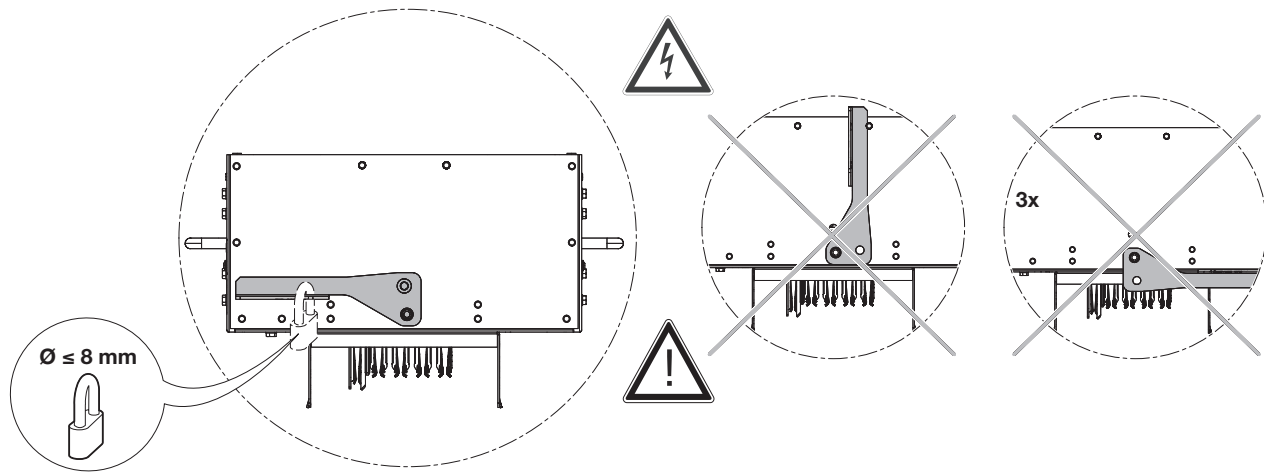

05

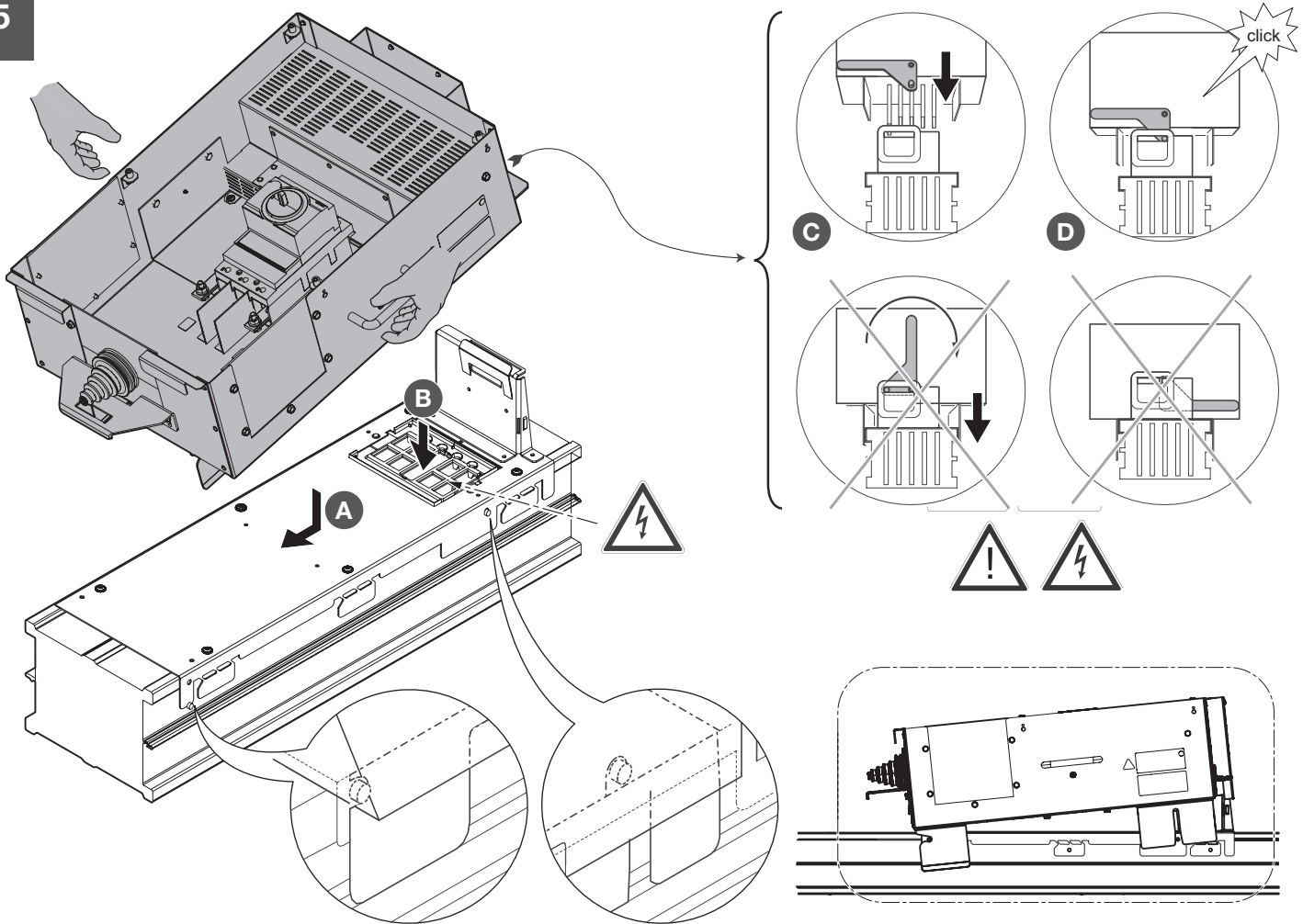

06a

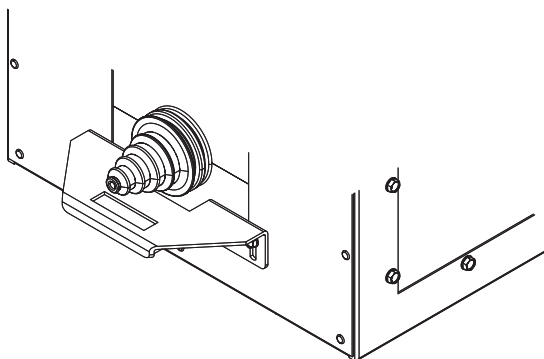

KEB734xxx

06b

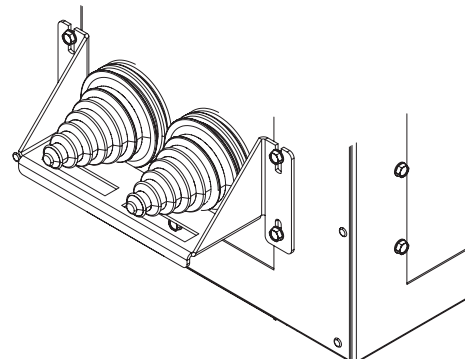

KEB735xxx





07

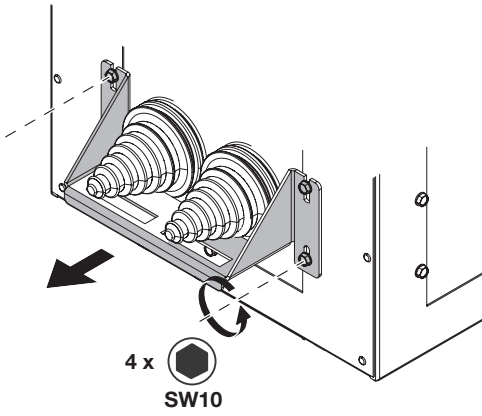

08

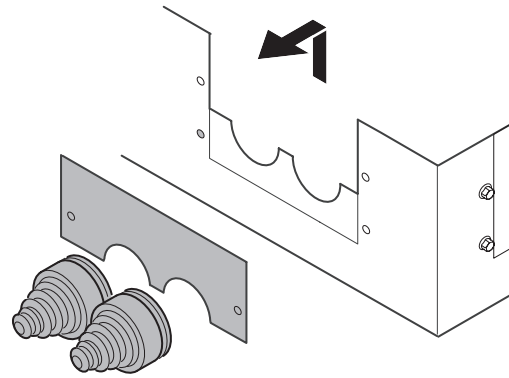

09

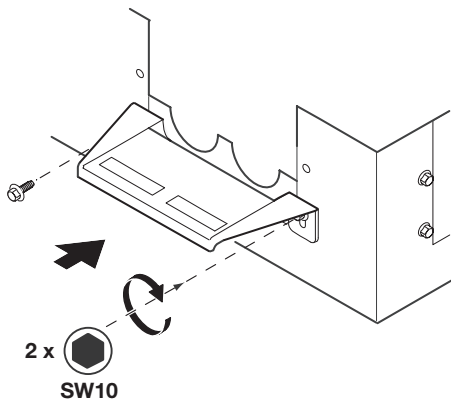

10

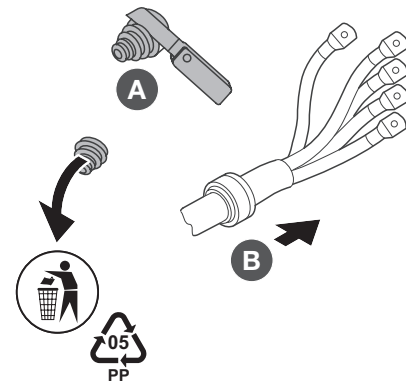

11

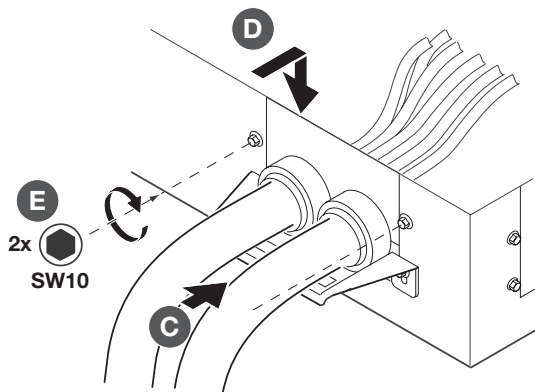

12

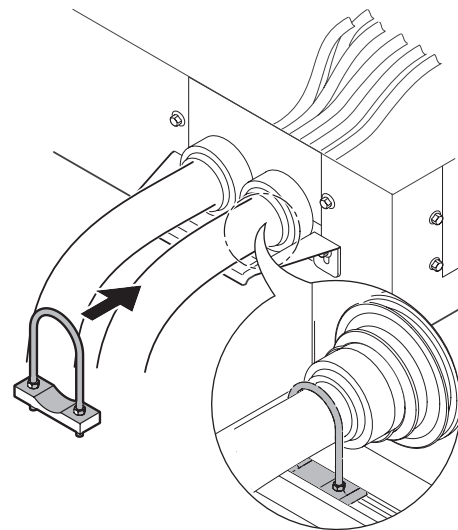



13

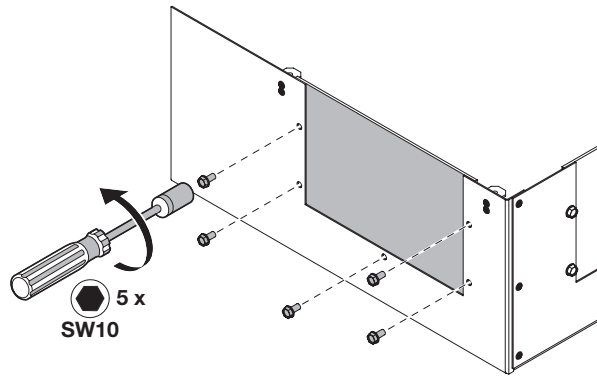

14

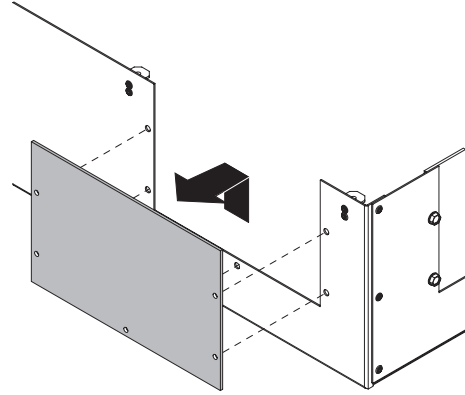

15

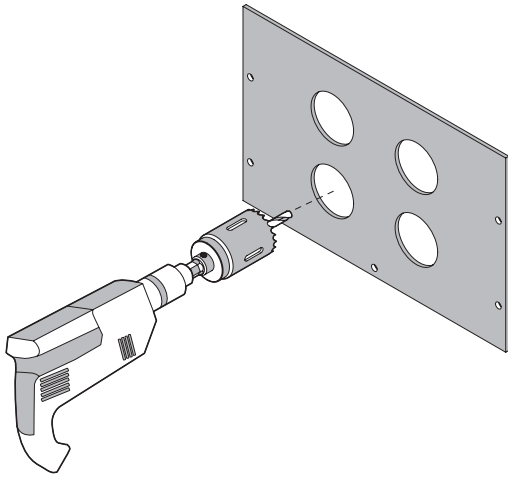

16

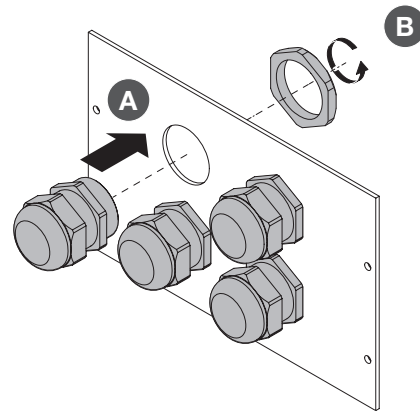

17



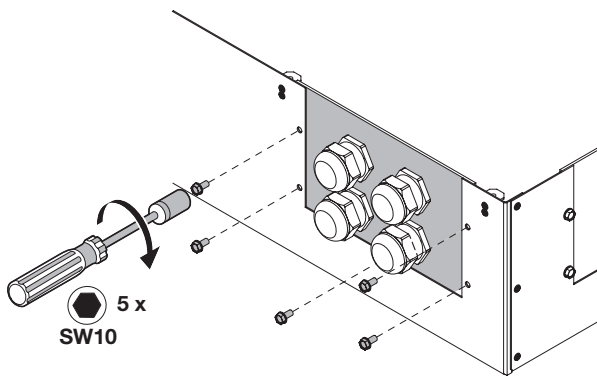

8 Nm

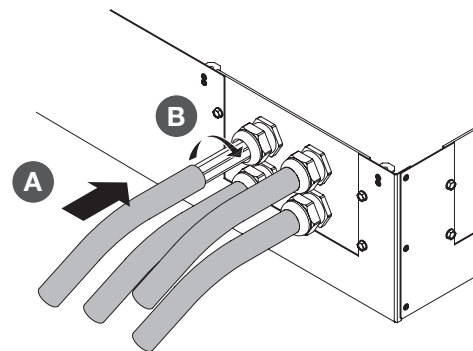

18

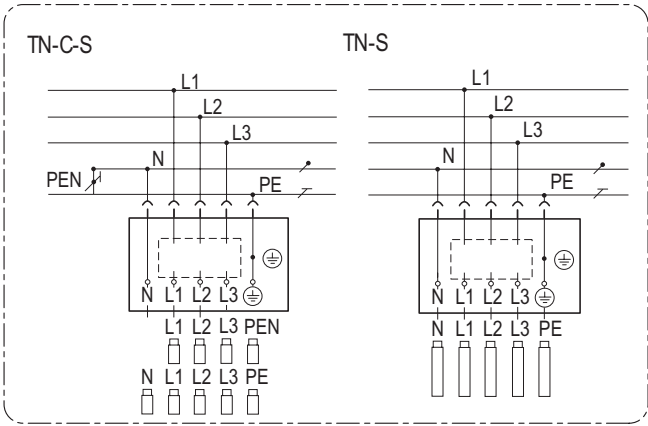
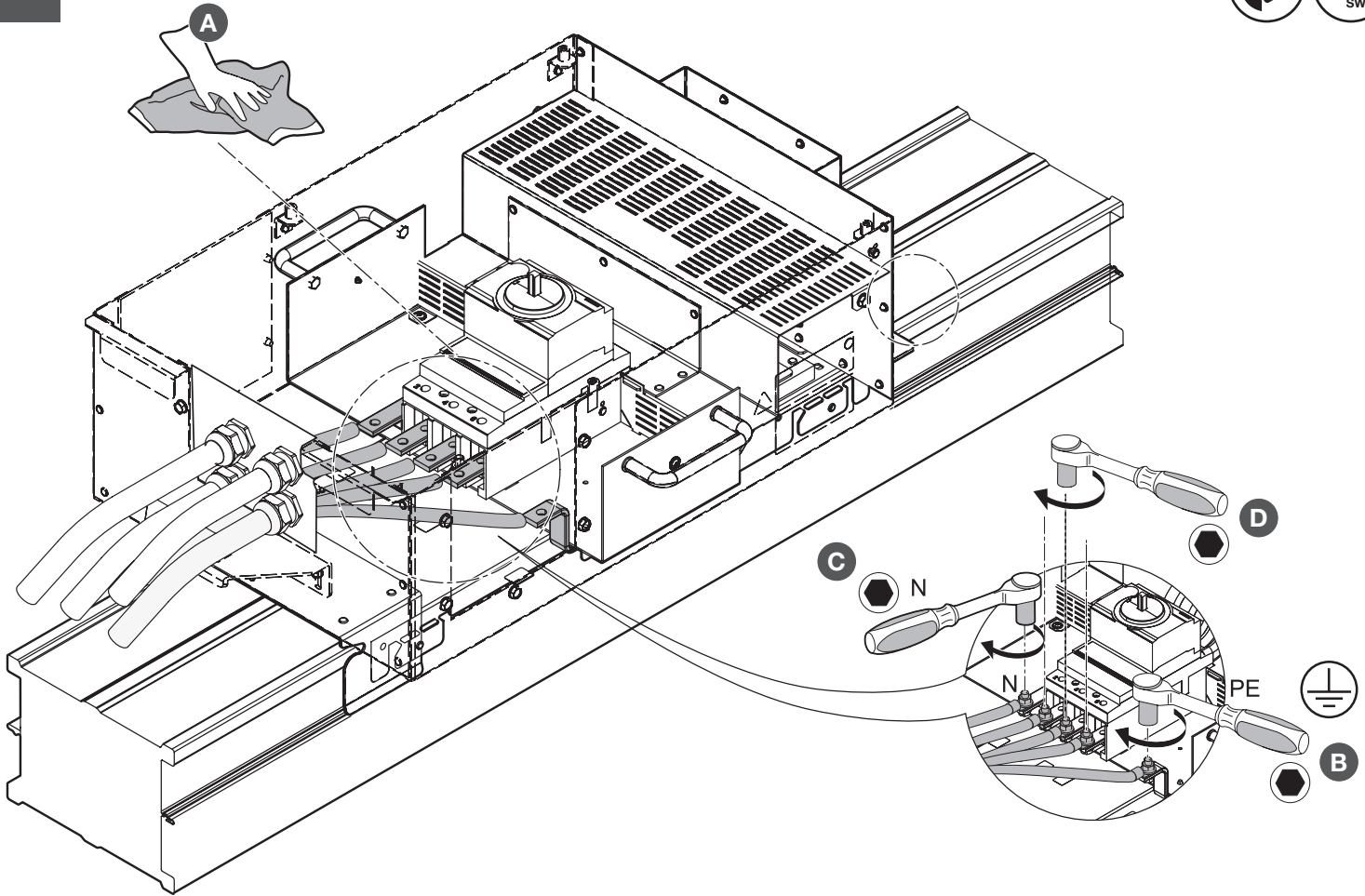



N-L1-L2-L3-PE		Nm
KEB734xxx	SW13 (M8)	20
KEB735xxx	SW16 (M10)	40

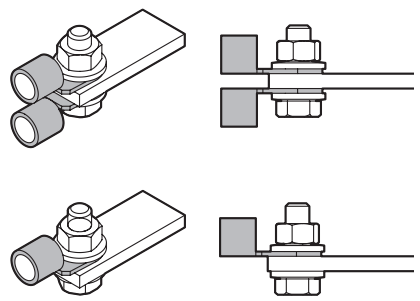
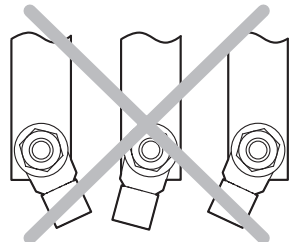
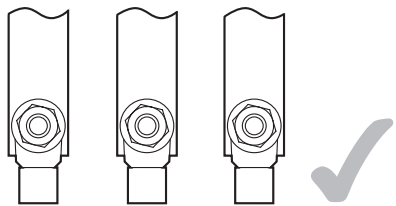

20

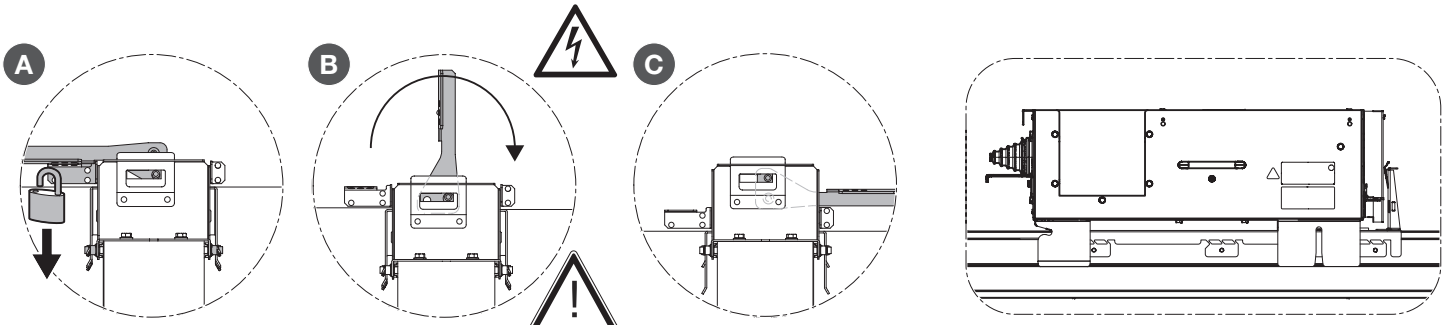
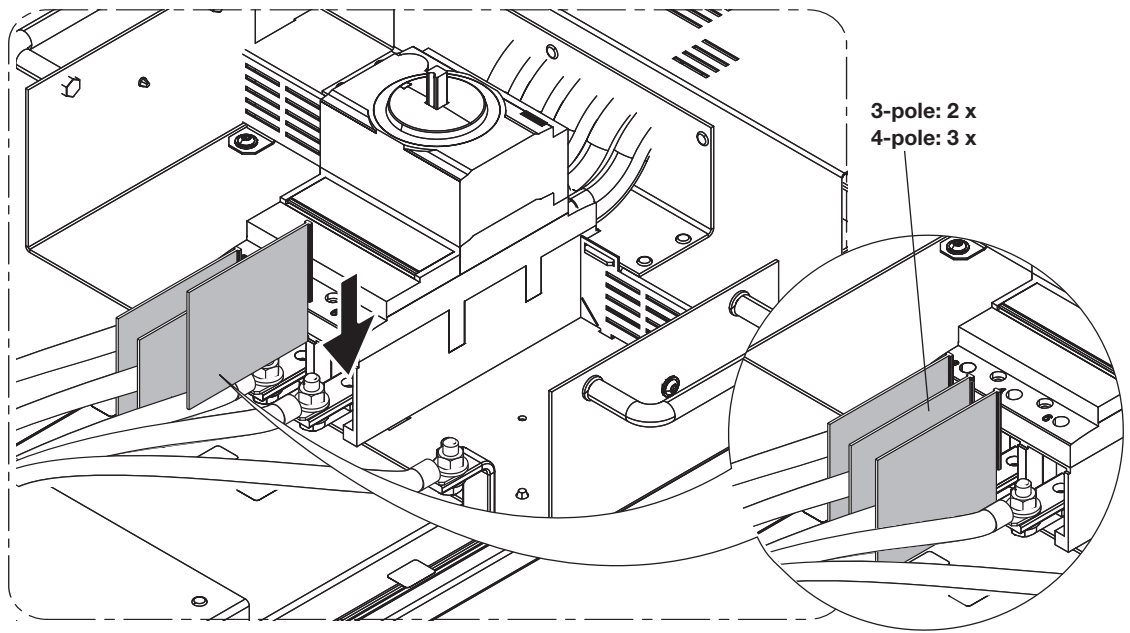

21

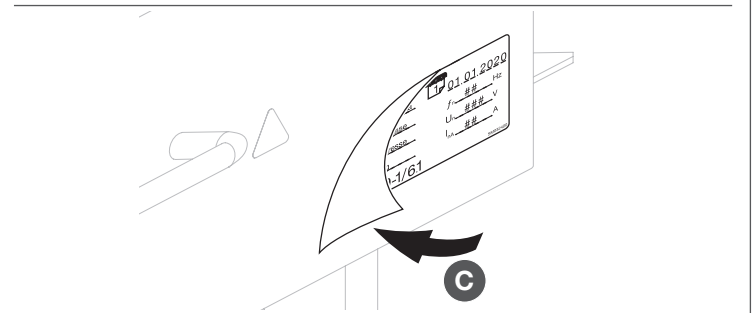
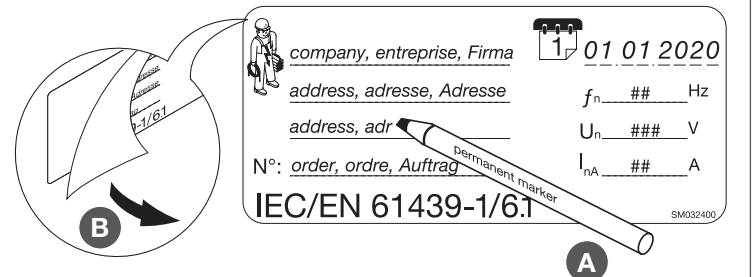
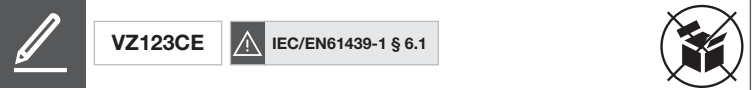
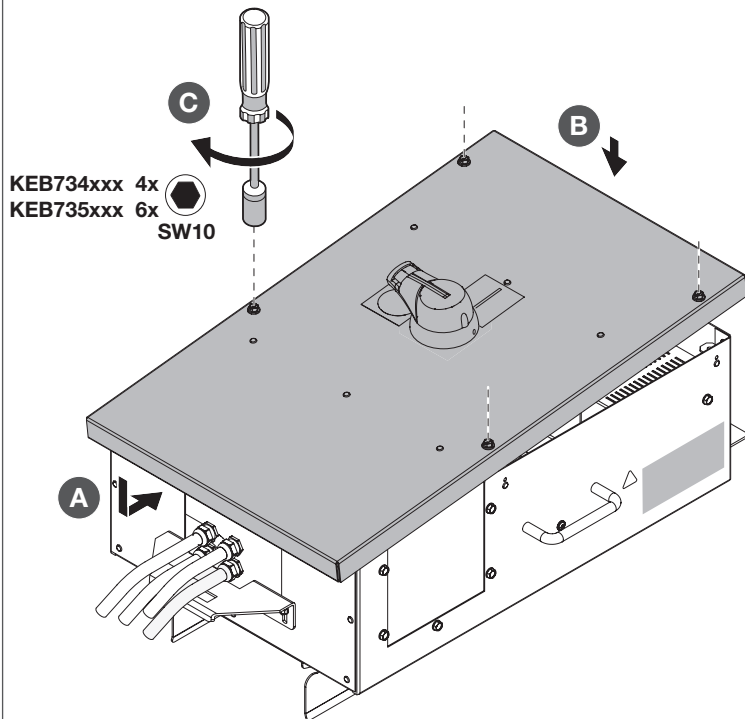

- ⚠ (GB) The Assembly (DBO) designated markings must be completed as specified in IEC/EN 61539 - 1 clause 6.1.
- ⚠ (DE) Die Schaltgerätekombination (DBO) muss mit den Aufschriften nach IEC/EN 61439-1 Abschnitt 6.1 gekennzeichnet werden.
- ⚠ (NL) De voor Assemblage (DBO) bestemde markeringen moeten ingevuld zoals gespecificeerd in IEC/EN 61439-3 paragraaf 6.1.
- ⚠ (SE) Kopplingsutrustningen måste märkas med etikett i enlighet med IEC / EN 61439-1 avsnitt 6.1.
- ⚠ (PL) Rozdzielnica musi być oznakowana zgodnie z IEC/EN 61439-1 rozdział 6.1.