

2D

REQ0..Y, REQ1..Y, REV11...Y,
REQ2..A

Audio door station 2-wire

Safety instructions

Electrical equipment may only be installed and assembled by a qualified electrician in accordance with the relevant installation standards, guidelines, regulations, directives, safety and accident prevention regulations of the country.

When installing and laying cables, always comply with the applicable regulations and standards for SELV electrical circuits.

These instructions are an integral component of the product and must be retained by the end user.

Design and layout of the device

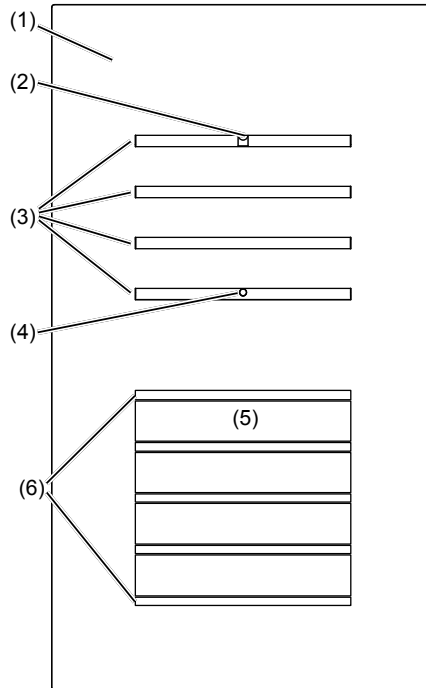

Figure 1: Design and layout of the device front

- (1) Front plate stainless steel
- (2) Microphone
- (3) Door loudspeaker
- (4) Twilight sensor for call button
- (5) Button panel with call push-buttons
- (6) Cover strip for dismantling protection

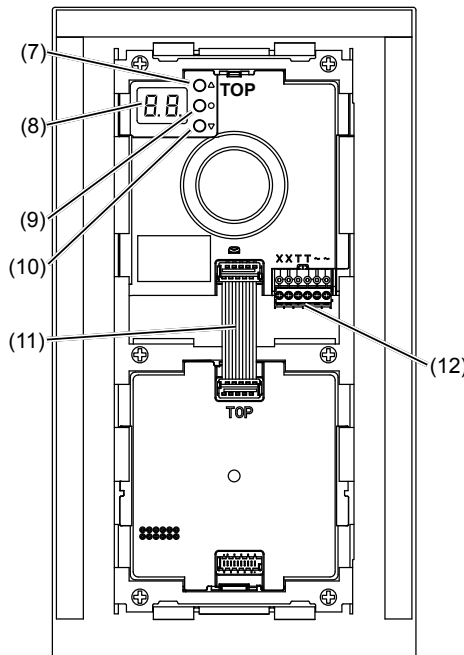

Figure 2: Design and layout of the device back

- (7) Adjustment button Upwards ▲
- (8) 7-segment display
- (9) Selection button ○
- (10) Adjustment button downwards ▼
- (11) Module bus connector
- (12) Connection terminal block

Function

The audio door station works in the 2-wire bus system and enables communication via sound.

Correct use

- for surface- or flush-mounted installation
- not compatible with intercom systems of other manufacturers
- suitable for use exterior applications

Product characteristics

- completely pre-assembled
- protected against vandalism
- with brushed 2 mm stainless steel front plate
- Name plate can be changed from the front without any special tools
- One-man commissioning
- call button with acknowledge tone (can be switched off) and tactile feedback
- call button, light release or door release can be adjusted even without any function
- durable, homogeneous, white LED call push-button backlighting
- Twilight controlled call push-button backlighting with adjustable switch-on brightness level
- opening of door station only with enclosed opening tool
- break-proof flush-mounted call buttons
- Loudspeaker and microphone protected against sabotage
- Volume and microphone sensitivity settable
- Door release contact on 1 ... 10 s adjustable
- Door release without previous call adjustable in single door systems
- Safety rope as installation aid

Operation

Establish call (ringing)

- Press the call push-button assigned to the desired subscriber.

If configured, the call push-button activation is confirmed by an acknowledge tone. Addressed indoor stations are called.

Switch-on lights

A call push-button is configured and labelled for lighting control (light insert supplied).

- Press the call push-button for lighting.

If configured, the call push-button activation is confirmed by an acknowledge tone. The light contact of a line power supply is closed for the set time.

Label call push-button

- Keep call push-button pressed on one side. On the opposite side, the lever opening (14) is accessible for a screwdriver.
- Position the screwdriver in the lever opening (13) and release the interlock (Figure 3).
- Remove cover with name plate insert.

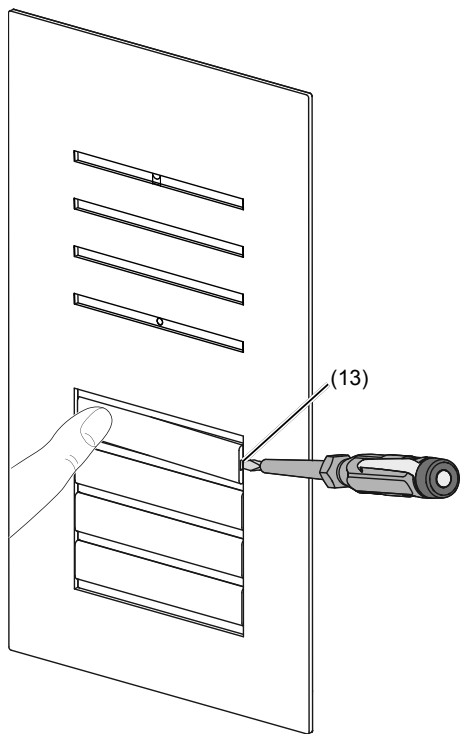

Figure 3: name plate change

(13) Lever opening

- Label name plate insert if required.
- Insert name plate insert, prepared foil or prepared labelling strip into the cover and press on cover.
- ⓘ Do not use any paper for the name plate insert, since moisture and UV light will damage the paper and labelling.
- ⓘ UV-resistant foil with laser printing is suitable for labelling as well as labelling devices for labelling strip:
 - small buttons - 12 mm
 - medium buttons - 30 mm

Door stations with status indication

Display	Cause	Function/Lighting duration
	A subscriber is called.	After 90 s without call acceptance or an operation on the door station, goes out.
	A subscriber accepts the door call.	goes out, lights up as long as the intercom connection is pressed down, max. 3 min.
	The door is unlocked.	Call not accepted: Symbol goes out and lights up for the unlocking time set on the door station. Call accepted: In addition to the , the lights up for the unlocking time set on the door station. goes out approx. 5 sec after the symbol.

Table 1: Status indications of door station

Cleaning and care

Commercially available products for stainless steel and car paintwork care containing a wax component for conservation are recommended for cleaning and care.

- ⓘ Do not use wire wool, wire brushes or any similar products for cleaning. This will prevent damage to the surface and accumulation of flash rust.

Information for electricians

Installation and electrical connection

⚠ DANGER!
 Touching live parts in the installation environment can result in an electric shock!
 An electric shock can be lethal!
 Before working on the device or load, disconnect all associated circuit breakers. Cover all live parts in the area!

When installing door communication systems, comply with the general safety regulations for telecommunications systems according to VDE 0800:

- Separate routing of power and door communication cables with a minimum spacing of 10 cm
- Partitions between power and door communication cables in shared cable ducts
- Use of standard telecommunications' cables, e. g. J-Y (St) Y with 0.8 mm diameter

Bus cables

- J-Y(ST)Y or A-2Y(L)2Y
Use wrapped wire pair.
Recommendation: white/yellow
- CAT
Use wrapped wire pair.
Recommendation: orange/white.

ⓘ **Avoid interference!**

- The 13-MHz video carrier frequency used for two-wire video door communication systems can cause reciprocal interference with other devices, such as radios, routers and WLAN devices.
- Only use shielded cables corresponding to the qualities recommended in this manual.
 - It is essential to comply with the applicable regulations during planning and installation.
 - Route cables, wire the devices, and in particular implement shielding and earthing measures as described below.

Mounting door station

Surface-mounted or flush-mounted housing is installed (see Assembly instruction housing). The connection cables and indoor stations are connected to the line power supply while taking the maximum cable lengths and attenuations into account (see operating instructions of the line power supply).

- The fastening elements supplied with the flush-mounted housing must be assembled with the nuts on the top and bottom on the threaded bolts. The support bracket (14) of the fastening elements must be located on the wall surface.

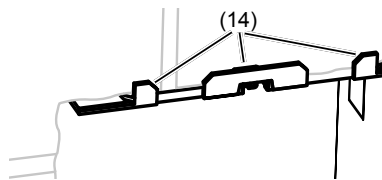

Figure 4: Support bracket of the fastening elements

(14) Support bracket of the fastening elements

- Insert opening tool (15) into the mounting device of the lower fastening element (16) on the housing (Figure 5).

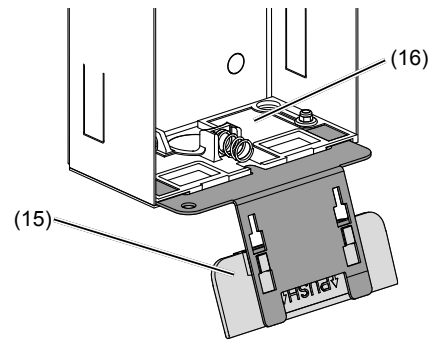

Figure 5: inserted opening tool

(15) Opening tool

(16) Fixing element

- Attach the loops of the safety rope (17) to the upper left suspension of the door station and to the upper fastening element (18) in the housing. Place the door station for installation onto the opening tool (Figure 5).

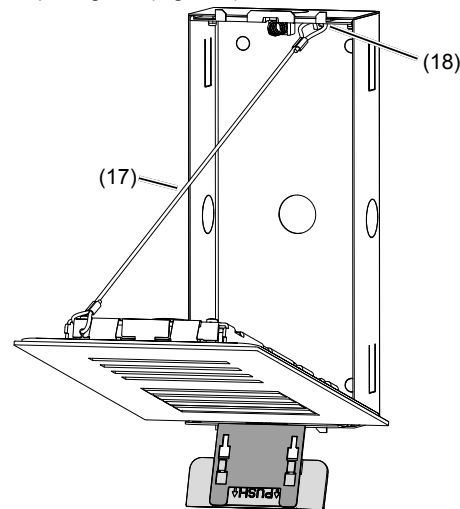

Figure 6: Installation position of door station

(17) Safety rope

(18) Upper fixing element

Connect door station

- Shorten connection cable of the door station as required and strip the required wires.
- Pull off connection terminal block (12) from the audio insert.
- Connect the 2-wire bus cable to the terminals **XX** of the connection terminal block (Figure 8).
- Connect door release to the terminals **TT** of the connection terminal block (figure 7 and 8) if required.

or:

- For manipulation-protected installation, connect the door release to the contact of the line power supply (Figure 9).

ⓘ The door release lead must not be inserted through the door station in order to protect against manipulation.

- For call push-button backlighting connect 12 V~ lead from the power transformer to the terminals **~** of the connection terminal block (Figure 7 - 9).

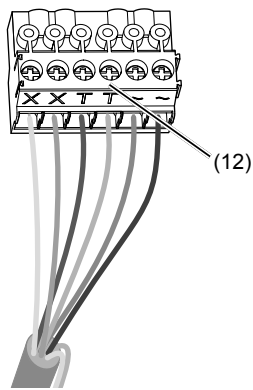

Figure 7: wired connection terminal block

- Information on the connection as a floor door station can be found in the operating instructions of the line power supply.
- Attach connection terminal block to audio insert.

Circuit symbols and elements of the circuit diagrams

- Line power supply RMD
- Power transformer
- Door release
- Door station audio
- Wrapped wire pair for 2D video devices (recommendation: white/yellow wire pair)
- Unwrapped wire pair, for e.g. for door release

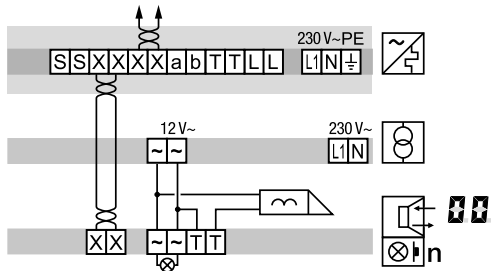

Figure 8: Door release connection on the door station

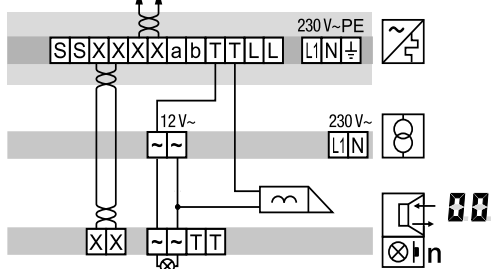

Figure 9: Connection of door station with manipulation-protected door release

If interference occurs in telecommunications systems, radio services or other systems during the operation of existing video door communication systems, measures for shielding and earthing the cables and for filtering must be implemented.

- For this purpose, connect all of the drain wires of the cables in a star shape using a terminal.
- Connect all drain wires to the PE rail in the distribution box.

Calling up and navigating system settings

On the back of the audio module, there are 3 buttons and a 2-digit 7-segment display (Figure 2, 7-10) for the system settings.

- Press ∇ / Δ button. Device turns to setting mode. The first menu entry **Ab** is displayed.
- The reading directions of the 7-segment display varies by 180° depending on which button ∇ / Δ you start with.

- Select the desired menu entry with ∇ / Δ (figure 10).
- Confirm the selection with \circ .
- The 7 segments display goes dark if there is no actuation for 5 seconds. Settings are applied. The device returns to normal operation.

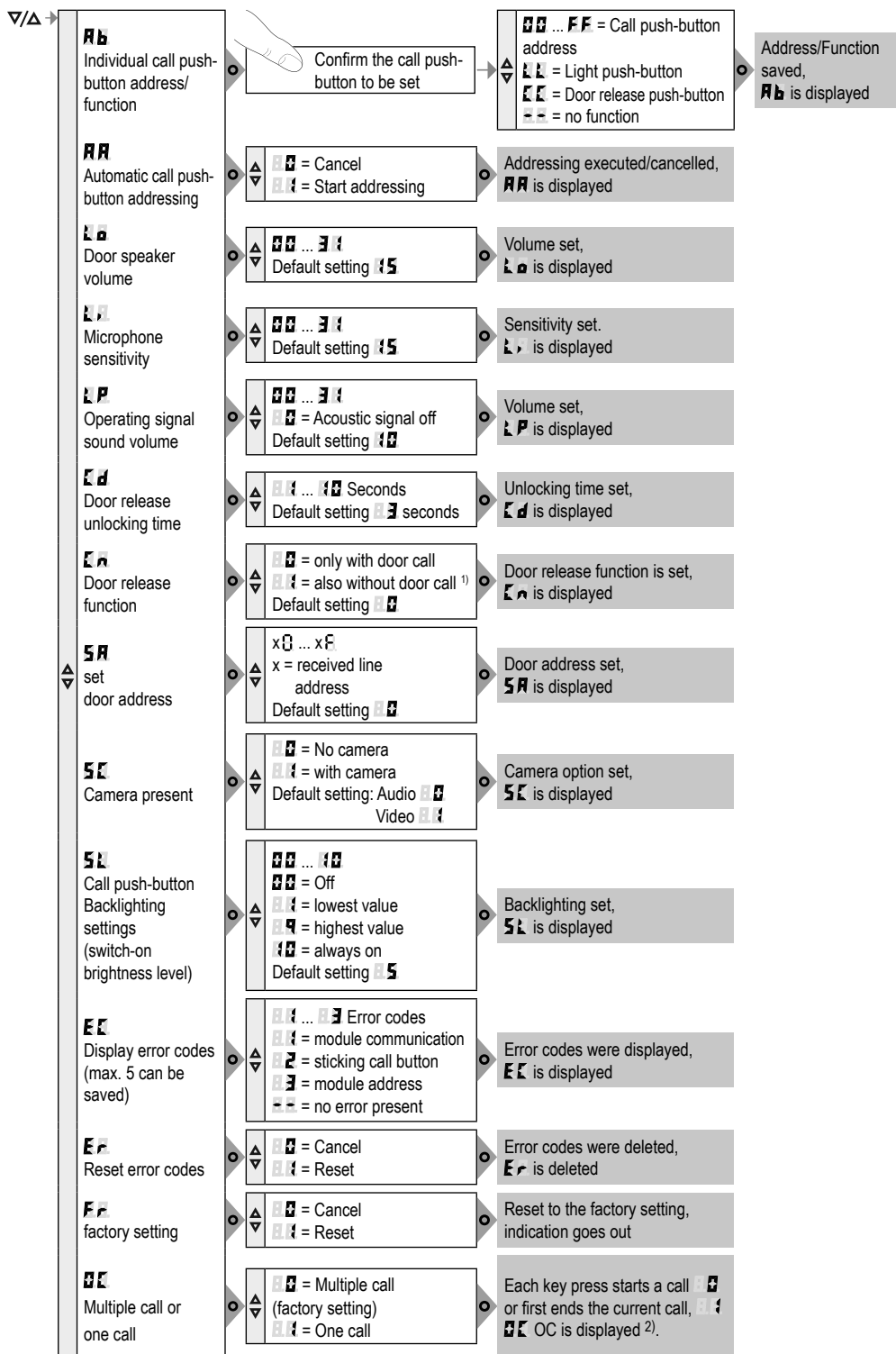

¹⁾ Door release functions without door call only possible single door systems
²⁾ OC „one call“, software version 2.0 or higher

Figure 10: Overview of system settings

- For installations using RTQ52xx, TJA510N, TJA470 or multiple door stations, multiple call **00** must be used.

Setting the values

The menu entry to be set is confirmed and flashes alternately with the value to be set.

- Press **▼ / ▲** button.

Short button-press: change the value by one step.

Long button-press: run through values. Scrolling stops when the button is released.

- Confirm set value with **○**

The device applies the setting and returns to the previous menu entry.

Automatic call push-button addressing **AA**

The call push-button and connector on the back are addressed by the automatic call push-button addressing as follows. The addressing takes place starting from the top downwards, and with a two-rowed door station, counterclockwise automatically upwards to the right (figure 11).

- Door stations are automatically pre-configured at the factory.

The menu entry **AA** is confirmed. **AA** flashes alternately with the entry **00** for cancel.

- With **▼ / ▲** select the entry **00** for automatic addressing.

- Confirm with **○**.

During the addressing, the display flickers.

Afterwards the display returns to the previous menu entry **AA**.

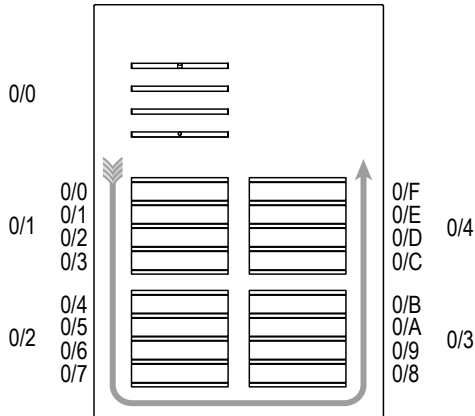

Figure 11: Module address and automatic call push-button addressing

Set individual call push-button address/function **Ab**

The menu entry **Ab** Set individual call push-button address/function is confirmed and flashes.

- Confirm the call push-button to be set.

The menu entry **Ab** flashes alternately with the current address/function.

- With **▼ / ▲** select the required address **00** ... **FF** or function **LL** for light push-button, **EE** for door release push-button or **--** for no function.

- Confirm set address/function with **○**.

The device applies the setting and returns to the previous menu entry. **Ab**.

Display saved error codes **EE**

Audio insert and call push-button module errors that occur during operation are stored in the error memory of the audio insert for diagnosis.

- Select menu entry **EE** with button **▼ / ▲** and confirm with **○**

If no error code exists **00** is displayed for 2 seconds and afterwards **EE**.

If error codes are saved **EE** flashes followed by the module address and the error code.

- Press button **▼ / ▲**, to call up further error codes if necessary.

- Press button **○** to return to menu entry **EE**.

Error code	Error cause	Counter actions
EE	Communication error between audio insert and call push-button module. Once the error has occurred 3 times, the system is reset automatically and the error code is generated.	If the error persists, the call push-button module must be replaced and addressed.
E2	sticking call button	Check call push-button module, and if there is a defect, replace and address.
E3	Writing of the call push-button address in the call push-button module fails.	If the error persists, the call push-button module must be replaced and addressed.

Table 2: Error codes and counter actions

- The memory should only be deleted once 5 error codes have been stored, so that new error codes can be saved.

- Identical error codes are only saved once.

Multiple call/one call

Multiple call, value **00** (factory setting): Each key press on the outdoor station starts a call. These calls can be answered one after the other.

One call, value **01**: Pressing a button on the outdoor station starts a call. Each additional key press ends the previous call and connects the new call. Only one call can be present in the system at any time.

Inserting door station

The system settings are complete.

- Remove opening tool from housing.
- Insert door station and press down until it clicks audibly into place simultaneously at the top and bottom if possible (Figure 12).

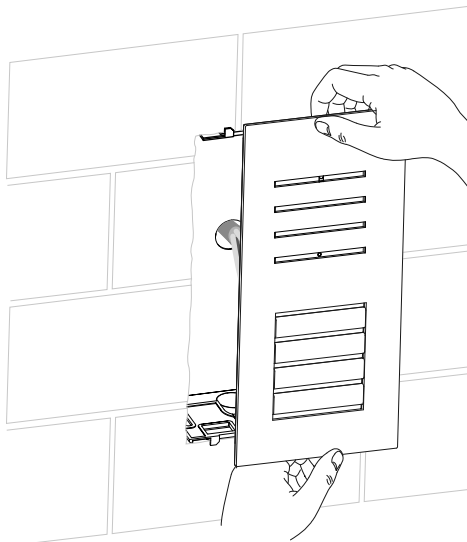

Figure 12: Insert door station

Dismantle call push-button module cover

During cleaning or replacement, the call push-button module cover can be dismantled from the front.

- Lever up the interlocking cover strips (6) at the top and bottom using the screwdriver and remove (Figure 13).

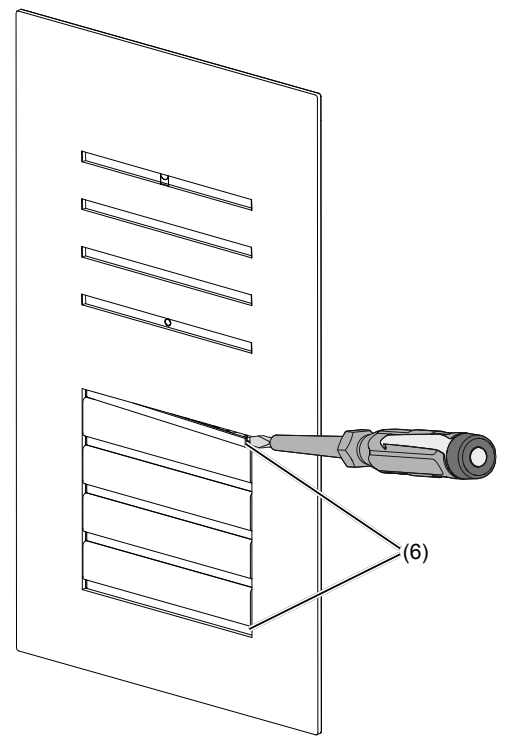

Figure 13: Removing the cover strips

- Press up the call push-button module upper part in the bottom lever opening with the screwdriver and guide it forwards (14).

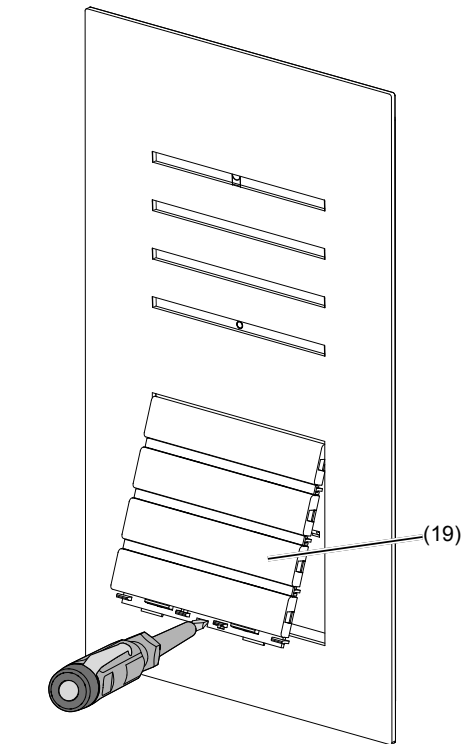

Figure 14: Dismantling the call push-button module cover

(19) Call push-button module cover

- Defective covers can only be replaced by covers with the same number of push-buttons.

- Remove the module to be replaced and install the new module in reverse order.

Open door station

- Position the opening tool (15) at the bottom in the middle and press up (Figure 15).

- With two-series door stations, use the opening tool in the middle under each series of call push-buttons.

The door station will spring out of the bottom interlocking mechanism forwards and can be opened.

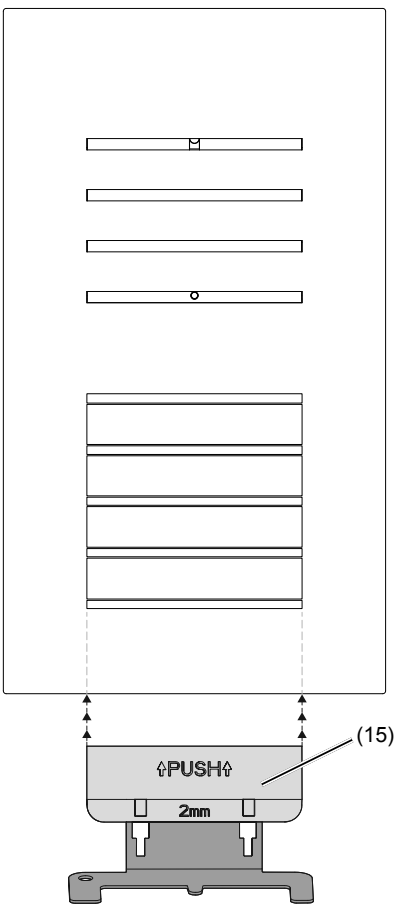

Figure 15: Disassembling the door station

Exchange module/insert

Door station is dismantled.

- Pull off connection terminal block (12) on the audio insert.
- Remove the connection cables' connectors of the module to be exchanged.
- Loosen screws (20) of the module mounting at the back (21) using a screwdriver and remove the module mounting (Figure 16).

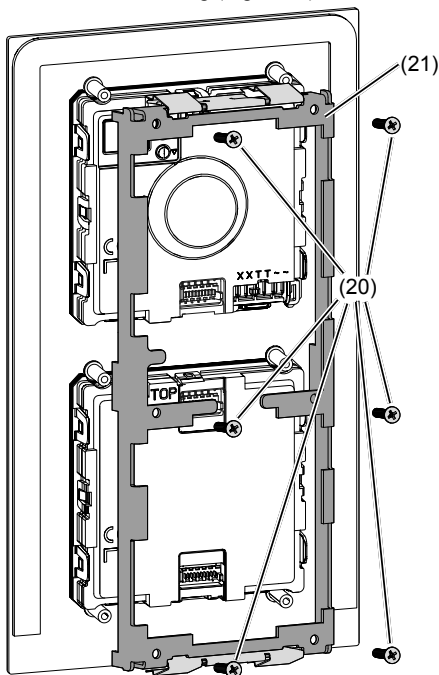

Figure 16: Dismantling module mounting

(20) Screws

(21) Module mounting

- Unlatch retaining brackets (22) of each module by carefully lifting up with a screwdriver (Figure 17).
- To remove the call push-button module, unlatch the side retaining brackets (22) of the module mounting by carefully lifting up with a screwdriver (Figure 17).

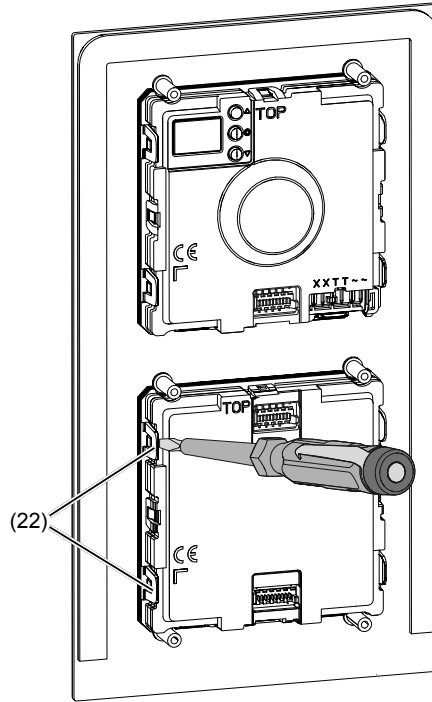

Figure 17: Unlatching module

(22) Retaining brackets module mounting

After unlatching the module detaches itself from the anchoring (22).

- Remove the module to be replaced and install the new module in reverse order.
- Automatic or manual addressing of the module is required to operate the door station.

Appendix

Technical data

Operating voltage	22 ... 24 V=
Current consumption audio insert Stand-by	5 mA
Current consumption audio insert Operation	110 mA
Current name plate lighting per call push-button module	45 mA

Menu setting	Backlighting On	Backlighting Off
0	Permanent Off	
1	≈ 750 lx	≈ 1600 lx
2	.	.
3	.	.
4	.	.
5	.	.
6	.	.
7	.	.
8	.	.
9	≈ 60 lx	≈ 110 lx
10	Permanent On	

Table 3: Switch-on brightness level name plate-lighting

Door release contact T/T potential-free max. 24 V/1 A

Door release unlocking time 1 ... 10 s

Degree of protection IP 44

Degree of protection IK07

Relative humidity 0 ... 65% (no condensation)

Operating temperature -20°C ... +55°C

Storage/transport temperature -30°C ... +80°C

Connecting terminals for conductor diameter 0.5 ... 0.8 mm

Dimensions:

Call push-button button small 75.8 x 14.5 mm

Name plate small 72.1 x 12 mm

Call push-button button medium 75.8 x 32.6 mm

Name plate medium 72.1 x 30.1 mm

Call push-button button large 75.8 x 75.8 mm

Name plate large 72.1 x 66.3 mm

Width of name plate insert max. 0.5 mm

Surface compensation with flush-mounted installation 17 mm

Dimensions door station front (W x H x D):

with 0.5 or 1 module 133.5 x 242 x 2 mm

with 0.5 and 1 module 133.5 x 295.8 x 2 mm

with 2 modules 135 x 332 x 2 mm

with 0.5 and 2 modules 133.5 x 385.8 x 2 mm

with 3 modules 133.5 x 422 x 2 mm

with 2 x 2 modules 225.5 x 332 x 2 mm

with 3 and 2 modules or with 2 x 3 modules 225.5 x 422 x 2 mm

Accessories (extract)

Flush-mounted housing for door station:

with 0.5 or 1 module	REW111Y
with 0.5 and 1 module	REW112Y
with 2 modules	REW113Y
with 0.5 and 2 modules	REW114Y
with 3 modules	REW115Y
with 2 x 2 modules	REW126Y
with 3 and 2 modules or with 2 x 3 modules	REW127Y

Surface-mounted housing for door station:

with 0.5 module or 1 module	REW211Y
with 0.5 module and 1 module	REW212Y
with 2 modules	REW213Y
with 0.5 and 2 modules	REW214Y
with 3 modules	REW215Y
with 2 x 2 modules	REW226Y
with 3 and 2 modules or with 2 x 3 modules	REW227Y

Warranty

We reserve the right to realise technical and formal changes to the product in the interest of technical progress.

Our products are under guarantee within the scope of the statutory provisions.

In case of service issues, please contact your systems' engineer.