

hw+

Air circuit breakers

HW1

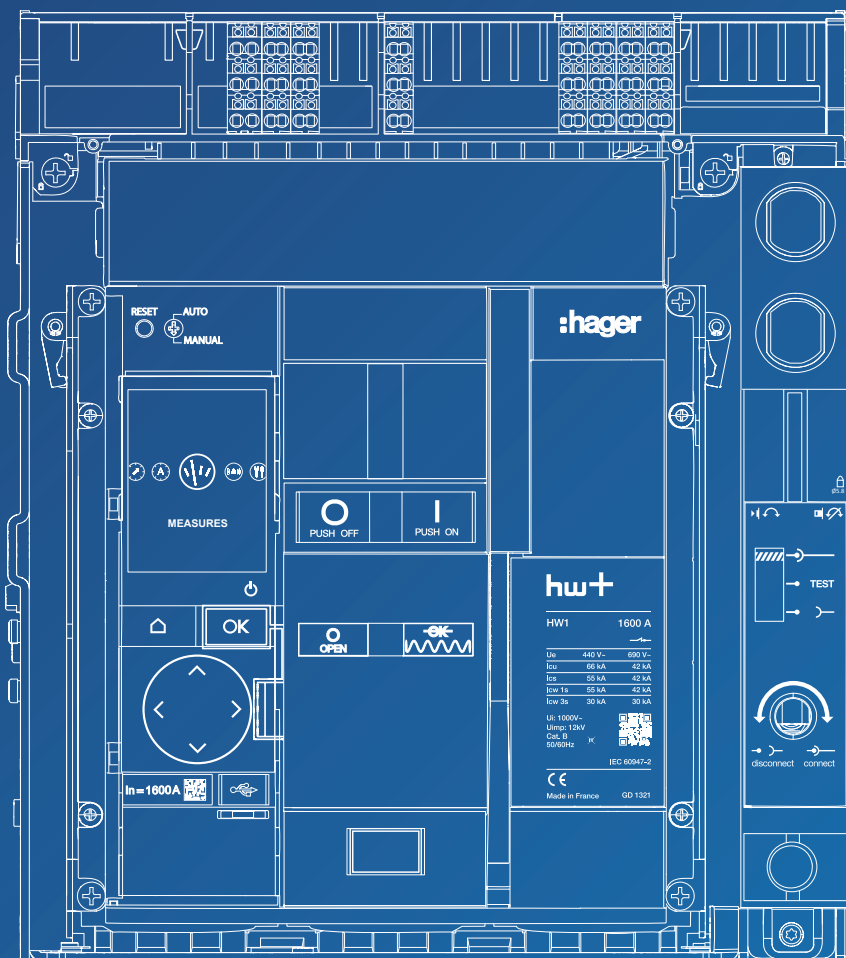

Contents

Page

01 About this manual	3
1.1 Safety instructions	3
1.2 Using this manual	5

02 Circuit breaker operation	6
2.1 Description	6
2.2 Circuit breaker closure	9
2.3 Circuit breaker opening	11
2.4 Locking the opening and closing push buttons	12
2.5 Locking the circuit breaker using padlocks	14
2.6 Locking the circuit breaker using keylocks	17
2.7 Locking the chassis using padlocks	21
2.8 Locking the chassis using keylocks	24
2.9 RI open door racking lock	28
2.10 Mechanical interlock	30

03 Positions of the drawout circuit breaker in the chassis	31
---	-----------

04 Positions of the drawout circuit breaker in the chassis	32
4.1 Changing from connected position to test position	32
4.2 Changing from test position to disconnected position	35
4.3 Changing from disconnected position to test position	37
4.4 Changing from test position to connected position	39

05 Extracting the drawout circuit breaker	41
--	-----------

06 Inserting the drawout circuit breaker	43
---	-----------

07 Closing the circuit breaker after a trip operation	45
--	-----------

Warnings and instructions

This documentation contains safety advice which must be respected for your own safety and to prevent property damage.

Safety advice relating to your own safety is identified by a safety warning symbol in the documentation. Safety advice relating to damage to property is identified by "ATTENTION". The safety warning symbols and the wording below are classified according to the risk level.



DANGER indicates an imminent dangerous situation which, if not avoided, will result in death or serious injuries.



WARNING indicates a potentially dangerous situation which, if not avoided, may result in serious injuries or even death.



CAUTION indicates a potentially dangerous situation which, if not avoided, may result in minor or moderate injuries.

ATTENTION

ATTENTION indicates a warning message relating to equipment damage.
ATTENTION also indicates important instructions for use and particularly relevant information regarding the product, which must be respected to ensure effective and safe use.

Qualified personnel

The product or the system described in this documentation must be installed, operated and maintained by qualified personnel only. Hager Electro accepts no responsibility regarding the consequences of this equipment being used by unqualified personnel.

Qualified personnel are those people who have the necessary skills and knowledge for building, operating and installing electrical equipment, and who have received training enabling them to identify and avoid the risks incurred.

Appropriate use of Hager products

Hager products are designed to be used only for the applications described in the catalogues and in the technical documentation relating to them. If products and components from other manufacturers are used, they must be recommended or approved by Hager.

Appropriate use of Hager products during transport, storage, installation, assembly, commissioning, operation and maintenance is required to guarantee problem-free operation in complete safety.

The permissible ambient conditions must be respected. The information contained in the technical documentation must be respected.

Publication liability

The contents of this documentation have been reviewed in order to ensure that the information is correct at the time of publication.

Hager cannot, however, guarantee the accuracy of all the information contained in this documentation. Hager assumes no responsibility for printing errors and any damage they may cause.

Hager reserves the right to make the necessary corrections and modifications to subsequent versions.

Purpose of the document.

This manual is designed to provide users, electricians, panel builders and maintenance personnel with the technical information required to use the HW1 circuit breakers with electronic trip units.

Field of application

This document is applicable to HW1 circuit breakers in the hw+ range.

Revisions

Version	Date
6LE007331Ad	December 2023

Documents to consult

Document	Reference
Installation manual for HW1 air circuit breakers	6LE007893A
HW1 user maintenance guide	6LE007897A
User manual for sentinel hw+ electronic trip units	6LE007969A
User manual for sentinel Energy hw+ electronic trip units	6LE008147A
sentinel Energy Modbus communication guide	6LE007964A
HTD210H panel display user guide	6LE002999A

You can download these publications and other technical information from our website: www.hager.com

Contact

Address	Hager Electro SAS 132 Boulevard d'Europe 67215 Obernai France
Phone	+ 33 (0)3 88 49 50 50
Website	www.hager.com

The HW1 circuit breaker has the following elements on the front:

- ① Charging handle
- ② Closing push button
- ③ Closing spring status indicator
- ④ Contact opening and closing indicator
- ⑤ Opening push button
- ⑥ RESET re-arm button

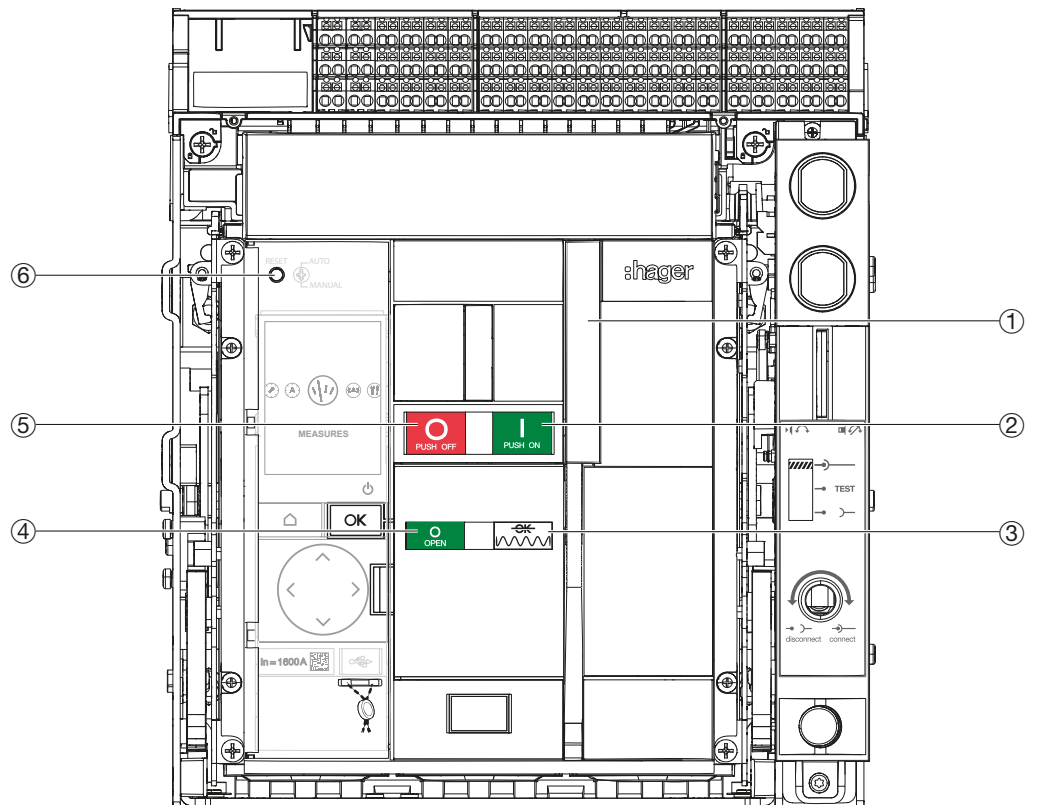

Status indicators

The combination of the two indicators shows the status of the circuit breaker.

Opening and closing indicator	Closing spring status indicator	Circuit breaker status
		Circuit breaker open. Closing spring discharged.
		Circuit breaker open. Closing spring charged but not ready to close because: <ul style="list-style-type: none"> • Following tripping, the circuit breaker has not been reset (see Chapter 07 Closing the circuit breaker after tripping). • The circuit breaker is mechanically locked in the open position using a lock or padlock.
		Circuit breaker open. Closing spring charged. The circuit breaker is ready to be closed.
		Circuit breaker closed. Closing spring discharged.
		Circuit breaker closed. Closing spring charged.

RESET re-arm button

The RESET re-arm button is used to reset the circuit breaker after tripping (see Chapter 07 Closing the circuit breaker after tripping).

The operation of the RESET re-arm button depends on the Auto or Manual mode set using the adjustment dial on the right.

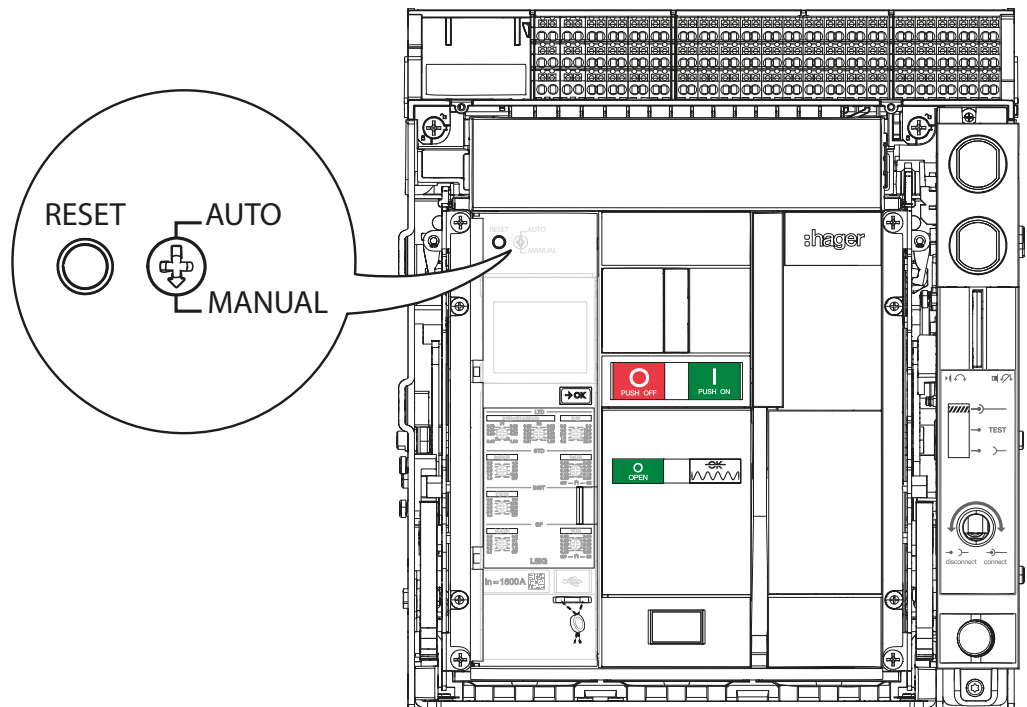

- **Auto mode**, in which it is not necessary to press the RESET re-arm button before closing the circuit breaker again after tripping.

This mode is usually used if the circuit breaker is remotely monitored, as it can be closed without requiring a person to perform the action on-site.

- **Manual mode**, in which the RESET re-arm button must be pressed in before closing the circuit breaker again after tripping.

ATTENTION	
Risk of property damage	
<p>To switch from Auto to Manual mode, always turn the dial anti-clockwise.</p> <div style="display: flex; justify-content: space-around; align-items: center;"> <div style="text-align: center;"> <p>OK</p> </div> <div style="text-align: center;"> <p>OK</p> </div> </div>	<p>To switch from Manual to Auto mode, always turn the dial clockwise.</p> <div style="display: flex; justify-content: space-around; align-items: center;"> <div style="text-align: center;"> <p>OK</p> </div> <div style="text-align: center;"> <p>OK</p> </div> </div>

Closing spring

The closing spring is used to mechanically close the circuit breaker. It must be charged first, and there are two procedures for this:

- Manual charging

Charge the spring using the charging handle until the status of the indicator changes.

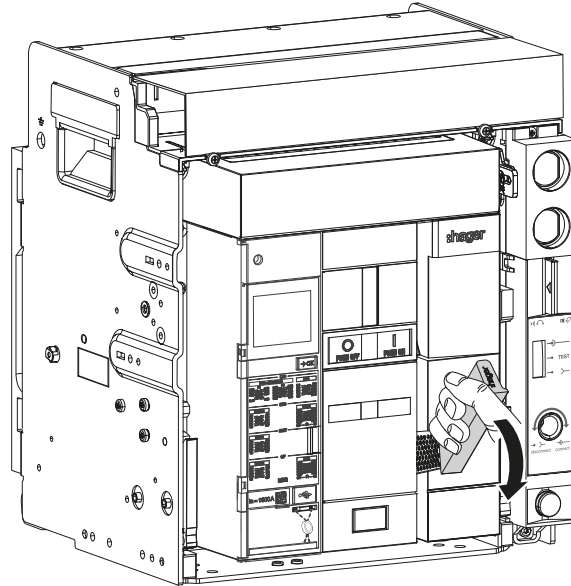

- Automatic charging

If an MO charging motor is installed and powered, the closing spring charges automatically each time the circuit breaker closes.

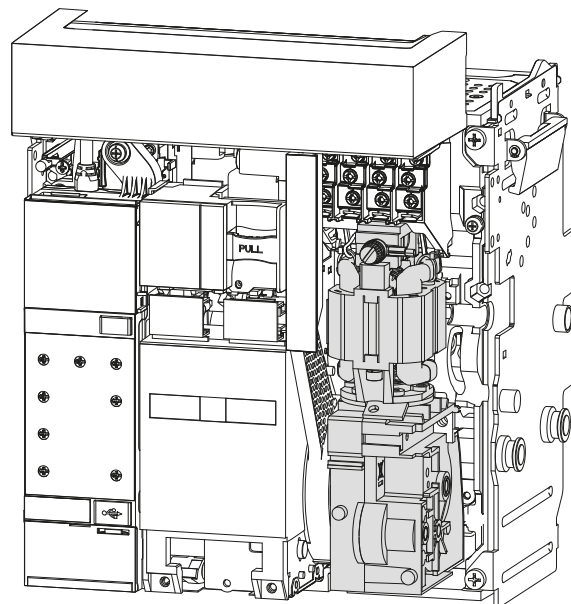



Risk of electric shock, explosion or electric arc.

Inspect the electrical installation and remove the tripping cause before closing the circuit breaker again.



Never close a circuit breaker locally or remotely without first making sure that the installation complies with the safety standards.

To close the circuit breaker:

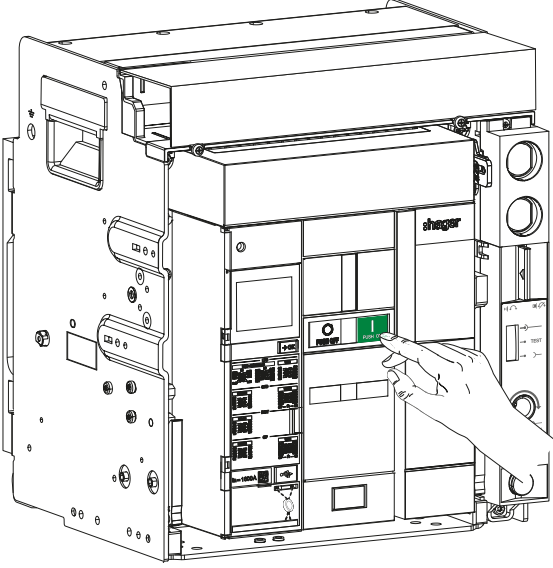
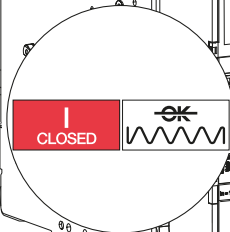
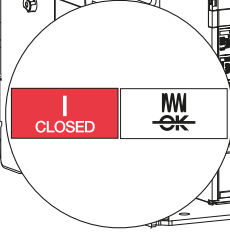
	Action	Illustration
1	Check that the circuit breaker is open, the closing spring is discharged or charged if a charging motor is installed.	<p>The illustration shows a circuit breaker in its open position. Two circular callouts highlight the status indicators. The top callout shows a green bar with a white circle and the word 'OPEN', and a white bar with a black 'OK' symbol and a wavy line. The bottom callout shows a green bar with a white circle and the word 'OPEN', and a yellow bar with a black 'OK' symbol and a wavy line.</p>
2	If necessary, charge the closing spring using the charging handle until the following indicators appear.	<p>The illustration shows a hand operating the charging handle of the circuit breaker. A circular callout highlights the status indicators, which are now a green bar with a white circle and the word 'OPEN', and a yellow bar with a black 'OK' symbol and a wavy line.</p>

	Action	Illustration
3	<p>Close the circuit breaker by pressing the closing push button</p> 	
4	<p>Check that the indicators change status.</p>	
5	<p>If a charging motor is installed and powered, the closing spring charges automatically.</p>	

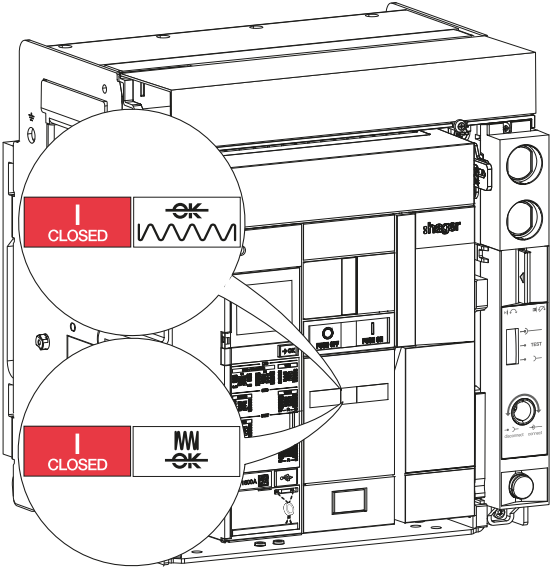
To open the circuit breaker:

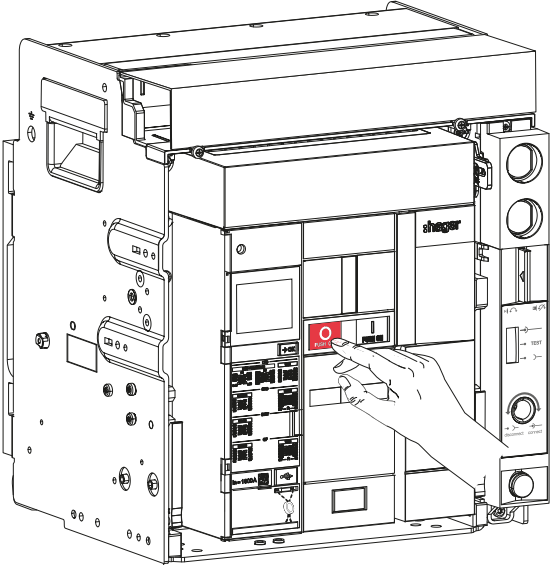
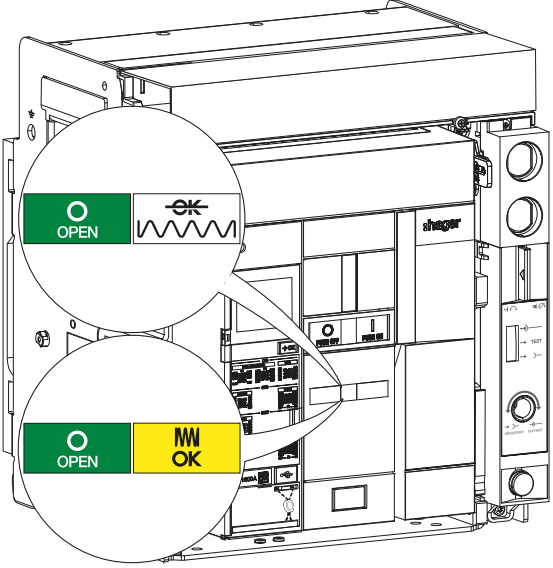
	Action	Illustration
1	<p>Check that the following indicators appear on the circuit breaker.</p>	 <p>The illustration shows a circuit breaker with two callout circles. The top circle shows a red bar with a vertical line and the word 'CLOSED' next to a green bar with a wavy line and 'OK'. The bottom circle shows a red bar with a vertical line and 'CLOSED' next to a yellow bar with a wavy line and 'OK'.</p>
2	<p>Open the circuit breaker by pressing the opening push button</p> 	 <p>The illustration shows a hand pressing a red button with a white circle on the front panel of the circuit breaker.</p>
3	<p>Check that the indicators update:</p> <ul style="list-style-type: none"> - indicator OPEN, - closing spring discharged indicator (case of manual charging), - or closing spring charged indicator (automatic charging with motor). 	 <p>The illustration shows a circuit breaker with two callout circles. The top circle shows a green bar with a circle and the word 'OPEN' next to a green bar with a wavy line and 'OK'. The bottom circle shows a green bar with a circle and 'OPEN' next to a yellow bar with a wavy line and 'OK'.</p>

The closing PUSH ON and opening PUSH OFF push buttons can be locked against any operation using the PBC push button covers.

It prevents any unintended or unauthorised operation.

The transparent PBC push button covers have an additional function.

They can be disengaged and turned so that the opening push button PUSH OFF remains permanently and mechanically engaged. This locking function is also guaranteed if the circuit breaker is activated remotely by a CC closing coil. Even if the CC closing coil is driven, the principal contacts remain open.



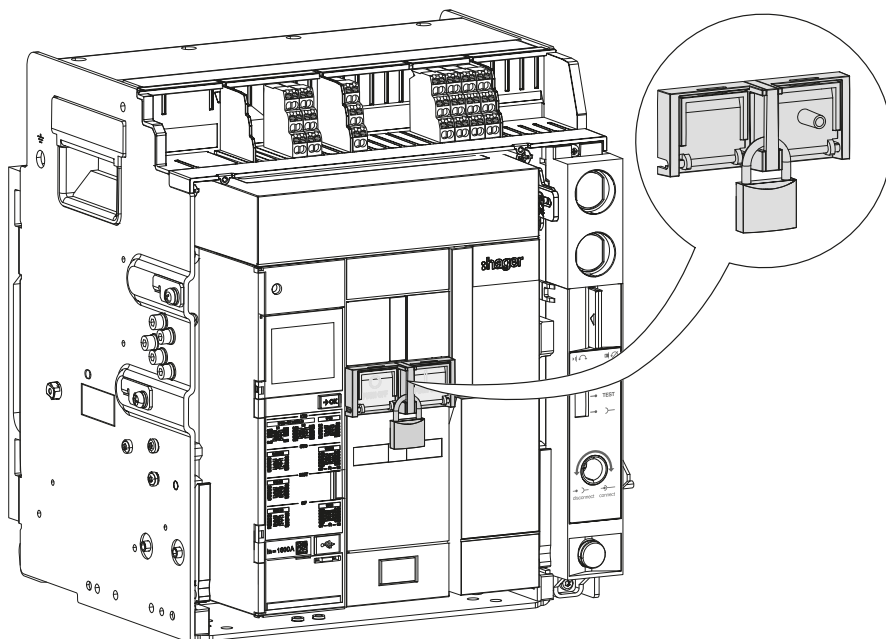

This prevents any unintentional or unauthorised operations.

The push buttons can be locked independently or jointly and up to 3 Ø5-Ø8 mm padlocks can be fitted.



To activate the locking device:

Action	Illustration
<p>1 Close the cover of the push button you wish to lock.</p>	

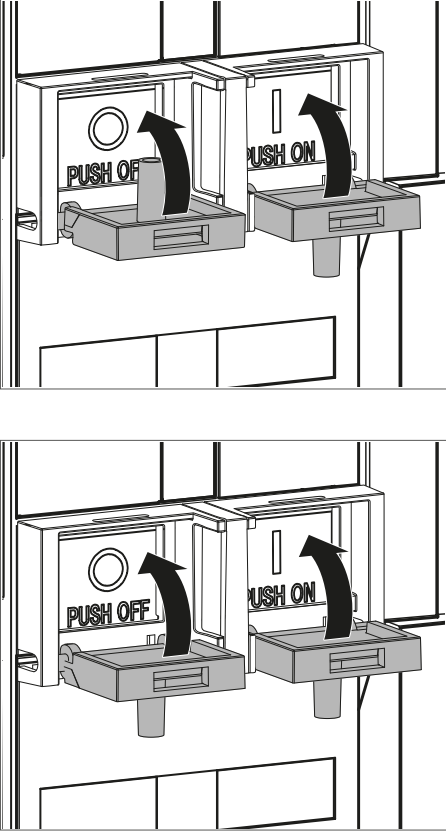
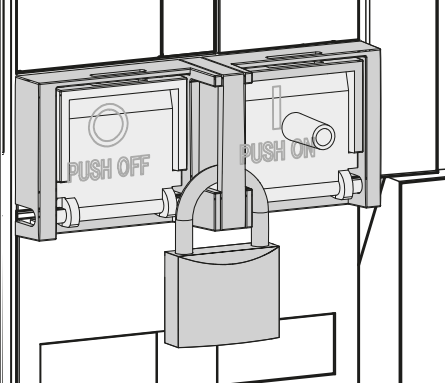
Action	Illustration
<p>1 Case 1 The opening push button</p>  <p>is pressed continuously and the closing push button</p>  <p>is locked.</p> <p>Case 2 The opening push button</p>  <p>and closing push button</p>  <p>are locked.</p>	
<p>2 Lock it using one or more padlocks.</p>	

ATTENTION

It is not possible to hold down the closing push button with this accessory.





ATTENTION



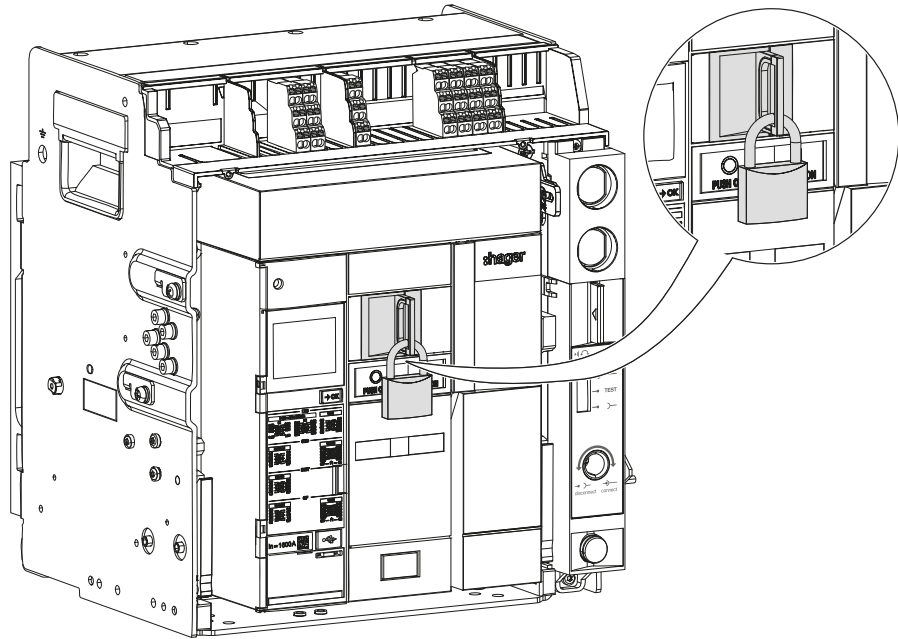

Refer to manual 6LE007490A to install this locking accessory.

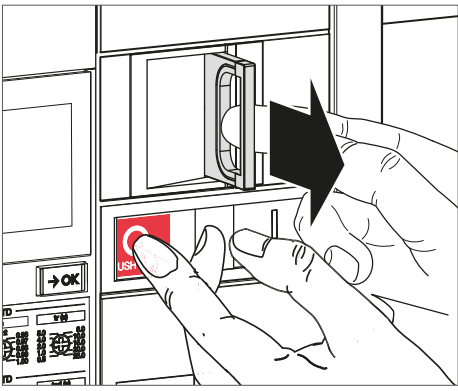
This locking device prevents the circuit breaker from closing using padlocks.
Up to three Ø5–Ø8 mm padlocks can be installed.

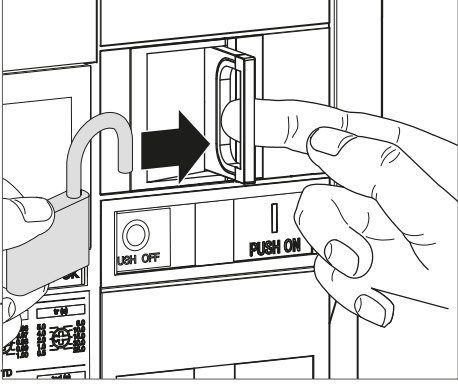

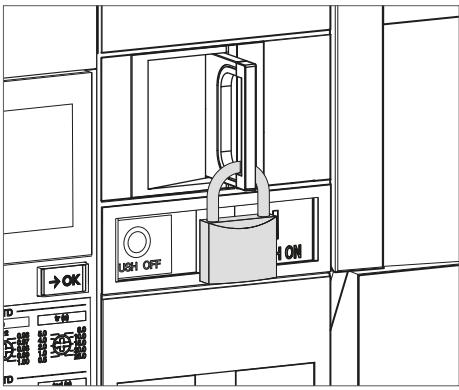
To activate or deactivate the locking device:

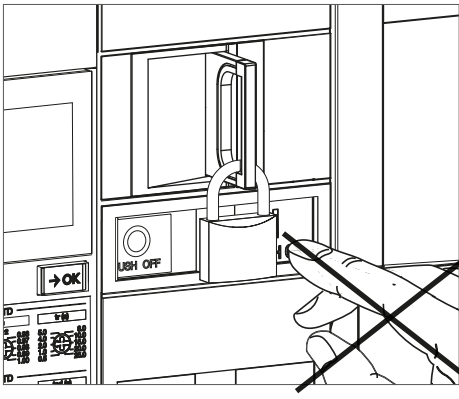
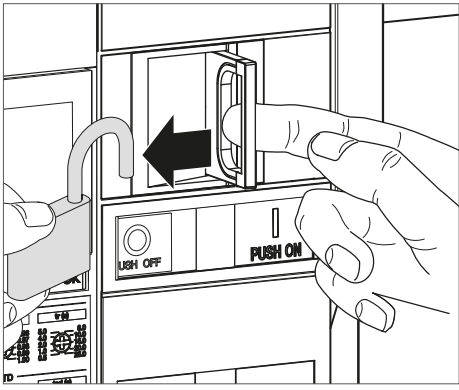
Action	Illustration
<p>1 Press the opening push button</p>  <p>and, while holding it down, pull the tab of the locking device.</p>	
<p>2 Release the opening push button</p>  <p>while holding the tab. The PUSH OFF push button remains pressed in. Position...</p>	

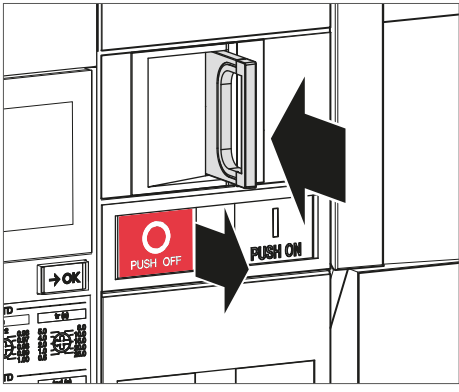
Action	Illustration
<p>2 (continued) ... Then close the padlock.</p>	
<p>3 Check that it is no longer possible to close the circuit breaker by pressing the closing push button</p> 	
<p>4 To unlock the device, remove the padlock.</p>	
<p>5 The tab and the opening push button return to their initial position.</p> 	

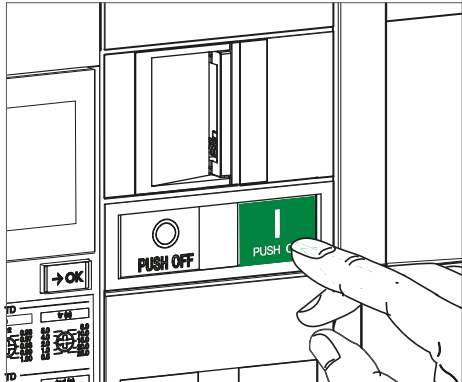
Action	Illustration
<p>6 Check that it is now possible to close the circuit breaker by pressing the closing push button</p> 	

ATTENTION

Refer to manual 6LE007488A to install this locking accessory.

This locking device prevents the circuit breaker from closing using a key lock.
Several types of locks can be installed.

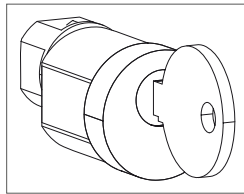

Ronis type lock

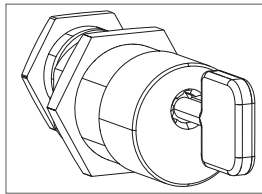



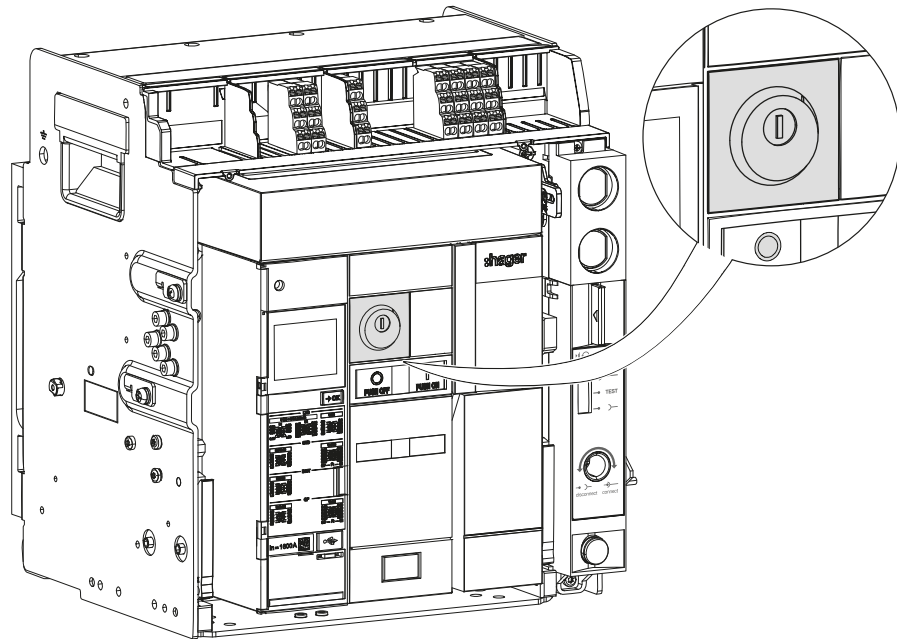



Profalux type key lock (not offered by us)

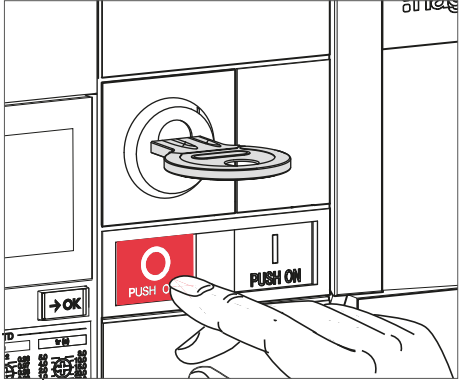

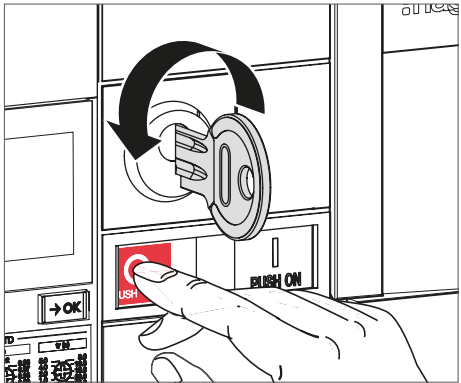
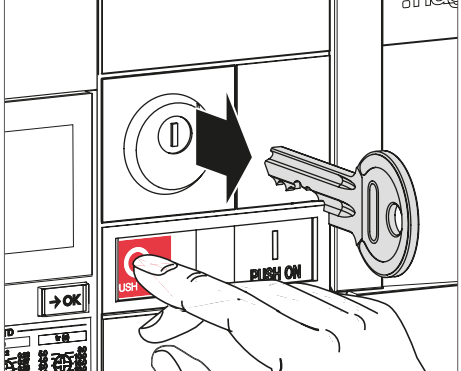

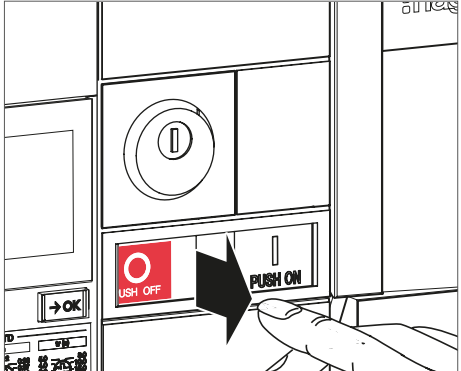
To activate or deactivate the locking device:

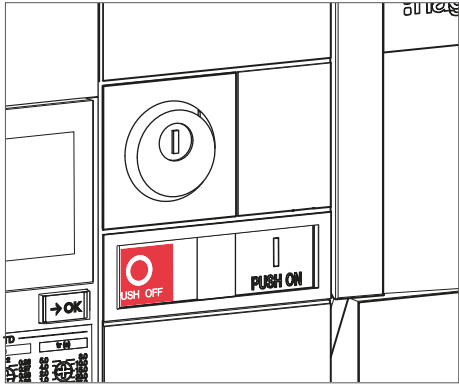
Action	Illustration
<p>1 Check that the key is in the horizontal position.</p>	

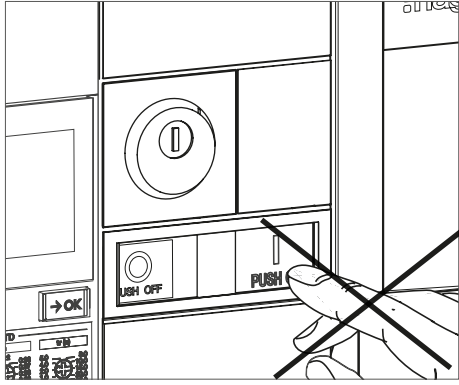
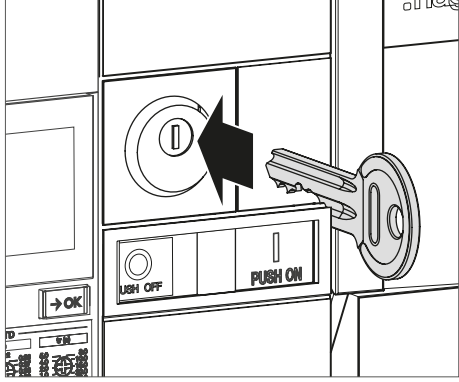
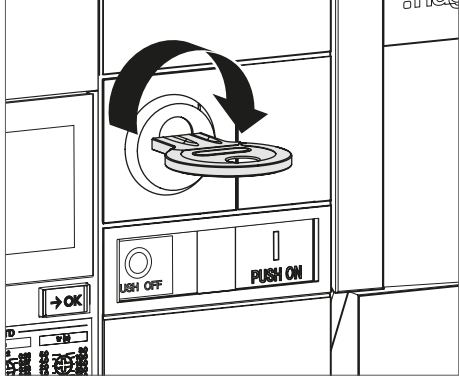
Action	Illustration
<p>2 Press the opening push button</p> 	
<p>3 While holding down the opening push button, put the key back into the vertical position by turning it counter-clockwise.</p> 	
<p>4 Remove the key.</p>	
<p>5 Then release the opening push button</p> 	

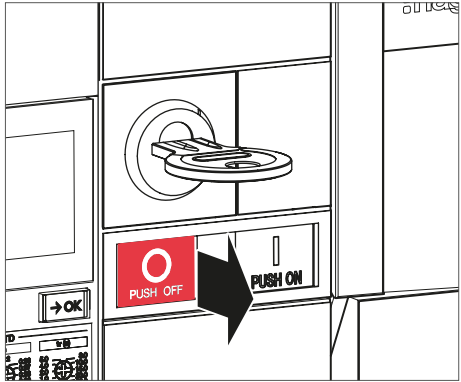
Action	Illustration
<p>5 (continued) It remains pressed in.</p>	
<p>6 Check that it is no longer possible to close the circuit breaker by pressing the closing push button</p> 	
<p>7 To unlock the device, insert the key into the lock.</p>	
<p>8 Turn the key clockwise.</p>	

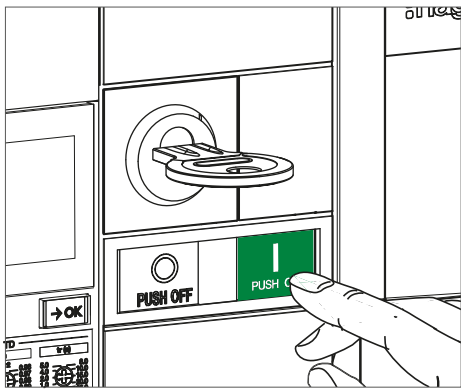
Action	Illustration
<p>8 <i>(continued)</i> The push button returns to its initial position.</p>	
<p>9 Check that it is now possible to close the circuit breaker by pressing the closing push button</p> 	

ATTENTION

The key cannot be removed in horizontal position.
 To remove it, follow steps 1 to 4.

ATTENTION

Refer to manual 6LE007488A to install this locking accessory.

This locking device locks the circuit breaker in the chassis and prevents the racking handle from being inserted.

Up to three Ø5–Ø8 mm padlocks can be installed.

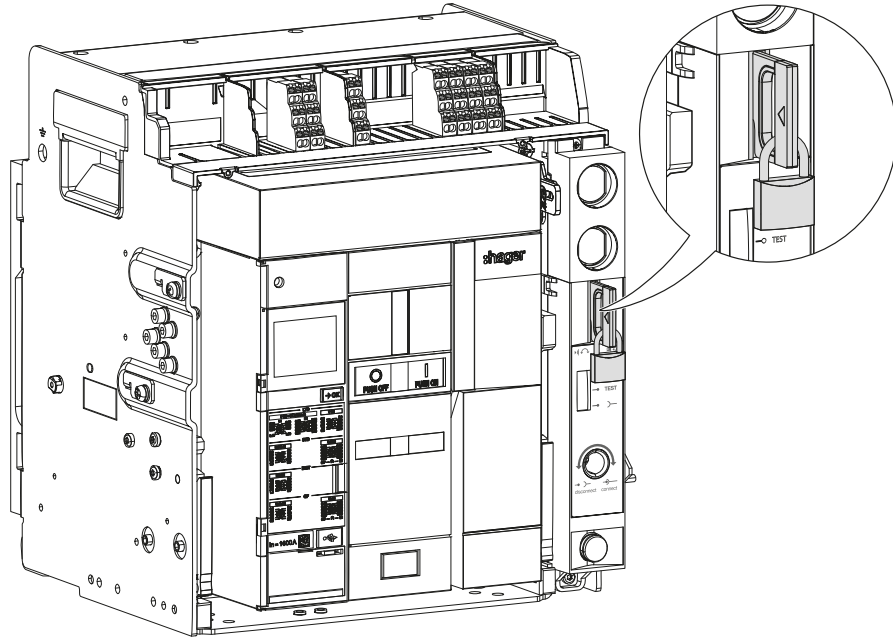

To activate or deactivate the locking device:

Action	Illustration
<p>1 Pull the padlocking and position acknowledgement tab.</p>	

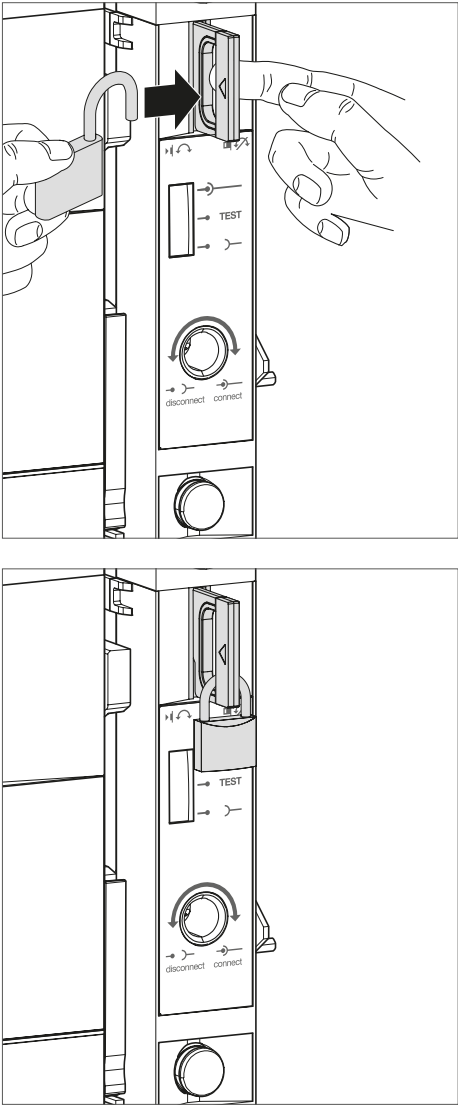
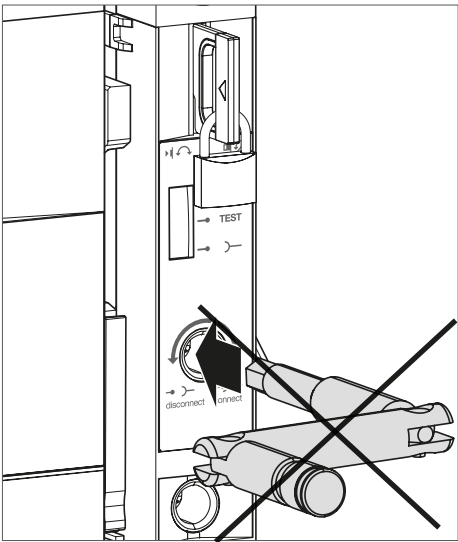
Action	Illustration
<p>2 Position...</p> <p>then close the padlock.</p>	 <p>The top illustration shows a hand inserting a padlock into the racking handle mechanism. The bottom illustration shows the padlock fully closed and secured.</p>
<p>3 Check to ensure that it is not possible to insert the racking handle into the place to insert/withdraw.</p>	 <p>The illustration shows the racking handle mechanism with a padlock in place. A hand is shown attempting to insert a racking handle, which is blocked by the padlock. A large 'X' is drawn over the handle and the padlock mechanism to indicate that this action is not possible.</p>

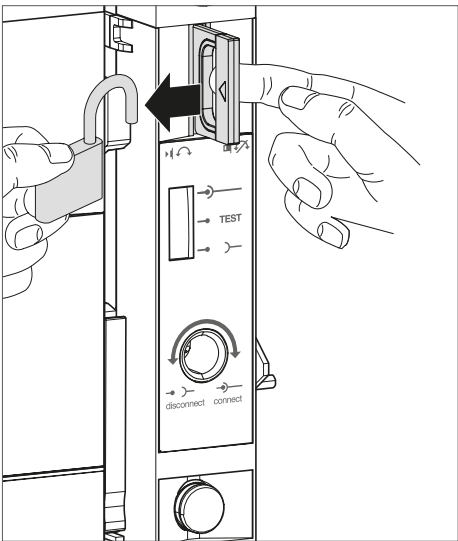
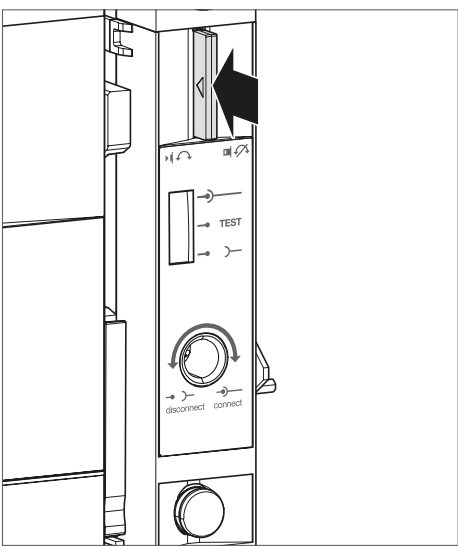
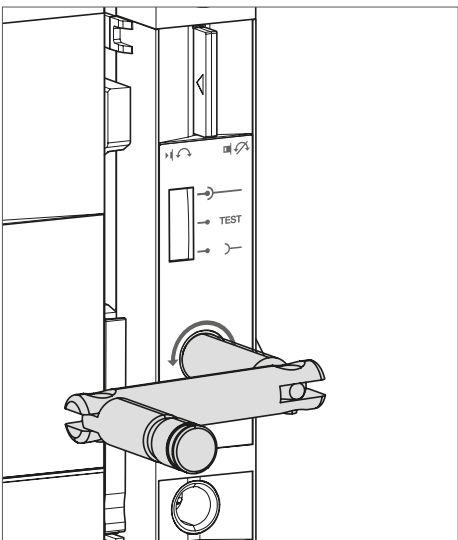
Action	Illustration
<p>4 To unlock the device, remove the padlock.</p>	
<p>5 Check that the padlocking and position acknowledgement tab returns to its initial position.</p>	
<p>6 Check that it is now possible to insert the racking handle into the place to insert/withdraw.</p>	

This locking device locks the circuit breaker in the chassis and prevents the racking handle from being inserted.

Several types of locks can be installed.

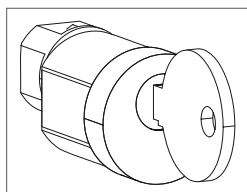

Ronis type lock

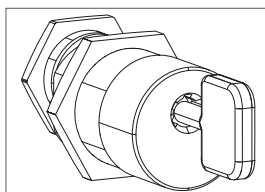

Profalux type key lock (not offered by us)

Up to 2 locks can be installed in the housing.

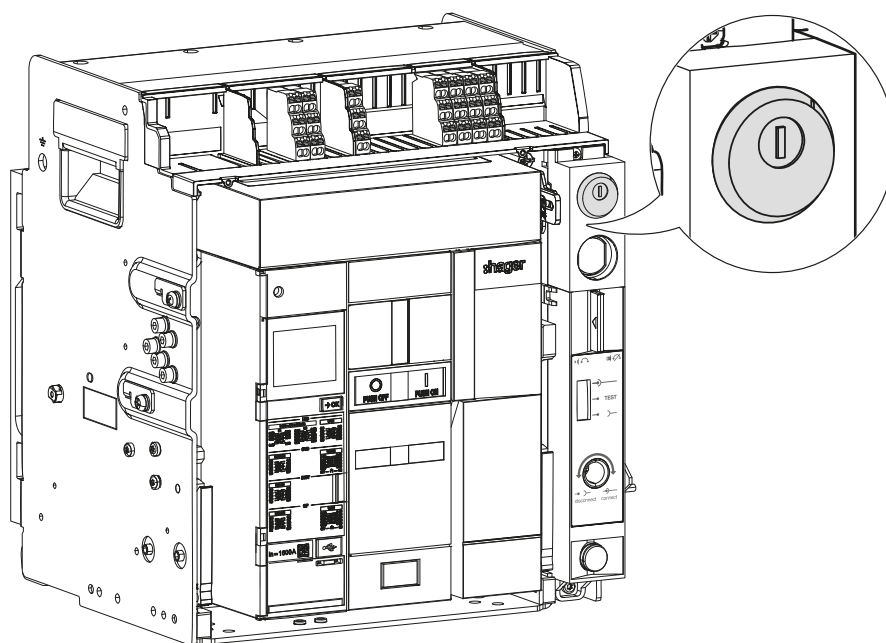
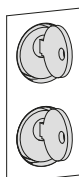

To activate or deactivate the locking device:

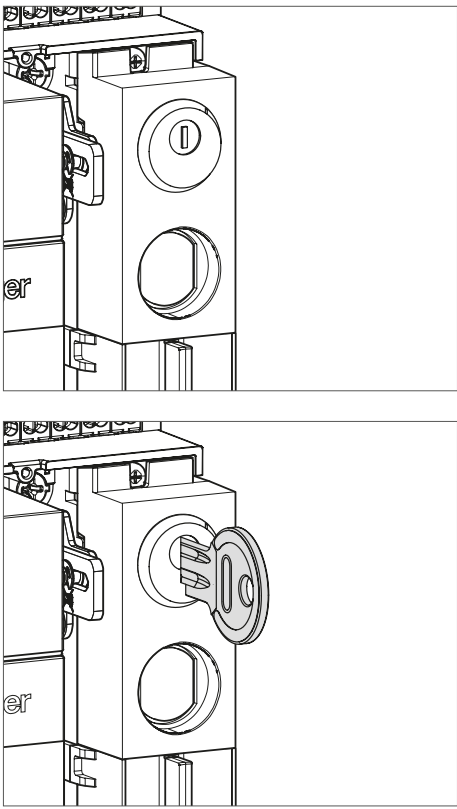
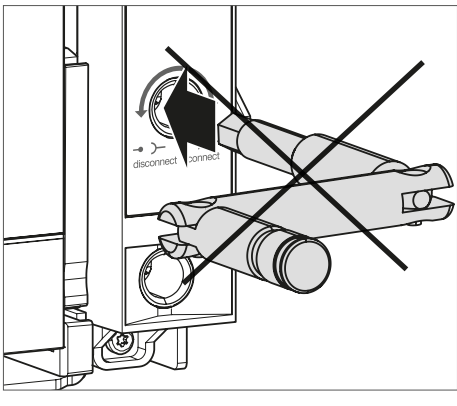
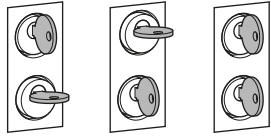
Action	Illustration
<p>1 Check that the keylock is in the vertical position... or that the key is inserted in the vertical position.</p>	
<p>2 Check to ensure that it is not possible to insert the racking handle into the place to insert/withdraw.</p>	
<p>ATTENTION</p>	
<p>If 2 locks are installed, only one key in the vertical position prevents the introduction of the racking handle into the place to insert/withdraw.</p>	

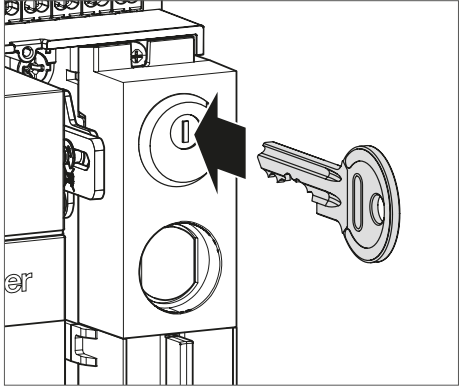
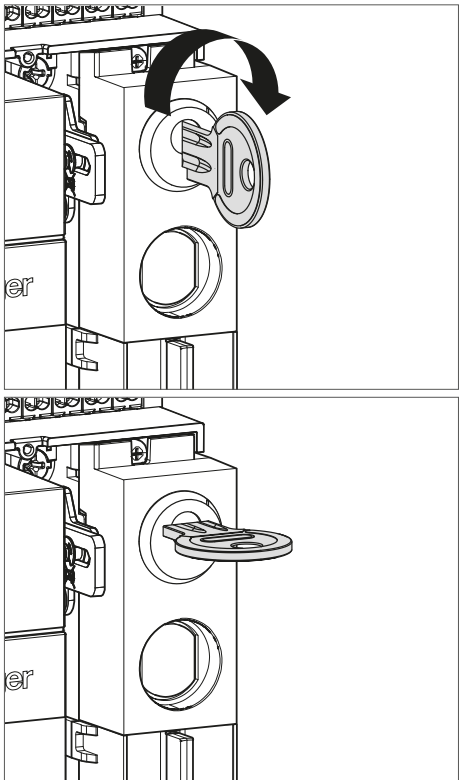
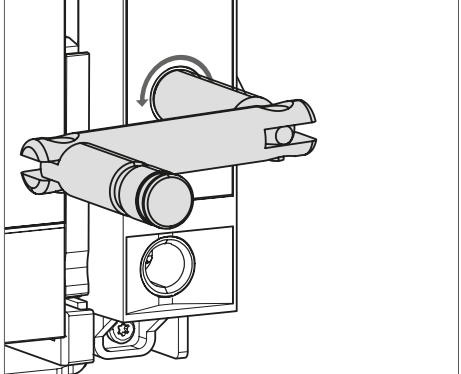
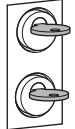
Action	Illustration
<p>3 To unlock the device, insert the key into the lock.</p>	
<p>4 Turn the locking device key clockwise.</p> <p>to put it in the horizontal position.</p>	
<p>5 Check that it is now possible to insert the racking handle into the place to insert/withdraw.</p>	
<p>ATTENTION</p>	
<p>If 2 locks are installed, both keys must be in the horizontal position to allow the introduction of the racking handle into the place to insert/withdraw.</p>	
	

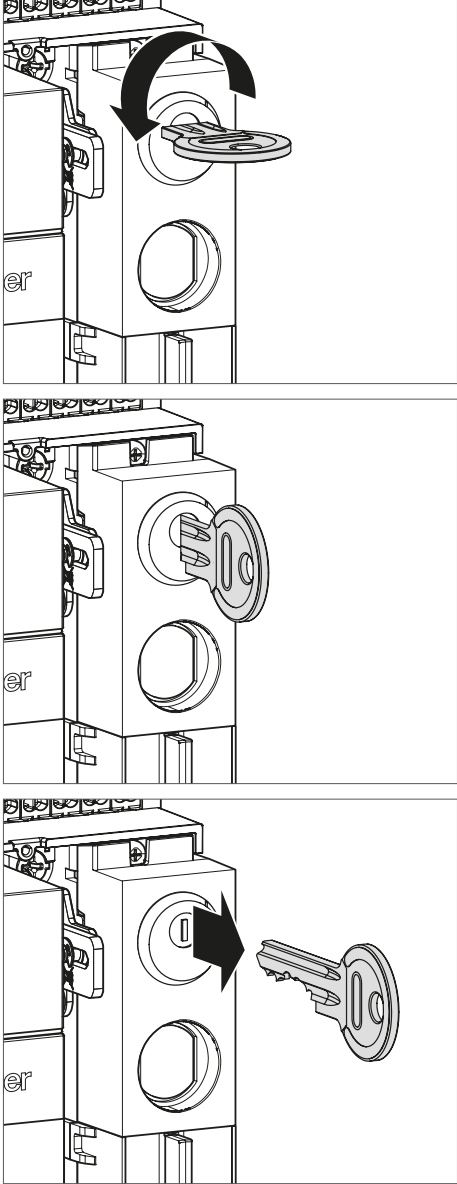
Action	Illustration
<p>6 Remove the racking handle from the place to insert/withdraw.</p> <p>The key cannot be removed in horizontal position. To remote it, turn the key anti-clockwise...</p> <p>until it is in the vertical position.</p>	

ATTENTION

For the installation of this accessory, refer to the manual 6LE007677A.

This device prevents the racking handle being inserted into the circuit breaker rack in/rack out mechanism when the door of the electrical distribution board is open.

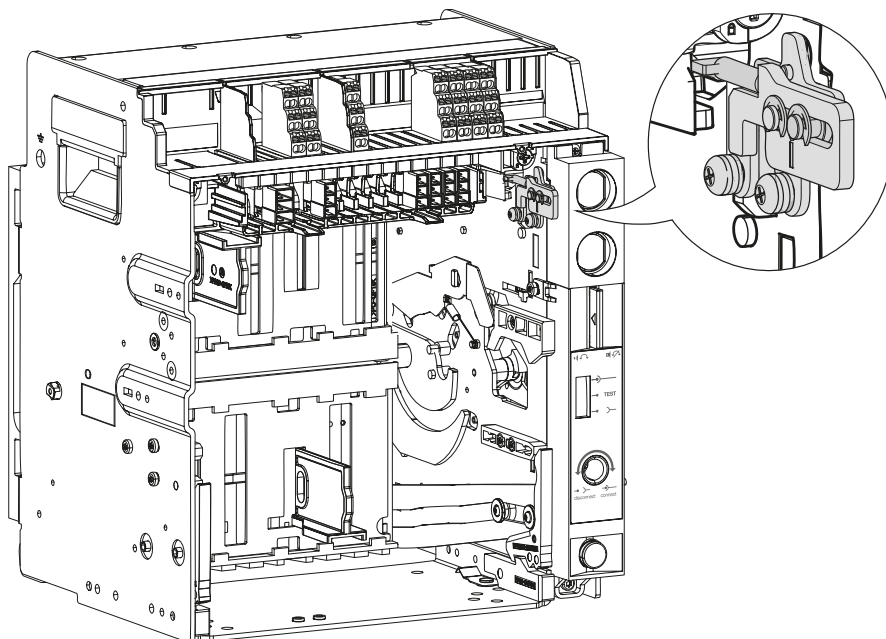

To test the locking device:

Action	Illustration
<p>1 Open the electrical distribution board door.</p>	

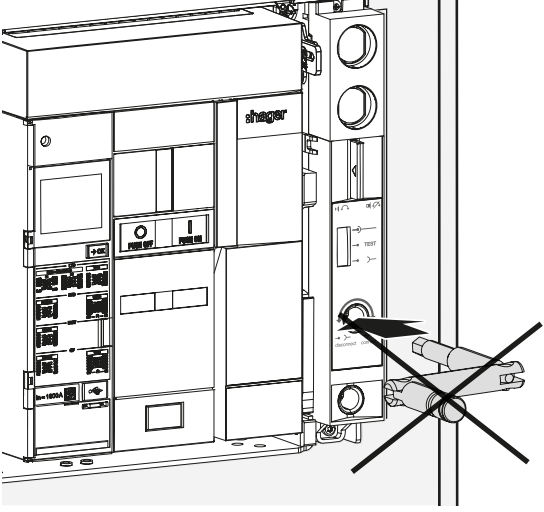
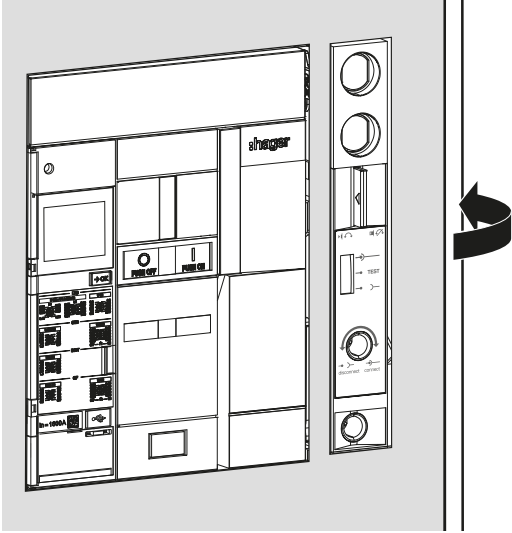
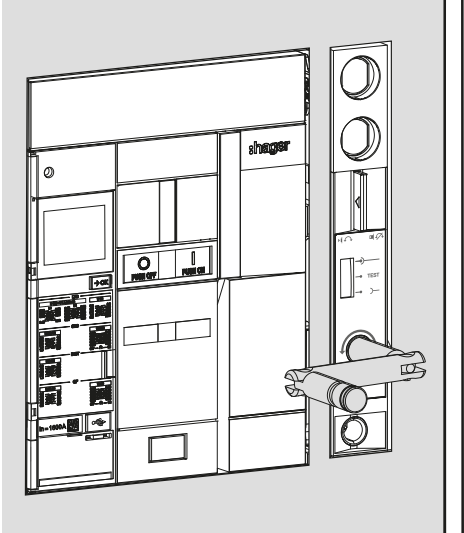
Action	Illustration
<p>2 Check to ensure that it is not possible to insert the racking handle into the place to insert/withdraw.</p>	
<p>3 Close the electrical distribution board door.</p>	
<p>4 Check that it is now possible to insert the racking handle into the place to insert/withdraw.</p>	

ATTENTION

Refer to manual 6LE007491A to install this locking accessory.

The interlocking kit is used to interlock 2 to 3 circuit breakers installed vertically or horizontally in the electrical distribution board.

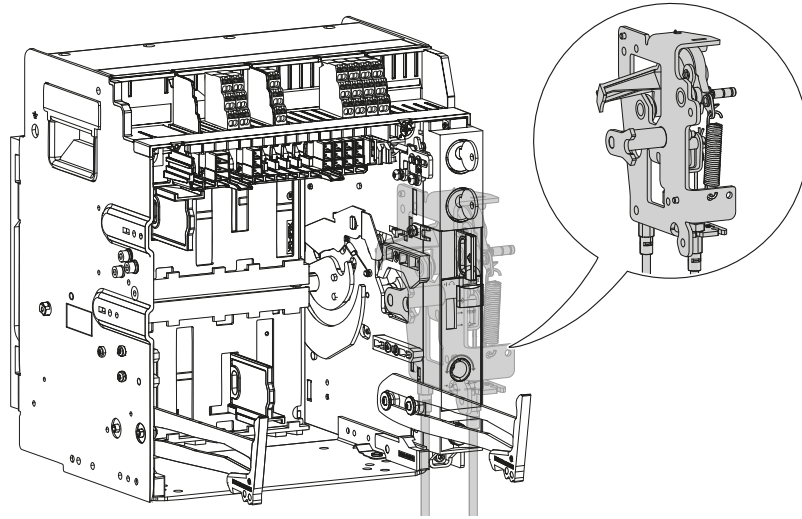

In this way it prevents interlocked circuit breakers closing at the same time according to the types of application described below:

Application	Backup								
Source	1 transformer + 1 standby generator								
Type	2 S								
Description	Prevents two circuit breakers from being closed at the same time								
Truth table	<table border="1"> <thead> <tr> <th>ACB 1</th> <th>ACB 2</th> </tr> </thead> <tbody> <tr> <td>0</td> <td>0</td> </tr> <tr> <td>1</td> <td>0</td> </tr> <tr> <td>0</td> <td>1</td> </tr> </tbody> </table>	ACB 1	ACB 2	0	0	1	0	0	1
ACB 1	ACB 2								
0	0								
1	0								
0	1								
Diagram									
Required link cables between circuit breakers	2 cables								
Locking between	2 circuit breakers								
Receiver	1 receiver								

The position of the circuit breaker in the chassis is shown by the mechanical position indicator of the moving part on the front. There are three different positions, connected, test and disconnected.

Changing from one position to another is done using a racking handle.

Before changing from one position to another, the padlocking and position acknowledgement tab must be pressed.

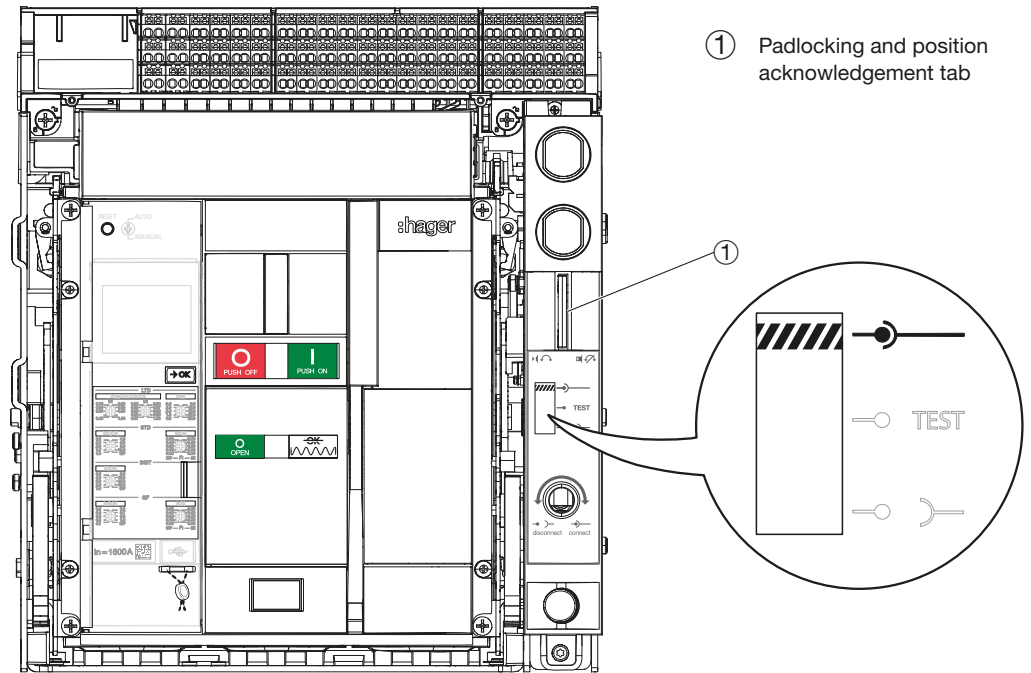

Circuit breaker position	Circuit breaker status	Mechanical position indicator of the moving part
Disconnected	The circuit breaker can be withdrawn from or inserted into the chassis.	 TEST
Test	The circuit breaker's power contacts are isolated. All of the auxiliaries remain electrically connected so that they remain functional.	TEST
Connected	The connections on the circuit breaker are connected to the jaw contacts on the chassis. The circuit breaker is ready for operation.	 TEST



WARNING

Risk of electric shock

Make sure that the device is only operated by qualified personnel in accordance with to the installation standards in force in the relevant country.

To change from connected position to test position:

Action	Illustration
<p>1 Check that the circuit breaker is in the connected position and the mechanical position indicator displays:</p>	
<p>2 Open the circuit breaker by pressing the opening push button</p> 	
<p>3 Remove the racking handle from its place.</p>	

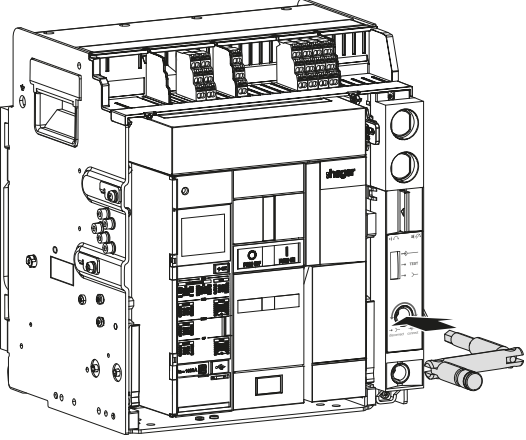
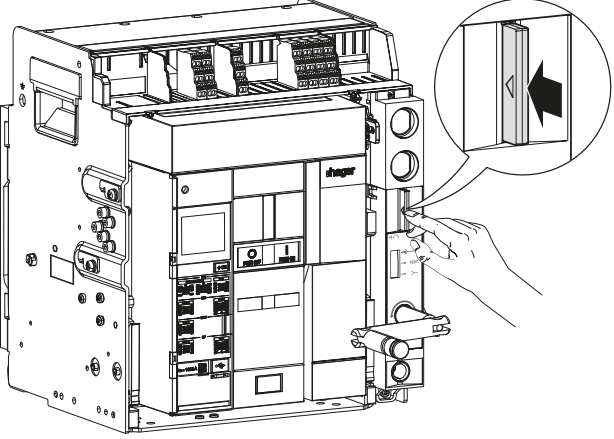
Action	Illustration
4 Insert the racking handle into the racking-in/racking-out hole.	 A technical line drawing of a Hager circuit breaker chassis. The front door is open, revealing internal components. On the right side of the chassis, there is a vertical slot. A racking handle, which is a long, thin metal rod with a handle at the end, is shown being inserted into this slot. The handle is currently partially inserted, with the handle end pointing outwards to the right.
5 Press the padlocking and position acknowledgement tab.	 A technical line drawing of the same Hager circuit breaker chassis. A hand is shown pressing a small tab located on the right side of the chassis, just below the racking handle. A circular inset provides a magnified view of this tab, showing a black arrow pointing to the left, indicating the direction in which the tab should be pressed.

Action	Illustration
<p>6 Turn the racking handle anti-clockwise...</p> <p>... until the mechanical position indicator displays:</p> <p>and the padlocking and position acknowledgement tab comes out of its housing.</p>	<p>The illustration consists of three sequential drawings of a drawout circuit breaker in a chassis. In the first drawing, an arrow points to the racking handle on the right side of the unit. In the second drawing, a callout bubble shows a mechanical position indicator with a hatched bar and the word 'TEST'. In the third drawing, a callout bubble shows a tab extending from the housing with a right-pointing arrow and the sound effect 'Clac!'.</p>

ATTENTION

Risk of property damage

If the chassis is not fitted in an electrical panel, ensure it is correctly fastened before changing position.

To change from test position to disconnected position:

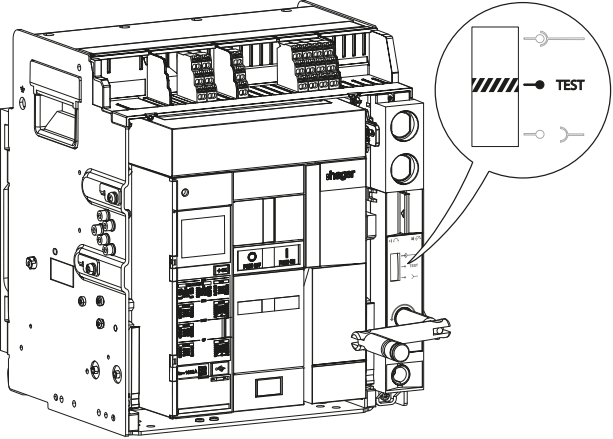
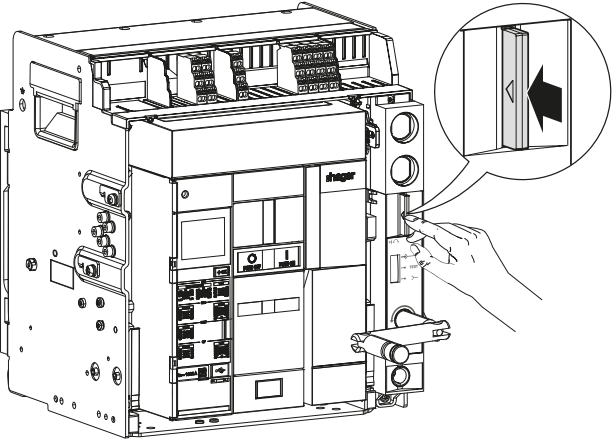
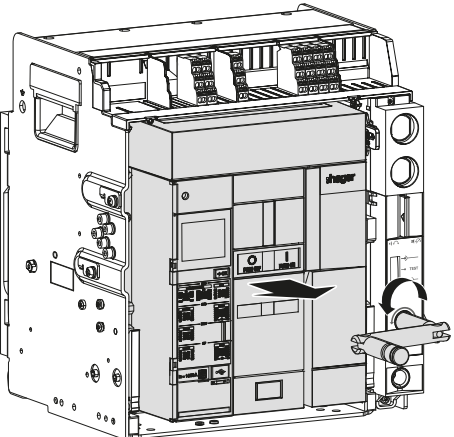
Action	Illustration
<p>1 Check that the circuit breaker is in the test position and the mechanical position indicator displays:</p>	
<p>2 Press the padlocking and position acknowledgement tab.</p>	
<p>3 Turn the racking handle anti-clockwise...</p>	

Action	Illustration
<p>3 ... until the mechanical position indicator displays:</p> <p>and the padlocking and position acknowledgement tab comes out of its housing.</p>	
<p>4 Remove the racking handle.</p>	
<p>5 Place the racking handle back in its place.</p>	



WARNING

Risk of electric shock

Make sure that the device is only operated by qualified personnel in accordance with to the installation standards in force in the relevant country.

To change from disconnected position to test position:

Action	Illustration
<p>1 Check that the circuit breaker is in the disconnected position and that the mechanical position indicator displays:</p>	
<p>2 Remove the racking handle from its place.</p>	
<p>3 Insert the racking handle into the racking-in/racking-out hole.</p>	

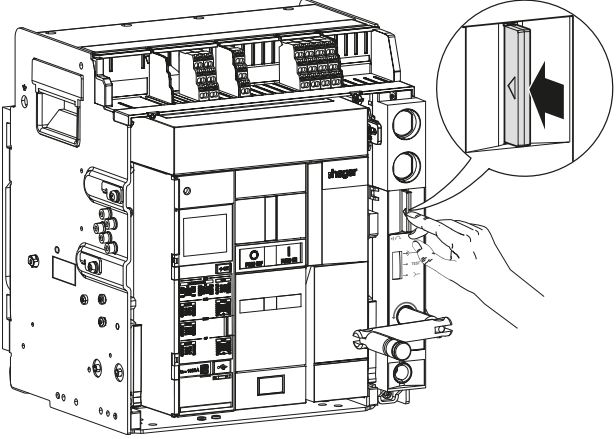
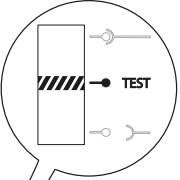
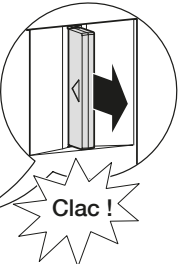
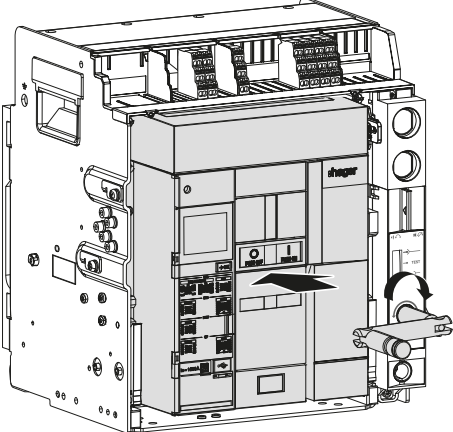
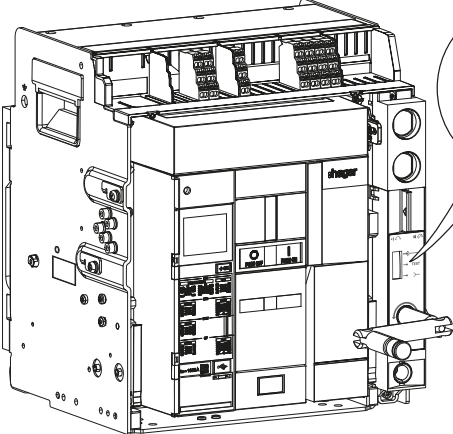
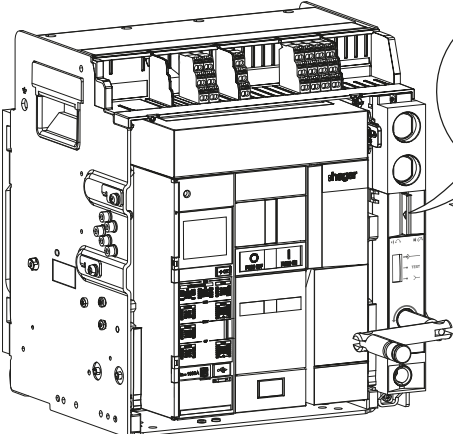
Action	Illustration
<p>4 Press the padlocking and position acknowledgement tab.</p>	
<p>5 Turn the racking handle clockwise...</p> <p>... until the mechanical position indicator displays:</p>  <p>and the padlocking and position acknowledgement tab comes out of its housing.</p> 	  

To change from test position to connected position:

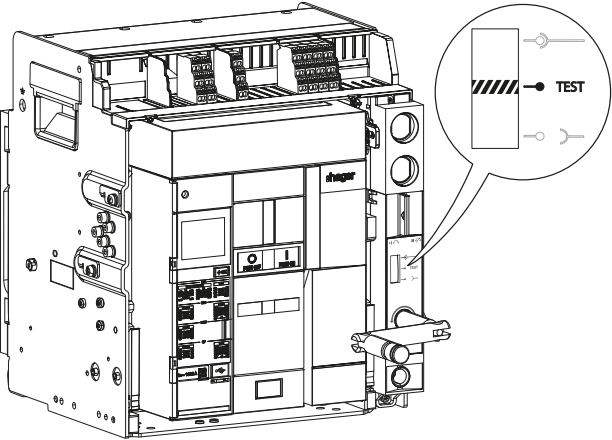
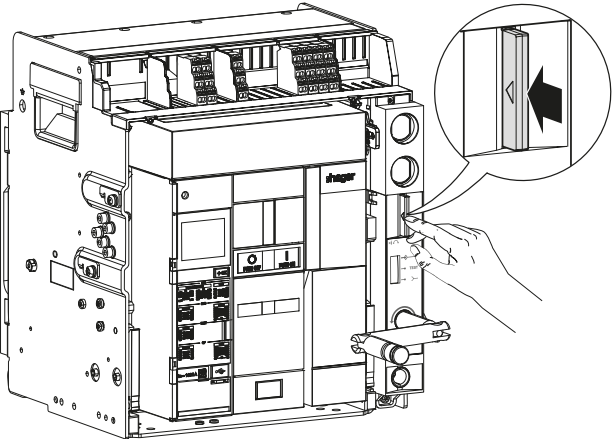
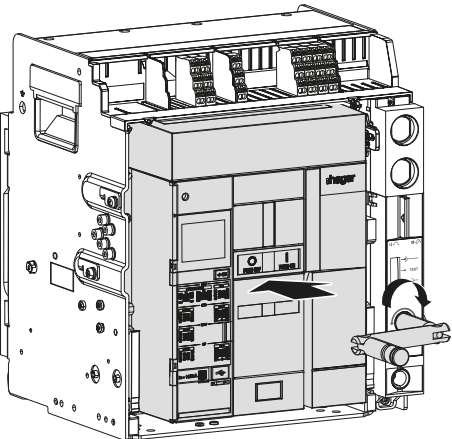
Action	Illustration
<p>1 Check that the circuit breaker is in the test position and the mechanical position indicator displays:</p>	
<p>2 Press the padlocking and position acknowledgement tab.</p>	
<p>3 Turn the racking handle clockwise...</p>	

Action	Illustration
<p>3 ... until the mechanical position indicator displays:</p> <p>and the padlocking and position acknowledgement tab comes out of its housing.</p>	
<p>4 Remove the racking handle.</p>	
<p>5 Place the racking handle back in its place.</p>	



Risk of the circuit breaker falling out
Risk of injury by crushing.

Before handling the circuit breaker, ensure the chassis is fastened within the electrical distribution board. Ensure the device is only handled by qualified personnel equipped with lifting equipment and suitable safety equipment.

Action	Illustration
<p>1 Check that the circuit breaker is in the disconnected position (cf. Chapters 4.1 Changing from the connected position to the test position and 4.2 Changing from the test position to the disconnected position).</p>	
<p>2 The circuit breaker remains in the chassis in the disconnected position. Pull the guide rails as far as possible while holding the upper part of the circuit breaker.</p>	
<p>3 Slide the circuit breaker from the chassis on its guide rails.</p>	

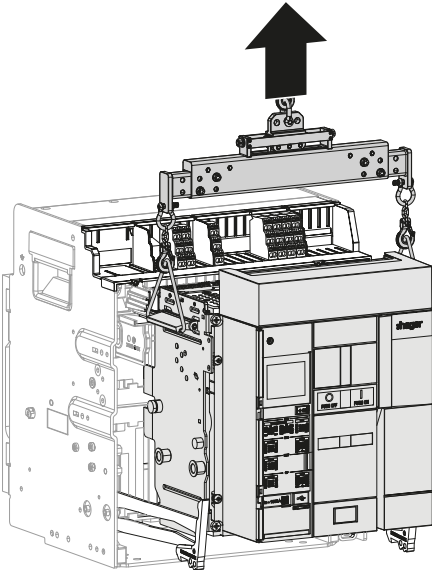
Action	Illustration
4 Remove the circuit breaker from the guide rails using an appropriate lifting device.	



Risk of the circuit breaker falling out
Risk of injury by crushing.

Before handling the circuit breaker, ensure the chassis is fastened within the electrical distribution board. Ensure the device is only handled by qualified personnel equipped with lifting equipment and suitable safety equipment.

Action	Illustration
<p>1 Check that the chassis is in the disconnected position.</p>	
<p>2 Pull the guide rails as far as possible.</p>	
<p>3 Using suitable lifting equipment, position the circuit breaker on the guide rails.</p>	

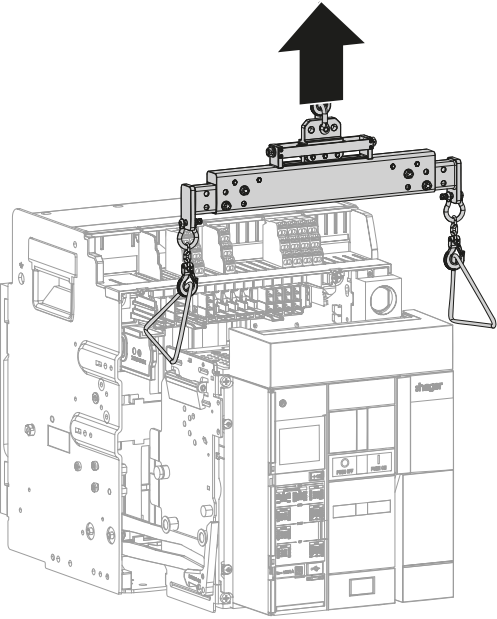
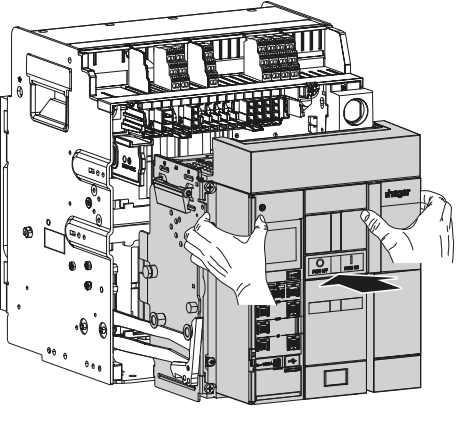
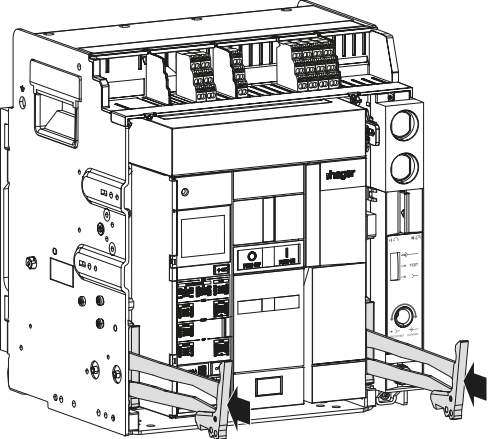
Action	Illustration
<p>4 Remove the lifting equipment.</p>	
<p>5 Push the circuit breaker to the back of the chassis without pushing on the guide rails.</p>	
<p>6 Push the guide rails to the back of the chassis.</p>	

After tripping, the circuit breaker is open, the closing spring discharged if a charging motor is not installed. The circuit breaker is open, the spring charged if a charging motor is installed. The electronic trip unit display flashes.

To understand the cause of the tripping, refer to the 6LE007969A user manual for hw+ sentinel electronic trip units and the 6LE008147A user manual for hw+ sentinel Energy electronic trip units.

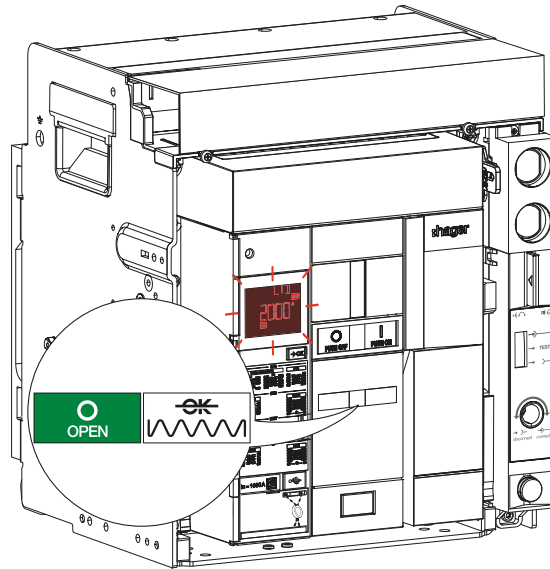

Risk of electric shock, explosion or electric arc.

Inspect the electrical installation and remove the tripping cause before closing the circuit breaker again.

Never close a circuit breaker locally or remotely without first making sure that the installation complies with the safety standards.

To close the circuit breaker:

	Action	Illustration
1	<p>Charge the spring using the charging handle until the status of the indicator changes.</p> <p>If a spring charging motor is installed, move on to step 2.</p>	<p>A technical line drawing of a Hager circuit breaker cabinet, similar to the one above. A hand is shown operating the charging handle on the right side of the cabinet. The digital display still shows '2000'.</p>

	Action	Illustration
2	<p>If the circuit breaker reset is configured to MANUAL, move on to step 3.</p> <p>If the circuit breaker reset type is set to AUTO, go directly to step 5.</p>	
3	<p>Check that the indicators display:</p> <p>The closing spring is charged, but the circuit breaker is not ready to be closed.</p>	

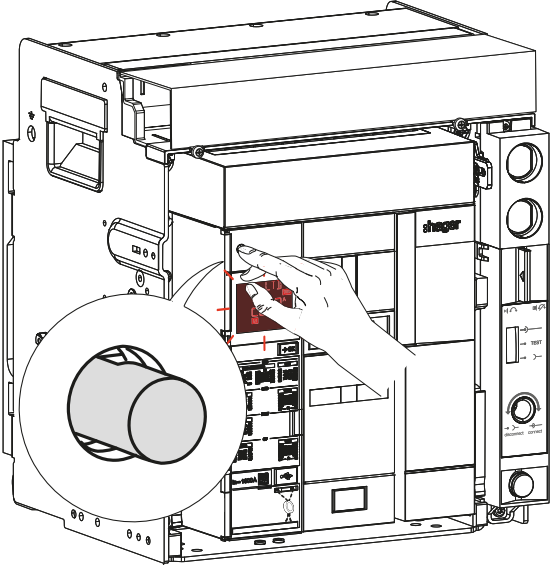
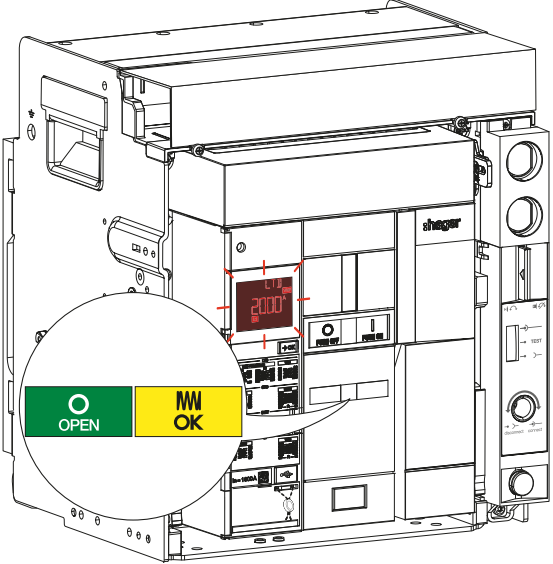
	Action	Illustration
4	Press the circuit breaker RESET re-arm button.	 <p>The illustration shows a hand pressing a red button labeled 'RESET' on the front panel of a circuit breaker. A circular callout provides a magnified view of the button and the internal mechanism.</p>
5	Check that the closing spring is charged. The circuit breaker is now ready to be closed.	 <p>The illustration shows the circuit breaker with a digital display showing '2000'. A circular callout shows a status indicator with a green 'O' and 'OPEN' on the left, and a yellow 'MM' and 'OK' on the right.</p>

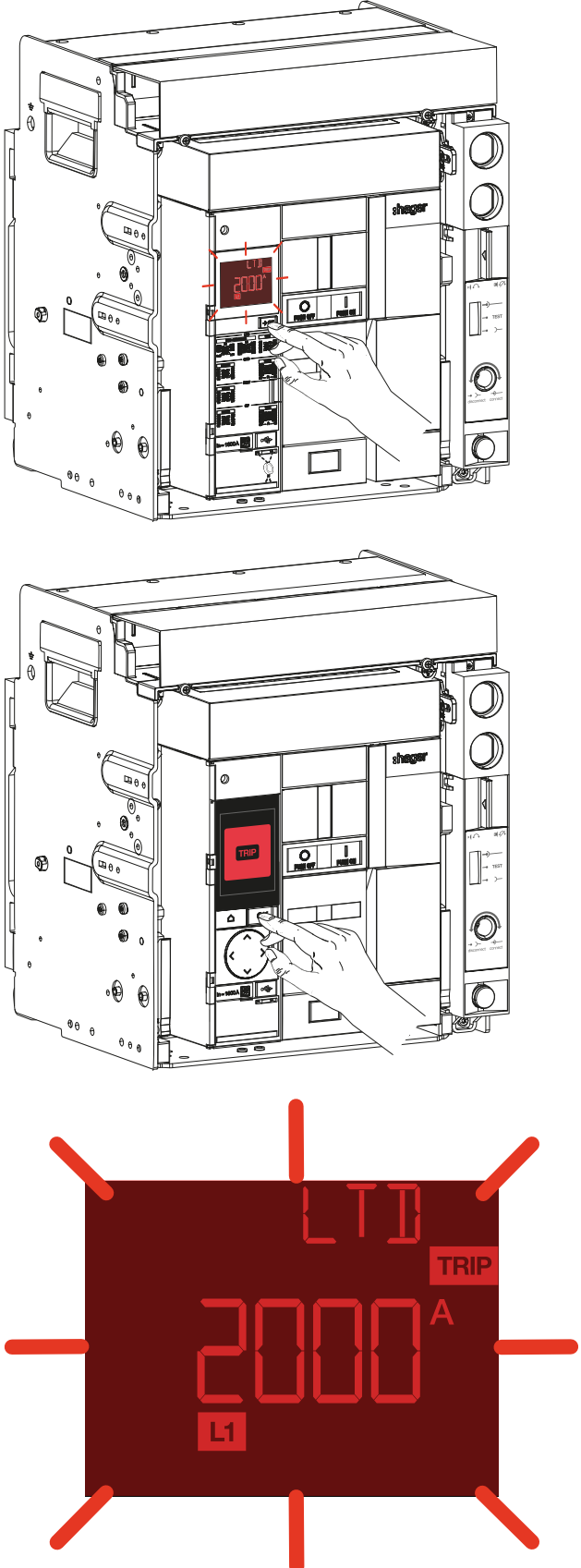
	Action	Illustration
<p>6 Then reset the trip unit display.</p> <p>Briefly press the button →OK for a sentinel trip unit</p> <p>and the button OK for a sentinel Energy trip unit.</p> <p>The sentinel trip unit display stops flashing:</p>		

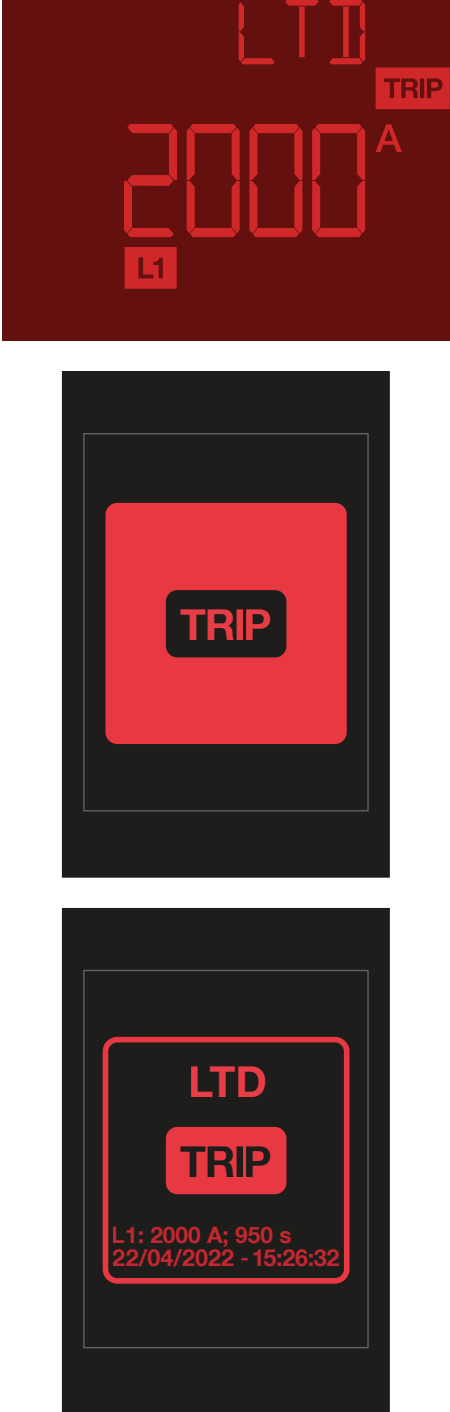
	Action	Illustration
6	<p>(continued) and becomes steady:</p> <p>The sentinel Energy trip unit display switches from this flashing message:</p> <p>To this flashing message.</p>	

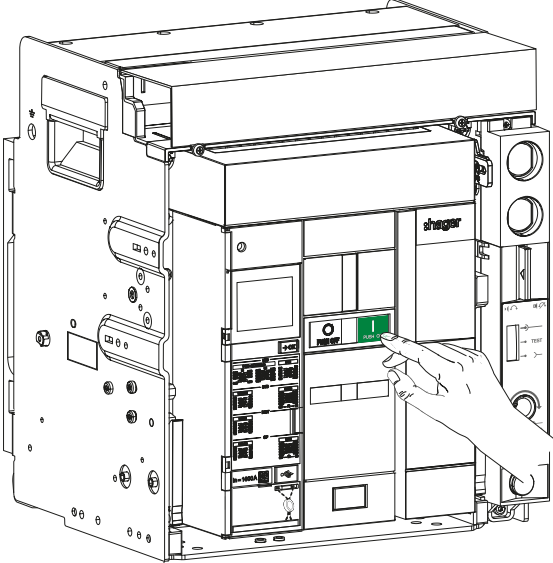
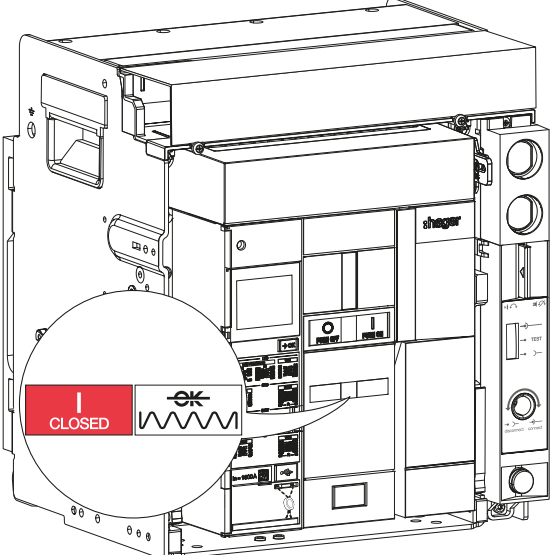
	Action	Illustration
9	Close the circuit breaker by pressing the closing push button 	
10	Check that the indicators change status.	

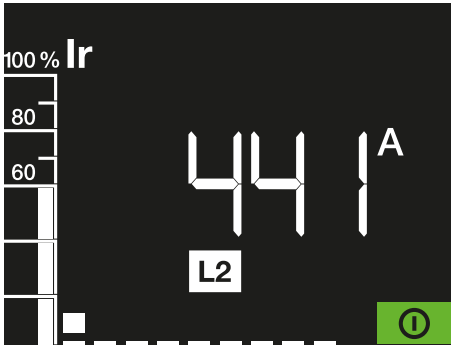
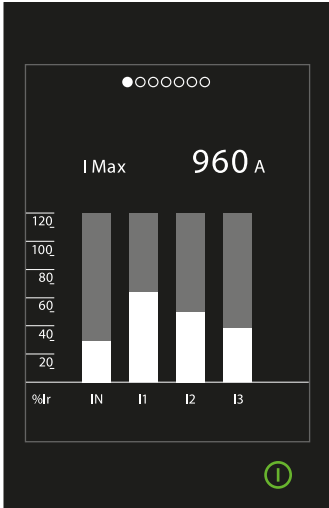
	Action	Illustration
11	<p>Verify that the ReadyToProtect indicator flashes on the sentinel trip unit display or that the ReadyToProtect indication light is lit on the sentinel Energy trip unit.</p> <p>If the display remains off, connect an external battery to the USB-C socket to perform this check.</p>	<p>sentinel Energy trip unit</p>  <p>sentinel Energy trip unit</p> 
ATTENTION		
<p>The trip unit must be powered in order for it to perform its protection functions. It is powered as long as a minimum current of 20% of the nominal current I_N passes through the circuit breaker.</p> <p>Nevertheless, it is strongly recommended that an external 24 V DC SELV power supply (recommended reference model Hager HTG911H) be connected to terminal block TU to guarantee optimal operation of the trip unit and prevent malfunctions in the electrical installation associated with a breach in the continuity of the trip unit operation.</p>		



Hager Electro SAS
132 Boulevard d'Europe
BP3
67210 OBERNAI CEDEX

www.hager.com