

# hw+

Air circuit breaker

HW1 / HW2 / HW4 / HW6

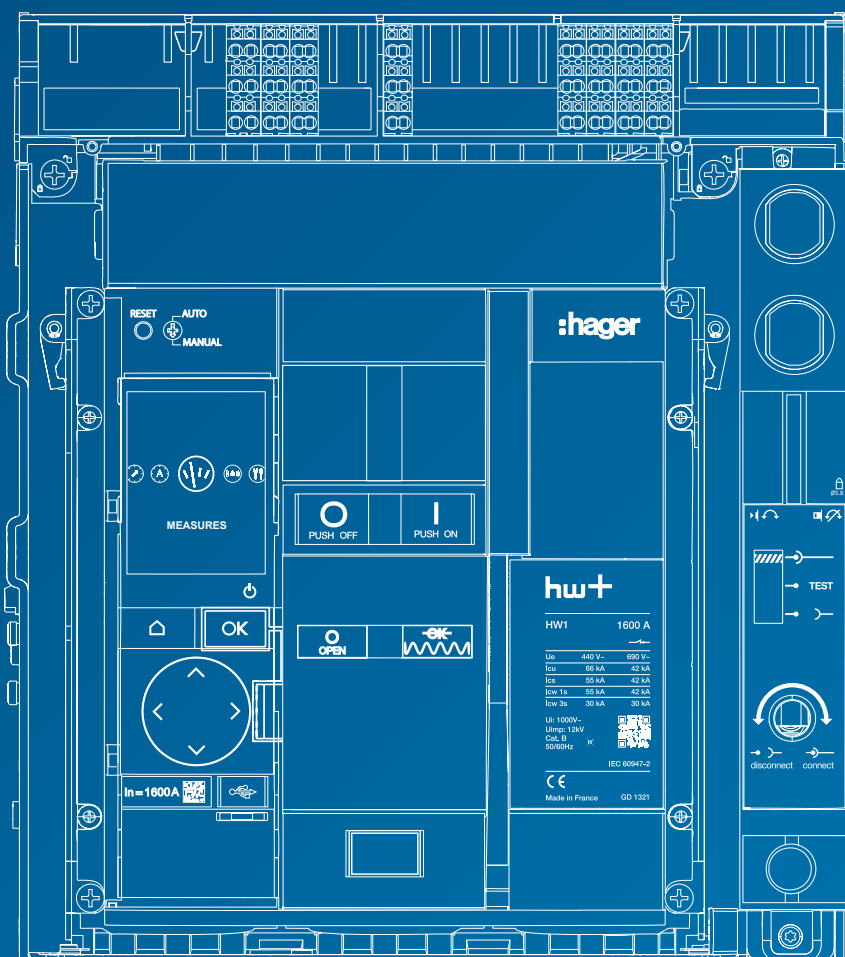

**DISCLAIMER:**

Whilst every effort has been made to ensure that the information is correct at the time of publication, Hager cannot guarantee the accuracy of all information contained in this document. Corrections and amendments, once verified, will be included in future editions.



<b>01 hw+ circuit breakers range</b>	5
General description, Key benefits hw+, Range overview	
<b>02 hw+ circuit breakers and switch disconnectors</b>	21
Selection guide, Technical specifications	
<b>03 sentinel electronic trip units</b>	45
General description, LI trip unit, LSI trip unit, LSIG trip unit	
<b>04 sentinel Energy electronic trip units</b>	55
General description, LSI trip unit, LSIG trip unit, Measurement function, Advanced protections	
<b>05 Configuration and referencing</b>	79
Configuration, Referencing, Testing and commissioning	
<b>06 Accessories</b>	85
List of accessories, Connection accessories, Control accessories, Signalling accessories, Locking and interlocking accessories, Power connection accessories, Protection accessories, Communication accessories	
<b>07 Installation and operating recommendations</b>	127
Installation and operating conditions, Safety clearances and minimum distances, Power loss	
<b>08 Dimensions</b>	139
Circuit breakers, Connections	
<b>09 Complementary characteristics</b>	179
Tripping curves, Thermal constraint and limitation curves	
<b>10 List of references</b>	205
Fixed version, Drawout version, Electronic trip units, Control accessories, Signalling accessories, Locking and interlocking accessories, Connection accessories, Protection accessories, Connection accessories, Communication accessories	
<b>11 Glossary</b>	237



<b>hw+ circuit breakers range</b>	<b>Page</b>
<b>01 General description</b>	<b>6</b>
<b>02 Key benefits hw+</b>	<b>10</b>
<b>03 Range overview</b>	<b>15</b>

The new generation of hw+ air circuit breakers and switch-disconnectors brings flexibility and ease in the choice of power protections at the core of electrical installations.

### Two trip units for two levels of use

The sentinel and sentinel Energy electronic trip units have distinctive dark backgrounds that allow the information displayed to be seen with great clarity. The icons and indicator lights following a precise colour code:

- Green: trip unit ready to perform its functions, particularly its protection functions,
- Orange: operating alert not requiring the circuit breaker to be tripped,
- Red: tripping imminent or serious malfunction

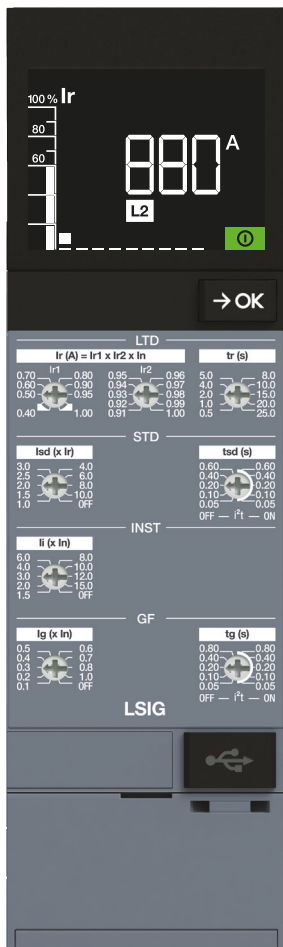

### sentinel electronic trip unit

Designed for limited use with the basic L, S, I, G settings, the sentinel electronic trip unit has a user interface with settings dials and an OK button enhanced by a colour LCD display. This displays the maximum instantaneous current flowing through the circuit breaker in real time.



### sentinel Energy electronic trip unit

In addition to basic LSIG protections, the sentinel Energy electronic trip unit offers advanced protection, alarm, measurement, monitoring and communication functions along with a keyboard and graphical display interface. The sentinel Energy trip unit allows a wireless Bluetooth Low Energy connection to be established with a smartphone using the Hager Power touch application.

### A new digital experience

The new generation of hw+ air circuit breakers and switch disconnectors is designed to facilitate interaction with digital tools at all stages of the installation project from design to commissioning and operation.

The Hager Power setup software allows all the protection setting values to be altered manually or in a controlled way by importing the electrical grid calculation values. A commissioning report can be generated once the commissioning has been carried out. This report provides proof that the settings of the hw+ circuit breaker are in accord with the requirements of the technical engineering department.

**Design**

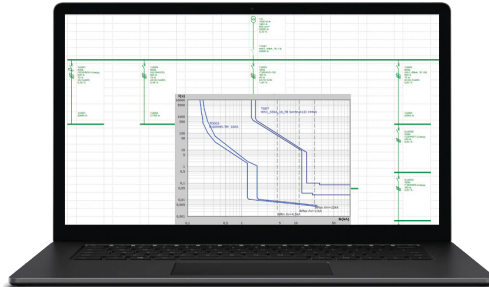

**Electrical network calculation software**  
Enables the selectivity between the different protection elements to be calculated in accordance with the assumed short-circuit values.

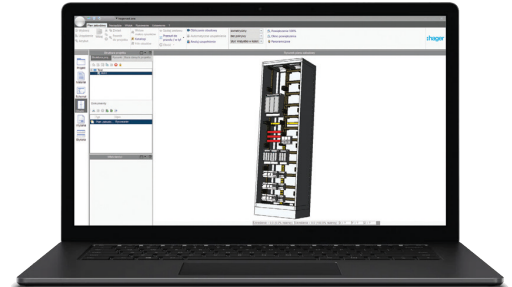

**Hagercad software**  
Software for the design and costing of electrical distribution boards up to 4000A.

**Configuration**

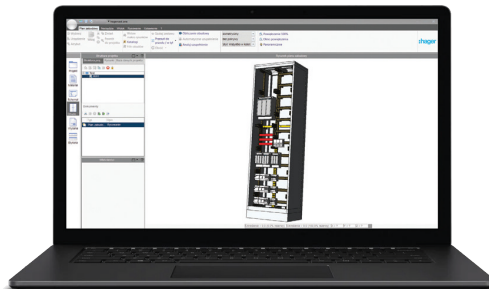

**Hagercad software**  
Allows hw+ circuit breakers and switch disconnectors to be configured.

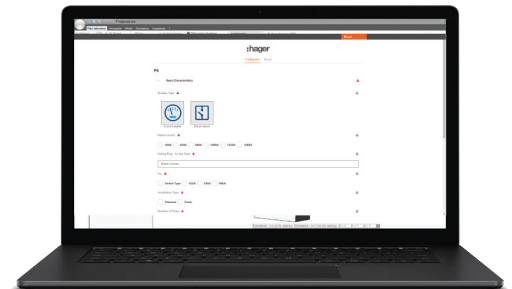

**hw+ WebConfigurator**  
Allows hw+ circuit breakers and switch disconnectors to be configured.

**Installation and commissioning**

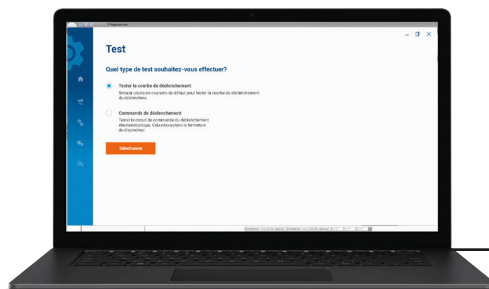

**Hager Power setup software**  
Test the settings of the hw+ circuit breakers and generate a commissioning report proving that the settings conform with the values defined in Hagercad.

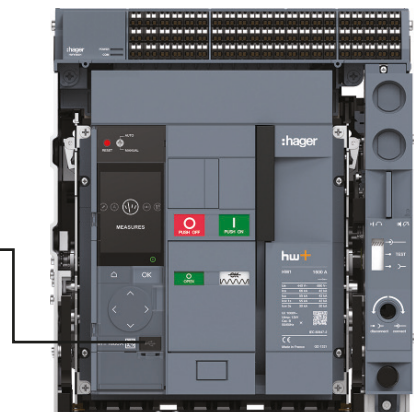

### Extended digital experience with the sentinel Energy trip unit

hw+ circuit breakers equipped with the sentinel Energy electronic trip unit offer even more benefits.

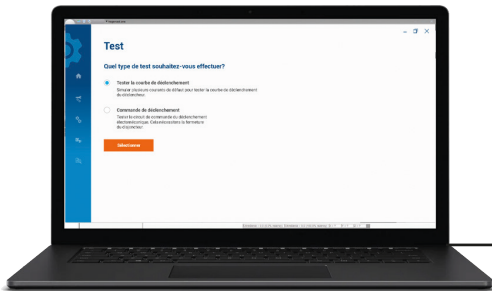

#### Hager Power setup software

Improve efficiency during commissioning by using the Hager Power setup software to adjust settings and perform test tripping of the circuit breaker.

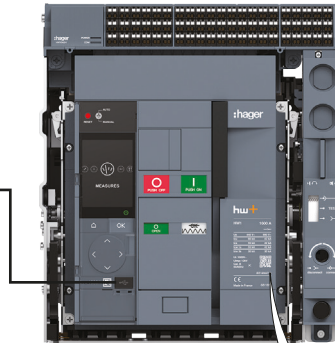

#### Hager Power touch application

User Hager Power touch from your smartphone to monitor the status, measurement and alert information provided by the sentinel Energy trip unit. Take control of the circuit breaker and remain at a safe distance while it is recommissioned.



#### Access the documentation online

Scan the QR code from your smartphone to access information and technical documents online.

### Class 1 measurement accuracy with the sentinel Energy trip unit

The hw+ circuit breaker equipped with the sentinel Energy electronic trip unit and integrated measurement sensors constitutes a PMD-DD class measurement device in accordance with the standard IEC/EN 61557-12.

The measurement accuracy reaches class 0.5 for voltage and current measurements, and class 1 for power and active energy measurements.

For each measurement, the accuracy is certified within a temperature range from -25 °C to 70 °C, taking into account all the specific errors of the components belonging to the measurement chain.

It is available in four sizes: HW1, HW2, HW4 and HW6, available in 3-pole and 4-pole fixed and drawout versions.

HW1 is of compact size available from 400A to 1600A.

HW2 is available from 630 A to 2500 A.

HW4 is available from 1000 A to 4000 A.

HW6 is available in 6300 A version.

The range offers high-performance protection with a breaking capacity up to 120 kA.

**The hw+ circuit breaker is available in four sizes:**

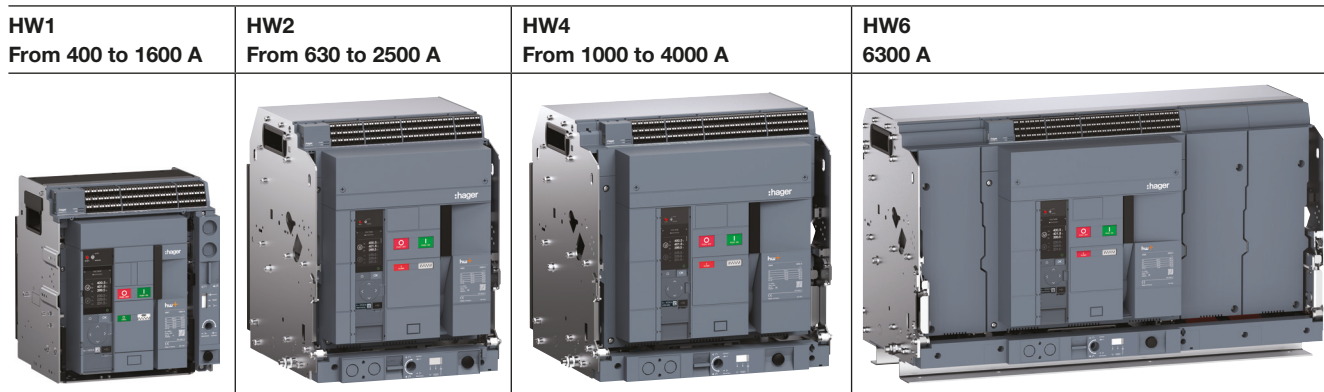

		Nominal current (In)													
		Icu	400 A	630 A	800 A	1000 A	1250 A	1600 A	2000 A	2500 A	3200 A	4000 A	5000 A	6300 A	
<b>HW1</b>	N: 42 kA		█												
	M: 55 kA		█												
	E: 66 kA		█												
<b>HW2</b>	M: 55 kA		█												
	E: 66 kA		█												
	S: 100 kA		█												
<b>HW4</b>	E: 66 kA				█										
	S: 85 kA				█										
	P: 120 kA				█										
<b>HW6</b>	L: 100 kA										█ (1)		█		

(1) Via the use of a suitable calibrator

### Customise your sentinel Energy trip unit

The sentinel Energy trip unit has a TFT graphical display allowing your favourite views to be displayed in Live mode. It also allows up to 12 individual optional alarms to be programmed, according to your requirements.

#### Live mode

Live mode allows up to 15 favourite views to be continuously displayed among a list of 27 views available. These are views of measured values or protection setting values.

#### Customised alarms

Up to 12 optional alarms can be configured, offering you personalised monitoring to detect any threshold breach or unusual measurement by the trip unit. You can choose the types of measurements you want to monitor, such as voltage, current, etc., and be warning immediately by a message window if something unusual happens.

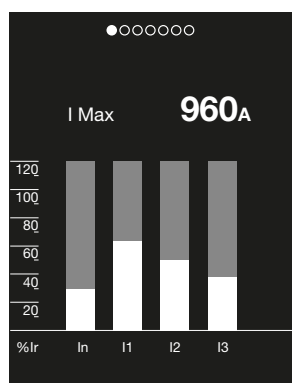

Ammeter view

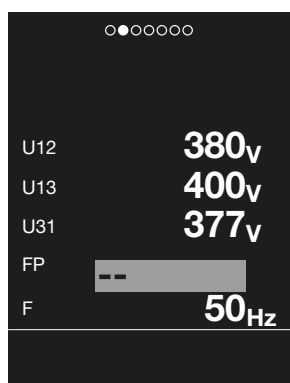

Multimeter view



Example of overshoot on single voltage V1N.

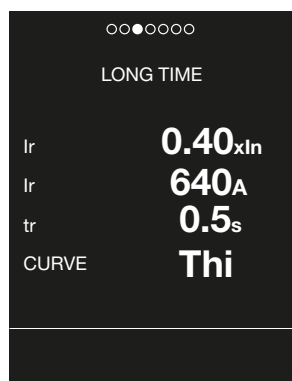
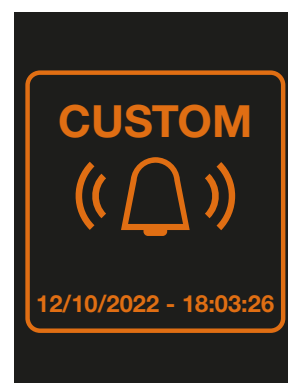

Long time delay view

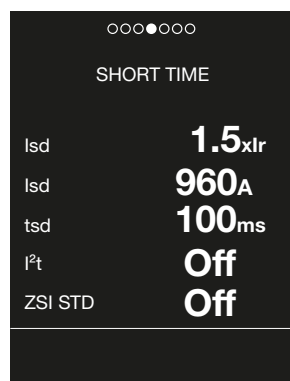

Short time delay view



**Benefit from the sentinel trip unit's dynamic display**

The sentinel trip unit's dynamic LCD display makes commissioning, operation and maintenance of your circuit breaker easier.

**Dynamic settings display**

For Settings, the LCD display gives a precise indication of the setting values entered in amps and seconds.

Its high contrast allows easy reading of the settings whether in a dark or bright environment.

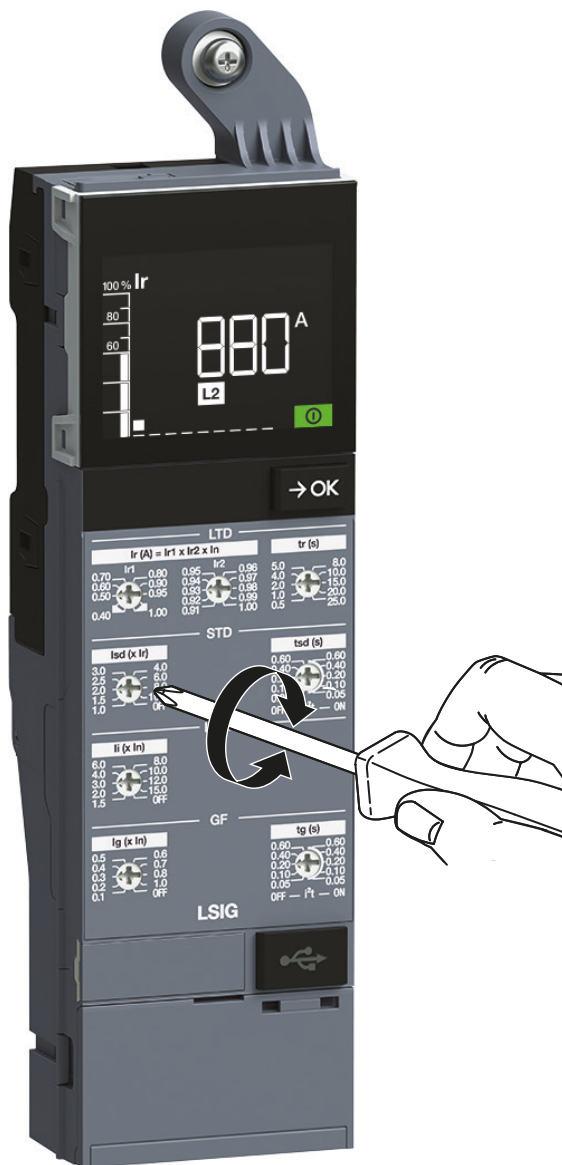

**Dynamic load display**

The main screen displays the maximum current flowing through the circuit breaker for the phase concerned.

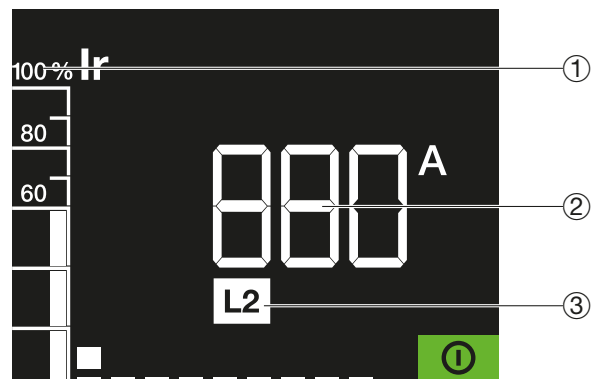

- ① Value of the current flowing through the circuit breaker as % of Ir
- ② Value of the current flowing through the circuit breaker
- ③ Relevant phase

**See the trip cause**

After tripping, a detailed message indicates the reasons why it happened.

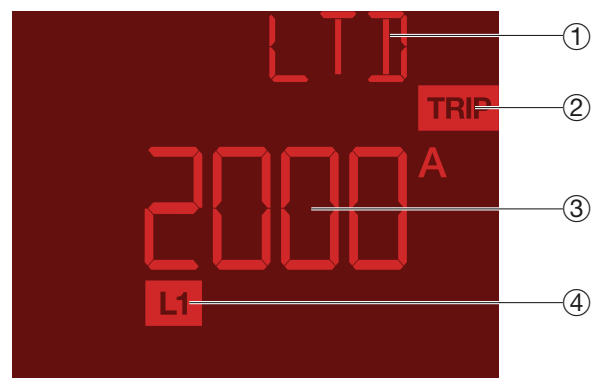

- ① Trip cause
- ② Trip icon
- ③ Fault current value
- ④ Phase concerned

**Settings viewable at all times**

The OK button on the electronic trip unit allows switching between screens displaying all possible settings of the electronic trip unit.

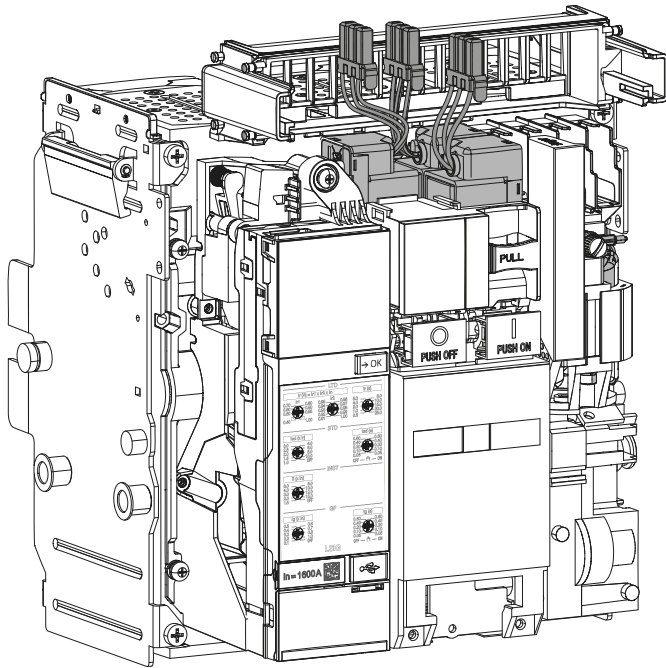

#### Quick and secure fitting of coils

Thanks to a patented lock system the opening and closing coils can be installed without tools and stay firmly in place.

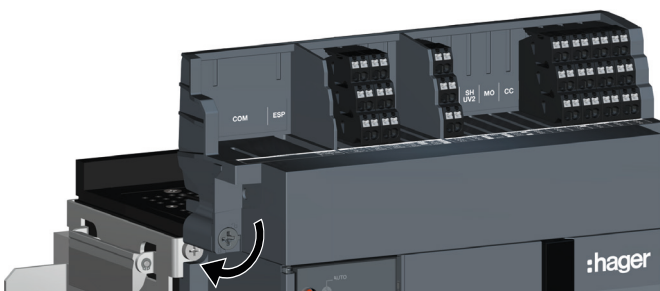

#### Quick access to the connection terminal block

To access the connection terminal block for the various auxiliaries, just turn the screw on the terminal block cover of the fixed circuit breakers through a quarter turn.

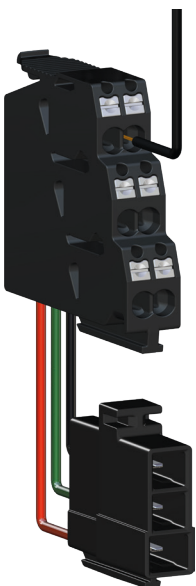

#### QuickConnect system for faster wiring of accessories

A connection terminal block is available to connect the various accessories to the circuit breaker. These connections are made with the QuickConnect feature.

- saves time: thanks to the QuickConnect technology, wiring is quick, easy and tool-free
- safer: cable connection is ensured.
- test point: used to check for the presence of voltage with a voltmeter.
- cable disconnection: the QuickConnect terminal can be released quickly and easily with a screwdriver

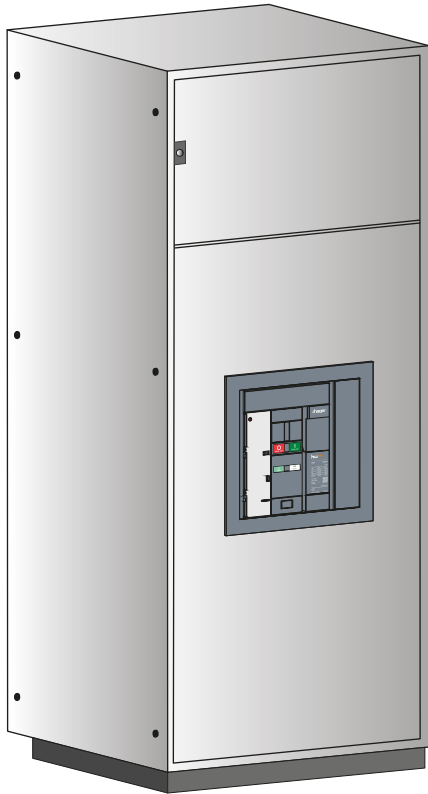

**Quick-to-mount door flange (DF)**

The door flange of the hw+ range includes clamps at the back, enabling quick, tool-free installation. It's also no longer necessary to create holes on the board door of the cabinet, saving time and effort.

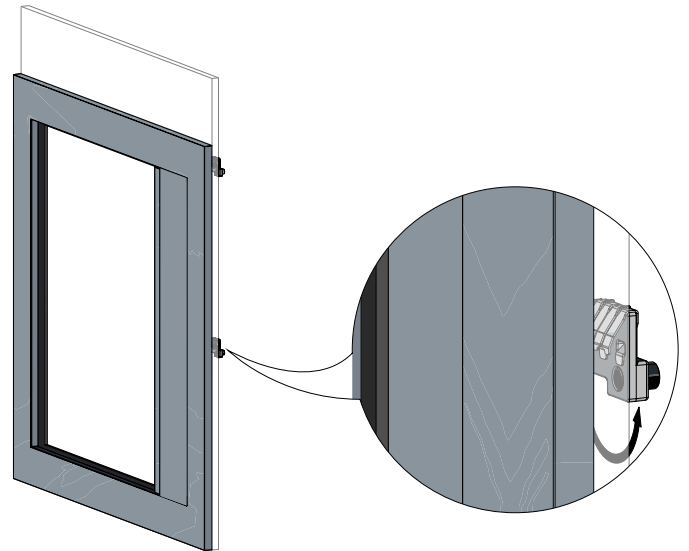

**Quick and easy installation of the key locks**

The installation of key locks on the front of the circuit breaker is very easy. A single screw is enough to mount the OFF Locking Key (OLK) accessory on the front of the circuit breaker.

This accessory is used to lock the OFF Button or to have an interlocking between several circuit breakers.

This function can also be achieved using padlocks (1 to 3 locks) by installing the OFF Locking Padlock (OLP) accessory on the front of the circuit breaker.

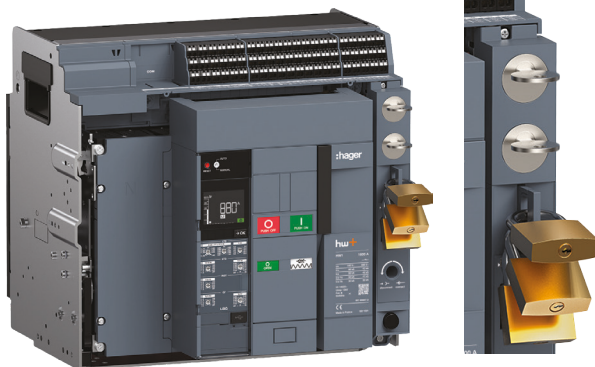

The chassis position locking system (CL), which is located on the chassis, offers the possibility of installing up to 2 cylindrical key locks.

This accessory can be used to lock the circuit breaker (moving part) in the Connected, Test or Disconnected position inside its chassis.

Locking can also be done using 1 to 3 padlocks with the tab located below.

### Programmable output contacts



The OAC output contacts module has 5 alarm output contacts.

It integrates fully into the circuit breaker and does not require any external terminal.

The OAC contacts are assigned permanently to the following events on a circuit breaker equipped with the sentinel trip unit:

- LTD tripping,
- STD/INST/MCR tripping,
- GF tripping,
- overload pre-alarm,
- tripping due to a critical system alarm.

The assignment of OAC contacts is programmable on a circuit breaker equipped with a sentinel Energy trip unit.

Each OAC contact cannot be reassigned to a distinct trip, alarm or operational event, chosen from a predefined list offering more than 40 options.





The OAC contacts with a sentinel Energy trip unit are assigned by default to the following events:

- LTD tripping,
- grouped alarm (configured to STD, INST or MCR tripping),
- GF tripping,
- overload pre-alarm,
- tripping due to a critical system alarm.





	With the sentinel trip unit	With the sentinel Energy trip unit
OAC contacts 1 to 5	Non-programmable	Programmable

The hw+ range is equipped with circuit breakers and switch-disconnectors.  
The circuit breakers have an electronic trip unit.  
The switch-disconnectors do not have an electronic trip unit.



**HW1 circuit breakers**

Fixed version		Drawout version	
3 poles	4 poles	3 poles	4 poles
			



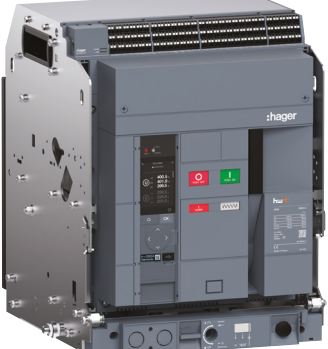
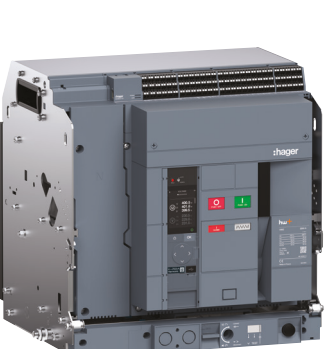

**HW1 switch-disconnectors**

Fixed version		Drawout version	
3 poles	4 poles	3 poles	4 poles
			

## HW2 circuit breakers

Fixed version		Drawout version	
3 poles	4 poles	3 poles	4 poles
			

## HW2 switch-disconnectors

Fixed version		Drawout version	
3 poles	4 poles	3 poles	4 poles
			



### HW4 circuit breakers

Fixed version

Drawout version

Available in 3- and 4-poles

Available in 3- and 4-poles



### HW4 switch-disconnectors

Fixed version

Drawout version

Available in 3- and 4-poles

Available in 3- and 4-poles

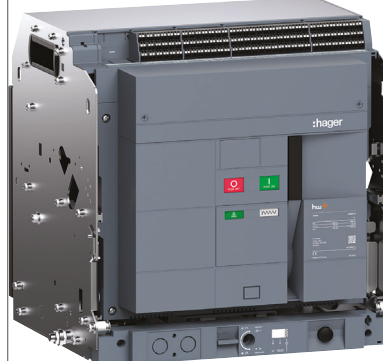

## HW6 circuit breakers

Drawout version  
3 poles



4 poles

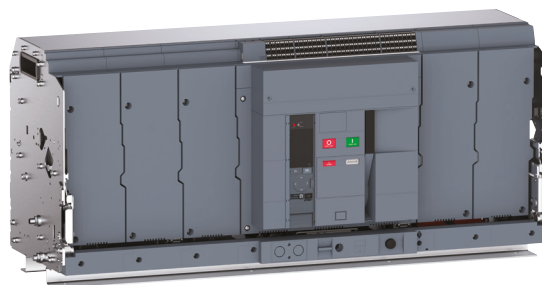

## HW6 switch-disconnectors

Drawout version  
3 poles



4 poles





**Accessories**

Control accessories



Signalling accessories



Interlocking accessories



With connection accessories

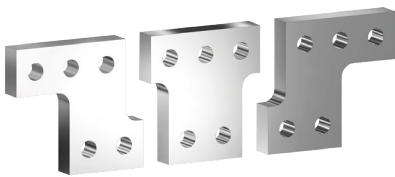

Protection accessories

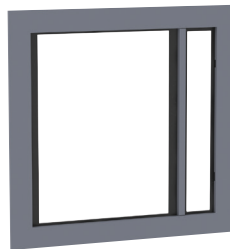

Communication accessories



**sentinel electronic trip units**

LI



LSI



LSIG



**sentinel Energy electronic trip units**

LSI



LSIG



## Integration in electrical distribution boards

The hw+ circuit breakers and switch-disconnectors are generally used in electrical assemblies located at the core of low-voltage electrical installations.

HW1 circuit breakers and switch-disconnectors can be installed in Unimes, Univers and Quadro distribution board systems.

HW2 and HW4 circuit breakers and switch-disconnectors can be installed in Unimes H and Quadro distribution board systems.



# hw+ circuit breakers and switch disconnectors Page

---

01 Selection guide	23
02 Technical specifications	29

---



## Important parameters of the air circuit breakers

Rated current In (A)	This is the maximum value of current that the circuit breaker can permanently withstand. This value is always stated for an ambient temperature (50 °C) in accordance with standard IEC 60947-2. If this temperature is higher, the operating current must be reduced.
Rated operational voltage Ue (V)	This is the voltage at which the circuit breaker has been designed to operate, in normal operating conditions. The value provided is usually the maximum value.
Rated insulation voltage Ui (V)	This value indicates the insulation performance of the device. The dielectric test voltages (power frequency, impulse) are established based on this value.
Impulse withstand voltage Uimp (kV)	This value indicates the capacity of the device to withstand transient overvoltages such as lightning.
Rated ultimate short-circuit breaking capacity Icu (kA)	This is the maximum short circuit current that a circuit breaker can break for a given voltage and phase angle without being damaged. The tests are performed using the sequence O – t – CO. O represents an automatic tripping operation, t an interval of time and CO a closing operation followed by an automatic tripping operation. After the test, the circuit breaker must continue to provide a minimum level of safety (insulation, dielectric strength).
Rated operational short-circuit breaking capacity Ics (kA)	This value is expressed in kA or as a percentage of Icu. The circuit breaker must be able to function normally after having cleared the Ics current three times according to the sequence O-t-CO-t-CO.
Rated short-time withstand current Icw (kA)	This is the short circuit current that a category B circuit breaker is able to withstand for a defined period of time without altering its characteristics. This value is intended to provide discrimination between upstream and downstream devices. The circuit breaker in question can remain closed while the fault is cleared by the downstream device.
Rated short-circuit making capacity Icm (kA peak)	This is the maximum current value that a device can establish at its rated voltage under standard conditions.

hw+ circuit breakers		HW1 size			
Reference			HW1N... 42 kA	HW1M... 55 kA	HW1E... 66 kA
Rated current at 50°C	(A)	HW1xx04...	400	400	400
		HW1xx06...	630	630	630
		HW1xx08...	800	800	800
		HW1xx10...	1000	1000	1000
		HW1xx12...	1250	1250	1250
		HW1xx16...	1600	1600	1600
Selectivity category according to IEC 60947-2		-	B	B	B
Rated ultimate short-circuit breaking capacity (kA) Icu		380-415 V CA	42	55	66
		440 V AC	42	55	66
		500-525 V CA	42	42	42
		690 V AC	42	42	42
Rated operational short-circuit breaking capacity	(% Icu) Ics	-	100	100	100 <sup>(1)</sup>
Short-time withstand current rating capacity	(kA) Icw	1s - 400 V CA	42	55	55
		3s - 400 V CA	24	24	30
sentinel trip unit		-	Yes	Yes	Yes
sentinel Energy trip unit		-	Yes	Yes	Yes
Connection	Drawout	front connections	Yes	Yes	Yes
	Drawout	rear connections	Yes	Yes	Yes
	Fixed	front connections	Yes	Yes	Yes
	Fixed	rear connections	Yes	Yes	Yes
Dimensions (max. value in mm) Width x height x depth	a x b x c	Drawout 3-pole	284 x 322 x 328		
		Drawout 4-pole	349 x 322 x 328		
		Fixed 3-pole	276 x 313 x 227		
		Fixed 4-pole	346 x 313 x 227		

- (1) Ics: 55 kA for voltages 380 to 440 V  
 (2) Ics: 85 kA for voltages 380 to 440 V  
 (3) Ics: 100 kA for voltages 380 to 440 V

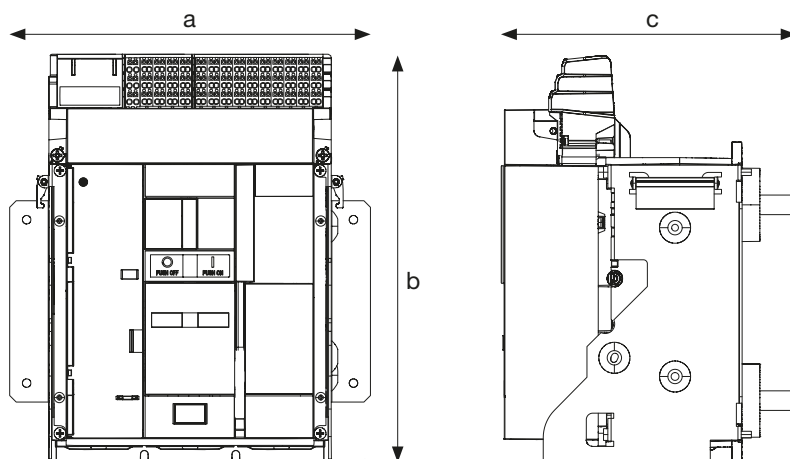

HW2 size				HW4 size			
	HW2M... 55 kA	HW2E... 66 kA	HW2S... 100 kA		HW4E... 66 kA	HW4S... 85 kA	HW2P... 120 kA
HW2xx06...	630	630	630	HW4xx10...	1000	1000	1000
HW2xx08...	800	800	800	HW4xx12...	1250	1250	1250
HW2xx10...	1000	1000	1000	HW4xx16...	1600	1600	1600
HW2xx12...	1250	1250	1250	HW4xx20...	2000	2000	2000
HW2xx16...	1600	1600	1600	HW4xx25...	2500	2500	2500
HW2xx20...	2000	2000	2000	HW4xx32...	3200	3200	3200
HW2xx25...	2500	2500	2500	HW4xx40...	4000	4000	4000
-	B	B	B	-	B	B	B
-	55	66	100	-	66	85	120
-	55	66	100	-	66	85	120
-	42	55	66	-	66	75	85
-	42	55	66	-	66	75	85
-	100	100	100 <sup>(2)</sup>	-	100	100	100 <sup>(3)</sup>
-	55	66	85	-	66	85	85
-	36	50	66	-	66	66	75
-	Yes	Yes	Yes	-	Yes	Yes	Yes
-	Yes	Yes	Yes	-	Yes	Yes	Yes
-	-	-	-	-	-	-	-
-	Yes	Yes	Yes	-	Yes	Yes	Yes
-	-	-	-	-	-	-	-
-	Yes	Yes	Yes	-	Yes	Yes	Yes
-	400 x 450 x 465			-	493 x 450 x 465		
-	495 x 450 x 465			-	619 x 450 x 465		
-	385 x 416 x 373			-	478 x 416 x 373		
-	480 x 416 x 373			-	604 x 416 x 373		

hw+ circuit breakers and switch disconnectors

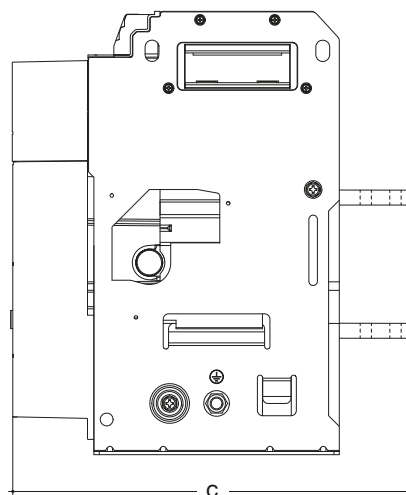
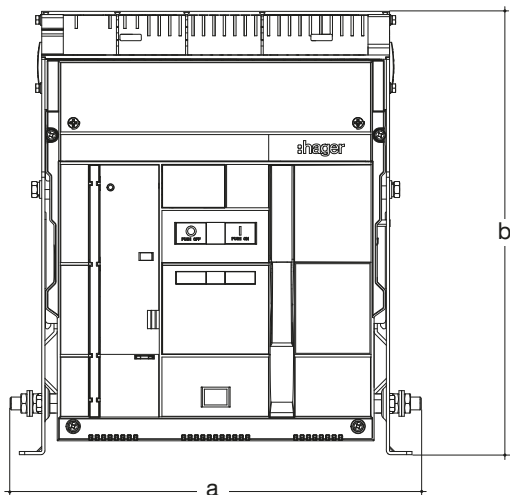

hw+ circuit breakers		HW6 size	
Reference			HW6L 100 kA
Rated current at 50°C	(A)	HW6xx <b>63</b> ...	6300
Selectivity category according to IEC 60947-2		-	B
Rated ultimate short-circuit breaking capacity (kA) Icu		380-415 V CA	150
		440 V AC	150
		500-525 V CA	100
		690 V AC	100
Rated operational short-circuit breaking capacity	(% Icu) Ics	-	100 (4)
Short-time withstand current rating capacity (kA) Icw		1s - 400 V CA	100
		3s - 400 V CA	75
sentinel trip unit		-	Yes
sentinel Energy trip unit		-	Yes
Connection	Drawout	rear connections	Yes
Dimensions (max. value in mm) Width x height x depth	a x b x c	Drawout 3-pole	871 x 490 x 514
		Drawout 4-pole	1123 x 490 x 514

(1) Ics: 55 kA for voltages 380 to 440 V

(2) Ics: 85 kA for voltages 380 to 440 V

(3) Ics: 100 kA for voltages 380 to 440 V

(4) Ics: 150 kA for voltages 380 to 440 V



hw+ switch-disconnectors		HW1 size		HW2 size		HW4 size	
Reference		HW1W		HW2W		HW4W	
Rated current at 50°C	(A)	HW1Wx04...	400	HW2Wx06...	630	HW4Wx10...	1000
		HW1Wx06...	630	HW2Wx08...	800	HW4Wx12...	1250
		HW1Wx08...	800	HW2Wx10...	1000	HW4Wx16...	1600
		HW1Wx10...	1000	HW2Wx12...	1250	HW4Wx20...	2000
		HW1Wx12...	1250	HW2Wx16...	1600	HW4Wx25...	2500
		HW1Wx16...	1600	HW2Wx20...	2000	HW4Wx32...	3200
				HW2Wx25...	2500	HW4Wx40...	4000
Utilization category according to IEC 60947-3		-	AC-23A	-	AC-23A	-	AC-23A
Short-time withstand current rating capacity	(kA) I <sub>cw</sub>	1s - 400 V CA	55	-	66	-	85
Rated short-circuit making capacity	(kA peak) I <sub>cm</sub>	380-415 V CA	121	-	145	-	187
		440 V AC	121	-	145	-	187
		500-525 V CA	88	-	145	-	187
		690 V AC	88	-	145	-	187
Connection	Drawout	front connections	Yes	-	-	-	-
	Drawout	rear connections	Yes	-	Yes	-	Yes
	Fixed	front connections	Yes	-	-	-	-
	Fixed	rear connections	Yes	-	Yes	-	Yes
Dimensions (max. value in mm) Width x height x depth	a x b x c	Drawout 3-pole	284 x 322 x 328	-	400 x 450 x 465	-	493 x 450 x 465
		Drawout 4-pole	349 x 322 x 328	-	495 x 450 x 465	-	619 x 450 x 465
		Fixed 3-pole	276 x 313 x 227	-	385 x 416 x 373	-	478 x 416 x 373
		Fixed 4-pole	346 x 313 x 227	-	480 x 416 x 373	-	604 x 416 x 373

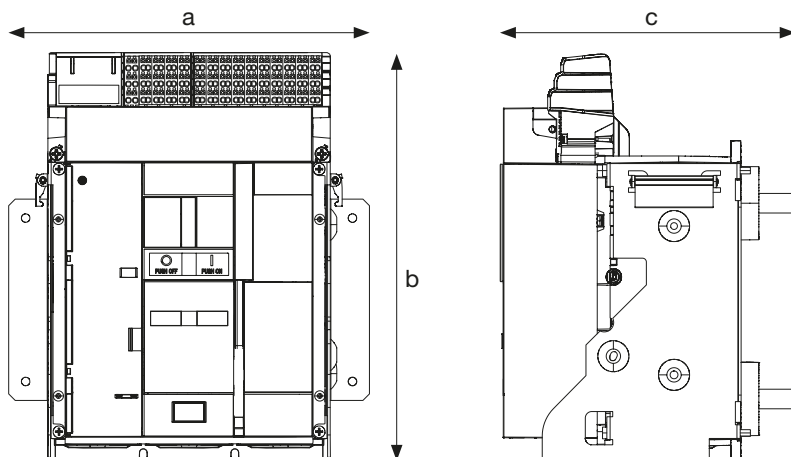

hw+ switch-disconnectors		HW6 size	
Reference		HW6W	
Rated current at 50°C (A)		HW6xx63...	6300
Utilization category according to IEC 60947-3		-	B
Short-time withstand current rating capacity (kA) $I_{cw}$		1s - 400 V CA	100
Rated short-circuit making capacity (kA peak) $I_{cm}$		380-415 V CA	330
		440 V AC	330
		500-525 V CA	220
		690 V AC	220
Connection	Drawout	front connections	-
	Drawout	rear connections	Yes
Dimensions (max. value in mm) Width x height x depth	a x b x c	Drawout 3-pole	871 x 490 x 514
		Drawout 4-pole	1123 x 490 x 514

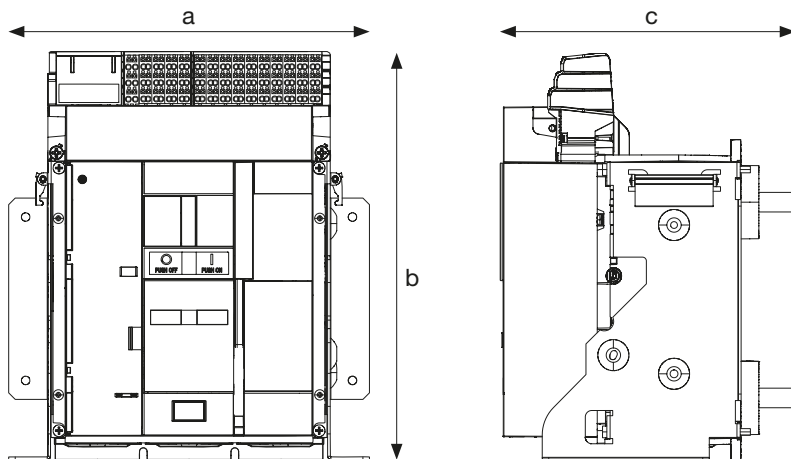

Front view of the circuit breakers and switch-disconnectors

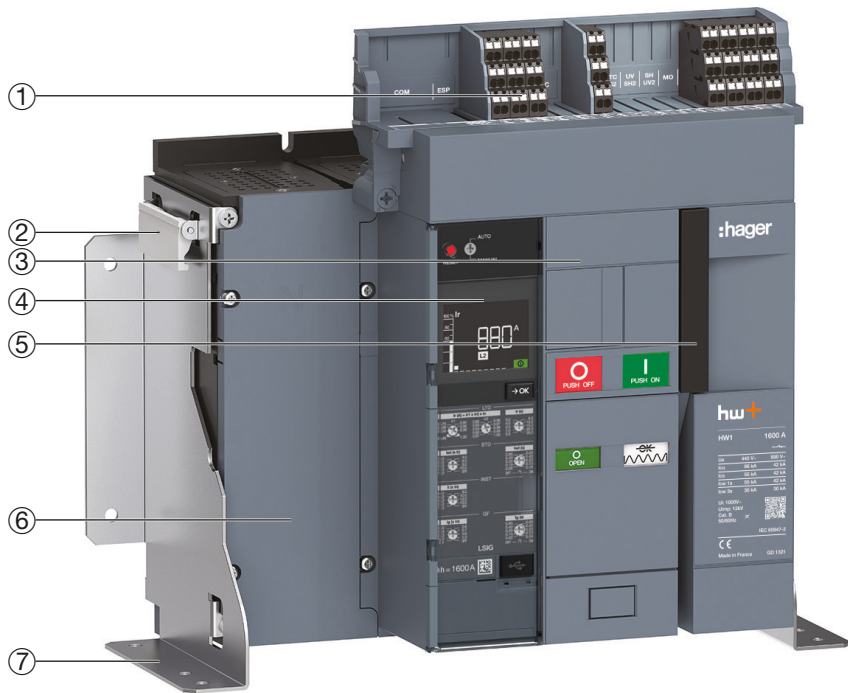

Example of a fixed type 4-pole circuit breaker

- ① Terminal blocks TB
- ② Lifting handle
- ③ Front cover
- ④ Electronic trip unit
- ⑤ Charging handle
- ⑥ Neutral pole position
- ⑦ Fastening plate



Example of a drawout type 3-pole circuit breaker outside its chassis

hw+ circuit breakers and switch disconnectors

Front view of the chassis

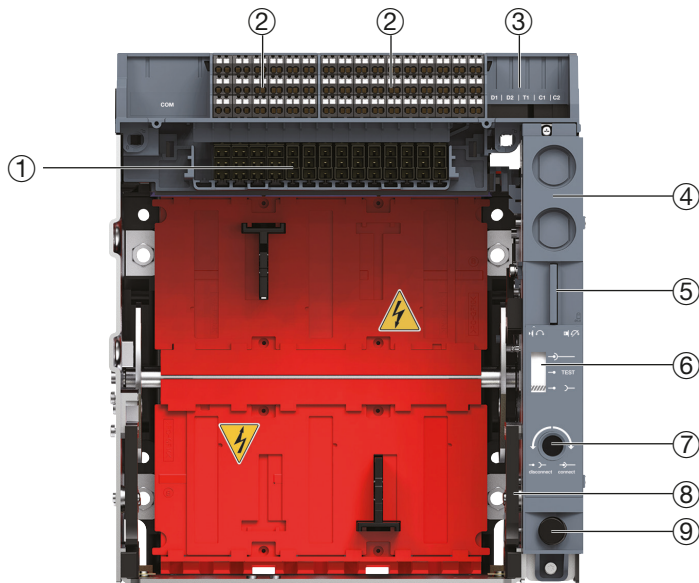

Chassis for HW1 drawout circuit breaker

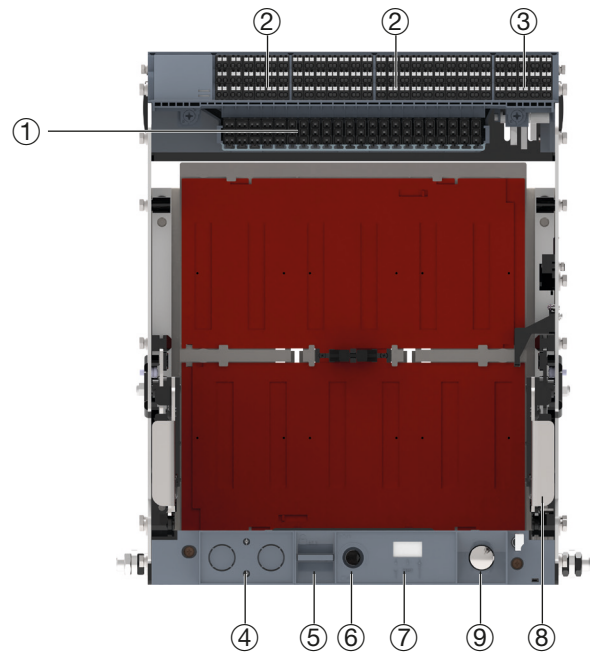

Chassis for HW2 and HW4 drawout circuit breaker

- ① Connection interface
- ② Terminal blocks TB
- ③ Slots for position contacts
- ④ Locking of the circuit breaker position using CL key locks
- ⑤ Locking of the circuit breaker by padlock in the Connected, Test or Disconnected position and position acknowledgement button
- ⑥ Position indicator
- ⑦ Place to insert the racking handle
- ⑧ Guide rail
- ⑨ Rack-in/rack-out handle storage

Rear view of the chassis

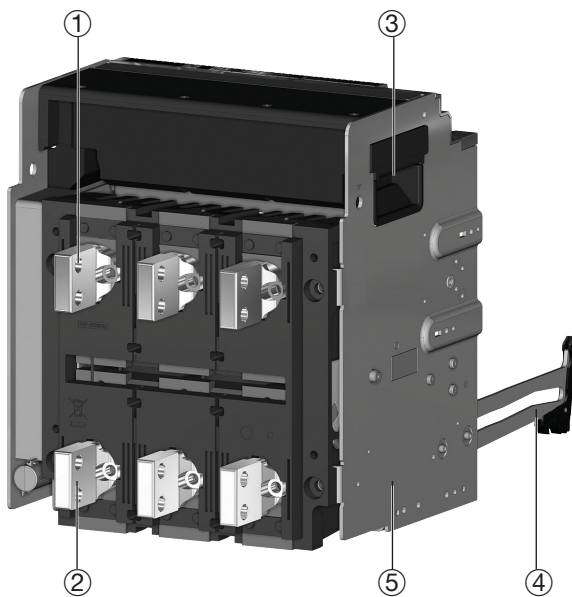

Chassis for HW1 drawout circuit breaker

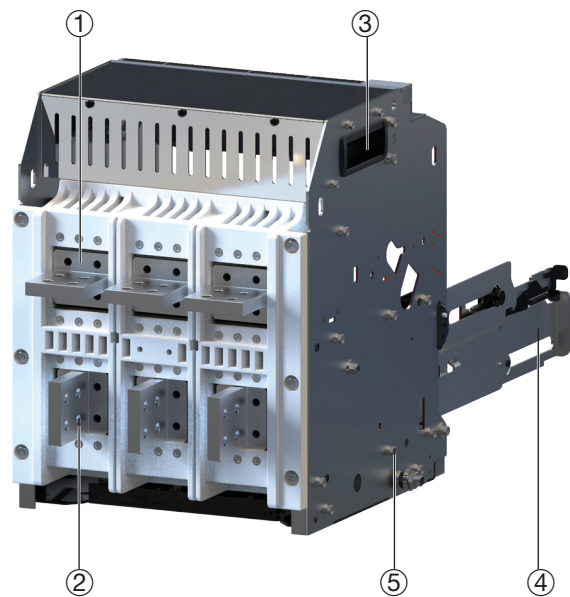

Chassis for HW2 and HW4 drawout circuit breaker

- ① Top connection
- ② Bottom connection
- ③ Lifting handle
- ④ Guide rail
- ⑤ Side plate

Front view of the circuit breaker

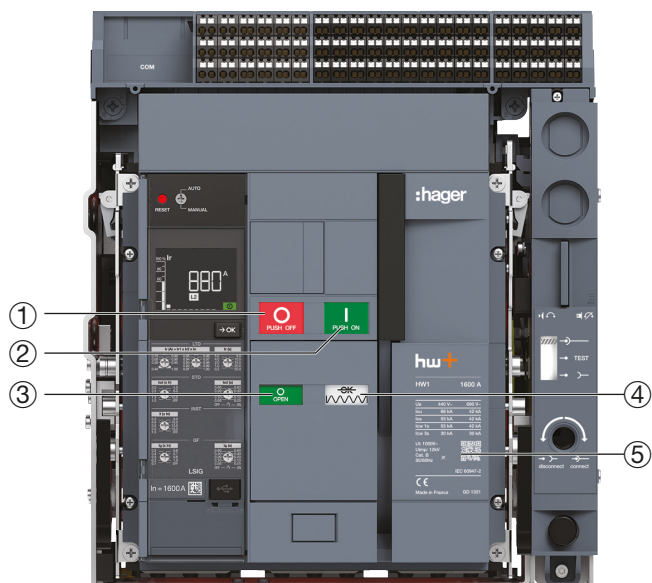

- ① OFF push button
- ② ON push button
- ③ Contact opening and closing indicator
- ④ Charging spring status indicator
- ⑤ Type label

Example of a 3-pole drawout circuit breaker

hw+ circuit breakers and switch disconnectors

View of the sentinel electronic trip unit

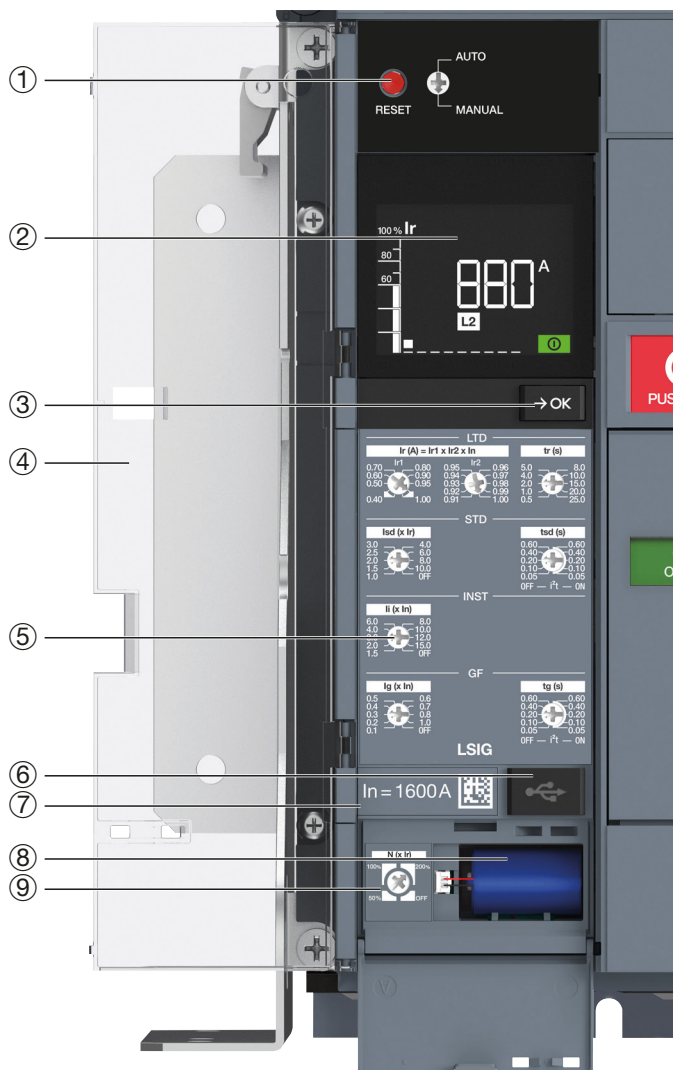

- ① RESET re-arm button
- ② LCD display
- ③ OK button
- ④ Trip unit cover
- ⑤ Settings dials
- ⑥ USB-C port
- ⑦ Rating plug
- ⑧ Backup battery
- ⑨ Neutral protection settings dial

The RESET re-arm button configured in MANUAL is used to locally reset the circuit breaker after tripping. Configured in AUTO the circuit breaker is reset automatically after each tripping operation.

Example of a sentinel LSIG electronic trip unit



View of the sentinel Energy electronic trip unit



- ① RESET re-arm button
- ② LCD display
- ③ Trip unit cover
- ④ OK button
- ⑤ Home button
- ⑥ Navigation buttons
- ⑦ USB-C port
- ⑧ Rating plug
- ⑨ Backup battery

The RESET re-arm button configured in MANUAL is used to locally reset the circuit breaker after tripping. Configured in AUTO the circuit breaker is reset automatically after each tripping operation.

Example of a sentinel Energy LSIG electronic trip unit

#### Type label

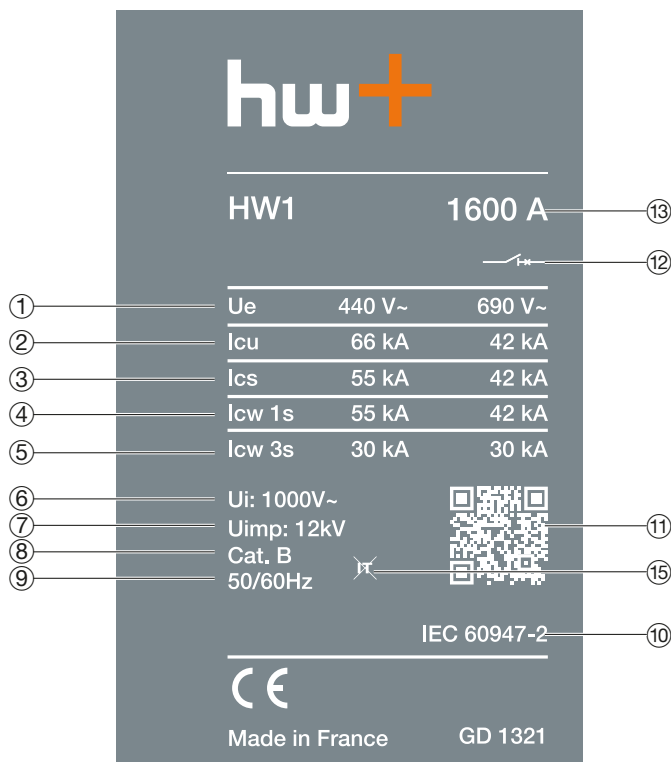

- ① Ue: Operating voltage
- ② Icu: Rated ultimate short-circuit breaking capacity
- ③ Ics: Rated operational short-circuit breaking capacity
- ④ Icw 1 s: Rated short-time withstand current for 1 second
- ⑤ Icw 3s: Rated short-time withstand current for 3 seconds
- ⑥ Ui: Rated insulation voltage
- ⑦ Uimp: Rated impulse withstand voltage
- ⑧ Selectivity category
- ⑨ Frequency
- ⑩ Standards
- ⑪ QR code to access the documentation online
- ⑫ Symbol of a circuit breaker suitable for disconnection or symbol of a switch-disconnector
- ⑬ Maximum rating of the circuit breaker
- ⑭ Icm: Rated short-circuit making capacity
- ⑮ Not suitable for protection in an IT earthing system

#### Breaking capacity classification:

	Icu (380-440 VAC)			
	HW1	HW2	HW4	HW6
N	42 kA	-	-	-
M	55 kA	55 kA	-	-
E	66 kA	66 kA	66 kA	-
S	-	100 kA	85 kA	-
P	-	-	120 kA	-
L	-	-	-	150 kA

#### Compliant with standards

The hw+ circuit breakers and the related auxiliary devices comply with the following standards:

##### International standards:

- IEC 60947-1: general rules
- IEC 60947-2: circuit breakers
- IEC 60947-3: switch-disconnectors
- IEC 60947-5-1: control circuit devices and switching elements

##### European standards:

- EN 60947-1: general rules
- EN 60947-2: circuit breakers
- EN 60947-3: switch-disconnectors
- EN 60947-5-1: control circuit devices and switching elements

##### National standards:

- China CCC, GB/T140248.2
- China CCC, GB/T140248.3
- China CCC, GB/T140248.1

#### Pollution degree

hw+ circuit breakers are certified for operation in environments with a pollution degree 3 as defined by IEC/EN standard 60947-1.

#### Ambient temperature

hw+ circuit breakers can be used at temperatures between -25 °C and 70 °C.

For ambient temperatures greater than 50 °C, the devices must be derated.

See Chapter "hw+ circuit breakers and switch disconnectors" on page 21.

hw+ circuit breakers must be operated under normal ambient temperature conditions.

The permissible storage temperature range in the original packaging is from -25 °C to 85 °C.

### Electromagnetic interference

hw+ circuit breakers are protected against:

- Overvoltage caused by circuit switching, overvoltage caused by atmospheric disturbances or a breakdown in the distribution system.
- Devices emitting radio waves (walkie-talkies, radar, etc.).
- Electrostatic discharges produced directly by users.

The immunity levels comply with the following standards:

- IEC/EN 60947-2: Low-voltage switchgear and controlgear, Part 2: Circuit breakers.
- Appendix F 4.1: Current harmonic
- Appendix F 4.7: Current dips.
- Appendix B: Immunity tests for residual current protection
- IEC/EN 61000-4-2: Electrostatic discharge immunity tests.
- IEC/EN 61000-4-3: Radiated, radio-frequency, electromagnetic-field immunity tests
- IEC/EN 61000-4-4: Electrical fast transient/burst immunity tests.
- IEC/EN 61000-4-5: Surge immunity tests.
- IEC/EN 61000-4-6: Immunity tests for conducted disturbances induced by radio-frequency fields.
- CISPR 11: Limits and methods of measurement of electromagnetic disturbance characteristics of industrial, scientific and medical (ISM) radio-frequency equipment.

### Selectivity

Selectivity is a coordination technique between protection devices enabling the downstream device to trip on overcurrent without tripping the upstream device. This improves the service continuity. The hw+ devices have the characteristics necessary to implement this technique.

#### Total selectivity

Selectivity is said to be total if it is provided for all levels of short circuit up to the breaking capacity of the downstream device.

#### Partial selectivity

Selectivity is partial when the trip curves of the upstream device and downstream device overlap. Partial selectivity up to the point where the trip curves overlap, which is called the selectivity limit. The overlap zone of the curves indicates that there is no more selectivity and that it is very probably that the upstream circuit breaker and the downstream circuit breaker will trip simultaneously in case of fault.

The selectivity tables are provided in a separate document.



**Cascading**

The association enables protection devices to be used that have a breaking capacity lower than that of the presumed circuit current. The upstream device limits the short circuit current, preventing any damage to the downstream device.

The different values of short-circuit currents between different cascading of protection devices (ACB-MCCB-MCB) are given in coordination tables that are published in a separate document.

**Suitable for isolation with positive contact indication**

All hw+ circuit breakers are suitable for isolation as defined in standard IEC 60947-2:

- The isolation position corresponds to the O (OFF) position.

The isolation function is certified by tests guaranteeing:

- The mechanical reliability of the position indication system,
- The absence of leakage currents,
- The capacity to withstand overvoltage between upstream and downstream connections.

**Vibrations**

hw+ circuit breakers withstand mechanical vibrations.

hw+ circuit breakers comply with standard IEC 60068-2-6:

- 2.0 to 13.2 Hz and amplitude  $\pm 1$  mm.
- 13.2 to 100 Hz acceleration  $\pm 0.7$  g.
- Resonance frequency ( $\pm 1$  mm/ $\pm 0.7$  g for 90 min).

Excessive vibration may cause nuisance tripping and/or damage to connections and/or mechanical parts.

hw+ circuit breakers		HW1 size			
			HW1N... 42 kA	HW1M... 55 kA	HW1E... 66 kA
Reference					
Rated current at 50°C	(A)	HW1xx04... Compatible rating plug	400 400	400 400	400 400
		HW1xx06... Compatible rating plug	630 400 to 630	630 400 to 630	630 400 to 630
		HW1xx08... Compatible rating plug	800 400 to 800	800 400 to 800	800 400 to 800
		HW1xx10... Compatible rating plug	1000 400 to 1000	1000 400 to 1000	1000 400 to 1000
		HW1xx12... Compatible rating plug	1250 400 to 1250	1250 400 to 1250	1250 400 to 1250
		HW1xx16... Compatible rating plug	1600 400 to 1600	1600 400 to 1600	1600 400 to 1600
Selectivity category according to IEC 60947-2		-	B	B	B
Pollution degree according to IEC 60947-1		-	3	3	3
Rated ultimate short-circuit breaking capacity	(kA) Icu	380-415 V CA	42	55	66
		440 V AC	42	55	66
		500-525 V CA	42	42	42
		690 V AC	42	42	42
Rated operational short-circuit breaking capacity	(% Icu) Ics	-	100	100	100 <sup>(1)</sup>
Short-time withstand current rating capacity	(kA) Icw	1s - 400 V CA	42	55	55
		3s - 400 V CA	24	24	30
Rated breaking capacity	(kA peak) Icm	380-415 V CA	88	121	145
		440 V AC	88	121	145
		500-525 V CA	88	88	88
		690 V AC	88	88	88
Break time between tripping order and arc extinction	(ms)	-	< 25	< 25	< 25
Closing time	(ms)	-	< 50	< 50	< 50
Mechanical durability	(cycles x 1000)	With maintenance	12.5	12.5	12.5
Electrical endurance at In and 440 V	(cycles x 1000)	-	8	8	8
Electrical endurance at In and 690 V	(cycles x 1000)	-	6	6	6

(1) Ics: 55 kA for voltages 380 to 440 V

(2) Ics: 85 kA for voltages 380 to 440 V

(3) Ics: 100 kA for voltages 380 to 440 V

### hw+ circuit breakers common data

Rated operational voltage	Ue	(V AC - 50/60 Hz)	690
Rated insulation voltage	Ui	(V)	1,000
Rated impulse withstand voltage	Uimp	(kV)	12
Number of poles			3 / 4
Versions			Fixed / drawout
Standards compliance			IEC 60947-2

HW2 size				HW4 size			
	HW2M... 55 kA	HW2E... 66 kA	HW2S... 100 kA		HW4E... 66 kA	HW4S... 85 kA	HW2P... 120 kA
HW2xx06... Compatible rating plug	630 630	630 630	630 630	HW4xx10... Compatible rating plug	1000 1000	1000 1000	1000 1000
HW2xx08... Compatible rating plug	800 630 to 800	800 630 to 800	800 630 to 800	HW4xx12... Compatible rating plug	1250 1000 to 1250	1250 1000 to 1250	1250 1000 to 1250
HW2xx10... Compatible rating plug	1000 630 to 1000	1000 630 to 1000	1000 630 to 1000	HW4xx16... Compatible rating plug	1600 1000 to 1600	1600 1000 to 1600	1600 1000 to 1600
HW2xx12... Compatible rating plug	1200 630 to 1200	1200 630 to 1200	1200 630 to 1200	HW4xx20... Compatible rating plug	2000 1000 to 2000	2000 1000 to 2000	2000 1000 to 2000
HW2xx16... Compatible rating plug	1600 630 to 1600	1600 630 to 1600	1600 630 to 1600	HW4xx25... Compatible rating plug	2500 1000 to 2500	2500 1000 to 2500	2500 1000 to 2500
HW2xx20... Compatible rating plug	2000 630 to 2000	2000 630 to 2000	2000 630 to 2000	HW4xx32... Compatible rating plug	3200 1000 to 3200	3200 1000 to 3200	3200 1000 to 3200
HW2xx25... Compatible rating plug	2500 630 to 2500	2500 630 to 2500	2500 630 to 2500	HW4xx40... Compatible rating plug	4000 1000 to 4000	4000 1000 to 4000	4000 1000 to 4000
-	B	B	B	-	B	B	B
-	3	3	3	-	3	3	3
-	55	66	100	-	66	85	120
-	55	66	100	-	66	85	120
-	42	55	66	-	66	75	85
-	42	55	66	-	66	75	85
-	100	100	100 <sup>(2)</sup>	-	100	100	100 <sup>(3)</sup>
-	55	66	85	-	66	85	85
-	36	50	66	-	66	66	75
-	121	145	220	-	145	187	264
-	121	145	220	-	145	187	264
-	88	121	145	-	145	165	187
-	88	121	145	-	145	165	187
-	< 25	< 25	< 25	-	< 25	< 25	< 25
-	< 50	< 50	< 50	-	< 50	< 50	< 50
-	12.5	12.5	12.5	-	10	10	10
-	8	8	8	-	8	8	8
-	8	8	8	-	8	8	8

hw+ circuit breakers		HW6 size	
Reference			HW6L... 150 kA
Rated current at 50°C	(A)	HW6xx <b>63</b> ... Compatible rating plug	6300 3200 to 6300
Selectivity category according to IEC 60947-2		-	B
Pollution degree according to IEC 60947-1		-	3
Rated ultimate short-circuit breaking capacity	(kA) Icu	380-415 V CA	150
		440 V AC	150
		500-525 V CA	100
		690 V AC	100
Rated operational short-circuit breaking capacity	(% Icu) Ics	-	100 (4)
Short-time withstand current rating capacity	(kA) Icw	1s - 400 V CA	100
		3s - 400 V CA	75
Rated breaking capacity	(kA peak) Icm	380-415 V CA	330
		440 V AC	330
		500-525 V CA	220
		690 V AC	220
Break time between tripping order and arc extinction	(ms)	-	< 25
Closing time	(ms)	-	< 65
Mechanical durability	(cycles x 1000)	With maintenance	8.5
Electrical endurance at In and 440 V	(cycles x 1000)	-	6
Electrical endurance at In and 690 V	(cycles x 1000)	-	6

(1) Ics: 55 kA for voltages 380 to 440 V

(2) Ics: 85 kA for voltages 380 to 440 V

(3) Ics: 100 kA for voltages 380 to 440 V

(4) Ics: 150 kA for voltages 380 to 440 V

### hw+ circuit breakers common data

Rated operational voltage	Ue	(V AC - 50/60 Hz)	690
Rated insulation voltage	Ui	(V)	1,000
Rated impulse withstand voltage	Uimp	(kV)	12
Number of poles			3 / 4
Versions			Fixed / drawout
Standards compliance			IEC 60947-2

hw+ circuit breakers		HW1 size		HW2 size		HW4 size	
		3 poles	4 poles	3 poles	4 poles	3 poles	4 poles
<b>Weight (kg)</b>							
Fixed version (without accessories)		14	18	40	49	51	65
Drawout version without chassis (without accessories)		15	19	38	49	51	65
Chassis alone (without accessories)		13	15	38	44	48	59
<b>Dimensions (max. value in mm)</b>							
Width a	fixed version	276	346	385	480	478	604
	drawout version	284	349	400	495	493	619
Height b	fixed version	313	313	416	416	416	416
	drawout version	322	322	450	450	450	450
Depth c with connections	fixed version	227	227	373	373	373	373
	drawout version	328	328	465	465	465	465
Depth of connections		49	49	82	82	82	82

**Fixed version**

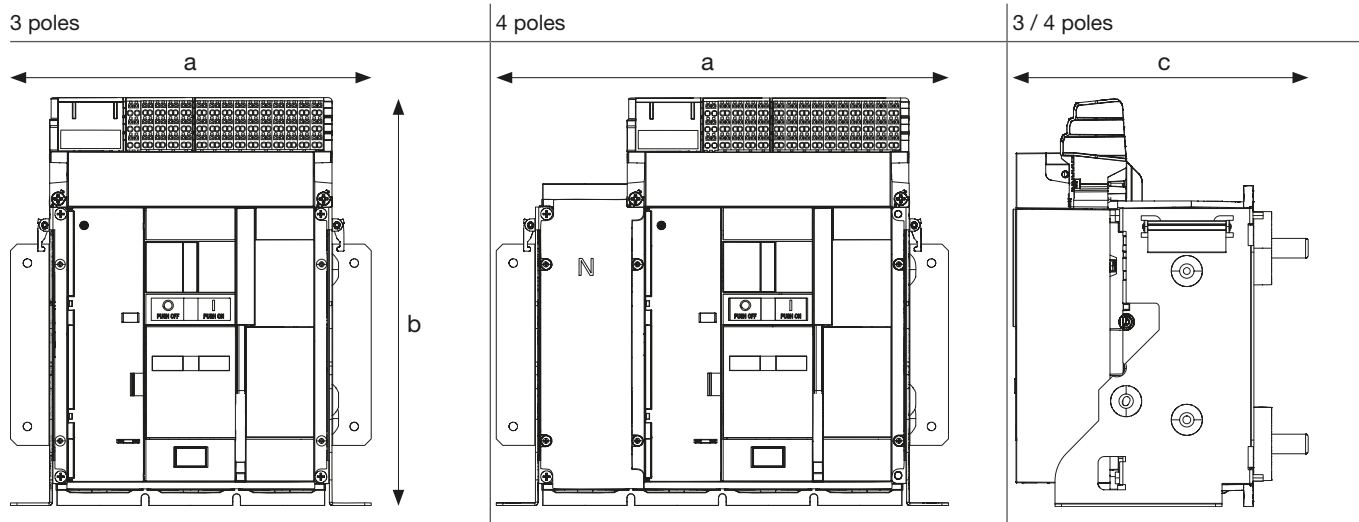

**Drawout version**

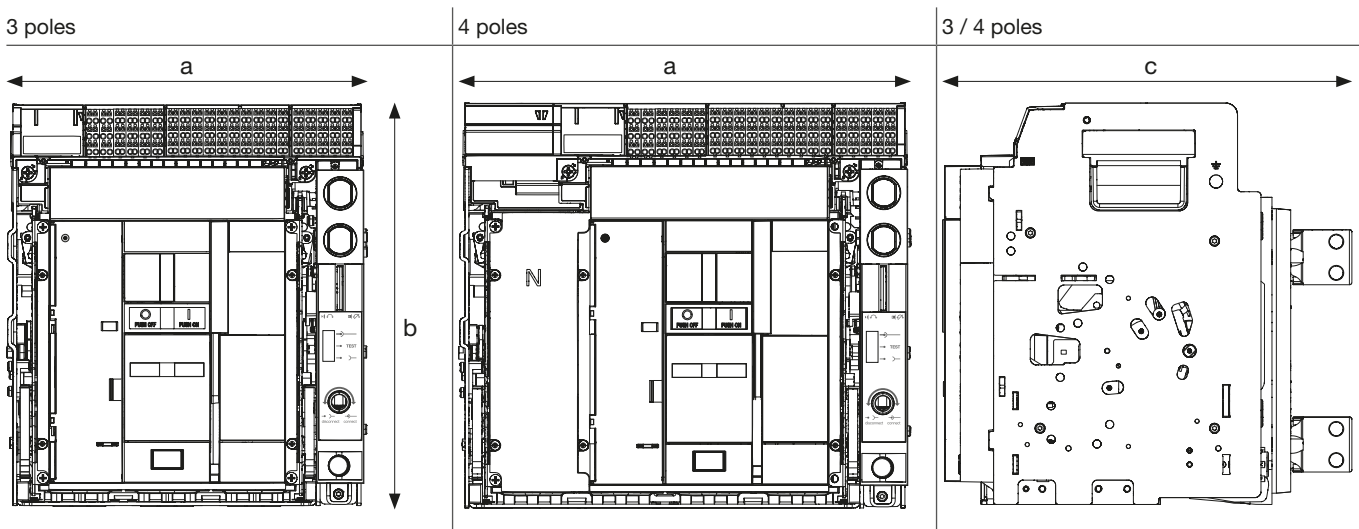

hw+ circuit breakers		HW6 size	
		3 poles	4 poles
<b>Weight (kg)</b>			
Drawout version without chassis (without accessories)		141	176
Chassis alone (without accessories)		92	116
<b>Dimensions (max. value in mm)</b>		<b>3 poles</b>	<b>4 poles</b>
Width a	drawout version	871	1123
Height b	drawout version	490	490
Depth c with connections	drawout version	514	514
Depth of connections		131	131

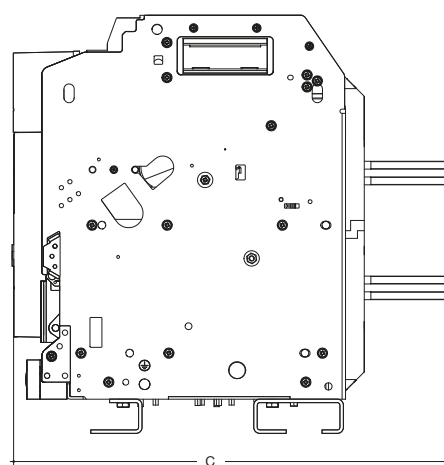
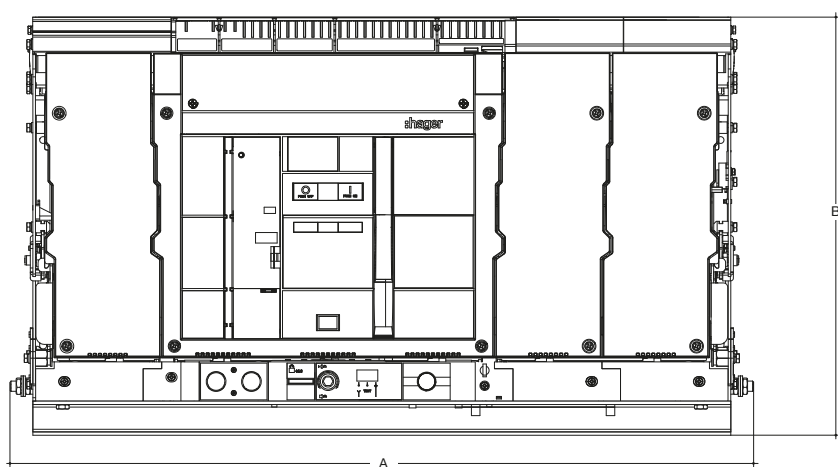

### Switch-disconnector protection

The hw+ switch-disconnector is adapted to switching loads as per AC-22A and AC-23A. It guarantees the disconnection of the circuit which can be secured by the locking accessories available in the hw+ range.

Protection against overload and short circuit must be provided by a circuit breaker upstream of the switch-disconnector and in compliance with installation standards.

In the fixed version, disconnection is fully visible by means of the status indicator.

In the drawout version, it is considered to be a visible disconnection when the product is withdrawn. This ensures optimal protection for users when working on the installation.

hw+ switch-disconnectors		HW1 size		HW2 size		HW4 size	
Reference			HW1W...		HW2W...		HW4W...
Rated current at 50°C (A)		HW1Wx04...	400	HW2Wx06...	630	HW4Wx10...	1000
		HW1Wx06...	630	HW2Wx08...	800	HW4Wx12...	1250
		HW1Wx08...	800	HW2Wx10...	1000	HW4Wx16...	1600
		HW1Wx10...	1000	HW2Wx12...	1250	HW4Wx20...	2000
		HW1Wx12...	1250	HW2Wx16...	1600	HW4Wx25...	2500
		HW1Wx16...	1600	HW2Wx20...	2000	HW4Wx32...	3200
				HW2Wx25...	2500	HW4Wx40...	4000
Utilization category according to IEC 60947-3	-	AC-23A	-	AC-23A	-	AC-23A	
Pollution degree according to IEC 60947-1	-	3	-	3	-	3	
Short-time withstand current rating capacity (kA) I <sub>cw</sub>	1s - 400 V CA	55	-	66	-	85	
Rated short-circuit making capacity (kA peak) I <sub>cm</sub>	380-415 V CA	121	-	145	-	187	
	440 V AC	121		145	-	187	
	500-525 V CA	88	-	145	-	187	
	690 V AC	88	-	145	-	187	
Mechanical durability (cycles x 1000)	With maintenance	12.5	-	12.5	-	10	
Electrical endurance at I <sub>n</sub> (cycles x 1000)	-	6	-	10 (for I <sub>n</sub> ≤ 1600A) 8 (for I <sub>n</sub> ≥ 2000A)	-	6	

### hw+ switch-disconnector common data

Rated operational voltage	U <sub>e</sub>	(V AC - 50/60 Hz)	690
Rated insulation voltage	U <sub>i</sub>	(V)	1,000
Rated impulse withstand voltage	U <sub>imp</sub>	(kV)	12
Number of poles			3 / 4
Versions			Fixed / drawout
Standards compliance			IEC 60947-3

hw+ switch-disconnectors		HW6 size	
Reference		HW6W...	
Rated current at 50°C (A)		HW6Wx63...	6300
Utilization category according to IEC 60947-3		-	AC-23A
Pollution degree according to IEC 60947-1		-	3
Short-time withstand current rating capacity (kA) I <sub>cw</sub>		1s - 400 V CA	100
Rated short-circuit making capacity (kA peak) I <sub>cm</sub>		380-415 V CA	330
		440 V AC	330
		500-525 V CA	220
		690 V AC	220
Mechanical durability (cycles x 1000)		With maintenance	8.5
Electrical endurance at I <sub>n</sub> (cycles x 1000)		-	6

### hw+ switch-disconnector common data

Rated operational voltage	U <sub>e</sub>	(V AC - 50/60 Hz)	690
Rated insulation voltage	U <sub>i</sub>	(V)	1,000
Rated impulse withstand voltage	U <sub>imp</sub>	(kV)	12
Number of poles			3 / 4
Versions			Fixed / drawout
Standards compliance			IEC 60947-3



hw+ switch-disconnectors		HW1 size		HW2 size		HW4 size	
		3 poles	4 poles	3 poles	4 poles	3 poles	4 poles
<b>Weight (kg)</b>							
Fixed version (without accessories)		14	18	39	48	48	62
Drawout version without chassis (without accessories)		15	19	37	47	48	62
Chassis alone (without accessories)		13	15	38	44	49	59
<b>Dimensions (max. value in mm)</b>							
Width a	fixed version	276	346	368	463	461	587
	drawout version	284	349	347	442	440	566
Height b	fixed version	313	313	416	416	416	416
	drawout version	322	322	450	450	450	450
Depth c with connections	fixed version	227	227	373	373	373	373
	drawout version	328	328	465	465	465	465
Depth of connections		49	49	72	72	72	72

**Fixed version**

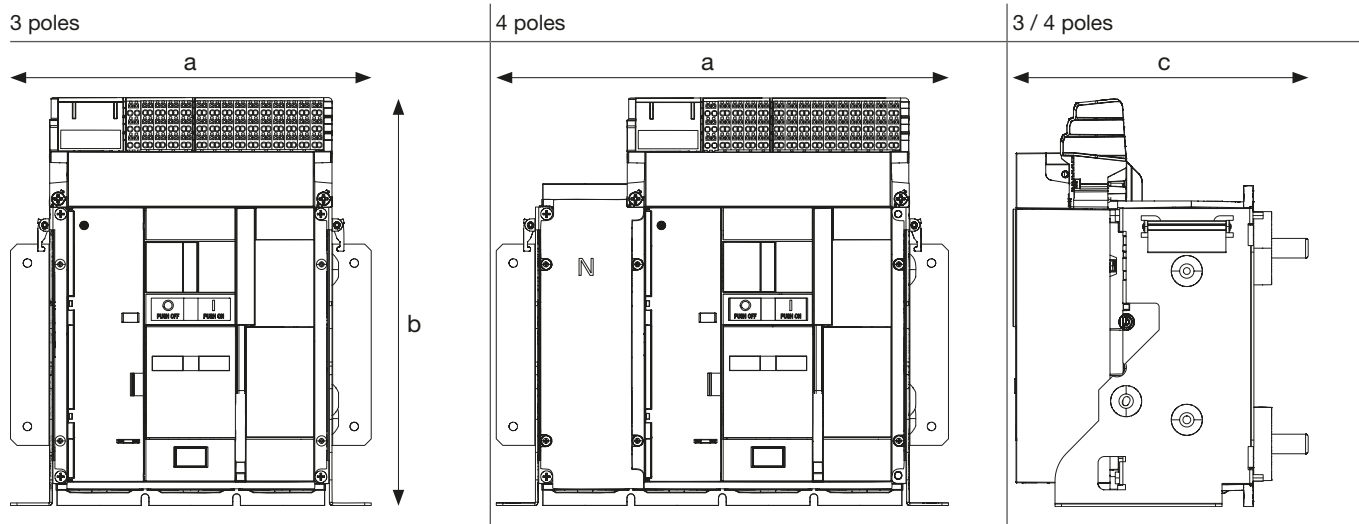

**Drawout version**

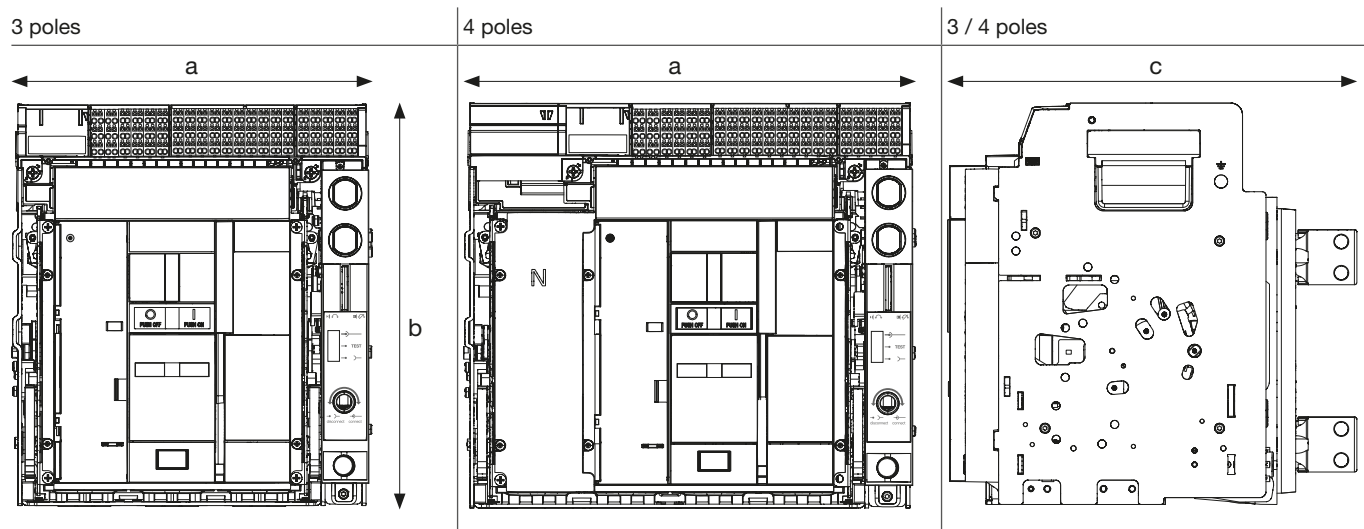

hw+ switch-disconnectors		HW6 size	
		3 poles	4 poles
<b>Weight (kg)</b>			
Drawout version without chassis (without accessories)		141	176
Chassis alone (without accessories)		92	116
<b>Dimensions (max. value in mm)</b>		<b>3 poles</b>	<b>4 poles</b>
Width a	drawout version	871	1123
Height b	drawout version	490	490
Depth c with connections	drawout version	514	514
Depth of connections		131	131

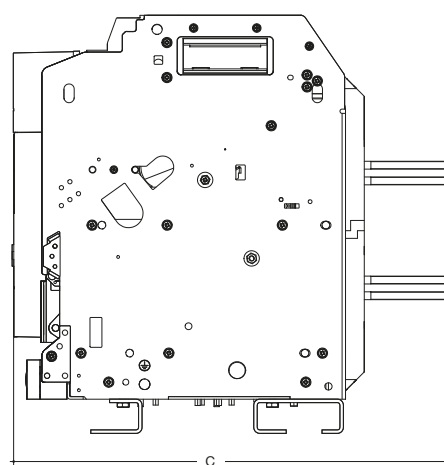
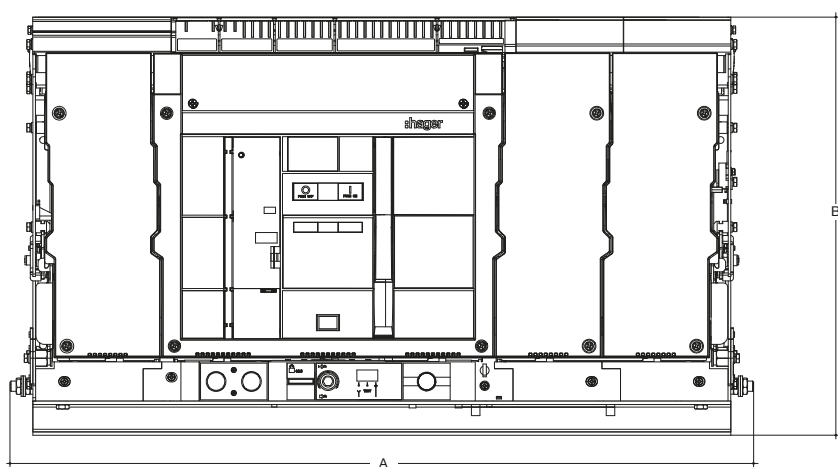

# sentinel electronic trip units

Page

<b>01 General description</b>	<b>46</b>
<b>02 LI trip unit</b>	<b>48</b>
<b>03 LSI trip unit</b>	<b>50</b>
<b>04 LSIG trip unit</b>	<b>52</b>

hw+ air circuit breakers are equipped with a sentinel electronic trip unit to protect against overloads, short circuits and earth faults. The circuit breaker has a display and dials enabling the user to configure the protection settings and monitor its correct operation.

The following characteristics are common to all versions of the sentinel electronic trip units:

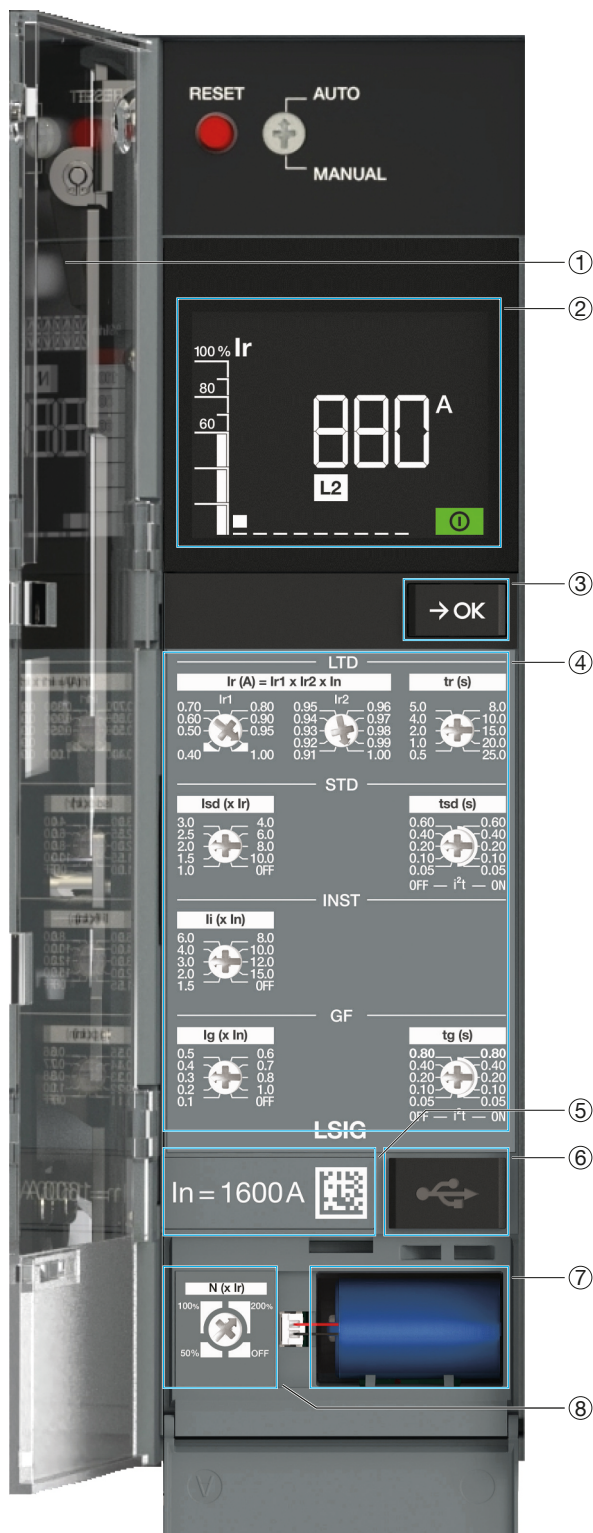

- ① Transparent cover protecting access to the sentinel electronic trip unit settings (sealable).
- ② LCD display.
- ③ Button **→OK** which can be used:
  - to acknowledge and clear an alarm after a trip,
  - to navigate through the different screens of the display.
- ④ Settings dials of the sentinel electronic trip unit.
- ⑤ Rated current value  $I_n$  of the air circuit breaker. This value is limited by the rating plug fitted on the electronic trip unit.
- ⑥ USB-C port to connect an external battery. This USB-C port is also used to connect to computers equipped with the Hager Power setup commissioning and test software.
- ⑦ Backup battery compartment. The backup battery powers the display after electrical tripping. This enables the display to signal the tripping and its cause. This icon  lights up on the display when the battery needs to be replaced.
- ⑧ Neutral protection settings dial.

### ATTENTION

The electronic trip unit must be powered in order for it to perform its protection functions. It is powered as long as a minimum current of 20% of the nominal current  $I_n$  passes through the circuit breaker. Nevertheless, it is strongly recommended that a 24V DC SELV external power supply be connected (recommended product reference Hager HTG911H) on the TU terminal to guarantee optimal operation of the trip unit and prevent malfunctions in the electrical installation associated with a breach in the trip unit's continuity of operation.

**Description of the LCD display**

sentinel electronic trip units are equipped with an LCD display that makes it easy to adjust the settings and read the cause of the tripping of hw+ circuit breakers.

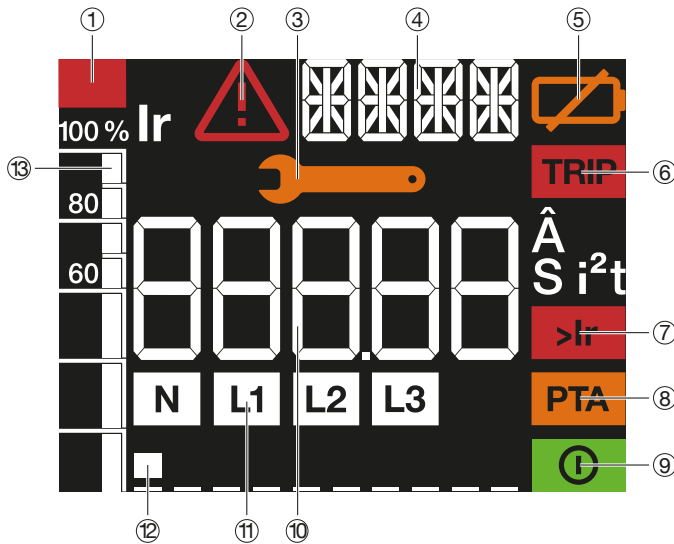

- ① **Overload indicator:** shows when the current exceeds 105% of Ir.
- ② **Error indicator:** displays when an error is detected.
- ③ **Maintenance indicator:** displays when a maintenance intervention is required.
- ④ **Text display area:** displays the name of the protection parameter during setting or after a trip as well as the error codes of detected operating system alarms.
- ⑤ **Battery weak or absent indicator:** displays when it is necessary to change the back-up battery of the electronic trip unit or when it is not connected.
- ⑥ **Trip indicator:** allows the cause of the tripping to be identified precisely using the numerical display area, the text display area and the phase display.
- ⑦ **Overload indicator:** flashes when the current exceeds 105 % of Ir and is constant when above 112.5 % of Ir.
- ⑧ **Overload pre-alarm indicator:** provides an alert when there is an imminent risk of tripping.
- ⑨ **ReadyToProtect indicator:** displays when the trip unit is operational and ready to protect.
- ⑩ **Numerical display area:** allows the values of the different settings to be displayed directly and also indicates what the trip value was for the following units.
 

A	Ampere
Â	Peak current
S	Second
I²t	I²t curve

Also displays the codes of the critical system alarms.
- ⑪ **Phase display:** Neutral on the left / Phase L1 / Phase L2 / Phase L3.
- ⑫ **Marker screen:** shows the number of screens in the trip unit as well as its position in the display order.
- ⑬ **Bar graph:** displays the currents read on the most heavily loaded phase L1, L2 and L3 as a percentage of the setting Ir.

sentinel electronic trip units

There are 3 versions of the sentinel electronic trip unit: **LI**, **LSI** and **LSIG**

### LI sentinel trip unit

The LI sentinel trip unit is used to protect long cable lines where the rated fault current is limited due to the impedance of the cable.

The dials are accessible from the front of the electronic trip unit, allowing precise adjustment of the protection settings. The protection adjusted in this way is independent of the ambient temperature.

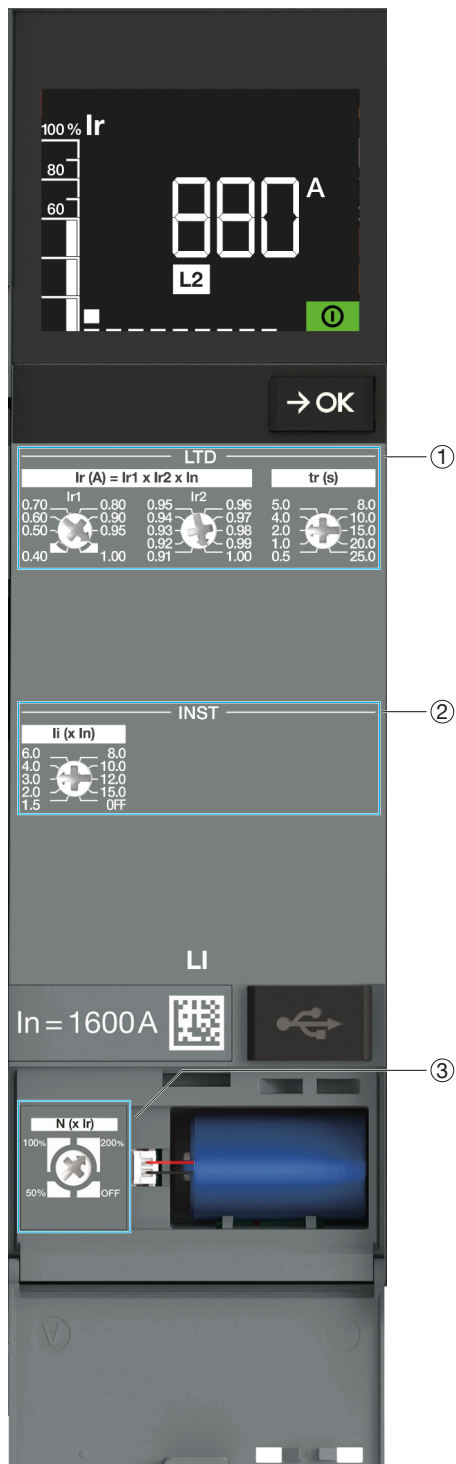

- ① **LTD Long Time Delay protection**  
The long time delay curve offers overload protection. Fine setting of Ir (A) is done using two dials Ir1 and Ir2. The time delay tr (s) can be set using a dial from 0.5 to 25 s.
- ② **INST Instantaneous protection**  
The Instantaneous protection against short-circuits li (x In) can be set using a dial from 1.5 to 15 times the rated current value In. This protection can also be deactivated (OFF).
- ③ **Neutral protection N**  
This protection is factory-installed on 4-pole circuit breakers and as an option with the addition of the ENCT external neutral sensor on 3-pole versions. It is necessary if the neutral conductor cross section is less than that of the phases, or if the neutral conductor is heavily loaded (for example, in office buildings). It uses similar tripping curve characteristics as the Long time delay, Short time delay and instantaneous protection parameters.

LI sentinel trip unit

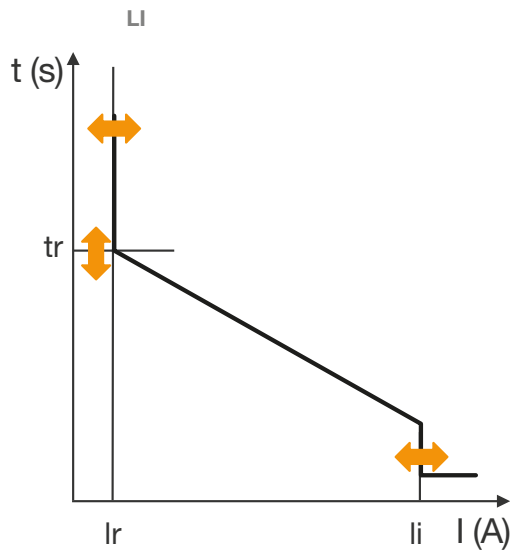

Rated current In

In at 50 °C	400 A	630 A	800 A	1000 A	1250 A	1600 A	2000 A	2500 A	3200 A	4000 A	5000 A	6300 A
-------------	-------	-------	-------	--------	--------	--------	--------	--------	--------	--------	--------	--------

Long Time Delay protection L (ANSI 49)

Ir (tripping threshold between 1.05 and 1.20 x Ir)	
Ir1	0.40 - 0.50 - 0.60 - 0.70 - 0.80 - 0.90 - 0.95 - 1.00
Ir2	0.91 - 0.92 - 0.93 - 0.94 - 0.95 - 0.96 - 0.97 - 0.98 - 0.99 - 1.00
Ir (A) = Ir1 x Ir2 x In	0.364 x In ... 1 x In
In = 400 A	145.6 - 400 A
In = 630 A	229.3 - 630 A
In = 800 A	291.2 - 800 A
In = 1000 A	364 - 1000 A
In = 1250 A	455 - 1250 A
In = 1600 A	582.4 - 1600 A
In = 2000 A	728 - 2000 A
In = 2500 A	910 - 2500 A
In = 3200 A	1164.8 - 3200 A
In = 4000 A	1456 - 4000 A
In = 5000 A	1820 - 5000 A
In = 6300 A	2300 - 6300 A
Time delay (s)	
tr	0.5 - 1.0 - 2.0 - 4.0 - 5.0 - 8.0 - 10.0 - 15.0 - 20.0 - 25.0
accuracy	0 % to -20 %

Instantaneous Protection INST (ANSI 50)

li = In x ...	OFF - 1.5 - 2.0 - 3.0 - 4.0 - 6.0 - 8.0 - 10.0 - 12.0 - 15.0
accuracy	+/- 15 %
Tripping time (ms)	> 20
Maximum breaking time (ms)	≤ 80

Neutral protection N

Neutral protection = Phase protection Ir x ...	OFF - 50 % - 100 % - 200 %
Instantaneous protection	same as phases
Time delay	same as phases for tr and instantaneous

### LSI sentinel trip unit

The LSI sentinel trip unit is used to protect cable lines and equipment requiring a wide variety of protection settings. The settings dials are accessible from the front of the hw+ circuit breakers, allowing precise adjustment of the protection settings. The protection adjusted in this way is independent of the ambient temperature.

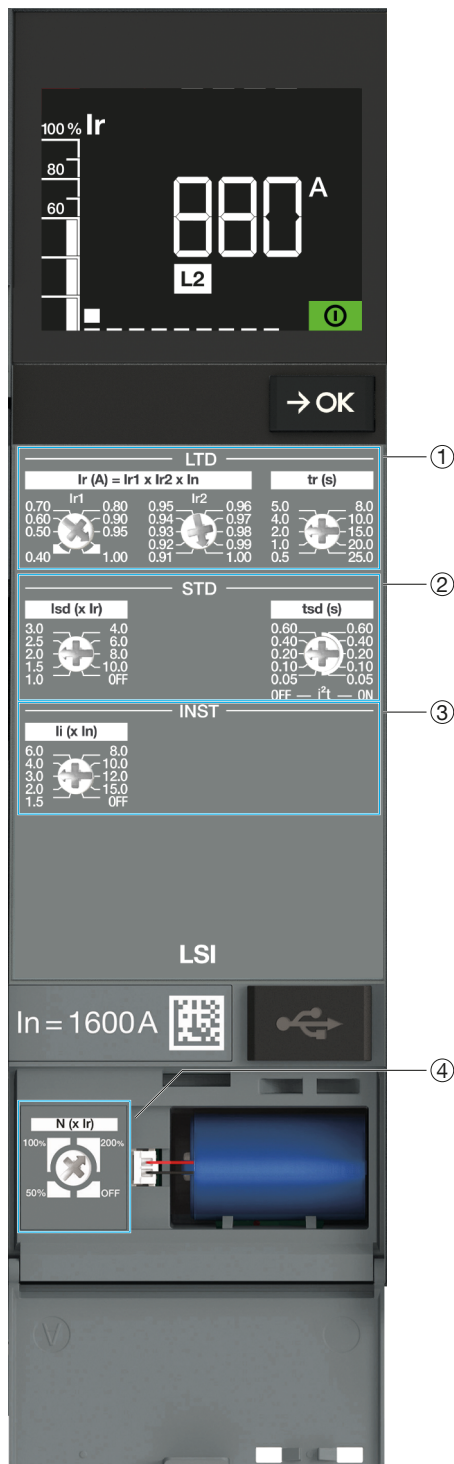

- ① **LTD Long Time Delay protection**  
The long time delay curve offers overload protection. Fine setting of  $I_r$  (A) is done using two dials  $I_{r1}$  and  $I_{r2}$ . The time delay  $t_r$  (s) can be set using a dial from 0.5 to 25 s.
- ② **STD Short Time Delay Protection**  
Short Time Delay protection is for short-circuits. The  $I_{sd}$  (x  $I_r$ ) current can be adjusted using a dial from 1 to 10 times the protection of the  $I_r$  Long Time Delay protection of the circuit breaker. This protection can also be deactivated (OFF). Time delay  $t_{sd}$  (s) is adjustable via a dial from 50 to 600 ms with the possibility of including an inverse time curve ( $I^2t$  OFF or ON).
- ③ **INST Instantaneous protection**  
The Instantaneous protection against short-circuits  $I_i$  (x  $I_n$ ) can be set using a dial from 1.5 to 15 times the rated current value  $I_n$ . This protection can also be deactivated (OFF).
- ④ **Neutral protection N**  
Neutral protection is factory-installed on 4-pole circuit breakers and as an option with the addition of the ENCT external neutral sensor on 3-pole versions. It is necessary if the neutral conductor cross section is less than that of the phases, or if the neutral conductor is heavily loaded (for example, in office buildings). It uses the long time delay, short time delay and instantaneous protection settings.

### Zone Selective Interlocking (ZSI)

Zone Selectivity (ZSI) is available on LSI sentinel trip units. It can be used for short time delay protection (ZSI STD). The function is activated using the Hager Power setup software.



## LSI sentinel trip unit

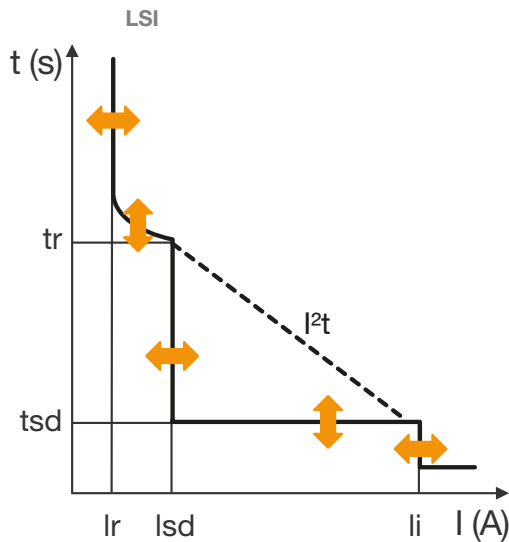

### Rated current $I_n$

$I_n$ at 50 °C	400 A	630 A	800 A	1000 A	1250 A	1600 A	2000 A	2500 A	3200 A	4000 A	5000 A	6300 A
----------------	-------	-------	-------	--------	--------	--------	--------	--------	--------	--------	--------	--------

### Long Time Delay protection L (ANSI 49)

$I_r$ (tripping threshold between 1.05 and 1.20 x $I_r$ )	
$I_{r1}$	0.40 - 0.50 - 0.60 - 0.70 - 0.80 - 0.90 - 0.95 - 1.00
$I_{r2}$	0.91 - 0.92 - 0.93 - 0.94 - 0.95 - 0.96 - 0.97 - 0.98 - 0.99 - 1.00
$I_r$ (A) = $I_{r1} \times I_{r2} \times I_n$	0.364 x $I_n$ ... 1 x $I_n$
$I_n = 400A$	145.6 - 400A
$I_n = 630A$	229.3 - 630A
$I_n = 800A$	291.2 - 800A
$I_n = 1000A$	364 - 1000A
$I_n = 1250A$	455 - 1250A
$I_n = 1600A$	582.4 - 1600A
$I_n = 2000A$	728 - 2000A
$I_n = 2500A$	910 - 2500A
$I_n = 3200A$	1164.8 - 3200A
$I_n = 4000A$	1456 - 4000A
$I_n = 5000A$	1820 - 5000A
$I_n = 6300A$	2300 - 6300A
Time delay (s)	$t_r$ 0.5 - 1.0 - 2.0 - 4.0 - 5.0 - 8.0 - 10.0 - 15.0 - 20.0 - 25.0
	accuracy 0 % to -20 %

### Short Time Delay protection STD (ANSI 50TD/51)

$I_{sd} = I_r \times \dots$	OFF - 1.0 - 1.5 - 2.0 - 2.5 - 3.0 - 4.0 - 6.0 - 8.0 - 10.0
	accuracy +/- 10 %
Time delay (s)	$t_{sd} I^2 t$ OFF 0.05 0.10 0.20 0.40 0.60
	$t_{sd} I^2 t$ ON 0.05 0.10 0.20 0.40 0.60
Tripping time (ms)	0.025 0.075 0.175 0.375 0.575
Maximum breaking time (ms)	0.12 0.17 0.27 0.47 0.67

### Instantaneous Protection INST (ANSI 50)

$I_i = I_n \times \dots$	OFF - 1.5 - 2.0 - 3.0 - 4.0 - 6.0 - 8.0 - 10.0 - 12.0 - 15.0
	accuracy +/- 15 %
Tripping time (ms)	> 20
Maximum breaking time (ms)	≤ 80

### Neutral protection N

Neutral protection = Phase protection $I_r \times \dots$	OFF - 50 % - 100 % - 200 %
phase protection $I_{sd} \times \dots$	
Instantaneous protection	same as phases
Time delay	same as phases for $t_r$ and instantaneous

### LSIG sentinel trip unit

The LSIG sentinel trip unit is used to protect cable lines and equipment for scenarios with a TN earthing system where earth fault protection is required.

The settings dials are accessible from the front of the hw+ circuit breakers, allowing precise adjustment of the protection settings. The protection adjusted in this way is independent of the ambient temperature.

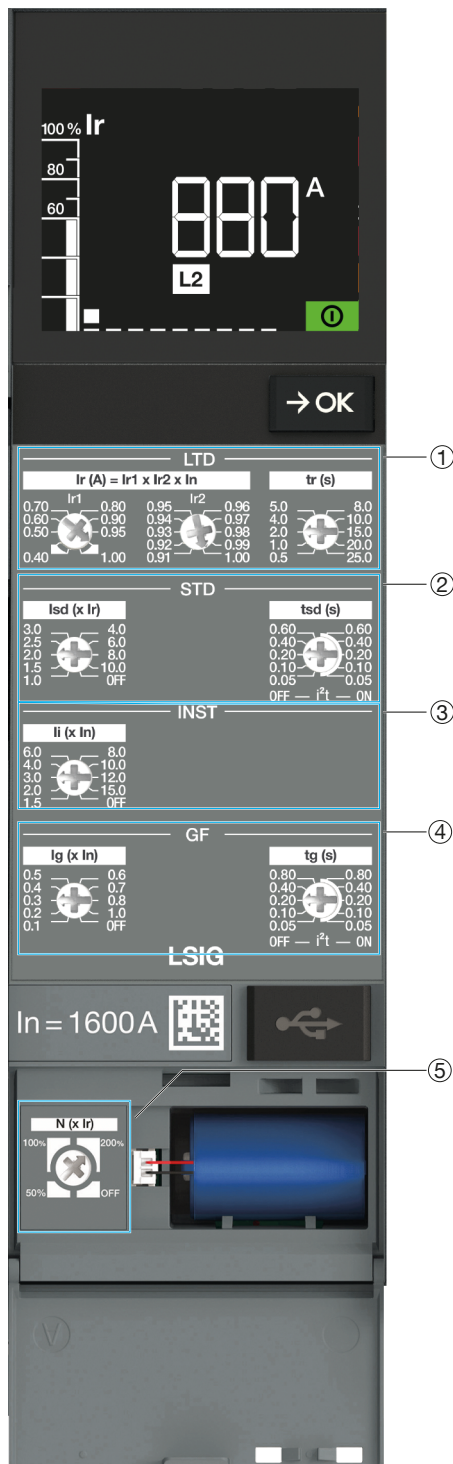

- ① **LTD Long Time Delay protection**  
The long time delay curve offers overload protection. Fine setting of  $I_r$  (A) is done using two dials  $I_{r1}$  and  $I_{r2}$ . The time delay  $t_r$ (s) can be set via a dial from 0.5 to 25 s.
- ② **STD Short Time Delay Protection**  
Short Time Delay protection is for short-circuits. The  $I_{sd}$  (x  $I_r$ ) current can be adjusted using a dial from 1 to 10 times the protection of the  $I_r$  Long Time Delay protection of the circuit breaker. This protection can also be deactivated (OFF). Time delay  $t_{sd}$  (s) is adjustable via a dial from 50 to 600 ms with the possibility of including an inverse time curve ( $I^2t$  OFF or ON).
- ③ **INST Instantaneous protection**  
The instantaneous protection against short-circuits  $I_i$  (x  $I_n$ ) can be set using a dial from 1.5 to 15 times the rated current value  $I_n$ . This protection can also be deactivated (OFF).
- ④ **GF earth fault protection**  
The earth protection is used against phase-to-earth faults. The earth fault currents can reach a high enough amplitude that they are similar to a short circuit. It is based on the calculation of the vector sum of the phases and the neutral current. The current  $I_g$  (x  $I_n$ ) can be set using a dial from 0.1 to 1 times the rated current  $I_n$ . The earth fault protection can also be disabled (OFF). The time delay  $t_g$  (s) is adjustable via a dial from 50 to 600 ms with the possibility of including an inverse time curve ( $I^2t$  OFF or ON).
- ⑤ **Neutral protection N**  
Neutral protection is factory-installed on 4-pole circuit breakers and as an option with the addition of the ENCT external neutral sensor on 3-pole versions. It is necessary if the neutral conductor cross section is less than that of the phases, or if the neutral conductor is heavily loaded (for example, in office buildings). It uses similar tripping curve characteristics as the Long time delay, Short time delay and instantaneous protection parameters.

### Zone Selective Interlocking (ZSI)

Zone Selectivity (ZSI) is available on LSIG sentinel trip units. It can be used for the Short Time Delay protection (ZSI STD) and the earth Fault protection (ZSI GF). The function is activated using the Hager Power setup software.

## LSI sentinel trip unit

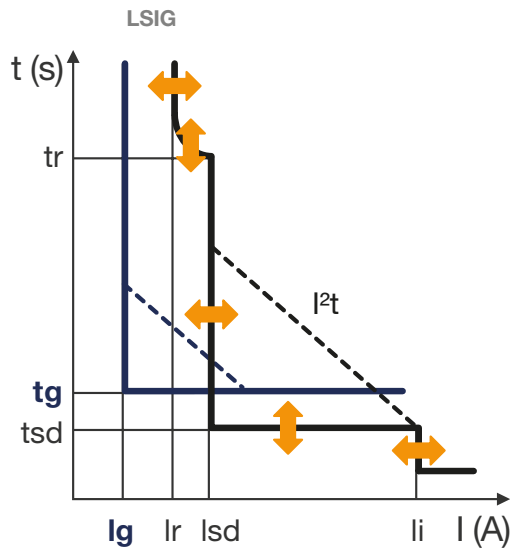

### Rated current $I_n$

$I_n$ at 50°C	400 A	630 A	800 A	1000 A	1250 A	1600 A	2000 A	2500 A	3200 A	4000 A	5000 A	6300 A
---------------	-------	-------	-------	--------	--------	--------	--------	--------	--------	--------	--------	--------

### Long Time Delay protection L (ANSI 49)

$I_r$ (tripping threshold between 1.05 and 1.20 x $I_r$ )	
$I_{r1}$	0.40 - 0.50 - 0.60 - 0.70 - 0.80 - 0.90 - 0.95 - 1.00
$I_{r2}$	0.91 - 0.92 - 0.93 - 0.94 - 0.95 - 0.96 - 0.97 - 0.98 - 0.99 - 1.00
$I_r$ (A) = $I_{r1} \times I_{r2} \times I_n$	0.364 x $I_n$ ... 1 x $I_n$
$I_n = 400$ A	145.6 - 400 A
$I_n = 630$ A	229.3 - 630 A
$I_n = 800$ A	291.2 - 800 A
$I_n = 1000$ A	364 - 1000 A
$I_n = 1250$ A	455 - 1250 A
$I_n = 1600$ A	582.4 - 1600 A
$I_n = 2000$ A	728 - 2000 A
$I_n = 2500$ A	910 - 2500 A
$I_n = 3200$ A	1164.8 - 3200 A
$I_n = 4000$ A	1456 - 4000 A
$I_n = 5000$ A	1820 - 5000 A
$I_n = 6300$ A	2300 - 6300 A
Time delay (s)	
$t_r$	0.5 - 1.0 - 2.0 - 4.0 - 5.0 - 8.0 - 10.0 - 15.0 - 20.0 - 25.0
accuracy	0 % to -20 %

### Short Time Delay protection STD (ANSI 50TD/51)

$I_{sd} = I_r \times \dots$		OFF - 1.0 - 1.5 - 2.0 - 2.5 - 3.0 - 4.0 - 6.0 - 8.0 - 10.0
accuracy		+/- 10 %
Time delay (s)	$t_{sd} I^2t$ OFF	0.05   0.10   0.20   0.40   0.60
	$t_{sd} I^2t$ ON	0.05   0.10   0.20   0.40   0.60
Non-tripping time (s)		0.025   0.075   0.175   0.375   0.575
Maximum tripping time (s)		0.1   0.15   0.25   0.45   0.65
Maximum breaking time (s)		0.12   0.17   0.27   0.47   0.67

### Instantaneous Protection INST (ANSI 50)

$I_i = I_n \times \dots$		OFF - 1.5 - 2.0 - 3.0 - 4.0 - 6.0 - 8.0 - 10.0 - 12.0 - 15.0
accuracy		+/- 15 %
Tripping time (ms)		> 20
Maximum breaking time (ms)		≤ 80

**GF earth fault tripping (ANSI 50N TD/51N)**

I <sub>g</sub> = I <sub>n</sub> x ...	OFF - 0.1 - 0.2 - 0.3 - 0.3 - 0.4 - 0.5 - 0.6 - 0.7 - 0.8 - 0.9 - 1.0					
Time delay (s)	tg I <sup>2</sup> t OFF	0.05	0.10	0.20	0.40	0.80
	tg I <sup>2</sup> t ON	0.05	0.10	0.20	0.40	0.80
Non-tripping time (s)		0.025	0.075	0.175	0.375	0.775
Maximum tripping time (s)		0.1	0.15	0.25	0.45	0.85
Maximum breaking time (s)		0.12	0.17	0.27	0.47	0.87

**Neutral protection N**

Neutral protection = Phase protection I <sub>r</sub> x ... phase protection I <sub>sd</sub> x ...	OFF - 50 % - 100 % - 200 %
Instantaneous protection	same as phases
Time delay	same as phases for tr and instantaneous

# sentinel Energy electronic trip units

Page

01 General description	56
02 LSI trip unit	64
03 LSIg trip unit	66
04 Measurement function	68
05 Advanced protections	73

The sentinel Energy electronic trip unit provides protection, alarm, measurement, communication and remote control functions.

In addition to the standard functions, offers optional functions for advance use tailored to the needs of the electrical installation.

The availability of the optional functions depends on the type of rating plug installed.

The standard functions are indicated in the following table.

<b>Standard functions</b>	<b>Energy LSI</b>	<b>Energy LSIG</b>
Long Time Delay protection against overcurrent (L)	■	■
Long Time Delay protection against overcurrent IEC 60255-151	■	■
Short Time Delay protection against overcurrent (S)	■	■
Instantaneous protection against overcurrent (I)	■	■
Earth fault protection (G)	-	■
Neutral protection	■	■
Dual settings (profile A - profile B)	■	■
Zone Selective Interlocking (ZSI)	■	■
Trip and overload alarms	■	■
Optional alarms	■	■
Protection against electronic malfunctions (HWF)	■	■
Trip Test	■	■
Trip history	■	■
History of status and parameter changes	■	■
Class 1 embedded energy meter	■	■
Measurement of current, voltage and power	■	■
Measurement of frequency, phase sequence and power factors	■	■
Maintenance alarm	■	■

The optional functions are indicated in the following table.

<b>Optional functions</b>	<b>Meter Plus</b>	<b>Harmonic</b>	<b>Advanced</b>	<b>Ultimate</b>
Measurement of total harmonic distortion THDV and THDV	■	■	■	■
Analysis of individual harmonics	-	■	-	■
Measurement of voltage unbalances	-	■	■	■
Alarm for voltage dips and swells	-	■	■	■
Multi-tariff energy meters	■	■	-	■
Undervoltage protection - ANSI 27	-	-	■	■
Overvoltage protection - ANSI 59	-	-	■	■
Underfrequency protection - ANSI 81L	-	-	■	■
Overfrequency protection - ANSI 81H	-	-	■	■
Reverse active power protection - ANSI 32R	-	-	■	■
Phase unbalance protection - ANSI 46	-	-	■	■
Voltage unbalance protection - ANSI 47	-	-	■	■

The sentinel Energy trip unit accepts the same compatible standard rating plug reference models as the sentinel trip unit.



### Standard rating plug

If a standard rating plug is fitted, only the standard functions will be installed on the sentinel Energy trip unit.



### Optional rating plug

The sentinel Energy trip unit also accepts optional rating plugs recognizable by their colour.

If an optional rating plug is fitted, only the standard functions and group of related optional functions Meter Plus, Harmonic, Advanced or Ultimate will be installed on the sentinel Energy trip unit.

The optional rating plugs are not compatible with the sentinel trip unit.

### Long Time Delay protection against overcurrent IEC 60255-151

In addition to the usual L, S, I and G protections, the sentinel Energy trip unit allows the Long time delay protection to be configured in accordance with the requirements of the IEC 60255-151 in order to adapt the protection of the conductors, the busbars and the busbar trunkings against overcurrents when selectivity needs to be improved with an upstream protection device.

### Dual settings (profile A - profile B)

Dual settings allow two protection setting profiles A and B to be defined so that the trip unit can switch operating between protection profile A and protection profile B if a single circuit breaker is intended to protect 2 sources of a changeover switch.

### Zone Selective Interlocking (ZSI)

Zone Selectivity (ZSI) is available on sentinel and sentinel Energy trip units. It can be used for the Short Time Delay protection (ZSI STD) and the earth Fault protection (ZSI GF).

### Optional alarms

The sentinel Energy trip unit enables programming of up to twelve optional alarms to audit an event of measurement by defining thresholds and activation time delays and deactivation of these alarms.

The same measurement can be used for different custom alarms to precisely monitor certain values, e.g. the frequency or the voltage.

### Communication

The sentinel Energy trip unit allows Bluetooth Low Energy communication with the Hager Power touch application.

It allows a Modbus-RTU or Modbus-TCP communication module to be added.

The HTD210H panel display

is compatible with the sentinel Energy trip unit.

### Measurement with the sentinel Energy trip unit

The sentinel Energy trip unit includes as standard all functions of a measurement device classified PMD-II in accordance with IEC 61557-12 Version 2, with in particular a class 1 measurement accuracy of active powers and energies. This includes all measurements of current, voltage, frequency, power and energies.

As an option, the measurement of harmonic distortion rates in voltage and current allows equivalence to a PMD-III type measurement device to be achieved.

As an option, the sentinel Energy trip unit enables measurement of the individual harmonics up to the 40th order and to increment up to 8 tariff energy meters.

### Advanced protections

As an option, it is possible to use up to seven advanced protections to generate alarms or trip the circuit breaker in situations where the voltage, frequency, current or active power values exceed acceptable limits for the installation.

- undervoltage protection,
- overvoltage protection,
- underfrequency protection,
- overfrequency protection,
- reverse active power protection,
- current unbalance protection,
- voltage unbalance protection.

### Voltage monitoring alarms

As an option, the sentinel Energy trip unit allows alarms to be activated to monitor the electrical grid and provide alerts if there is a variation in voltage manifesting as a voltage dip or voltage peak in accordance with the IEC 61000-4-30 standard.

### Remote opening and closing operation of the hw+ circuit breaker

Thanks to coil and insulation module accessories, it is possible to initiate an opening or closing command from the Modbus communication or using the Hager Power touch mobile application.

### Neutral protection N

Neutral protection is factory-installed on 4-pole circuit breakers and as an option with the addition of the ENCT external neutral sensor on 3-pole versions. It is necessary if the neutral conductor cross section is less than that of the phases, or if the neutral conductor is heavily loaded (for example, in office buildings).

It uses similar tripping curve characteristics as the Long time delay, Short time delay and instantaneous protection parameters.

### Event management

The sentinel Energy trip unit generates events used to provide alarm warnings on the sentinel Energy display as well as other connected media: panel display, Hager Power touch application, Hager Power setup software.

These events are also used to generate a event history categorized in the following sections:

- Trip,
- Alarm,
- Optional alarm,
- Error,
- Diagnostic,
- Operation,
- Protection setting,
- Measurements settings,
- Test.

All log events are timestamped and recorded in the memory of the sentinel Energy trip unit.





**Hager Power touch mobile application**

The Hager Power touch mobile application displays status, measurement and settings information, and allows the circuit breaker to be remotely controlled in order to perform an opening or closing command.

It is compatible with the hw+ circuit breakers with the sentinel Energy trip unit.

This application is particularly useful for day-to-day operation and maintenance.

The Energy trip unit must be powered for it to establish the Bluetooth connection. Only one smartphone can be connected to a circuit breaker at a time.

The Hager Power touch mobile application allows access to a Home page showing the circuit breaker's principal characteristics, its operating state and maintenance information.

The other information and functions are described in the sections below:

 <p><b>Remote command</b> Close/open</p>	<p>allows the circuit breaker's opening or closing functions to be carried out.</p>
 <p><b>Voltage and current</b> ...</p>	<p>displays real-time voltage and current values.</p>
 <p><b>Quality of I...</b> Frequency, power fac...</p>	<p>displays frequency, power factor, harmonic distortion rate and individual harmonic values.</p>
 <p><b>Demand</b> Current and power</p>	<p>displays the current demand and power demand values.</p>
 <p><b>Power...</b> +Quadrant, phase rotation...</p>	<p>display the power and real-time energy measurement values as well as the power quadrant and phase sequence.</p>
 <p><b>Parameters</b> Overview of...</p>	<p>gives a read-only view of the values of the protection setting, advanced protections, alarms, electrical grid and the date and time of the circuit breaker.</p>
 <p><b>History</b> Overview of all events</p>	<p>display the events history by section.</p>

The application can be installed on a smartphone and downloaded from:

- Google Play Store for Android smartphones,
- App Store for iOS smartphones.



### Compatibility

The application is only available for Apple and Android smartphones.



The dedicated page on the App Store indicates the compatibility of the application with the various versions of iOS.

The dedicated page on the Google Play Store indicates the compatibility of the application with the various versions of Android.

The sentinel Energy electronic trip unit includes:

- A colour screen and a keyboard with six buttons allowing interaction with the trip unit
- A ReadyToProtect indicator: displays when the trip unit is operational and ready to protect. Pilot lamps allowing the cause of trips and alarms to be monitored.

The following characteristics are common to all the versions of the sentinel Energy electronic trip units:

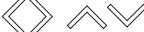
- ① Graphical colour display
- ② ReadyToProtect LED
- ③ Home  button
- ④ Acknowledgement and confirmation  button
- ⑤ Navigation buttons 
- ⑥ Rated current value  $I_n$  and indication of optional functions. This value is shown on the rating plug fitted on the trip unit.
- ⑦ USB-C port to connect an external power battery or a computer equipped with the Hager Power setup software.
- ⑧ Backup battery powering the display after electrical tripping. This enables the display to signal the tripping and its cause.
- ⑨ Backup battery housing cover.

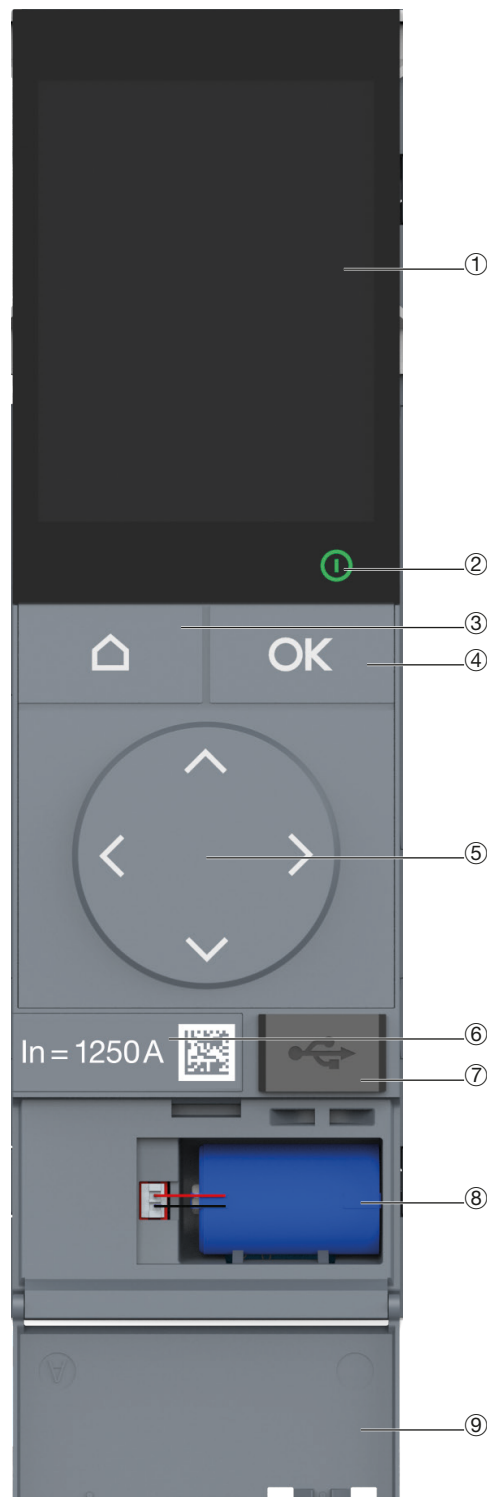

sentinel Energy  
electronic trip  
units

**ATTENTION**

The electronic trip unit must be powered in order to perform its protection function. It is powered as long as a minimum current of 20% of the nominal current  $I_n$  passes through the circuit breaker.  
Nevertheless, it is strongly recommended that a 24V DC SELV (recommended product reference Hager HTG911H) be connected on the TU terminal to guarantee optimal operation of the trip unit and prevent malfunctions in the electrical installation associated with a breach in the trip unit's continuity of operation.

The sentinel Energy display has 3 display zones:

High: position marker in the sequence of views available at this menu level, indication of Bluetooth activation,

Middle: information, message, relevant values,

Low: alarm icons and notifications of alarms

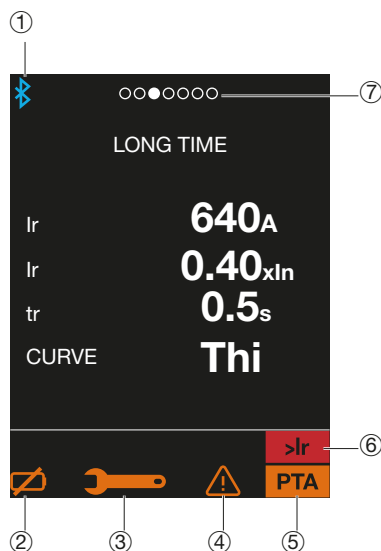

①	<b>Bluetooth</b>	appears as soon as the Bluetooth connection is activated.
②	<b>Low or missing backup battery alarm indicator</b>	displayed when the trip unit backup battery needs to be changed or is not connected.
③	<b>Maintenance alarm indicator</b>	appears when maintenance operations are required.
④	<b>System alarm indicator</b>	appears when a system alarm is present and the INFORMATION→ HISTORY ALARM menu has not been viewed yet.
⑤	<b>Overload pre-alarm indicator</b>	appears when the current crosses the PTA 1 threshold. Allows warnings about a risk of imminent overload.
⑥	<b>Overload alarm indicator</b>	flashes when the current exceeds 105 % of Ir and is constant when above 112.5 % of Ir. Allows warnings about a risk of imminent tripping.
⑦	<b>View marker</b>	indicates the positioning order of the screen in the view sequence.

**Live mode**

Live mode allows up to 15 favourite views to be continuously displayed among a list of 27 views available. These are views of measured values or protection setting values.



sentinel Energy  
electronic trip  
units

**Main menus**

You can switch to the main menus at any time to access settings parameters, measurement values and status and alarm information from the circuit breaker.

**Tree structure:**

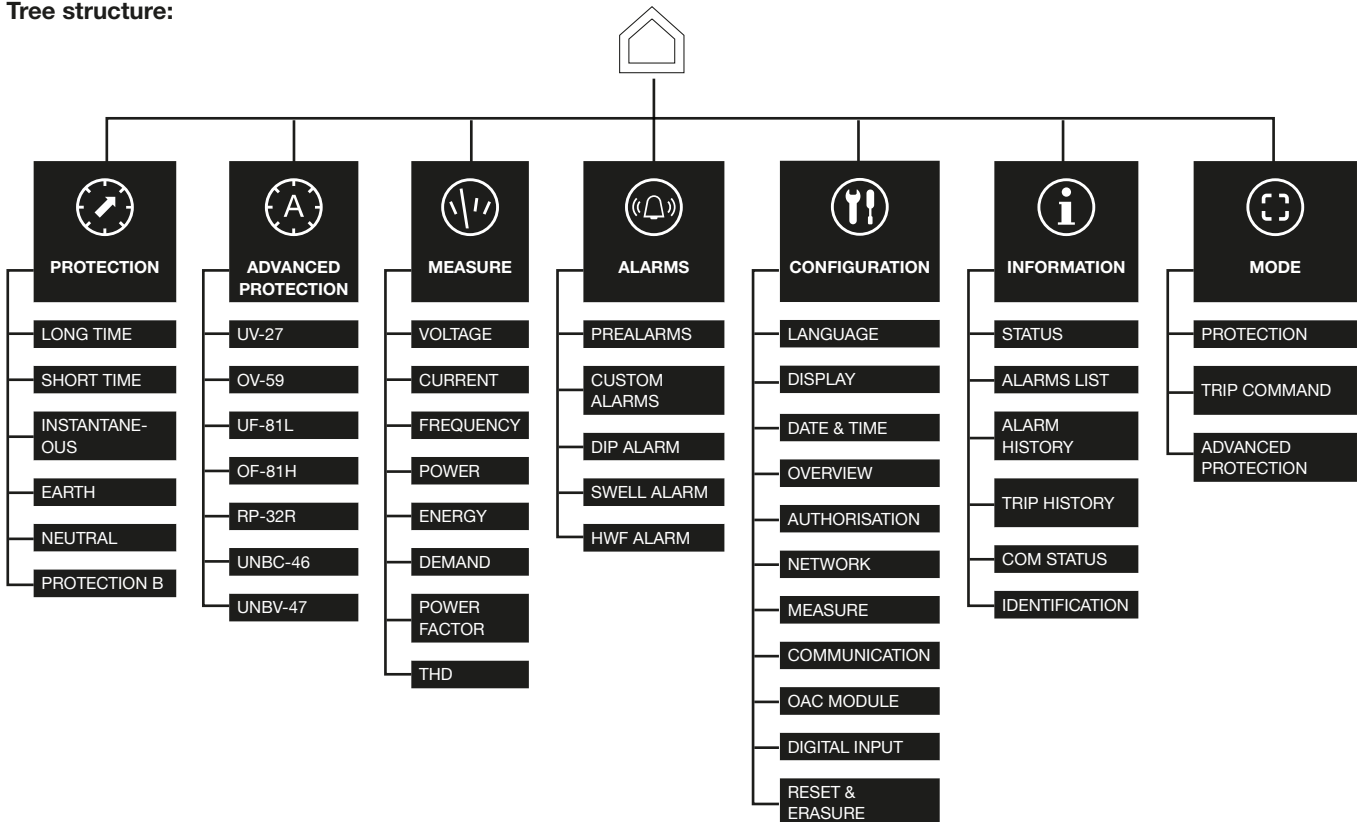

### LSI sentinel Energy trip unit

The LSI sentinel Energy trip unit is used to protect cables lines and equipment requiring a wide variety of protection settings.

The protection parameter settings are adjustable from the sentinel Energy display or the panel display or the Hager Power setup software.



### Neutral protection N

Neutral protection is factory-installed on 4-pole circuit breakers and as an option with the addition of the ENCT external neutral sensor on 3-pole versions. It is necessary if the neutral conductor cross section is less than that of the phases, or if the neutral conductor is heavily loaded (for example, in office buildings).

It uses similar tripping curve characteristics as the Long time delay, Short time delay and instantaneous protection parameters.

### Zone Selective Interlocking (ZSI)

Zone Selectivity (ZSI) is available on LSI sentinel Energy trip units. It can be used for short time delay protection (ZSI STD). The function is activated using the Hager Power setup software.

## LSI sentinel Energy trip unit

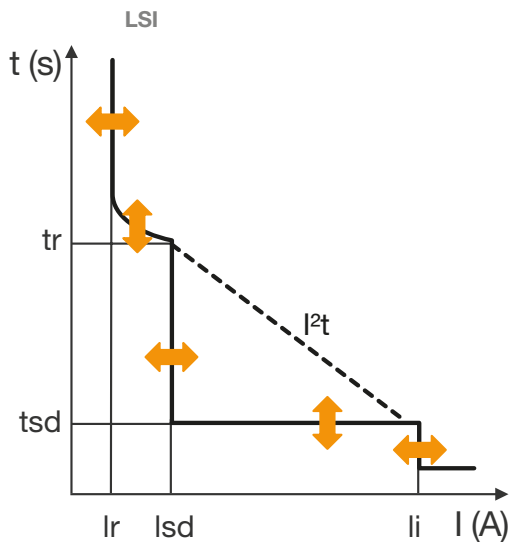

### Long Time Delay protection L (ANSI 49)

Trip curve	Thi	
Ir (tripping threshold between 1.05 and 1.20 x Ir)	0.40 to 1 x In in increments of 0.01	
Time delay (s)	tr	0.5 to 25 s in increments of 0.5 s
	accuracy	0 to +-20%

### Long Time Delay protection IEC 60255-151

Trip curve	SI $I^{0.02}t - VI t - EI I^2t - HVF I^4t$	
Ir	0.40 to 1 x In in increments of 0.01	
Time delay (s)	tr	0.5 to 25 s in increments of 0.5 s

### Short Time Delay protection STD (ANSI 50TD/51)

Activation	On/Off												
Isd	1 to 10 x Ir in increments of 0.5												
	accuracy	± 10%											
Time Delay (ms)	tsd	50	100	150	200	250	300	350	400	450	500	550	600
Non-tripping time (ms)		25	75	125	175	225	275	325	375	425	475	525	575
Maximum tripping time (ms)		100	150	200	250	300	350	400	450	500	550	600	650
Maximum break time (ms)		120	170	220	270	320	370	420	470	520	570	620	670

### Instantaneous Protection INST (ANSI 50)

Activation	On/Off												
li	1.5 to 15 x In in increments of 0.5												
	accuracy	± 15%											
Non-tripping time (ms)	20												
Maximum tripping time (ms)	80												
Maximum break time (ms)	100												

### Neutral protection N

Activation	On/Off												
Neutral protection = Phase protection Ir x ... phase protection Isd x ...	50 -100 - 150 - 200 %												
	Instantaneous protection	same as phases											
Time delay	same as phases for tr and instantaneous												

### LSIG sentinel Energy trip unit

The LSIG sentinel Energy trip unit is used to protect cable lines and equipment in TN earthing systems where earth fault protection is required.

The protection parameter settings are adjustable from the sentinel Energy display or the panel display or the Hager Power setup software.



### Neutral protection N

Neutral protection is factory-installed on 4-pole circuit breakers and as an option with the addition of the ENCT external neutral sensor on 3-pole versions. It is necessary if the neutral conductor cross section is less than that of the phases, or if the neutral conductor is heavily loaded (for example, in office buildings).

It uses similar tripping curve characteristics as the Long time delay, Short time delay and instantaneous protection parameters.

### Zone Selective Interlocking (ZSI)

Zone Selectivity (ZSI) is available on LSIG sentinel Energy trip units. It can be used for the Short Time Delay protection (ZSI STD) and the earth Fault protection (ZSI GF). The function is activated using the Hager Power setup software.



## LSIG sentinel Energy trip unit

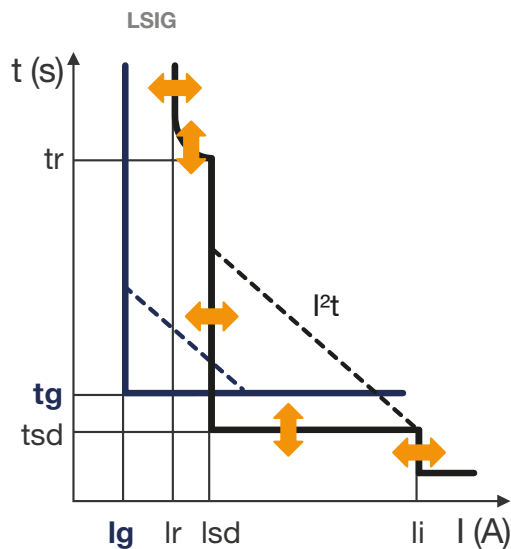

### Long Time Delay protection L (ANSI 49)

Trip curve		Thi
$I_r$ (tripping threshold between 1.05 and 1.20 x $I_n$ )		0.40 to 1 x $I_n$ in increments of 0.01
Time delay (s)	$t_r$	0.5 to 25 s in increments of 0.5 s
	accuracy	0 to +-20%

### Long Time Delay protection IEC 60255-151

Trip curve		$S I^{0.02} t - VI t - EI I^2 t - HVF I^4 t$
$I_r$		0.40 to 1 x $I_n$ in increments of 0.01
Time delay (s)	$t_r$	0.5 to 25 s in increments of 0.5 s

### Short Time Delay protection STD (ANSI 50TD/51)

Activation		On/Off
$I_{sd}$		1 to 10 x $I_r$ in increments of 0.5
	accuracy	± 10%
Time Delay (ms)	$t_{sd}$	50   100   150   200   250   300   350   400   450   500   550   600
Non-tripping time (ms)		25   75   125   175   225   275   325   375   425   475   525   575
Maximum tripping time (ms)		100   150   200   250   300   350   400   450   500   550   600   650
Maximum break time (ms)		120   170   220   270   320   370   420   470   520   570   620   670

### Instantaneous Protection INST (ANSI 50)

Activation		On/Off
$I_{li}$		1.5 to 15 x $I_n$ in increments of 0.5
	accuracy	± 15%
Non-tripping time (ms)		20
Maximum tripping time (ms)		80
Maximum break time (ms)		100

### GF earth fault protection (ANSI 50N TD/51N)

Activation		On/Off
$I_g$		1 to 10 x $I_r$ in increments of 0.5
	$I^2t$	± 10%
Time Delay (ms)	$t_g$	50   100   150   200   250   300   350   400   450   500   550   600
Non-tripping time (ms)		25   75   125   175   225   275   325   375   425   475   525   575
Maximum tripping time (ms)		100   150   200   250   300   350   400   450   500   550   600   650
Maximum break time (ms)		120   170   220   270   320   370   420   470   520   570   620   670

### Neutral protection N

Activation		On/Off
Neutral protection = Phase protection $I_r$ x ... phase protection $I_{sd}$ x ...		50 - 100 - 150 - 200 %
Instantaneous protection		same as phases
Time delay		same as phases for $t_r$ and instantaneous

The hw+ circuit breaker equipped with the sentinel Energy trip unit and embedded sensors is defined as a type PMD-DD measurement device of accuracy class 1 on power and energy measurements in accordance with the IEC 61557-12 version 2 standard.

The sentinel Energy trip unit makes available all the measurement values necessary for control and monitoring of the quality of the energy, energy management and energy efficiency.

The calculations are made in accordance with the requirements of the standard IEC/EN 61557-12:

- rms values of current and voltages,
- active, reactive and apparent powers,
- active, reactive and apparent energies,
- power factor,
- frequency,
- phase order,
- power quadrant,
- voltage unbalance,
- current unbalance,
- active, reactive and apparent powers,
- average current and power (current and power demand).

In addition to these measurement variables, the availability of the following variables depends on the type of rating plug installed.

Optional measurements	Meter Plus	Harmonic	Advanced	Ultimate
Measurement of total harmonic distortion THDV and THDV	■	■	■	■
Analysis of individual harmonics	-	■	-	■
Measurement of voltage unbalances	-	■	■	■
Multi-tariff energy meters	■	■	-	■

The average current (current demand) and average power (power demand) calculations are carried out in accordance with the IEC/EN 61557-12 standard. Average currents are calculated with the thermal integration method. The integration time constant is adjustable from 1 to 60 minutes in steps of 1 minute.

The average powers are calculated using arithmetic integration of the powers over a predefined period, divided by the length of this period. The average power calculations are carried out over a fixed period or a sliding period adjustable from 1 to 60 minutes in increments of 1 minute.

The calculated electrical values are available from the sentinel Energy display, the Bluetooth Hager Power touch application or the panel display. They are available via the Modbus communication.

They are refreshed every second.

The sentinel Energy trip unit records and timestamps the minimum and maximum values for voltage, current, frequency, power ... from the time of the last reset.

The minimum and maximum values can be reset from the sentinel Energy display, the panel display or the Hager Power setup software.

The voltages between phase and neutral are available for the 4-pole circuit breakers and also 3-pole circuit breakers if the neutral potential is connected to the VN terminal of the hw+ circuit breaker.

#### N.B.

In the case of a 3-pole circuit breaker equipped with a sentinel Energy trip unit and installed in a earth fault protection system where the neutral is distributed, the vN terminal must be connected to the neutral potential.

This connection is indispensable in order to obtain correct measured values for the V1N, V2N, V3N phase to neutral voltages, power per phase and for advanced reverse active power protection to function correctly, and undervoltage and overvoltage protection.

The list of measurement values available is as follows.

		sentinel Energy display	Panel display	Hager Power touch
<b>Measurements in real-time</b>				
<b>Voltages</b>				
phase-phase	U12, U23, U31	■	■	■
phase-neutral	V1N, V2N, V3N	■	■	■
Ph-Ph arithmetic mean	$U_{avg} = (U12 + U21 + U23) / 3$	■	■	■
Ph-N arithmetic mean	$V_{avg} = (V1N + V2N + V3N) / 3$	■	■	■
Instantaneous maximum	Voltages Ph-Ph and Ph-N	-	-	-
Instantaneous minimum	Voltages Ph-Ph and Ph-N	-	-	-
Unbalances Ph-Ph and Ph-N <sup>(1)</sup>	% $U_{avg}$ and % $V_{avg}$	■	■	■
Max. instant. unbalance <sup>(1)</sup>	Unba U, Unba V	-	■	-
Phase sequence	1-2-3, 1-3-2	■	■	■

(1) The availability of these measurements depends on the type of rating plug installed.

### Currents

Phase and neutral	I1, I2, I3, In	■	■	■
Arithmetic mean	$I_{avg} = (I1 + I2 + I3) / 3$	-	■	■
Instantaneous maximum	I <sub>max</sub> of I1, I2, I3, In	-	■	■
Instantaneous minimum	I <sub>min</sub> of I1, I2, I3	-	■	-
Earth fault	I <sub>g</sub>	■	■	■
Unbalance per phase	Inba1, Inba2, Inba3	■	■	■
Neutral unbalance	InbaN	-	■	■
Max. instant. unbalance	Inba	■	-	-

### Frequency

Frequency	f	■	■	■
Quadrant	I, II, III, IV	■	■	■
Rotary field	direct, inverse	■	■	■

### Power

Active	P total per phase	■	■	■
Reactive	Q total per phase	■	■	■
Apparent	S total per phase	■	■	■

### Energy

Total active energy imported/ exported (consumed/produced)	E <sub>aln</sub> / E <sub>aOut</sub>	■	■	■
Total reactive energy imported/ exported (consumed/produced)	E <sub>rIn</sub> / E <sub>rOut</sub>	■	■	■
Total active energy imported/ exported (consumed/produced) (partial counter)	E <sub>aln part</sub> / E <sub>aOut part</sub>	■	■	■
Total apparent energy	E <sub>s</sub>	■	■	■
Total net active energy	E <sub>a net</sub>	-	-	-
Total net reactive energy	E <sub>r net</sub>	-	-	-
Absolute value of the total net active energy	E <sub>a</sub>	-	-	-
Absolute value of the total net reactive energy	E <sub>r</sub>	-	-	-

		sentinel Energy display	Panel display	Hager Power touch
<b>Measurements in real-time</b>				
<b>Maximum and minimum values since last reset</b>				
Max. and min. of the phase-phase, phase-neutral and arithmetic mean voltages	max U12, max U23, max U32, min U12, min U23, min U31, max V1N, max V2N, max V3N, max Uavg, min Uavg, max Vavg, min Vavg	■	■	■
Max. of currents and arithmetic mean	max I1, max I2, max I3, max Iavg,	■	■	■
Min. of currents and arithmetic mean	min I1, min I2, min I3, min Iavg	■	-	■
Max. and min. of the voltage and current unbalances	max U12nba, max U23nba, max U32nba, min U12nba, min U23nba, min U31nba, max V1Nnba, max V2Nnba, max V3Nnba...	-	-	-
Max. of powers, max Ig	max P1 max P2, max P3, max Ptot,	■	■	-
Min. of powers, power factors, cos φ and min IG	min P1, min P2, min P3, min Ptot, min FP1, min FP2, min FP3, min FPtot, min cos φ1, min cos φ2, min cos φ3, min cos φtot	-	-	-
Max. of power factors, cos φ	max Ptot, max FP1, max FP2, max FP3, max FPtot, max cos φ1, max cos φ2, max cos φ3, max cos φtot,	-	-	-
Max. and min. of the THD of the voltages and currents	max THD U12, max THD U12, max THD U31, min THD U12, min THD U23, min THD U31, max THD V1N, max THD V2N, max THD V3N, min THD V1N...	-	-	-
Max. and min. of the frequency	max Freq, min Freq	-	-	■
Min. of the THD of In	min THD In	-	-	-
Max. of the THD of In	max THD In	■	■	-
<b>Averages over interval (demand)</b>				
Active (kW), reactive (kVAr), apparent (kVA) power demand	P Dmd, Q Dmd, S Dmd Total and per phase	total only	■	■
Peak power demand since last reset.	Max P Dmd, Max Q Dmd, Max S Dmd Total and per phase	total only	■	■
Current demand	I1 Dmd, I2 Dmd, I3 Dmd; In Dmd, Iavg Dmd	■	-	■
Peak current demand since last reset.	Max I1 Dmd, Max I2 Dmd, Max I3 Dmd; Max In Dmd	■	-	■
Integration interval sliding, fixed or synchronised by Modbus	Adjustable from 5 to 60 minutes in increments of one minute	■	■	■

Measurements in real-time		sentinel Energy display	Panel display	Hager Power touch
<b>Power factor</b>				
Power factor and $\cos \varphi$ (fundamental)	Total	■	■	■
Power factor and $\cos \varphi$ (fundamental)	Per phase	■	■	■
<b>Total harmonic distortion</b>				
Voltage THD <sup>(1)</sup>	THDU (Ph -Ph), THDV (Ph -N)	■	■	■
Current THD <sup>(1)</sup>	THDI per phase	■	■	■
THD In	Neutral THDI	■	■	■

(1) The availability of these measurements depends on the type of rating plug installed.

**Measurement accuracy**

The precision values are the result of the hw+ circuit breaker equipped with the sentinel Energy circuit breaker and the sensors:

Variables	Symbols	Measuring range	Class IEC 61557-12 or accuracy
Currents and Max./Min. current	I1, I2, I3; In, Iavg, Imax, Imin,...	0.2 x Ib ... Imax	0.5
Earth fault	% Ig	0.2 x Ib ... Imax	0.5
Current unbalance	Inba1, Inba2, Inba 3, InbaN, Inba	-	-
Phase-phase and Min/Max voltages	U12, U23, U31, Uavg	120 V - 690 V	0.5
Phase-neutral and Min/Max voltages	V1N, V2N, V3N, Vavg	70 V - 440 V	0.5
Unbalances	U12 Unb, U23 Unb, U31 Unb, V1N Unb, V2N Unb, V3N Unb, Max Unb U, Max Unb V	0.8...1.2 x Vn	-
Frequency	f	45 Hz - 65 Hz	0.02
Power	P total, P per phase, Q total, Q per phase, S total, S per phase	0.05 x Ib... Imax	1
Active energy	EaIn, EaOut, Ea Abs, Ea, EaIn EaOut	0.05 x Ib... Imax	1
Reactive energy	ErIN, ErOut, Er Abs, Er	0.05 x Ib... Imax	2
Apparent energy	Es	0.05 x Ib... Imax	1
Average power over interval	P Dmd per phase, P Dmd Total, Q Dmd per phase, Q Dmd Total, S Dmd per phase, S Dmd Total Max P Dmd per phase, Max P Dmd Total, Max Q Dmd per phase, Max Q Dmd Total, Max S Dmd per phase, Max S Dmd Total	0.05 x Ib... Imax	1
Average currents over interval	I1 Dmd, I2 Dmd, I3 Dmd, In Dmd, Iavg Dmd, Max I1 Dmd, Max I2 Dmd, Max I3 Dmd; Max In Dmd, Max I1 Dmd, Max I2 Dmd, Max I3 Dmd; Max In Dmd	0.2 x Ib ... Imax	0.5
Power factors	PF1, PF2, PF3, PFtot, Cos φ 1, Cos φ 2, Cos φ 3, Cos φ tot	0.5 inductive to 0.8 capacitive	1
Voltage THD	THDU (ph.-ph.), THDV (ph.-N)	0...20 %	2
Current THD	THDI per phase or per neutral pole	0...200 %	2

The seven following advanced protections are available as an option according to the type of optional rating plug installed:

	Meter Plus	Harmonic	Advanced	Ultimate
Undervoltage protection - ANSI 27	-	-	■	■
Overvoltage protection - ANSI 59	-	-	■	■
Underfrequency protection - ANSI 81L	-	-	■	■
Overfrequency protection - ANSI 81H	-	-	■	■
Reverse active power protection - ANSI 32R	-	-	■	■
Phase unbalance protection - ANSI 46	-	-	■	■
Voltage unbalance protection - ANSI 47	-	-	■	■

**N.B.**

For correct operation an external 24 V DC SELV power supply must be connected to the circuit breaker to allow the advanced protections to operate correctly.

### Undervoltage and overvoltage protection

The undervoltage protections (UV-27), ANSI 27 and overvoltage protections (OV59), ANSI 59 permanently monitor the installation voltage. When the voltage exceeds acceptable limits, the information provided by the protection allows alarms to be generated or the circuit breaker to be tripped.

#### Benefit

These protections are appropriate for generators.

In addition, continuous surveillance of phase-phase or phase-neutral voltages allows the appropriate action to be performed to secure the electrical installation, for example: load-shedding, power source switching, start of a backup generator.

#### Operating principle

These protections allow the three phase-phase voltages to be monitored or the three phase-neutral voltages.

They start at the end of the activation time delay when one of the three voltages reaches the activation threshold.

#### Undervoltage protection

	Activation	ANSI 27	On/Off
	Inhibition of the protection	ANSI 27	On/Off
	Voltage to be monitored, type U-V	ANSI 27	Choice of voltages to monitor: Three-phase voltages U12, U23, U31 or single voltages V1N, V2N, V3N
	Activation threshold $V_{min}$ (V)	ANSI 27	100 to 1000 V in increments of 5 V
	Accuracy	ANSI 27	+/- 1 %
	Activation time delay $tV_{min}$ (s)	ANSI 27	0.1 to 300 s in increments of 0.1
	Accuracy	ANSI 27	+/- 40 ms from 0.1 to 2 s +/-2 % above 2 s
	Hysteresis	ANSI 27	102 %
	Minimum tripping time (ms)	ANSI 27	60 ms
	Maximum tripping time (ms)	ANSI 27	140 ms with time delay set to 0.1 s

#### Overvoltage protection

	Activation	ANSI 59	On/Off
	Inhibition of the protection	ANSI 59	On/Off
	Voltage to be monitored, type U-V	ANSI 59	Choice of voltages to monitor: Three-phase voltages U12, U23, U31 or single voltages V1N, V2N, V3N
	Activation threshold $V_{max}$ (V)	ANSI 59	100 to 1000 V in increments of 5 V
	Accuracy	ANSI 59	+/- 1 %
	Activation time delay $tV_{max}$ (s)	ANSI 59	0.1 to 300 s in increments of 0.1
	Accuracy	ANSI 59	+/- 40 ms from 0.1 to 2 s +/-2 % above 2 s
	Hysteresis	ANSI 59	98 %
	Minimum tripping time (ms)	ANSI 59	60 ms
	Maximum tripping time (ms)	ANSI 59	140 ms with time delay set to 0.1 s

#### Underfrequency and overfrequency protections



The underfrequency protections (UF-81L), ANSI 81L and overfrequency protections (OF-81H), ANSI 81H permanently monitor the installation voltage. When the frequency exceeds acceptable limits, the information provided by the protection allows alarms to be generated or the circuit breaker to be tripped.

### Benefit

The frequency of an electrical installation must be maintained within a strict operating range to limit the risk of damaged caused to the motor loads and sensitive electronic equipment and to maintain a good performance level of the loads. These protections are appropriate for generators.

In addition, continuous monitoring of the frequency allows the appropriate action to be performed to secure the electrical installation, for example: load-shedding, power source switching, start of a backup generator.

### Operating principle

These protections start at the end of the activation time delay when the measured frequency reaches the activation threshold.

#### Underfrequency protection

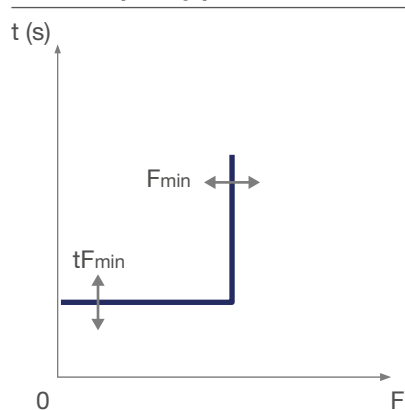

	ANSI 81L
Activation	On/Off
Inhibition of the protection	On/Off
Activation threshold $F_{min}$ (Hz)	45.0 to the nominal frequency $F_n$ in increments of 0.1
Accuracy	+/- 0.1 Hz
Activation time delay $t_{F_{min}}$ (s)	0.1 to 300 s in increments of 0.1
Accuracy	+/- 40 ms from 0.1 to 2 s +/- 2 % above 2 s
Hysteresis	102 %
Minimum tripping time (ms)	60 ms
Maximum tripping time (ms)	140 ms with time delay set to 0.1 s

#### Overfrequency protection

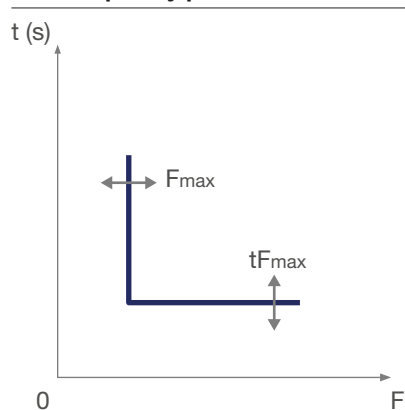

	ANSI 81H
Activation	On/Off
Inhibition of the protection	On/Off
Activation threshold $F_{max}$ (Hz)	From the nominal frequency $F_n$ to 65.0 Hz in increments of 0.1
Accuracy	+/- 0.1 Hz
Activation time delay $t_{F_{max}}$ (s)	0.1 to 300 s in increments of 0.1
Accuracy	+/- 40 ms from 0.1 to 2 s +/- 2 % above 2 s
Hysteresis	98 %
Minimum tripping time (ms)	60 ms
Maximum tripping time (ms)	140 ms with time delay set to 0.1 s

#### Reverse active power protection

The reverse active power protection (RP-32R), ANSI 32R detects when a synchronous power generator connected in parallel to other sources is functioning as a synchronous motor.

### Benefit

It enables the circuit breaker to be tripped to disconnect the generator from other sources or it can also be used to monitor the active power exchanged between two sources and generate an alarm to take a load-shedding measure or to trip once the flow coming back from the active power exceeds the fixed value.

### Operating principle

The reverse active power protection is based on the measurement.

The sentinel Energy trip unit assigns the sign + or - to the active power according to the power sign convention parameter.

By default this parameter is set for a situation where the power source of the installation is connected upstream of the circuit breaker (circuit breaker powered upstream).

When the power source is connected downstream (circuit breaker powered downstream) the power sign convention parameter must be changed to enable the reverse active power protection to operate correctly.

It starts when the total active power is negative, when the power threshold is reached and when the activation time delay has elapsed.

### Reverse active power protection

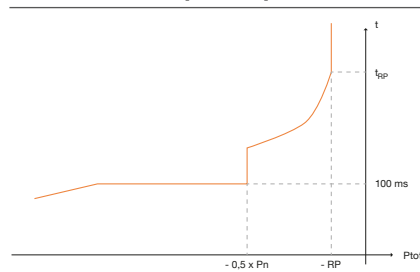

### ANSI 32R

Activation	On/Off
Inhibition of the protection	On/Off
Activation threshold RP (% x P <sub>n</sub> )	4.0 to 15.0 % x P <sub>n</sub> in increments of 0.5
Accuracy	0 % to -20 %.
Activation time delay t <sub>RP</sub> (s)	0.5 to 25 s in increments of 0.5
Accuracy	- 15 % to + 15 % + 100 ms
Minimum tripping time (ms)	425 ms
Maximum tripping time (ms)	675 ms with time delay set to 0.5 s

**Current unbalance protection**

The current unbalance protection (UNBC-46), ANSI 46 permanently monitors the current unbalances of each phase. When the unbalance is detected on one of the phases, the UNBC-46 protection allows an alarm to be generated or the circuit breaker tripped.

**Benefit**

The unbalances in phase currents generate significant heating and braking torques that can cause the motor to degrade prematurely.

Current unbalance protection is recommended for a motor.

**Operating principle**

Current unbalance protection calculates the current unbalances for each phase, in relation to the average current, expressed as a percentage:

$$I_{nbaP}[\%] = 100 * \frac{I_p - I_{avg}}{I_{avg}} \text{ with } P = 1, 2, 3$$

$$I_{avg} = \frac{I_1 + I_2 + I_3}{3}$$

Example of maximum positive unbalance on phase 2:

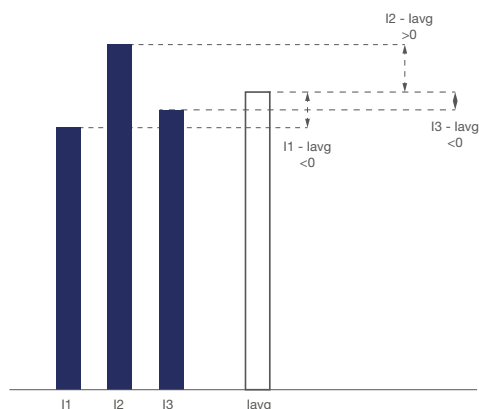

sentinel Energy  
electronic trip  
units

**Current unbalance protection**

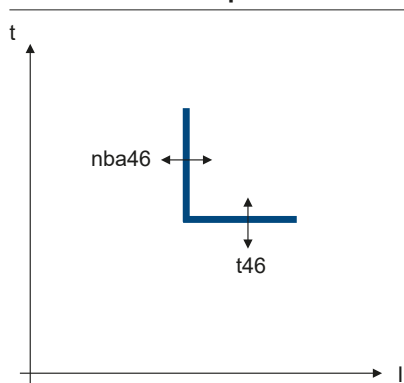

	ANSI 46
Activation	On/Off
Inhibition of the protection	On/Off
Activation threshold nba46 (%)	2 to 90 % in increments of 1
Accuracy	+/- 5 units, for example for a 20 % threshold the accuracy will be between 15 % and 25 %
Activation time delay t46 (s)	0.5 to 60.0 s with steps of 0.1
Accuracy	+/- 40 ms from 0.1 to 2 s +/- 2 % above 2 s
Hysteresis	98 %
Minimum tripping time (ms)	60 ms
Maximum tripping time (ms)	140 ms with time delay set to 0.5 s

### Voltage unbalance protection

The voltage unbalance protection (UNBV-47), ANSI 47 permanently monitors the voltage unbalances of each phase. When the unbalance is detected on one of the phases, the UNBV-47 protection allows an alarm to be generated or the circuit breaker tripped.

### Benefit

The voltage unbalances in a 3-phase system are caused by the connection of too many 1-phase loads on a single phase. These unbalances can cause major problems for those administering the electrical grid.

Voltage unbalances also have an influence on all three-phase equipment and in particular on motors, because they then experience undesirable braking torque which then takes the form of overheating. Any voltage unbalance greater than 2% results in overheating of equipment, which makes it necessary for the latter to be overdimensioned to compensate for the overheating and prevent premature degradation.

### Operating principle

Current unbalance protection calculates the voltage unbalances for compound voltages, in relation to the average current, expressed as a percentage:

$$U_{nbapP}[\%] = 100 * \frac{U_{p-p} - U_{avg}}{U_{avg}} \text{ with } P = 1, 2, 3$$

$$U_{avg} = \frac{U_{12} + U_{23} + U_{31}}{3}$$

Example of voltage unbalance on phase 2:

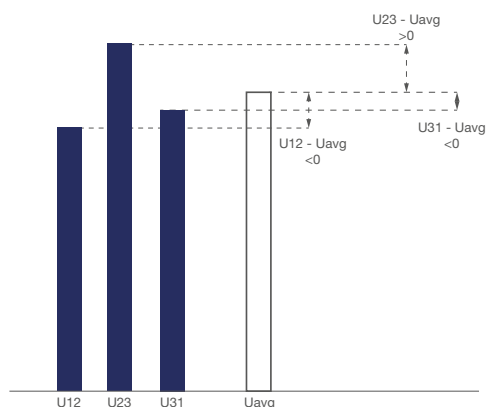

### Voltage unbalance protection

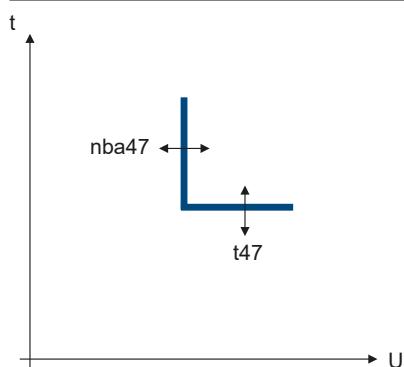

### ANSI 47

Activation	On/Off
Inhibition of the protection	On/Off
Activation threshold nba47 (%)	2 to 90 % in increments of 1
Accuracy	+/- 2 units, for example for a 20 % threshold the accuracy will be between 18 % and 22 %
Activation time delay t47 (s)	0.5 to 60.0 s with steps of 0.1
Accuracy	+/- 40 ms from 0.1 to 2 s +/- 2 % above 2 s
Hysteresis	98 %
Minimum tripping time (ms)	60 ms
Maximum tripping time (ms)	140 ms with time delay set to 0.5 s

# Configuration and referencing

	Page
<b>01 Configuration</b>	<b>80</b>
<b>02 Referencing</b>	<b>81</b>
<b>03 Testing and commissioning</b>	<b>83</b>

## Order your Hager air circuit breaker via the Hagercad configurator.

Whatever the size of your project (commercial buildings, public infrastructure), save time with the Hagercad configurator to generate your list of equipment, your connecting diagram, enclosure drawings and commercial quote.

## Fast, comprehensive and smart, Hagercad is the essential tool to configure your air circuit breaker:

**Quick:** You have clear visibility over your projects and the products used.

**Comprehensive:** all the characteristics (breaking capacity, rated current, type of electronic trip unit, etc.) for your air circuit breaker can be selected based on your needs.

**Intelligent:** No more risk of errors, the software checks your installation according to the IEC 61439 standard.

For all of this:

1/ Visit your local Hager website for more information.

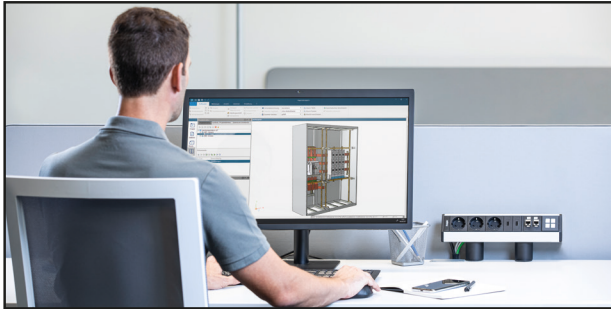

2/ Configure the air circuit breaker according to your needs.

## hw+ web configurator

The hw+ web configurator allows easy configuration of the hw+ circuit breaker according to the installation requirements. It allows the characteristics of the circuit breaker to be chosen, the trip unit type, accessories for control, signalling, interlocking, etc.

## Interface and configuration rules

Thanks to its user-friendly, intuitive interface, selecting components and accessories is quick.

The cascading rules save time when selecting and validating the final configuration.

A new configuration can be created or edited in different ways:

- By following the steps on the form,
- Using a **Product Code** configuration identifier,
- By reusing a saved configuration.

To start using the **hw+ web configurator** visit your local Hager website.

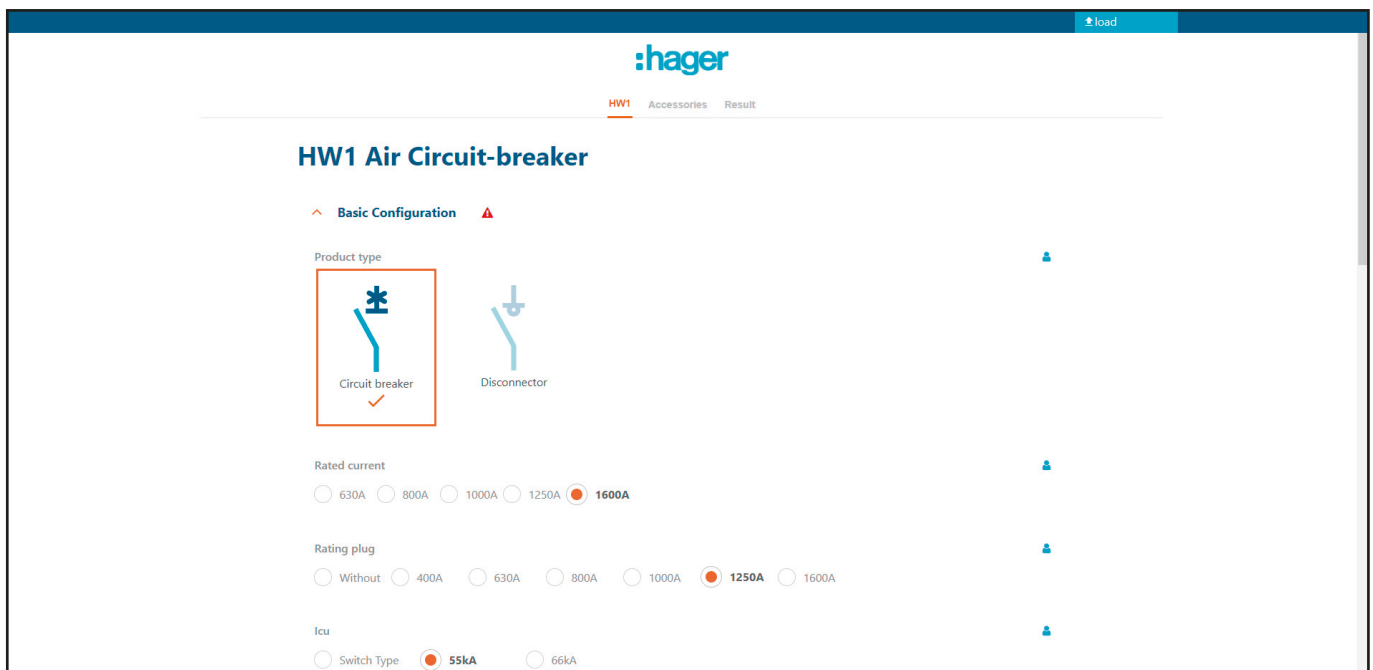

hw+ web configurator

At the end of the process, an identification code corresponding to the configuration of your circuit breaker is created. This code is specific to the characteristics you have determined.

Below are the first characters of this codification:

		H	W	x	x	x	xx	x	x
<b>hw+ frame sizes</b>	HW1 up to 1600A			1					
	HW2 up to 2500A			2					
	HW4 up to 4000A			4					
	HW6 up to 6300A			6					
<b>Breaking capacity</b>	42 kA				N				
	55 kA				M				
	66 kA				E				
	100 kA for HW2 / 85 kA for HW4				S				
	120 kA				P				
	150 kA				L				
	Switch-disconnectors				W				
<b>Number of poles</b>	3-pole						3		
	4-pole						4		
<b>Rated current</b>	400 A							04	
	630 A							06	
	800 A							08	
	1000 A							10	
	1250 A							12	
	1600 A							16	
	2000 A							20	
	2500 A							25	
	3200 A							32	
	4000 A							40	
	5000 A							50	
	6300 A							63	
<b>Model</b>	Drawout								D
	Fixed								F
<b>Trip unit type</b>	Without trip unit ( Switch-disconnector)								S
	sentinel LI, LSI or LSIG								B
	sentinel Energy LSI or LSIG								E

	<b>Icu (380-440 VAC)</b>			
	<b>HW1</b>	<b>HW2</b>	<b>HW4</b>	<b>HW6</b>
N	42 kA	-	-	-
M	55 kA	55 kA	-	-
E	66 kA	66 kA	66 kA	-
S	-	100 kA	85 kA	-
P	-	-	120 kA	-
L	-	-	-	150 kA

This gives a unique identification code of the type:  
HW1M310DB XXXXX XXXXX XXXXXX XXXX

This is the image of your circuit breaker and will facilitate your communication with Hager and product identification:

- If you want an identical circuit breaker, just provide your code with your next order.
- If you want to know the configuration of a circuit breaker, note its code and refer to the referencing rule provided above.

You can find it:

On the packaging labels:

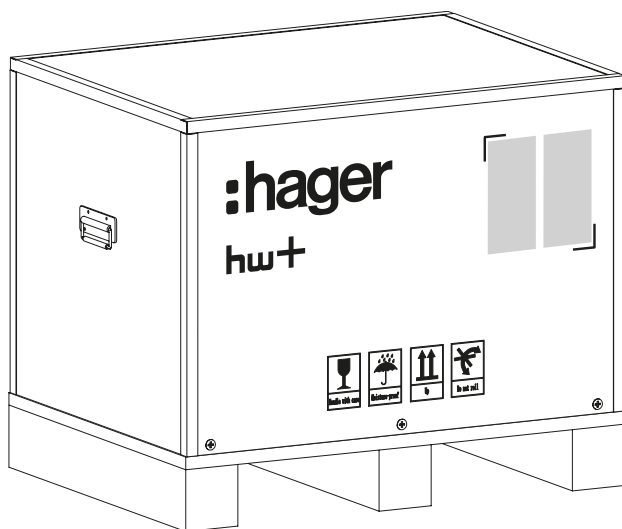

On the side of the circuit breaker:

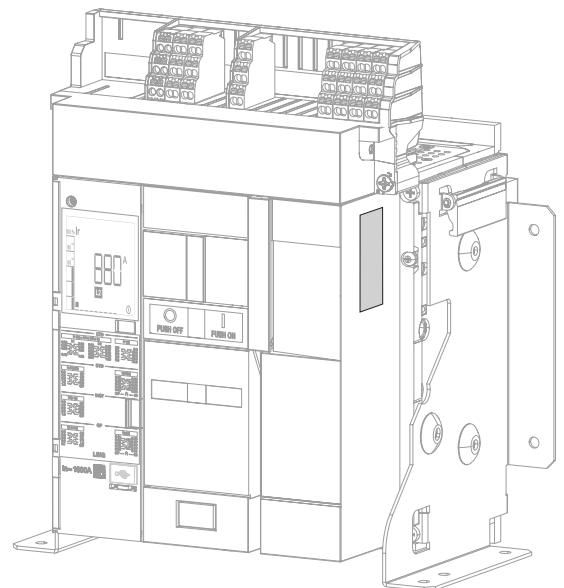
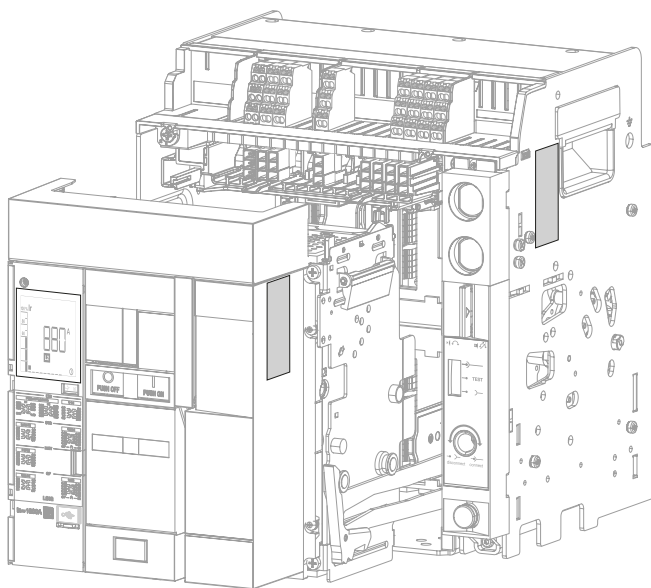



The Hager Power setup software has been designed for testing and commissioning hw+ trip units.

Thanks to the commissioning menu, it is possible to specifically generate a commissioning report proving that the protection settings comply with the short-circuit and selectivity calculations. This requires the settings to be imported from the Hagercad software.

It offers a smart way of creating the protection settings. It also allows all the trip unit parameter settings to be displayed and modified.

It is possible to perform a test of the hw+ circuit breakers tripping curve.

It also allows a forced electro-mechanical tripping of the circuit breakers to be performed.

It is very useful during the test phase when wiring the output contacts. It makes it possible to force the opening or closing of the OAC and ZSI output contacts.

The result of the different tests can be entered into a test report that can be generated at any time whether in the wiring workshop or during acceptance tests on site.

The functions of the Hager Power setup software can be accessed through six menus:

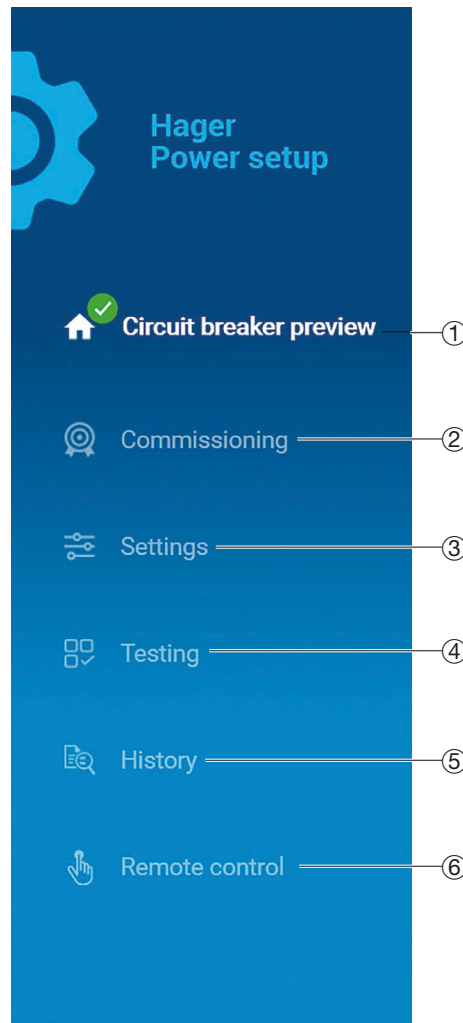

- ① Functional state of the circuit breaker, maintenance information and principal technical characteristics.
- ② Three-stage procedure 1. Setting, 2. Test, 3. Tripping, to commission the circuit breaker using settings data imported from the Hagercad software. Allows a commissioning report to be generated.
- ③ Access to all the parameter settings of the trip unit, alternative to commissioning ②.
- ④ Access to the tripping curve of the manual test, the forced electro-mechanical tripping and activation of the output contacts available on the circuit breaker. Allows a test report to be generated.
- ⑤ Access to event history. Display of active alarms. Operating counters panel.
- ⑥ Access to remote controls available on the sentinel Energy circuit breaker: remote opening or closing, switch between protection profiles, inhibition of advanced protections.

**Principal functions**

- Display the functional state of the circuit breaker, maintenance information and principal technical characteristics.
- Perform a commissioning by importing settings from Hagercad.
- Generate and print test reports and commissioning reports.
- Perform a manual test of the tripping curve of the hw+ circuit breakers.
- Perform a forced electro-mechanical tripping of the circuit breakers.
- Display and modify all the electronic trip unit parameter settings.
- Display alarms in progress.
- Download and export the electronic trip unit settings in a file in CSV format.
- Save the settings of a circuit breaker from within the Energy family to load them into one or more similar circuit breakers.
- Force the opening or closing of the OAC and ZSI output contacts.
- Display the active alarms.
- View the event logs and export them in a file in CSV format.
- Display the status of the operating counters available (handling cycles, tripping operations...).

The Hager Power setup software is available on the Hager website for your country.

**IT configuration required**

	Minimal	Recommended
<b>Operating system</b>	Windows 10 x32 bits	Windows 10 x64 bits
<b>Memory</b>	4 Gb RAM	8 Gb RAM
<b>Disk space</b>	50 Mb	50 Mb
<b>Components</b>	Microsoft .NET Framework 4.7.2 .NET Core Runtime 3.1.13 .NET Desktop Runtime 3.1.13 Microsoft web view 2 v1.0.818.14	Microsoft .NET Framework 4.7.2 or higher .NET Core Runtime 3.1.13 or higher .NET Desktop Runtime 3.1.13 or higher Microsoft web view 2 v1.0.818.14 or higher
<b>Resolution</b>	1024x768 pixels	1280x1024 pixels

# Accessories

	Page
<b>01 List of accessories</b>	<b>86</b>
<b>02 Connection accessories</b>	<b>87</b>
<b>03 Control accessories</b>	<b>88</b>
<b>04 Signalling accessories</b>	<b>95</b>
<b>05 Locking and interlocking accessories</b>	<b>102</b>
<b>06 Power connection accessories</b>	<b>111</b>
<b>07 Protection accessories</b>	<b>118</b>
<b>08 Communication accessories</b>	<b>121</b>

	Withdrawable				Fixed		
	Size				Size		
	HW1	HW2	HW4	HW6	HW1	HW2	HW4
<b>Connection accessories - Page 87</b>							
TB terminal block connection	•	•	•	•	•	•	•
<b>Control accessories - Page 88</b>							
SH shunt trip coil	•	•	•	•	•	•	•
CC closing coil	•	•	•	•	•	•	•
UV undervoltage release coil	•	•	•	•	•	•	•
UVTC Time Delay controller for undervoltage release coil	•	•	•	•	•	•	•
MO charging motor	•	•	•	•	•	•	•
<b>Signalling accessories - Page 95</b>							
AX auxiliary contact	•	•	•	•	•	•	•
FS fault trip contact	•	•	•	•	•	•	•
OAC output alarm contacts module	•	•	•	•	•	•	•
PS position contact (only for withdrawable version)	•	•	•	•			
RTC ready-to-close-contact	•	•	•	•	•	•	•
CYC cycle counter	•	•	•	•	•	•	•
<b>Locking and interlocking accessories - Page 102</b>							
WIP wrong insertion preventer for withdrawable circuit breaker	•	•	•	•			
Safety shutters	•	•	•	•			
RI open door racking interlock	•	•	•	•			
Locking of the circuit breaker in OFF by OLP padlock or OLK key lock	•	•	•	•	•	•	•
Locking the position of the circuit breaker in its CL chassis	•	•	•	•			
MI mechanical interlock	•	•	•	•	•	•	•
PBC push button cover	•	•	•	•	•	•	•
<b>Power connection accessories - Page 111</b>							
Rear vertical / horizontal RC HW1 connections	•	•	•	•	•	•	•
FC HW1 front sockets	•				•		
VCA HW1 vertical connectors	•				•		
Spreaders SP HW1	•				•		
B	•	•	•	•	•	•	•
<b>Protection accessories - Page 118</b>							
TBC terminal cover	•	•	•	•			
DF door frame	•	•	•	•	•	•	•
Air chamber screen HW1					•		
ENCT external neutral sensor	•	•	•	•	•	•	•
<b>Communication accessories - Page 121</b>							
Communication modules	•	•	•	•	•	•	•
Panel display	•	•	•	•	•	•	•
INS insulation module for SH coil and CC coil	•	•	•	•	•	•	•
Position sensor	•	•	•	•			

**TB terminal block connection**

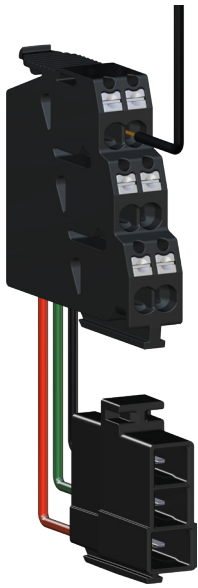

TB terminal block with QuickConnect system

This terminal block has QuickConnect technology, facilitating the wiring of the control and signalling accessories:

- Time-saving: wiring is quick and easy thanks to the QuickConnect technology, and can be done quickly and easily, tool-free.
- Contact safety: no unlocking, no maintenance.
- Test point: for measuring devices with touch probes.
- Cable disconnection: the QuickConnect terminal can be released quickly and easily with a screwdriver.

There is a choice of three types of terminal block depending on the accessory to be connected:

Description	Characteristics	
Connection terminal block	A-type	For AX auxiliary contact, FS fault trip contact, RTC ready-to-close-contact, MO charging motor, SH shunt trip coil, CC closing coil, UV undervoltage release coil
	B-type	For ENCT external neutral sensor
	C-type	For ZSI contact, OAC output alarm contacts module

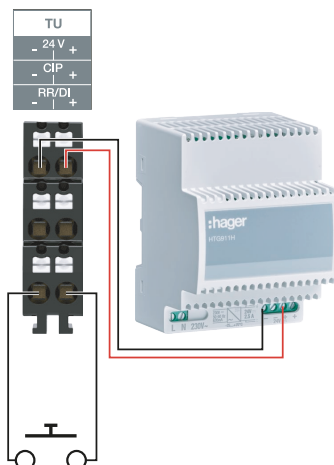

hw+ open circuit breakers are fitted by default with:

- 4 AX auxiliary contacts (HW1 and HW2) and 6 auxiliary contacts (HW4 and HW6) as well as the associated TB connection terminal blocks,
- 1 FS fault trip contact as well as the associated TB terminal block connection,
- connection terminal blocks for ZSI function,
- 1 TU connection terminal block at the electronic trip unit. This terminal block allows an external 24V DC power supply to be connected and a remote reset circuit to be plugged in at the RR digital input.

Any configuration other than this default configuration may require one or more additional connection terminal blocks.

The cables used must have a cross section between 0.6mm<sup>2</sup> and 2.5mm<sup>2</sup>. They can be flexible or rigid.

In order to be correctly maintained in the terminal blocks, the connected cables must be stripped in advance by 10 to 12 mm. The flexible cables can be inserted without end caps and must not be twisted.

## Control accessories overview

Control accessories are used to perform circuit breaker opening, charging and closing control operations.  
The command is carried out:

- locally via the charging handle and the opening and closing push-buttons,
- remotely via the TB terminal block connections of the control accessories.

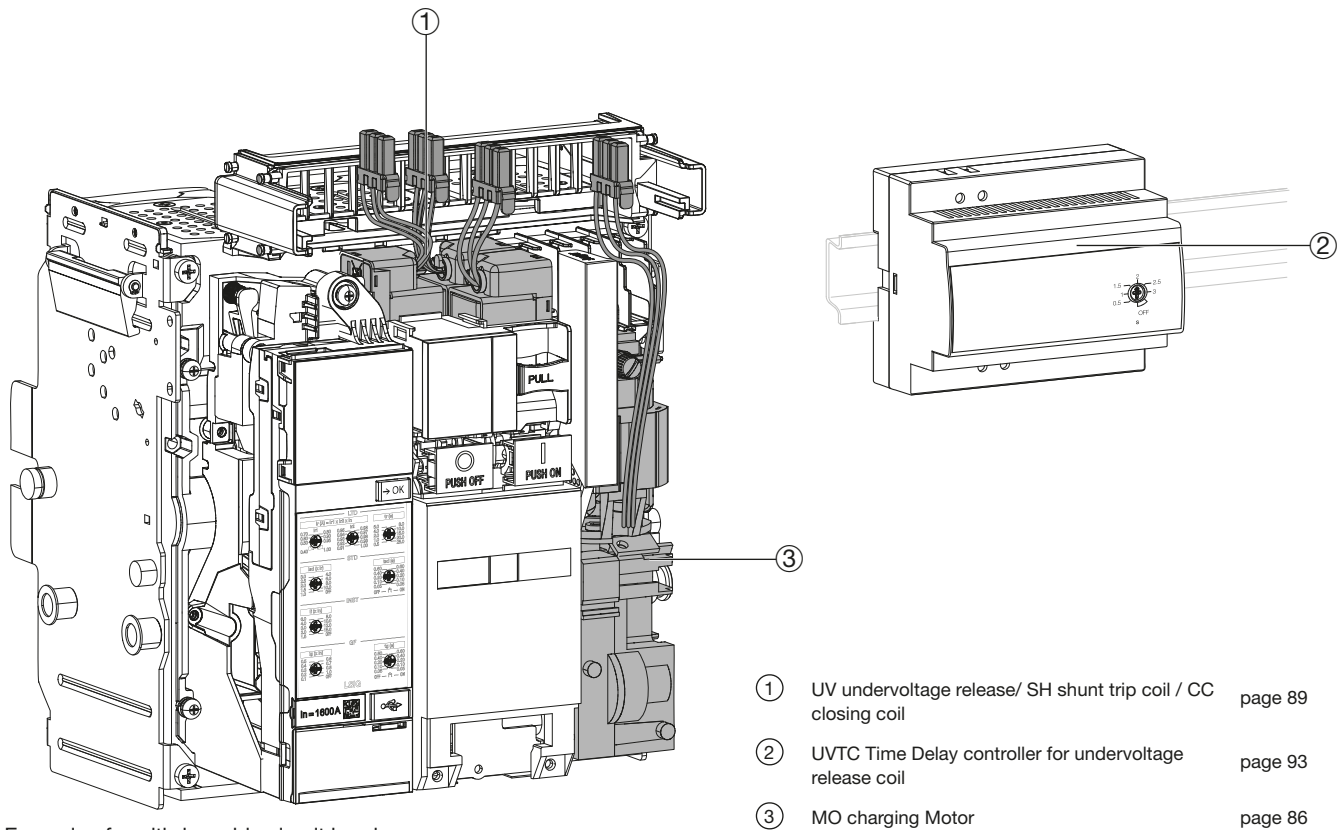

Example of a withdrawable circuit breaker

- ① UV undervoltage release/ SH shunt trip coil / CC closing coil page 89
- ② UVTC Time Delay controller for undervoltage release coil page 93
- ③ MO charging Motor page 86

### Location on the terminal block support

UV/SH2	SH/UV2	MO	CC
D12 <small>C22</small>	C12 <small>D22</small>	M2	A2
<small>C23</small>	C13	M4	A3
D11 <small>C21</small>	C11 <small>D21</small>	M1	A1

**UV undervoltage release/ SH shunt trip coil / CC closing coil**



The SH coils are used to remotely open the circuit breaker and the CC closing coil is used to remotely close the circuit breaker.

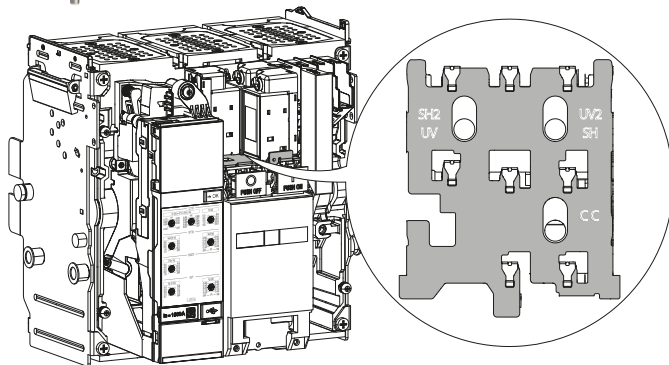

UV, SH and CC coils are fitted behind the front cover of the circuit breaker.

They are equipped with connectors to be placed in their respective positions.

The connection takes place by means of QuickConnect terminals with a flexible or rigid cable of cross-section 0.6 to 2.5 mm<sup>2</sup>.

Plate for mounting coils

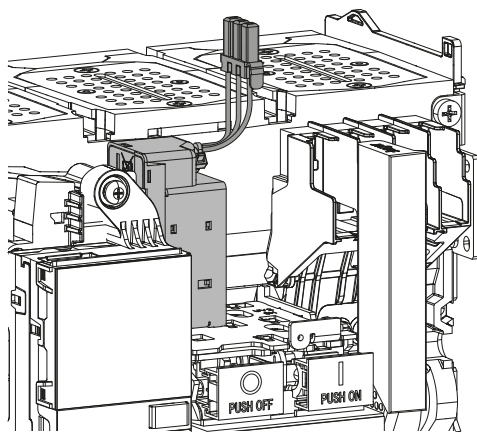

UV undervoltage release coil the SH2 / UV position

**UV undervoltage release coil**

The UV undervoltage coil activates the circuit breaker opening mechanism when it is no longer supplied or when its rated voltage drops between 70% and 40%.

The circuit breaker can only close if the coil supply voltage returns to normal or exceeds a defined threshold.

It is possible to add a UVTC time delay controller to the UV undervoltage release coil to delay the operation of the coil and thus reduce unwanted tripping of the circuit breaker.

**Electrical characteristics of UV undervoltage release coil**

Rated voltage (Vn)		Closing voltage (V)	Opening voltage (V)	Frequency (Hz)	Electricity consumption (VA)		Circuit breaker response time at Vn (ms)
DC (V)	AC (V)				Inrush	Holding	
24-30		> 21	8-21	50/60	300 (200 ms)	5	less than 90
48-60		> 41	17-42	50/60			
100-130		> 85	35-91	50/60			
200-250		> 170	70-175	50/60			
-	380-480	> 323	133-336	50/60	200 (200 ms)		

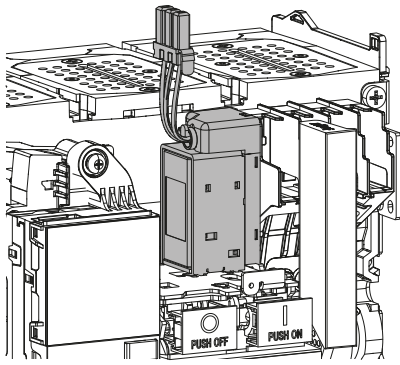

SH shunt trip coil in the UV2 / SH position

### SH shunt trip coil

The SH shunt trip coil activates the circuit breaker opening mechanism when it is energised.

A second SH shunt trip coil can be installed in the SH2 mounting device.

The pulse duration must be at least 100 ms. The coil is suitable for continuous supply.



N.B. If this second coil is installed, it is no longer possible to install a second UV undervoltage release coil.

### Electrical characteristics of the SH shunt trip coil

Rated voltage (Vn)		Operating range (V)	Frequency (Hz)	Electricity consumption (VA)		Circuit breaker response time at Vn (ms)
DC (V)	AC (V)			Inrush	Holding	
24-30		17-33	50/60	300 (200 ms)	5	50
48-60		34-66	50/60			
100-130		70-143	50/60			
200-250 (1)		140-275	50/60	200 (200 ms)		
-	380-480 (2)	266-528	50/60			

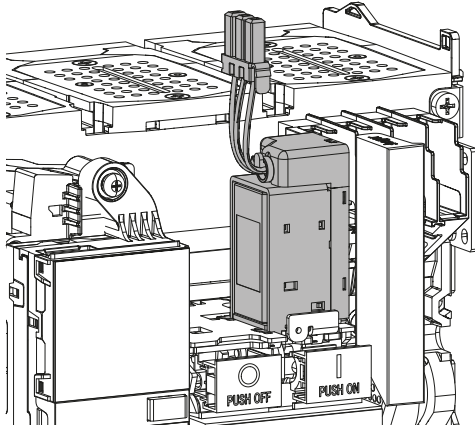

CC closing coil in its position

### CC closing coil

The CC closing coil activates the circuit breaker closing mechanism when it is energised. The pulse duration must be at least 100 ms. The coil is suitable for continuous supply.

### Electrical characteristics of the CC closing coil

Rated voltage (Vn)		Operating range (V)	Frequency (Hz)	Electricity consumption (VA)		Circuit breaker response time at Vn (ms)
DC (V)	AC (V)			Inrush	Holding	
24-30		21-33	50/60	300 (200 ms)	5	less than 80
48-60		41-66	50/60			
100-130		85-143	50/60			
200-250 (1)		170-275	50/60	200 (200 ms)		
-	380-480 (2)	323-528	50/60			



**Connecting coils for local control  
with a sentinel or sentinel Energy trip unit.**

A jumper of less than 10 cm must be fitted as close as possible to the terminal block between Cx2 and Cx3 (SH or SH2 transmitting coil) and/or A2 and A3 (DC closing coil).

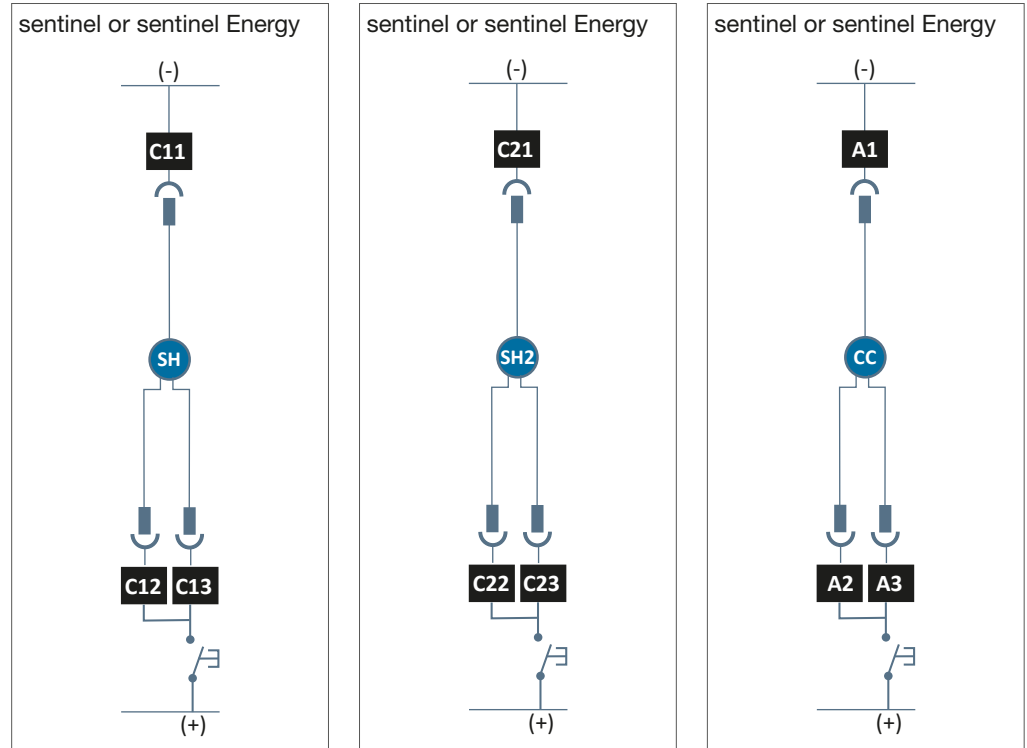

**Warning** this type of wiring does not allow remote control of the coils on a circuit-breaker fitted with an Energy trip unit.

**Connection of coils for local or remote control with an Energy sentinel trip unit.**

Remote control is available via :

- Modbus if a communication module is installed,
- Hager Power touch Bluetooth application
- The Hager Power setup software
- and only with a sentinel Energy trip unit

The length of the connection cables between:

- the terminals Cx2 and Cx3 of the SH shunt trip coils,
  - the terminals A2 and A3 of the CC closing coils,
- is limited to 5 m for the 200-250 V coils (beyond that, an intermediate relay is necessary).

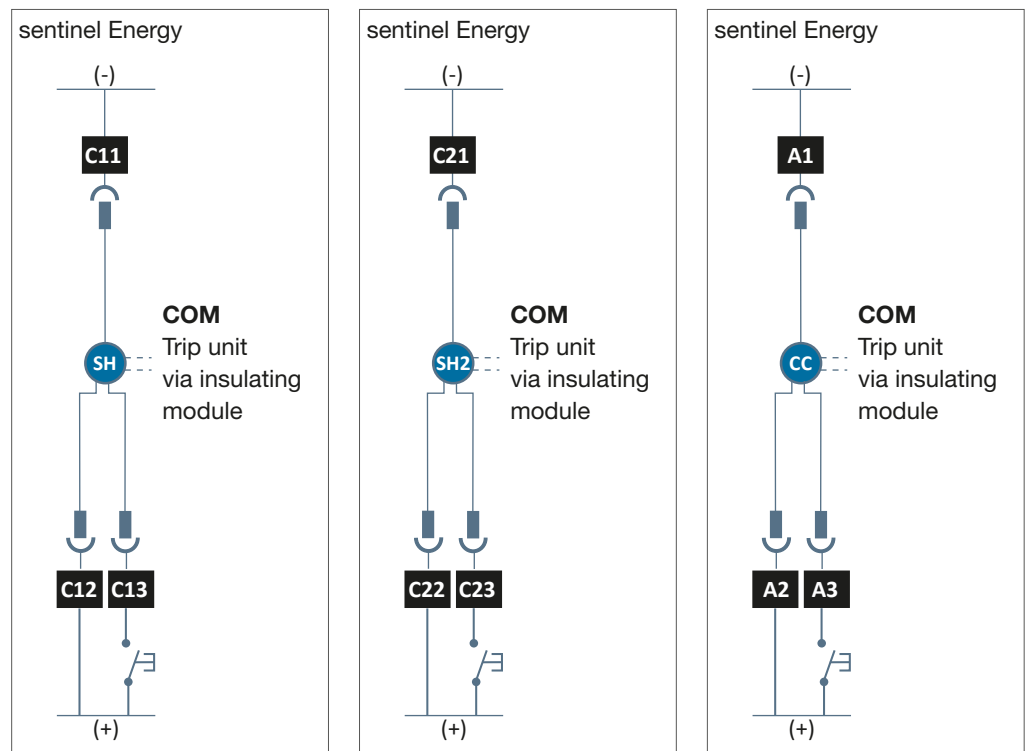

**Special case of SH shunt trip coils and/or DC closing coils at 380-480V AC:**

- Remote control on a circuit-breaker fitted with an Energy trip unit is not possible with a SH shunt trip coil and/or DC closing coil at 380-480V AC.
- Only local control is possible. To achieve this, a jumper of less than 10 cm must be fitted as close as possible to the terminal block between Cx2 and Cx3 (SH or SH2 shunt trip coil) and/or A2 and A3 (DC closing coil).

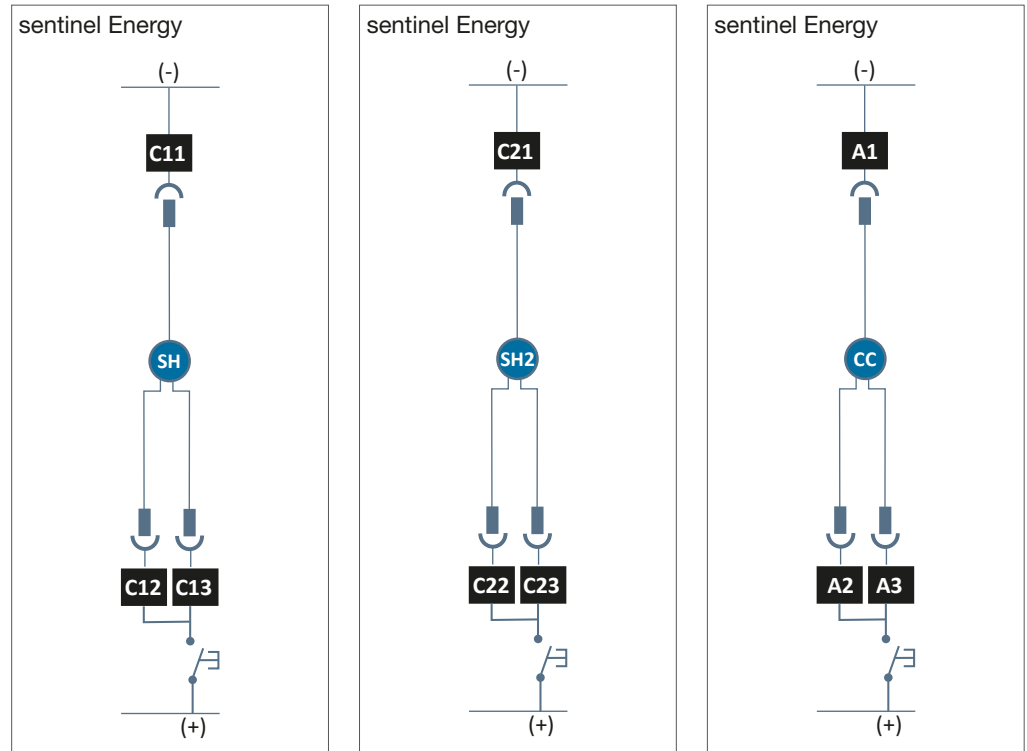

Accessories

**UVTC Time Delay controller for undervoltage release coil**



The UVTC time delay controller allows the tripping of the UV undervoltage release coil to be delayed in order to deal with a transient voltage drop of less than 0.5 seconds. It can be mounted on a DIN rail.

The time delay can be set to OFF - 0.5 - 1.0 - 1.5 - 2.0 - 2.5 - 3 seconds.

**Electrical characteristics of UVTC undervoltage release coil**

Rated voltage (Vn)	
DC (V)	AC (V)
	24-30
	48-60
	200-250
	380-480

## MO charging motor

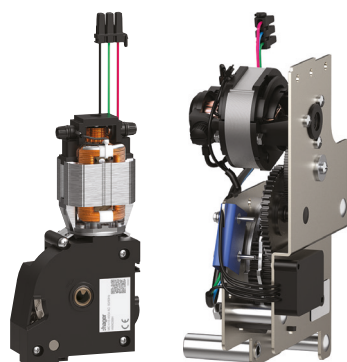

HW1 motor

HW2 / HW4 / HW6 motor

The charging motor is used to automatically recharge the closing spring. Using the motor avoids manual charging of the spring and ensures that the spring is always kept in charged condition during normal operation.

If the motor's power supply is unavailable or the voltage drops, the spring can be charged manually using the charging handle on the circuit breaker.

### Electrical characteristics of the HW1 motors

<b>Operating voltage (AC)</b>	24 V	48-60 V	100-130 V	200-250 V	380-400 V	415-450 V
Frequency	50/60 Hz					
Operating range	85 to 110% Vn					
Rated current / max. peak (A)	9.6 / 25	4.8 / 12.5	2 / 5.2	1 / 2.7	0.6 / 1.5	0.5 / 1.4
Start-up activation (A)	2 to 3 In for 0.1 s					
Maximum arming time (s)	8	6	4		3	
Active power (VA)	230					
Operating frequency	maximum 3 cycles per minute					
Life cycle*	15,000					

<b>Operating voltage (DC)</b>	24 V	48-60V	100-130 V	200-250 V		
Operating range	85 to 110% Vn					
Rated current / max. peak (A)	9.6 / 25	4.8 / 12.5	2 / 5.2		1 / 2.7	
Start-up activation (A)	2 to 3 In for 0.1 s					
Maximum arming time (s)	8	6	4			
Active power (W)	230					
Operating frequency	maximum 3 cycles per minute					
Life cycle*	15,000					

### Electrical characteristics of the HW2, HW4 and HW6 motors

<b>Operating voltage (AC)</b>	24 V	48-60 V	100-130 V	200-250 V	380-400 V	415-450 V
Frequency	50/60 Hz					
Operating range	85 to 110% Vn					
Rated current / max. peak (A)	8.2 / 20	4.2 / 12	2.3 / 5.1	1 / 3.1	0.6 / 1.5	0.5 / 1.4
Start-up activation (A)	2 to 3 In for 0.1 s					
Maximum arming time (s)	8	7	6	5		
Active power (VA)	196.8	201.6	299	250	240	220
Operating frequency	maximum 3 cycles per minute					
Life cycle*	12500 (HW2) / 10000 (HW4) / 8500 (HW6)					

<b>Operating voltage (DC)</b>	24 V	48-60V	100-130 V	200-250 V		
Operating range	85 to 110% Vn					
Rated current / max. peak (A)	8.2 / 20	4.2 / 12	2.3 / 5.1		1 / 3.1	
Start-up activation (A)	2 to 3 In for 0.1 s					
Maximum arming time (s)	8	7	6	5		
Active power (W)	196.8	201.6	299	250		
Operating frequency	maximum 3 cycles per minute					
Life cycle*	12500 (HW2) / 10000 (HW4) / 8500 (HW6)					

\* Test carried out with a frequency of 2 cycles per minute

## Signalling accessories overview

The signalling accessories provide information concerning the status and position of the circuit breaker, the presence of an electrical fault and the number of operations.

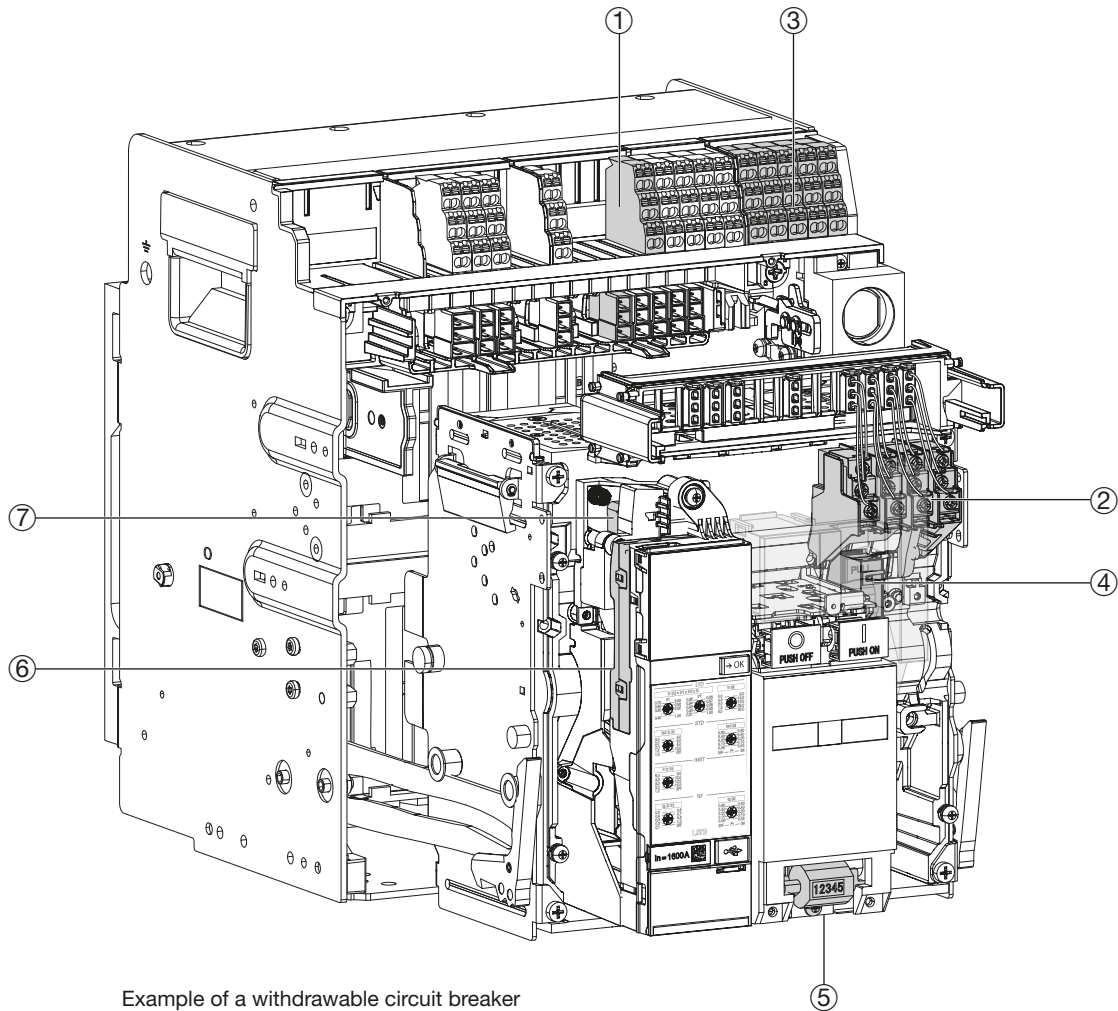

Example of a withdrawable circuit breaker

- |   |   |          |
|---|---|----------|
| ① | TB terminal block connection                        | page 87  |
| ② | AX auxiliary contact                                | page 96  |
| ③ | PS position contact (only for withdrawable version) | page 99  |
| ④ | RTC ready-to-close-contact                          | page 100 |
| ⑤ | CYC cycle counter                                   | page 101 |
| ⑥ | OAC output alarm contacts module                    | page 98  |
| ⑦ | FS fault trip contact                               | page 97  |

### AX auxiliary contact

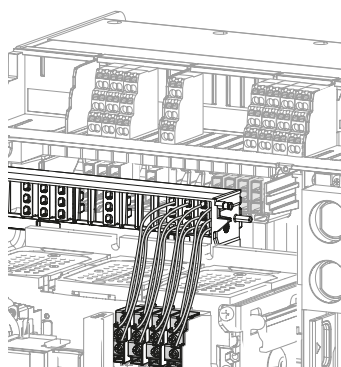
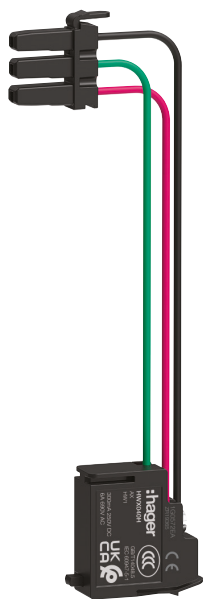

The AX auxiliary contacts are used for remote signalling of the open or closed status of the circuit breaker power contacts or to perform an electrical locking.

AX auxiliary contacts are included with the circuit breaker as standard, depending on the range:

	Integrated	Additional	Total
<b>HW1</b>	4 AX	-	4 AX
<b>HW2</b>	4 AX	6 AX	10 AX
<b>HW4 / HW6</b>	6 AX	6 AX	12 AX

For HW1, the mounted contacts can be "standard" or "low level" (see table at the bottom of the page) and are defined during the product configuration.

For HW2, HW4 and HW6, "standard" contacts are fitted by default. The "low level" type can be fitted as an optional accessory and is defined during product configuration.

### AX auxiliary contact marking

AX1	AX2	AX3	AX4
012	022	032	042
014	024	034	044
011	021	031	041

AX10	AX11	AX12/vN
102	112	122 <sub>vN</sub>
104	114	124
101	111	121

### Connection diagram

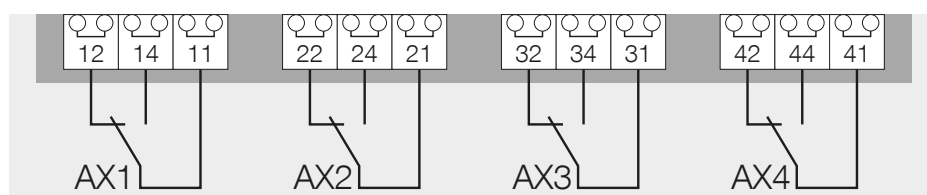

AX auxiliary contact positions

### AX auxiliary contact characteristics

Type			Standard			Low level		
Minimum load			24 V 100 mA			15 V 2 mA		
Breaking capacity (A)	Usage <sup>(1)</sup>	Ue (V)	AC12	AC13	AC15	AC12	AC13	AC15
	V AC	127	6.0	5.0	5.0	5.0	2.5	2.5
		240	6.0	4.0	4.0	5.0	2.0	2
		380	6.0	4.0	2.0	5.0	1.5	1.5
		440	6.0	3.0	2.0	5.0	1.5	1.5
		480	6.0	2.0	1.5	5.0	1	-
		690	6.0	1.0	0.1	5.0	-	-
	Usage <sup>(1)</sup>	Ue (V)	DC12	DC13	DC14	DC12	DC13	DC14
	V DC	24	2.5	2.5	1	5.0	2.5	1
		48	2.5	1.2	0.2	2.5	1.2	0.2
125		0.5	0.4	0.05	0.5	0.35	0.05	
250		0.3	0.05	0.03	0.3	0.05	0.03	

(1) According to standard IEC 60947-5-1

**FS fault trip contact**

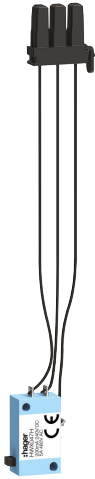

The FS fault trip contact is used to signal the opening of the circuit breaker following a trip due to an electrical fault.

The causes for the tripping can be of different types:

- overload,
- short circuit,
- earth fault GF,
- critical system alarm.

The contact returns to its rest position when the circuit breaker is reset using the "RESET" button on the front of the circuit breaker.



The "RESET" re-arm button resets the FS fault trip contact.

An FS contact is built into all circuit breakers.



The maximum number of FS contacts for HW1 circuit breakers is two unless the RTC ready-to-close contact is installed. For HW2, HW4 and HW6, two additional FS contacts (FS2 and FS3) can be installed. If an FS3 contact is installed and wired, the RTC ready-to-close contact cannot be wired.

**FS fault trip contact marking**

FS	RTC/FS2
F12	R2 <small>F22</small>
F14	R4 <small>F24</small>
F11	R1 <small>F21</small>

For HW1

FS	FS2	RTC/FS3
F12	F22	R2 <small>F32</small>
F14	F24	R4 <small>F34</small>
F11	F21	R1 <small>F31</small>

For HW2, HW4 and HW6

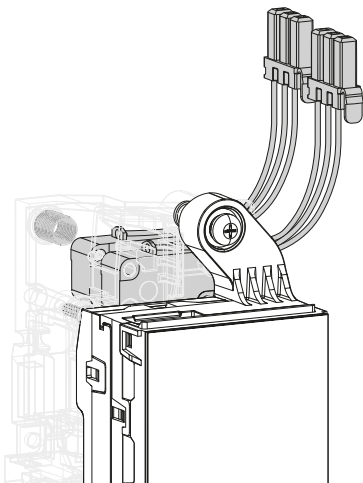

FS fault trip contact space

**Connection diagram**

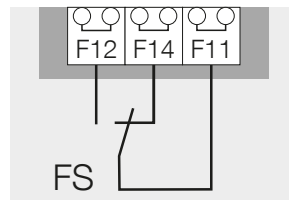

**Characteristics of the FS fault trip contact**

Minimum load		15 V 2 mA			
Breaking capacity (A)	Usage <sup>(1)</sup>	Ue (V)	AC12	AC13	AC15
	V AC	127	5.0	5.0	5.0
		240	5.0	5.0	4.0
		380	5.0	5.0	3.0
		440	5.0	5.0	3.0
		480	5.0	2.0	2.0
		690	-	-	-
	Usage <sup>(1)</sup>	Ue (V)	DC12	DC13	DC14
	V DC	24	5.0	2.5	1
		48	2.5	1.0	0.2
125		0.4	0.2	0.02	
240		0.2	0.1	0.01	

(1) According to standard IEC 60947-5-1

## OAC output alarm contacts module



The OAC output contacts module can be used to signal an alarm, trip or operational event.

The OAC contacts are assigned permanently to the following events on a circuit breaker equipped with the sentinel trip unit:

- LTD tripping,
- STD/INST/MCR tripping,
- GF tripping,
- overload pre-alarm,
- tripping due to a critical system alarm.

The assignment of OAC contacts is programmable on a circuit breaker equipped with a sentinel Energy trip unit.

Each OAC contact cannot be reassigned to a distinct trip, alarm or operational event, chosen from a predefined list offering more than 40 options.

The OAC contacts with a sentinel Energy trip unit are assigned by default to the following events:

- LTD tripping,
- grouped alarm (configured to STD, INST or MCR tripping),
- GF tripping,
- overload pre-alarm,
- tripping due to a critical system alarm.



For correct operation an external 24 V CC SELV power supply must be connected to the circuit breaker.

### Output alarm contact marking

OAC			
LTD	DO1	GF	DO3
STD/INST	DO2	PTA	DO4
DOC		HWF	DO5

LTD	tripping of the Long Time Delay protection
STD/INST or S/I	tripping of the Short Time Delay, Instantaneous or MCR protection
DOC	common
GF	tripping of the GF earth fault protection
PTA	Overload pre-alarm activation
HWF	tripping due to a critical system alarm

### Connection diagram

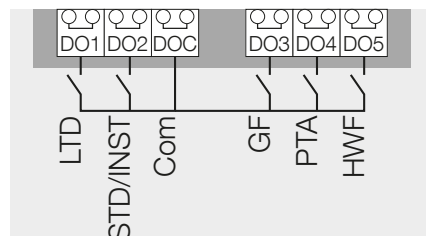

Characteristics of the contacts:

250 V AC - 2 A - AC1  
30 V DC - 2 A - DC1



**PS position contact (only for withdrawable version)**

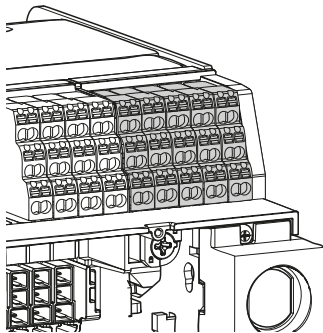

PS position contact slots

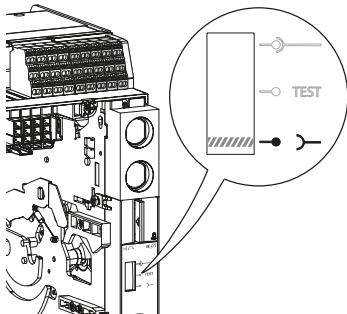

Position indicator of the moving part (circuit breaker) in its chassis

This contact indicates one of the three positions of the circuit breaker inside the chassis according to its position on the terminal block support. It is available in the standard or low level version:

Location of the contact on the terminal block support	Indicates the position	Status of the power circuits	Status of the auxiliary circuits
D1 / D2 / D3	Disconnected	Disconnected	Disconnected
T1 / T2	Test	Disconnected	Connected
C1 / C2 / C3	Connected	Connected	Connected

Position	Max. number of contacts		
	HW1	HW2	HW4 / HW6
D (Disconnected)	2	2	3
T (Test)	1	1	2
C (Connected)	2	2	3

**Marking of PS position contacts**

D1	D2	D3	T1	T2	C1	C2	C3
D12	D22	D32	T12	T22	C12	C22	C32
D14	D24	D34	T14	T24	C14	C24	C34
D11	D21	D31	T11	T21	C11	C21	C31

**Connection diagram**

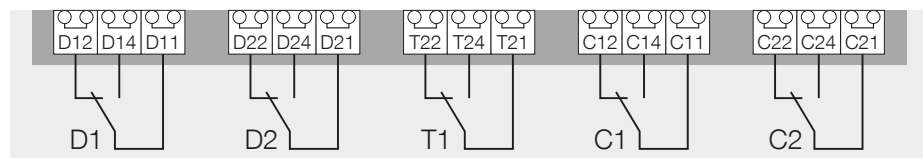

**PS position contact characteristics**

Type			Standard contact			Low level contact		
Minimum load			24 V 100 mA			15 V 2 mA		
Breaking capacity (A)	Usage <sup>(1)</sup> V AC	Ue (V)	AC12	AC13	AC15	AC12	AC13	AC15
		127	8.0	5.0	5.0	5.0	2.5	2.5
		240	8.0	4.0	4.0	5.0	2.0	2
		380	8.0	4.0	2.0	5.0	1.5	1.5
		440	8.0	3.0	2.0	5.0	1.5	1.5
		480	8.0	2.0	1.5	5.0	1	-
	690	6.0	1.0	0.1	5.0	-	-	
	Usage <sup>(1)</sup> V DC	Ue (V)	DC12	DC13	DC14	DC12	DC13	DC14
		24	2.5	2.5	1	5.0	2.5	1
		48	2.5	1.2	0.2	5.0	1.2	0.2
		125	0.8	0.4	0.05	0.8	0.35	0.05
		250	0.3	0.05	0.03	0.3	0.05	0.03

(1) According to standard IEC 60947-5-1

### RTC ready-to-close-contact

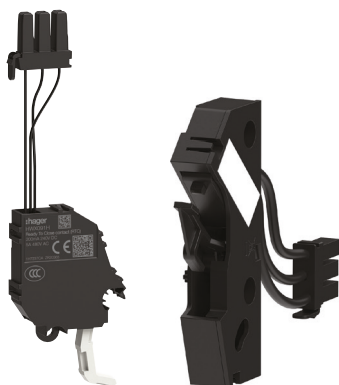

RTC Ready-to-Close contact HW1

RTC Ready-to-Close contact HW2, HW4 and HW6

The RTC ready to close contact indicates that the circuit breaker has verified the closing conditions and that it is ready to receive the closing command.

The contact changes status when all of these conditions are met:

- the circuit breaker is in open status,
- the status display of the closing spring shows it is in the charged condition,
- the UV undervoltage release coil is supplied (see chapter: Control accessories / UV undervoltage release coil),
- the SH shunt trip coil is not energised (see chapter: Control accessories / SH shunt trip coil),
- the circuit breaker is in connected position,
- the circuit breaker is not locked in open status by a padlock or key,
- the circuit breaker is not interlocked with a second circuit breaker,
- the "RESET" re-arm button is pressed.

The circuit breaker can now be closed manually or remotely using a closing coil.

**i** For HW1, if the ready-to-close RTC contact is fitted, the second FS fault trip contact cannot be fitted; for HW2, HW4 and HW6, if the ready-to-close RTC contact is fitted, the third FS3 fault trip contact cannot be fitted.

The "Ready to close" information is also visible on the front of the circuit breaker:

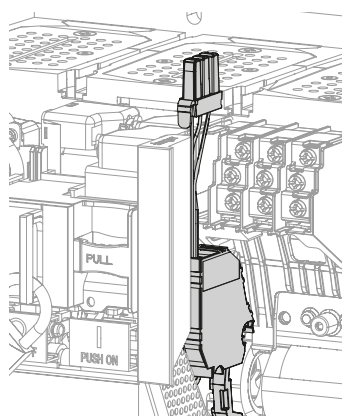

RTC ready-to-close-contact

#### RTC ready-to-close contact marking

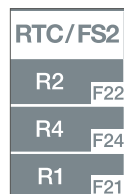

For HW1

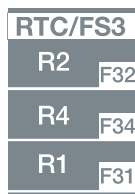

For HW2, HW4 and HW6

#### Connection diagram

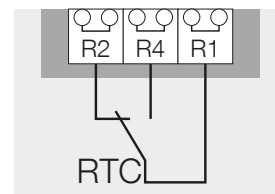

### Characteristics of the RTC ready-to-close-contact

Minimum load		15 V 2 mA			
Breaking capacity (A)	Usage <sup>(1)</sup>	Ue (V)	AC12	AC13	AC15
	V AC	127	5.0	5.0	5.0
		240	5.0	5.0	4.0
		380	5.0	5.0	3.0
		440	5.0	5.0	3.0
		480	5.0	2.0	2.0
		690	-	-	-
	Usage <sup>(1)</sup>	Ue (V)	DC12	DC13	DC14
	V DC	24	5.0	2.5	1
		48	2.5	1.0	0.2
125		0.4	0.2	0.02	
240		0.2	0.1	0.01	

(1) According to standard IEC 60947-5-1

**CYC cycle counter**



The cycle counter indicates the circuit breaker's total number of electrical and mechanical operation cycles. The counter readings can be used as indicators for maintenance or inspection.

The cycle counter is installed on the front side of the circuit breaker at the bottom section.

## Locking and interlocking accessories overview

The locking and interlocking accessories are safety devices designed to protect users as well as the distribution system. They:

- give access to the circuit breaker only to authorised and approved operators.
- limit the risks of errors during operation.

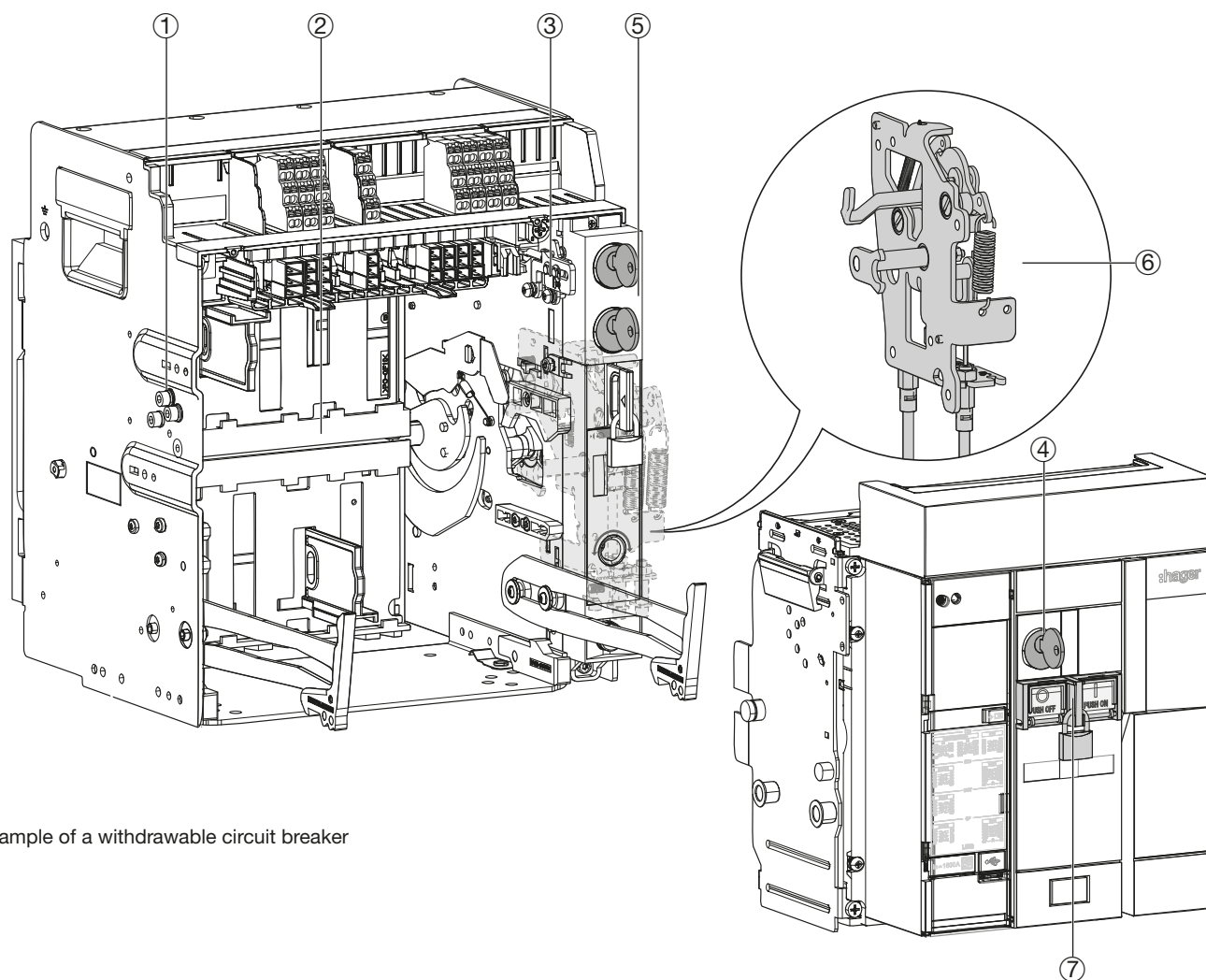

Example of a withdrawable circuit breaker

- |   |  |          |
|---|--|----------|
| ① | WIP wrong insertion preventer for withdrawable circuit breaker | page 103 |
| ② | Safety shutters  | page 104 |
| ③ | RI open door racking interlock                                 | page 104 |
| ④ | Locking the circuit breaker in OFF by OLK key lock             | page 105 |
| ⑤ | Locking the position of the circuit breaker in its CL chassis  | page 107 |
| ⑥ | MI mechanical interlock  | page 108 |
| ⑦ | PBC push button cover  | page 110 |

**WIP wrong insertion preventer for withdrawable circuit breaker**



Wrong insertion preventer WIP HW1  
Wrong insertion preventer WIP HW2, HW4 and HW6

The wrong insertion preventer is a mechanical device used to carry out a predetermined pairing of the circuit breaker with its chassis.

This system must be installed on the chassis and the moving part of the device. Up to 10 different combinations can be made.

The combination chosen on the chassis must correspond to the combination of the circuit breaker in order for the 2 parts to be compatible.

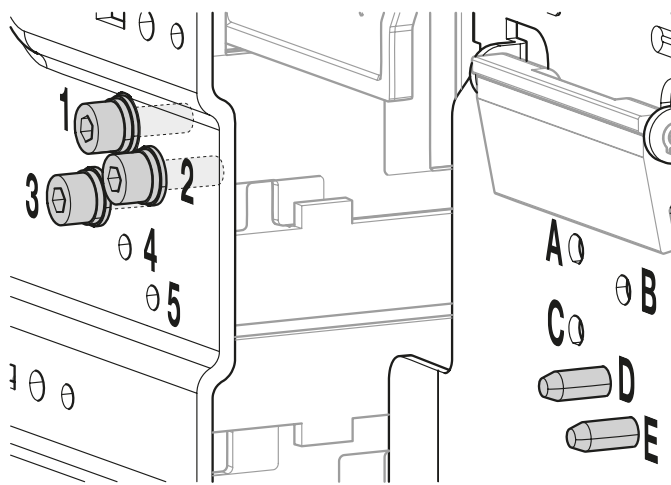

Example of installation with the combinations 123 for the chassis and DE for the HW1 circuit breaker.

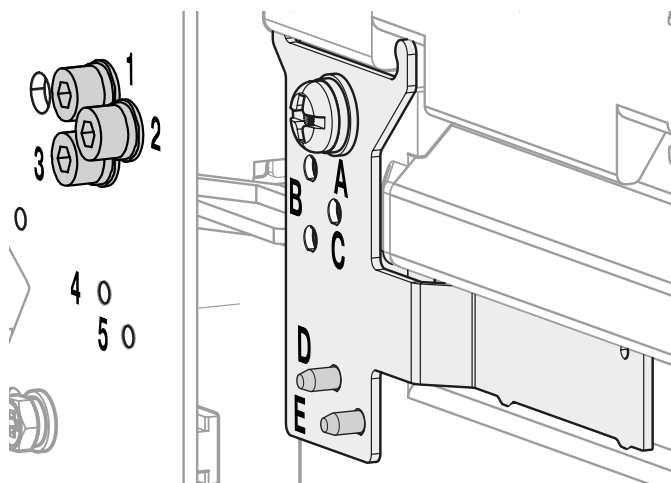

Example of installation with the combinations 123 for the chassis and DE for the HW2, HW4 and HW6 circuit breakers

**List of combinations**

Chassis	Circuit breaker
123	DE
124	CE
125	CD
134	BE
135	BD
145	BC
234	AE
235	AD
245	AC
345	AB

Accessories

## Safety shutters

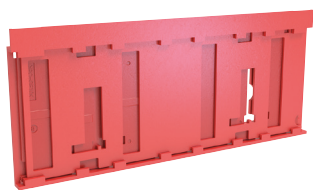

HW1 safety shutters



HW2, HW4 and HW6 safety shutters

- The safety shutters cover the contacts of the main circuit in the chassis when the circuit breaker is in either disconnected or test position. In this way it precludes accidental access to the clamps. The IP20 protection class is now guaranteed.
  - For HW1, the upper and lower shutters operate independently and can be padlocked separately.
  - For HW2, HW4 and HW6, the upper and lower shutters operate together and can be padlocked together.
- The upper and lower shutters operate independently and can be padlocked separately. The padlocks block the safety shutters in the closed position and prevent a product being racked in. Up to three padlocks can be fitted per shutter. 1 to 3 Ø5-Ø8 mm padlocks not included.

The shutters are factory fitted on each hw+ chassis.

## RI open door racking interlock

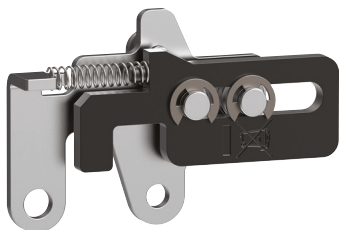

RI HW1 open door racking interlock

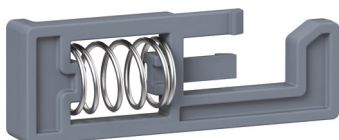

RI HW2, HW4 and HW6 open door racking interlock

This device prevents the racking handle being inserted into the place to insert/withdraw the racking handle when the door of the distribution board is open.

For that reason the rack's input/output operation may only be performed once the distribution board's door has been closed, ensuring complete safety for the operating staff.

### Locking of the circuit breaker in OFF by OLP padlock or OLK key lock

These locking devices are used to lock the OFF push button in pressed condition in order to prevent the circuit breaker from closing.



Padlocking

#### OLP padlock locking device as an accessory

The adaptation accessory for OLP padlock locking can be mounted after delivery. To lock the circuit breaker in the open state by means of a padlock, keep the circuit breaker OFF push button pressed and then pull the tab to install the padlocks:  
1 to 3 Ø5-Ø8 mm padlocks not included.



Locking with key locks

#### Locking device with OLK key lock as an accessory

The adaptation accessory for the OLK key lock can be mounted on the front of the circuit breaker. To lock the circuit breaker in the open state using a key lock, keep the circuit breaker OFF push button pressed and then turn the lock key till it is vertical. The key can be removed.

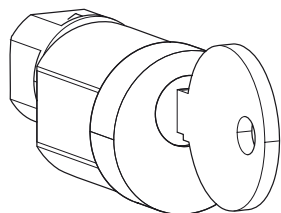

Ronis type lock

#### Compatible locks

Description	Characteristics	Key compatible with the type of lock
Ronis type key lock	type 1 – K1L1/L4	1, 4
	type 2 – K2L2/L4/L5	2, 4, 5
	type 3 – K3L3/L5	3, 5
	type 4 – K4L4	4
	type 5 – K5L5	5

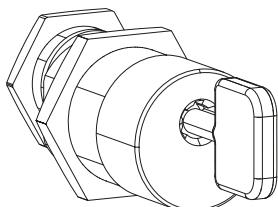

Profalux type lock

#### Description

Profalux type key lock (not available in our offer)

#### ATTENTION

Once the push-button is locked in the PUSH ON position, the circuit breaker cannot be closed, either mechanically or electrically.

### Example of key interlocking between 3 circuit breakers:

It is possible to achieve an interlocking between three circuit breakers using a combination of locks mounted on each of the products. This device is recommended for a busbar coupling application. Only two circuit breakers can be supplied with two captive keys in ON. The third circuit breaker cannot be closed because it is locked in OFF and is keyless.

- Air circuit breaker (ACB) 3 is locked in OFF

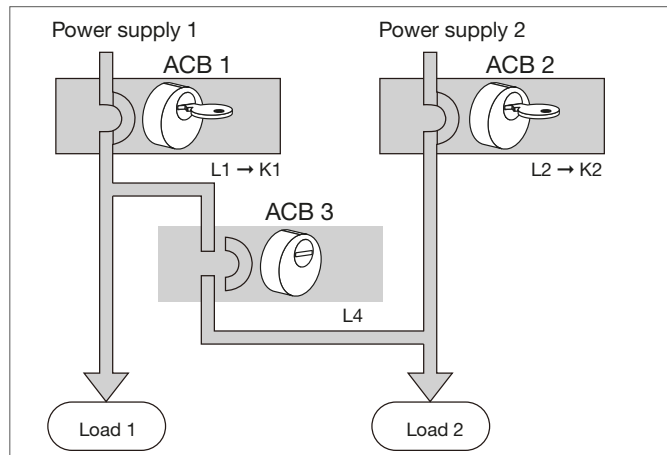

ACB 3 cannot be closed

#### Step 1:

- ACB 3 is locked in OFF and cannot be closed.
- ACB 1 and ACB 2 are in ON with the two captive keys in this position.

L1: lock type 1  
L2: lock type 2  
L4: lock type 4  
K1: first key  
K2: second key

- Air circuit breaker (ACB) 2 is locked in OFF

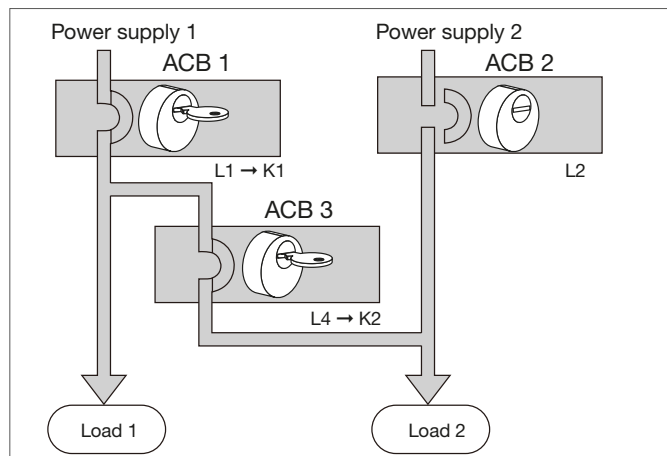

ACB 2 cannot be closed

#### Step 2:

First open one of the two closed circuit breakers (here ACB 2) in order to remove the key and close ACB 3.

- Air circuit breaker (ACB) 1 is locked in OFF

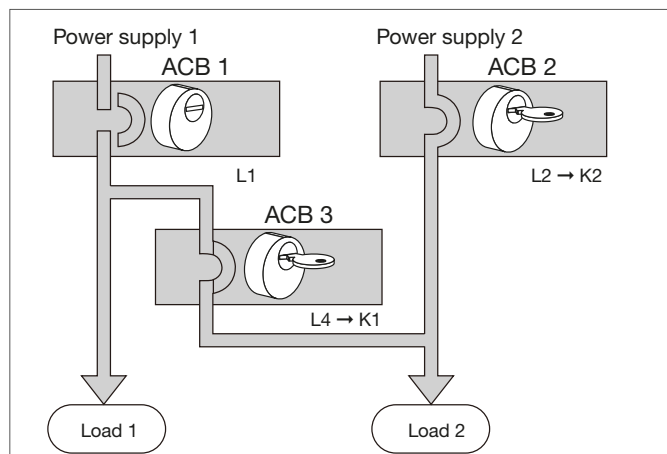

ACB 1 cannot be closed

#### Step 3:

First open ACB 1 in order to remove the key and close ACB 2.



### Locking the position of the circuit breaker in its CL chassis

This device is used to lock the circuit breaker in its chassis in disconnected, test or connected position and prevent the insertion of the rack in/rack out handle.

Locking can be by means of:

- integrated locking device, by pulling on the padlock latch and position acknowledgement tab, installation of one to three Ø5-Ø8 mm padlocks (not provided),
- one or two key locks, available as an option.

#### Locking device with key locks, available as an option

There are two possibilities for locking with keys:

- a single lock fitted in such a way as to achieve a simple locking of the circuit breaker,
- two different locks fitted in such a way as to achieve a double locking of the position, thereby guaranteeing a high level of security.

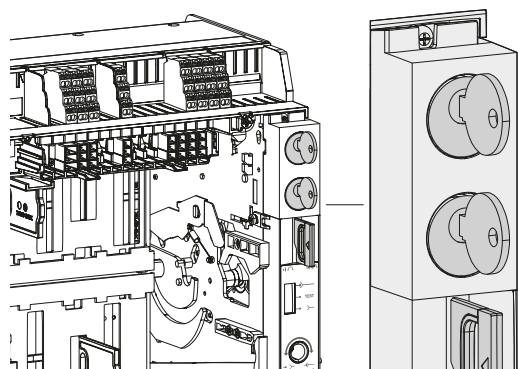

2 key locks mounted on the locking device  
1 padlocking and position acknowledgement tab for HW1 circuit breaker

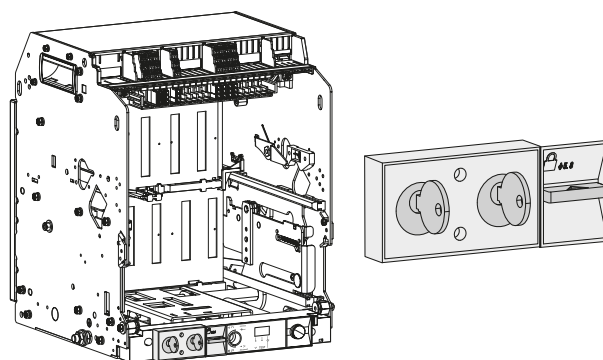

2 key locks mounted on the locking device  
1 padlocking and position acknowledgement tab for HW2 and HW4 circuit breaker.

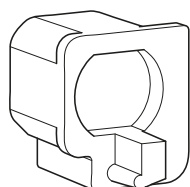

Adapter kit

#### Description

Adapter kit for Ronis or Profalux type locks

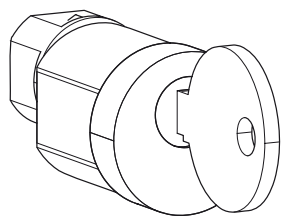

Ronis type lock

#### Compatible locks

Description	Characteristics	Key compatible with the type of lock
Ronis type key lock	type 1 – K1L1/L4	1, 4
	type 2 – K2L2/L4/L5	2, 4, 5
	type 3 – K3L3/L5	3, 5
	type 4 – K4L4	4
	type 5 – K5L5	5

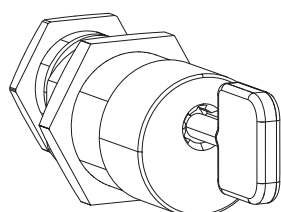

Profalux type lock

#### Description

Profalux type key lock (not available in our offer)

## MI mechanical interlock

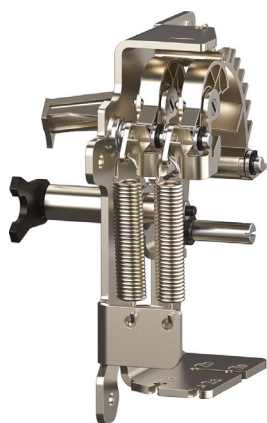

Mechanical interlocking by cable makes it possible for 2 or 3 hw+ circuit breakers to be interlocked with each other.

The cable interlocking system provides a higher degree of flexibility when it comes to integration into distribution systems:

- All combinations of circuit breakers (3P, 4P, Fixed, withdrawable) are possible.
- Circuit breakers can be installed one above the other or side by side.
- Several cable lengths are available so as to be compatible with any type of installation.



For any mechanical interlocking installation, the following must be installed on the circuit breaker:

- A CYC cycle counter
- A PBC push button cover.

Possibility of mechanical interlocking by cable

Vertical

Horizontal

2 circuit breakers

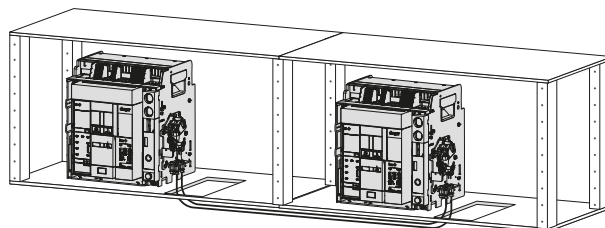
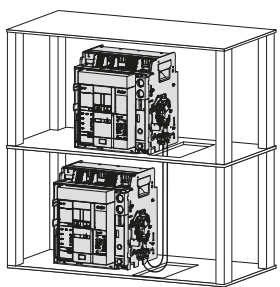

### Types of interlock:

Diagram	Type	Locking logic	Description	Size																										
				HW1	HW2	HW4 / HW6																								
	2S	<table border="1"> <thead> <tr> <th>ACB 1</th> <th>ACB 2</th> </tr> </thead> <tbody> <tr><td>0</td><td>0</td></tr> <tr><td>1</td><td>0</td></tr> <tr><td>0</td><td>1</td></tr> </tbody> </table>	ACB 1	ACB 2	0	0	1	0	0	1	Only one device out of two can be closed.	X	X	X																
ACB 1	ACB 2																													
0	0																													
1	0																													
0	1																													
	3S	<table border="1"> <thead> <tr> <th>ACB 1</th> <th>ACB 2</th> <th>ACB 3</th> </tr> </thead> <tbody> <tr><td>0</td><td>0</td><td>0</td></tr> <tr><td>1</td><td>0</td><td>0</td></tr> <tr><td>0</td><td>1</td><td>0</td></tr> <tr><td>0</td><td>0</td><td>1</td></tr> </tbody> </table>	ACB 1	ACB 2	ACB 3	0	0	0	1	0	0	0	1	0	0	0	1	Only one device out of three can be closed.	X	X	X									
ACB 1	ACB 2	ACB 3																												
0	0	0																												
1	0	0																												
0	1	0																												
0	0	1																												
	3SX	<table border="1"> <thead> <tr> <th>ACB 1</th> <th>ACB 2</th> <th>ACB 3</th> </tr> </thead> <tbody> <tr><td>0</td><td>0</td><td>0</td></tr> <tr><td>1</td><td>0</td><td>0</td></tr> <tr><td>0</td><td>0</td><td>1</td></tr> <tr><td>1</td><td>0</td><td>1</td></tr> <tr><td>0</td><td>1</td><td>0</td></tr> </tbody> </table>	ACB 1	ACB 2	ACB 3	0	0	0	1	0	0	0	0	1	1	0	1	0	1	0	Allows two devices to be closed if the third is open. The latter can only be closed if the other two are open.	X	X	X						
ACB 1	ACB 2	ACB 3																												
0	0	0																												
1	0	0																												
0	0	1																												
1	0	1																												
0	1	0																												
	3C	<table border="1"> <thead> <tr> <th>ACB 1</th> <th>ACB 2</th> <th>ACB 3</th> </tr> </thead> <tbody> <tr><td>0</td><td>0</td><td>0</td></tr> <tr><td>1</td><td>0</td><td>0</td></tr> <tr><td>0</td><td>1</td><td>0</td></tr> <tr><td>0</td><td>0</td><td>1</td></tr> <tr><td>0</td><td>1</td><td>1</td></tr> <tr><td>1</td><td>1</td><td>0</td></tr> <tr><td>1</td><td>0</td><td>1</td></tr> </tbody> </table>	ACB 1	ACB 2	ACB 3	0	0	0	1	0	0	0	1	0	0	0	1	0	1	1	1	1	0	1	0	1	Two devices out of three can be closed at the same time.	X	X	X
ACB 1	ACB 2	ACB 3																												
0	0	0																												
1	0	0																												
0	1	0																												
0	0	1																												
0	1	1																												
1	1	0																												
1	0	1																												

### Compatible cable lengths:

Types of interlocks	Cable lengths	Size of compatible devices		
		HW1	HW2	HW4 / HW6
2S / 3S / 3SX / 3C	1.5 m	X	X	X
2S / 3S / 3SX / 3C	3 m	X	X	X
2S / 3S / 3SX / 3C	5 m	X	X	X

### PBC push button cover



This cover is a device used to lock out access to the circuit breaker opening (PUSH OFF) and closing (PUSH ON) push buttons.

It prevents any unintentional or unauthorised operations.

It consists of two transparent covers which can be locked with padlocks: (one to three padlocks, not provided), Ø hasp 6 mm maximum.

The push buttons can be blocked independently or jointly.

The covers can be turned to keep the opening push button (PUSH OFF) pressed in, preventing the circuit breaker from closing.

## Overview of the power connection accessories

The connection sockets facilitate the integration of the circuit breaker into distribution systems. Additional accessories simplify connection according to the needs of the installation.

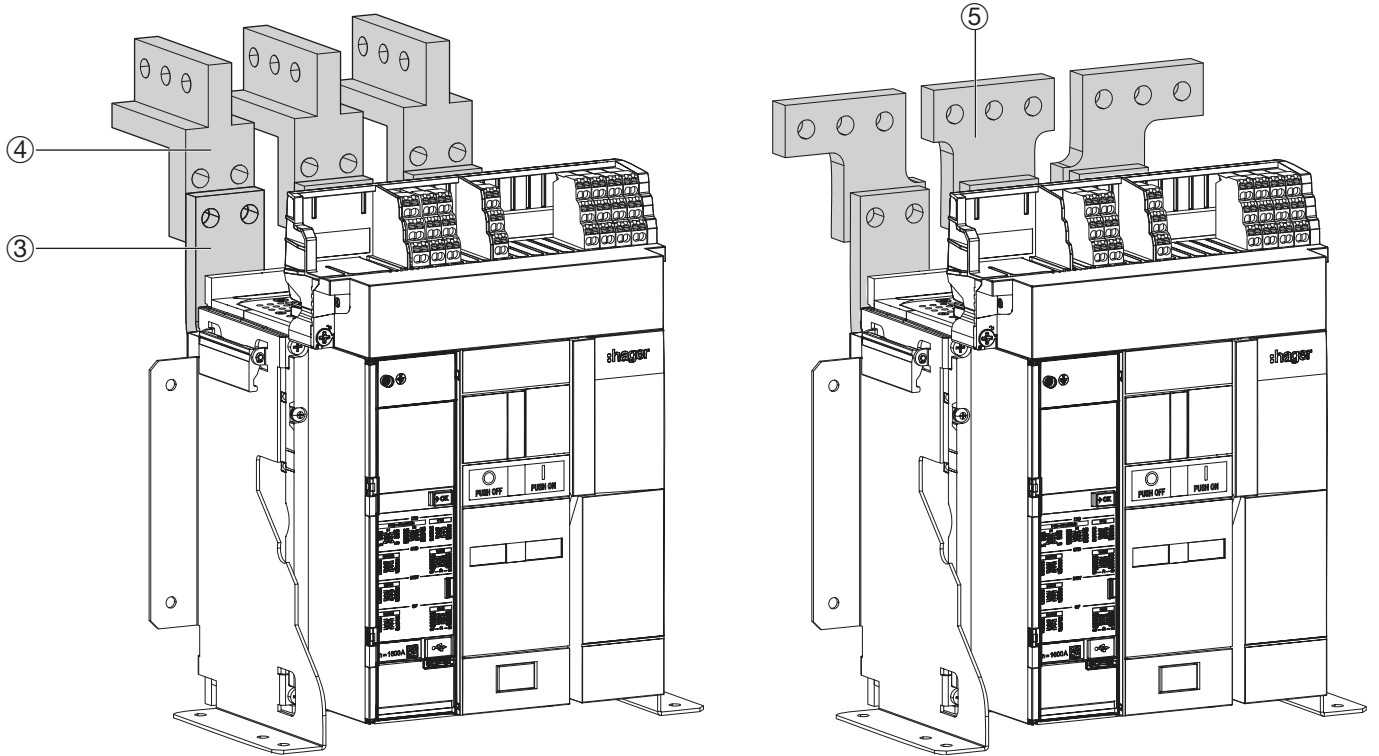

Examples of an HW1 fixed circuit breaker

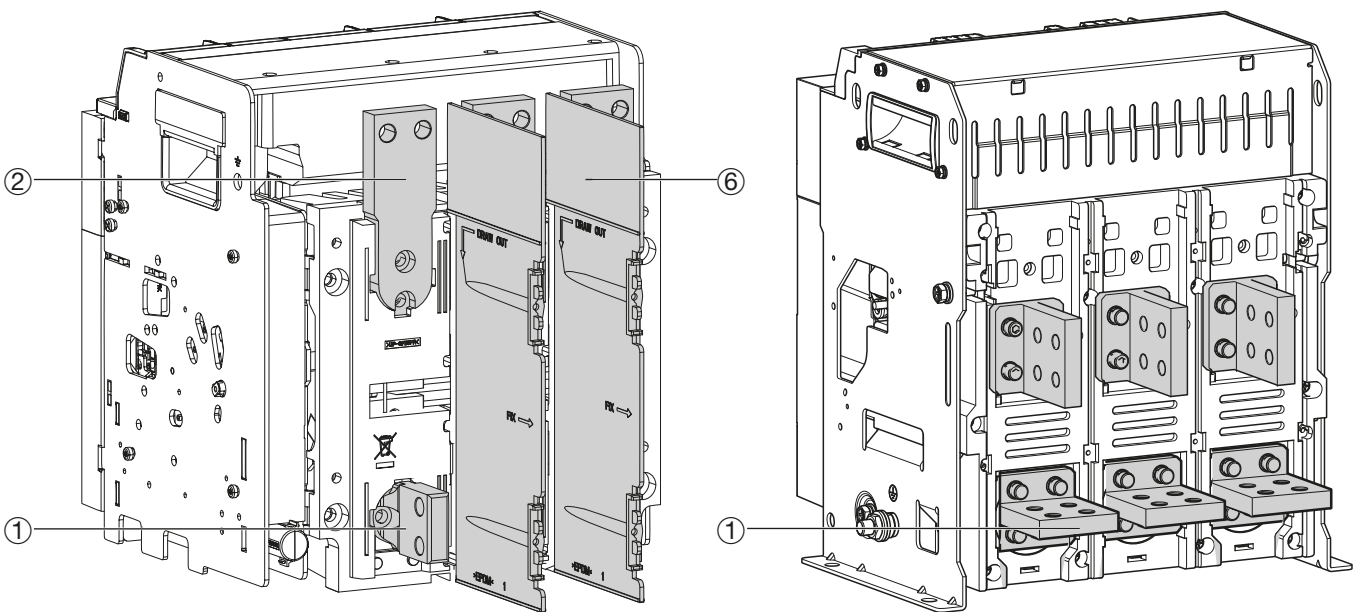

Example of an HW1 withdrawable circuit breaker

Example of an HW2 fixed circuit breaker

- |   |   |          |   |   |          |
|---|---|----------|---|---|----------|
| ① | Rear vertical / horizontal RC HW1 connections | page 113 | ④ | VCA HW1 vertical connectors             | page 116 |
| ② | FC HW1 front sockets for withdrawable version | page 113 | ⑤ | Spreaders SP HW1                        | page 116 |
| ③ | FC HW1 front sockets for fixed version        | page 113 | ⑥ | IB interphase barriers HW1, HW2 and HW4 | page 117 |

**Terminal connections**

There are several types of sockets to connect circuit breakers and chassis to power busbars:

- The rear connections:

Available on fixed and withdrawable circuit breakers.

The rear connections can be easily pivoted to the horizontal or vertical.

- The front connections:

Available on fixed and withdrawable circuit breakers. The upper and lower connections can be equipped with different combinations of sockets.

Depending on the circuit breaker, additional accessories are available to adapt the connection to the busbars (see table below).

**Identical connections at the top and bottom**

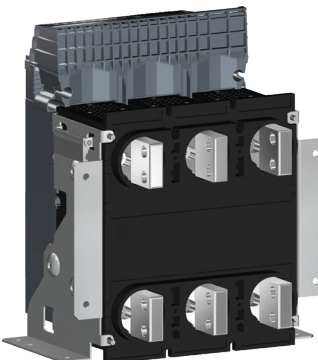
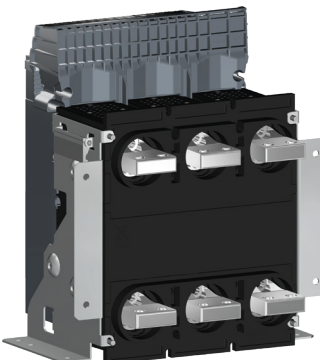
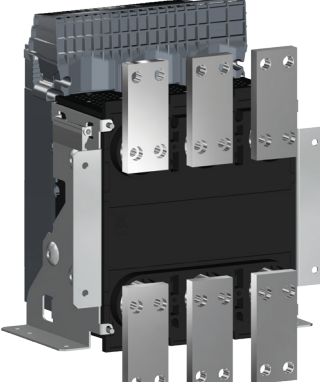
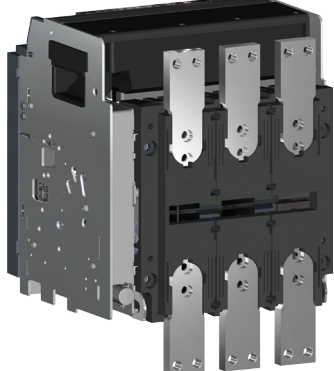
Vertical rear	Horizontal rear	Front (for fixed circuit breaker)	Front (for withdrawable circuit breaker)
			

Sockets can also be combined. See below for some examples:

Vertical rear / Horizontal rear	Horizontal rear / Vertical rear	Horizontal rear / Front	Front / Horizontal rear
Vertical rear / Front	Front / Vertical rear	Long horizontal rear / Horizontal rear	Long front / Long horizontal rear



Rear vertical / horizontal RC HW1 connections

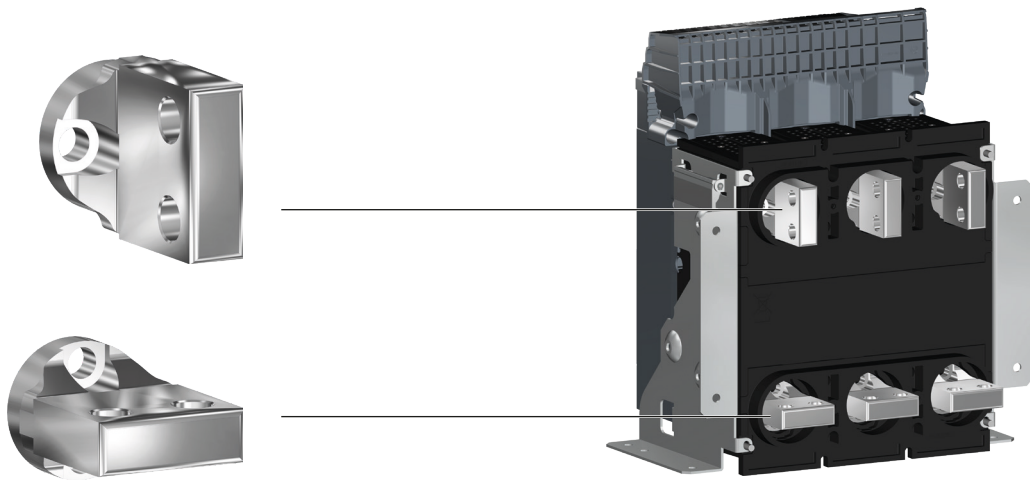

FC HW1 front sockets  
for withdrawable version

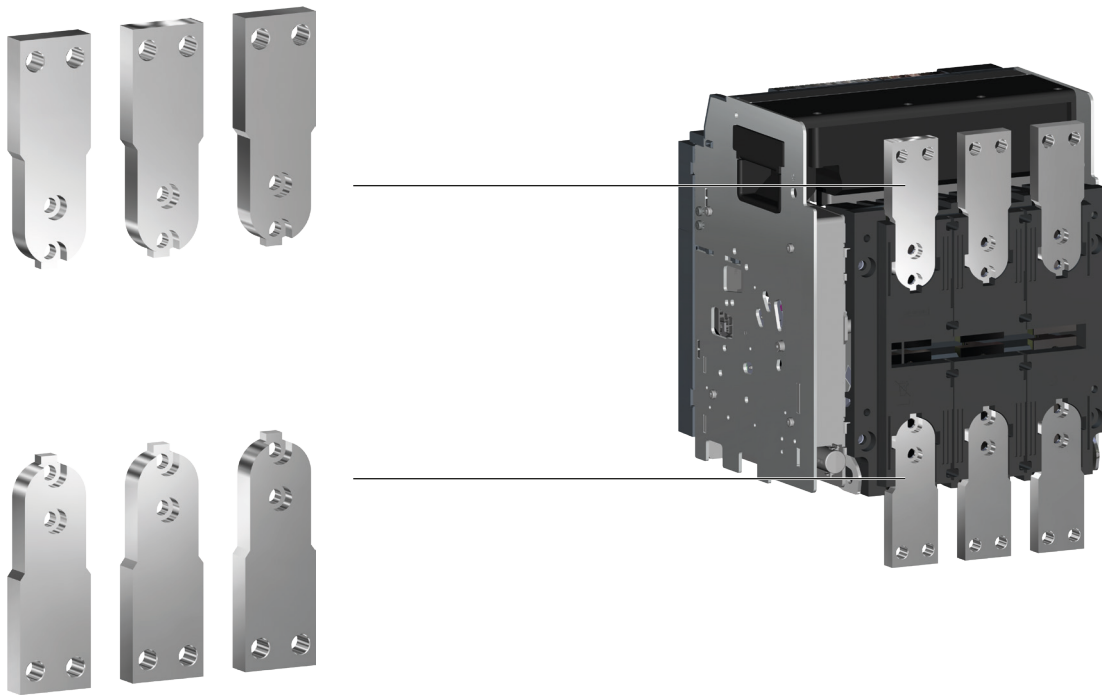

for fixed version

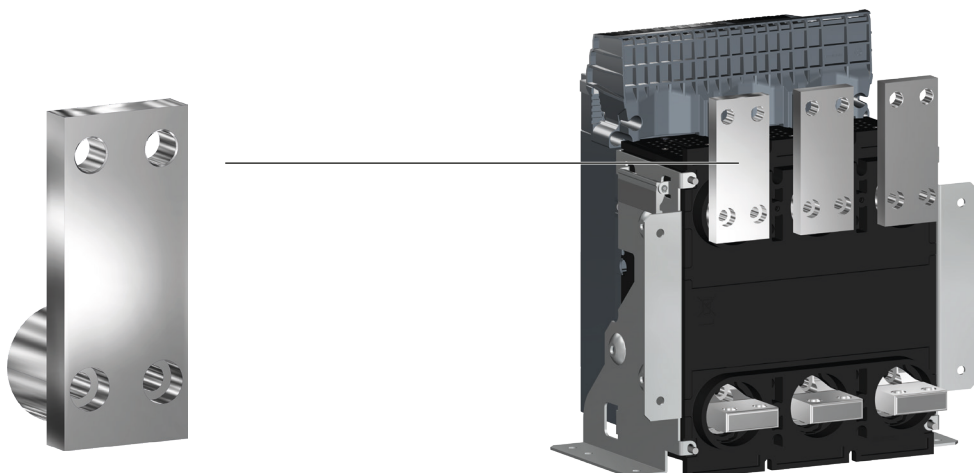

**Rear vertical / horizontal RC HW2 connections  
For withdrawable / fixed version**

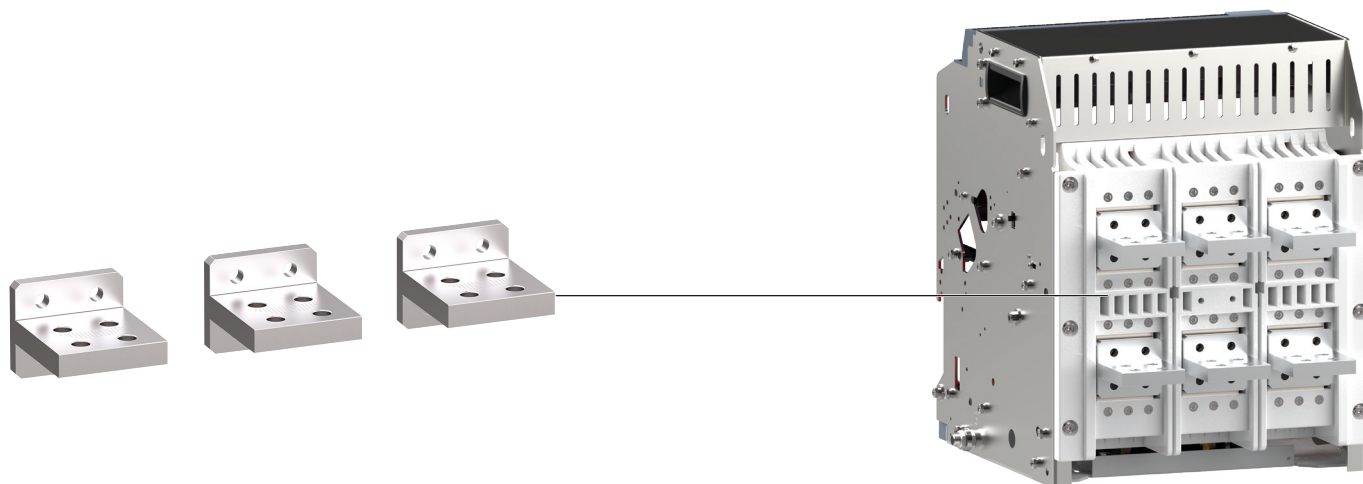

**Rear horizontal RC HW2 connections for Unimes H  
For withdrawable / fixed version**

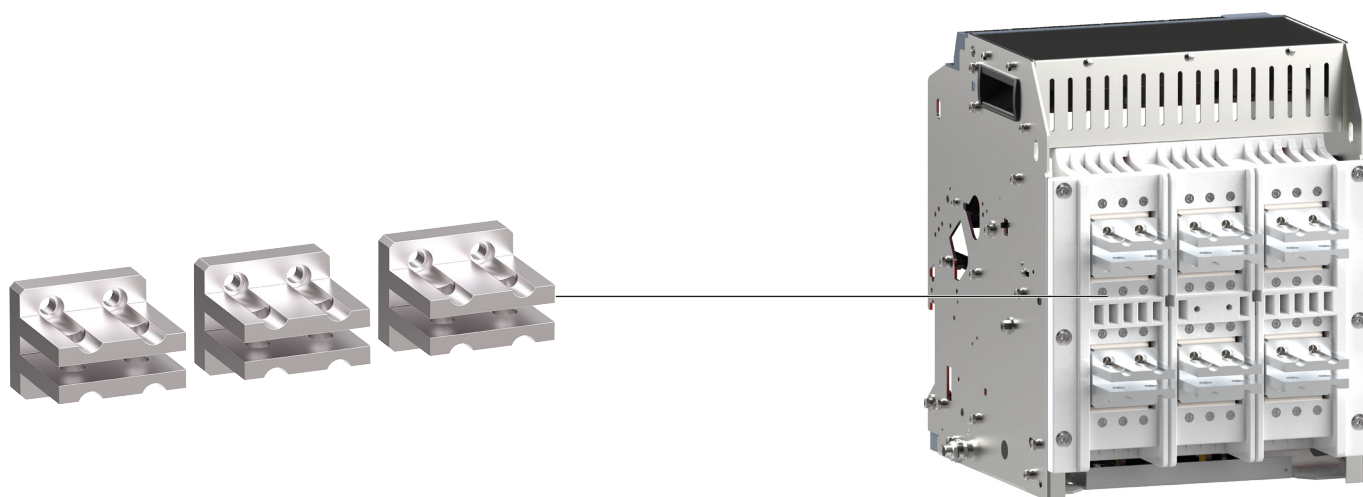

**Rear vertical / horizontal RC HW2 630-1600A 55kA connections  
For withdrawable / fixed version 630-1600 A 55k A**

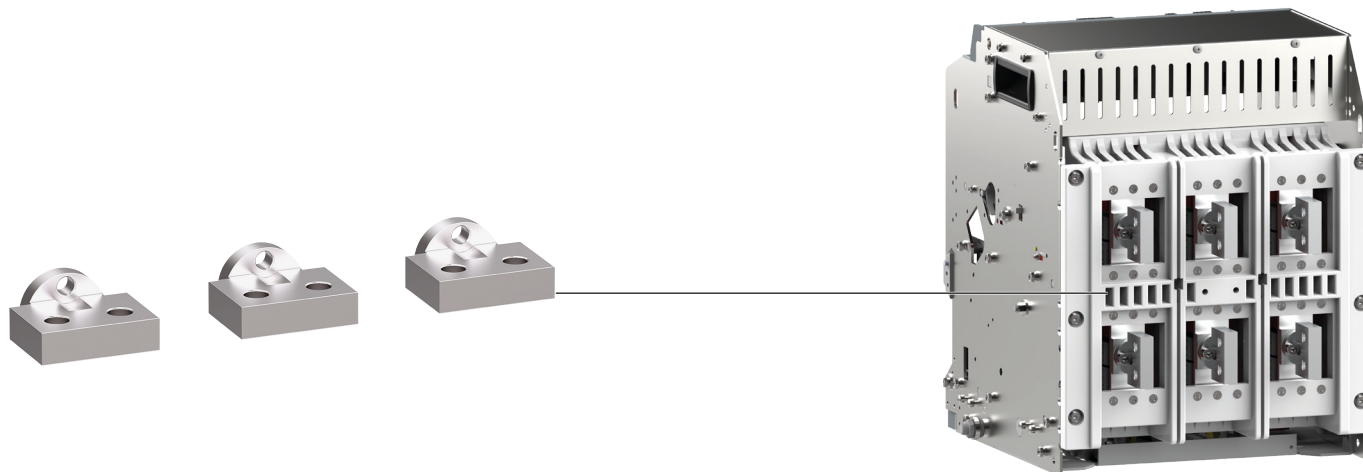



**Rear vertical / horizontal RC HW4 connections**  
For withdrawable / fixed version from 1000 A to 2500 A

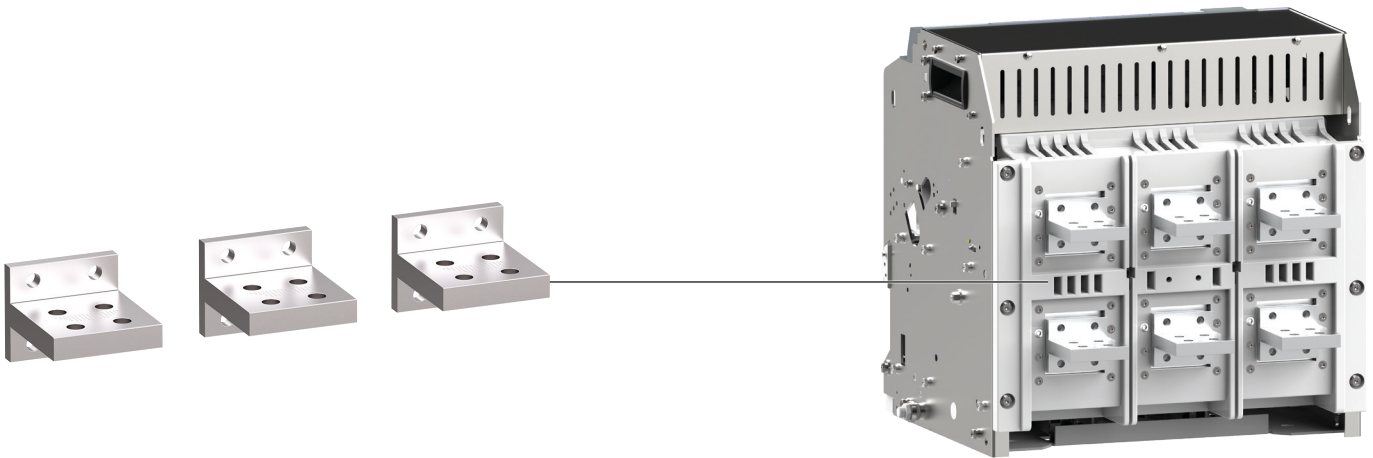

**Rear horizontal RC HW4 connections**  
For withdrawable / fixed version from 3200 A to 4000 A

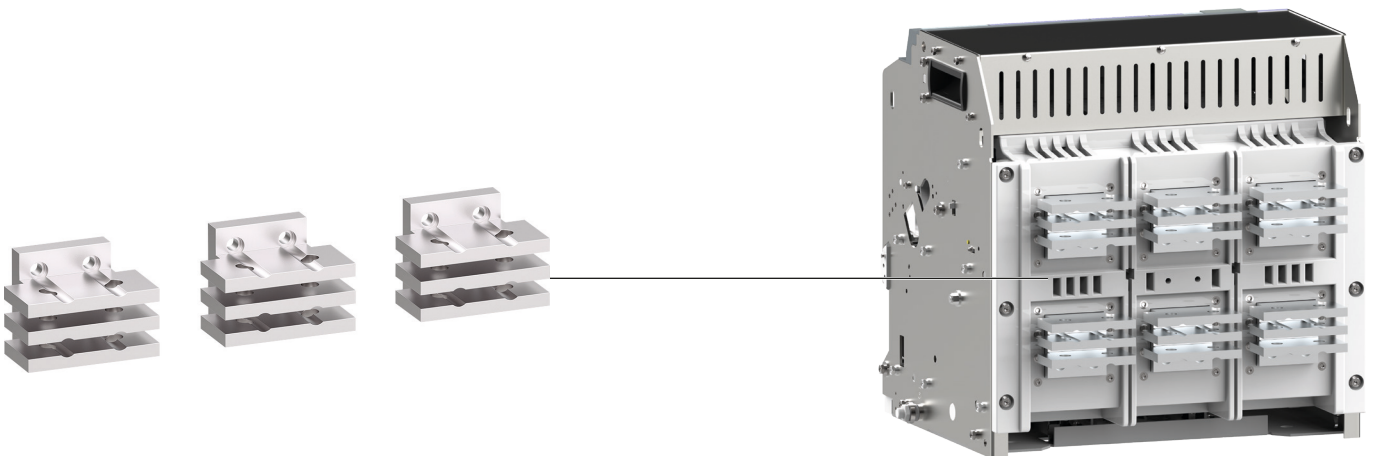

**Rear vertical / horizontal RC HW6 connections**  
For withdrawable version from 3200 A to 6300 A

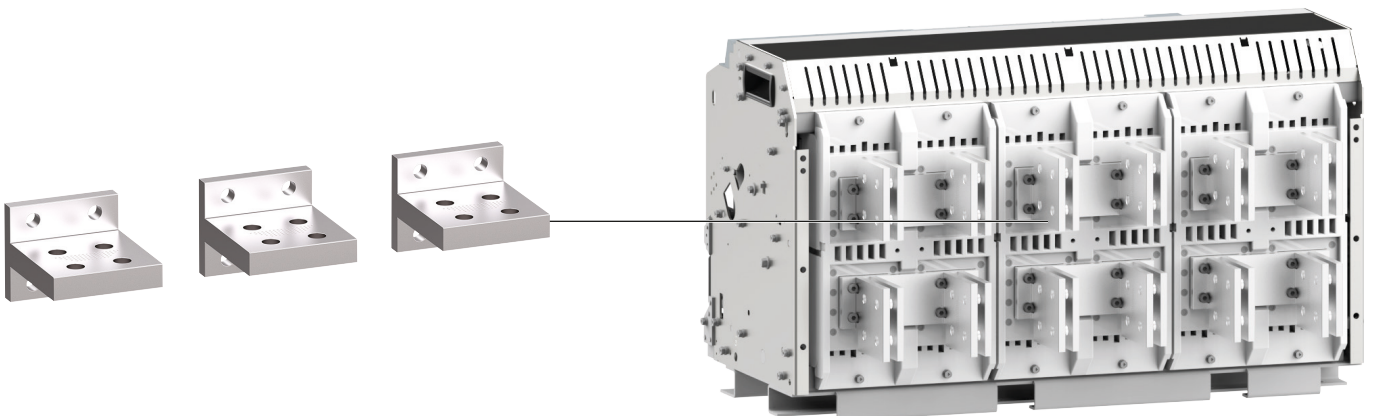

Accessories

### VCA HW1 vertical connectors

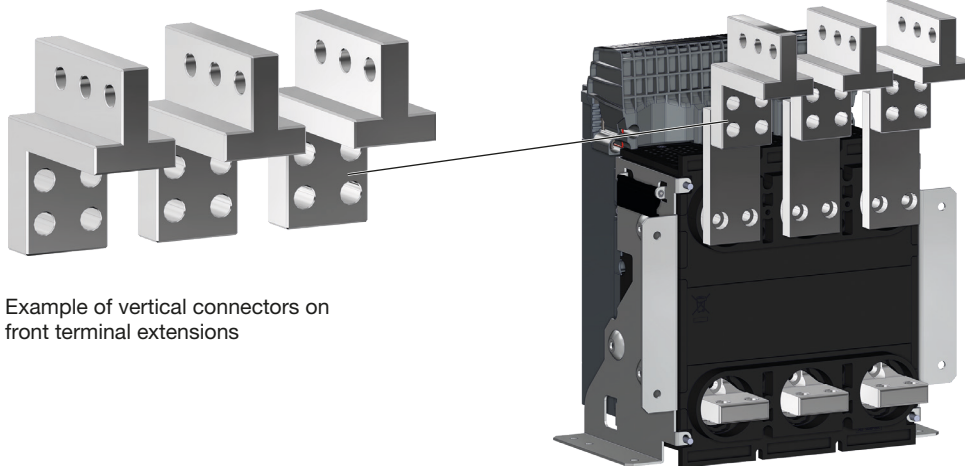

Example of vertical connectors on front terminal extensions

The vertical connectors are complementary accessories mounted on the front connections of HW1 circuit breakers. These connectors are used to facilitate connection to a vertical busbar and can be oriented towards the front or the rear of the circuit breaker according to the installation requirements.

Installing an air chamber screen is mandatory in the case of a fixed HW1 circuit breaker with the vertical connectors facing forwards.



The use of vertical connectors is prohibited if the voltage is greater than or equal to 500V.

### Spreaders SP HW1

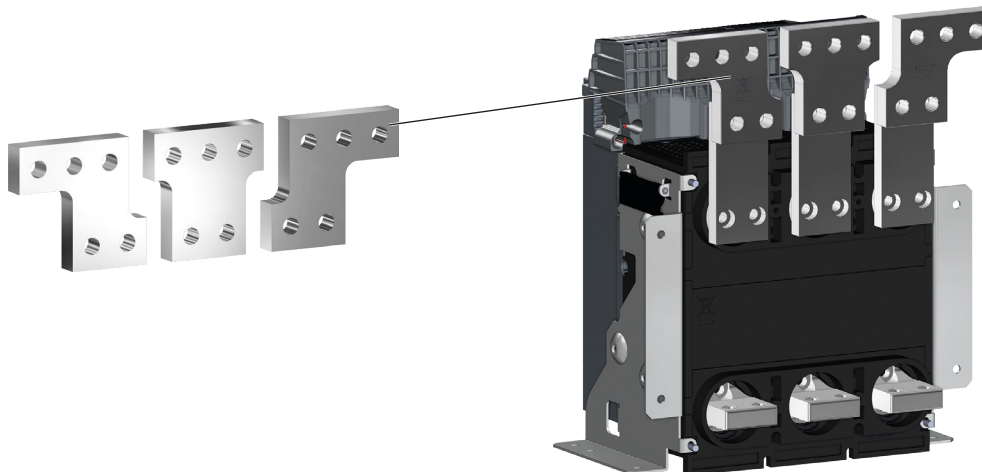

The spreaders are complementary accessories mounted on the front or rear horizontal connections of HW1 circuit breakers. They are used where the connection bars are wider than the circuit breaker sockets or for connection by means of cables. Spreaders cannot be installed with interphase barriers for the

HW1 circuit breaker.

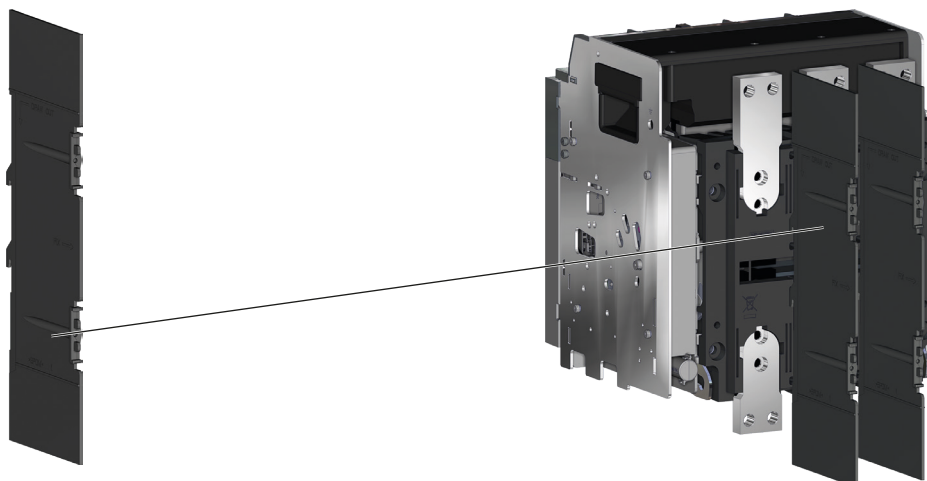

The use of spreaders is prohibited if the voltage is greater than or equal to 500 V.

**IB interphase barriers HW1, HW2 and HW4**

The interphase barriers are complementary accessories mounted vertically between the sockets of the HW1, HW2, HW4 and HW6 circuit breakers.

Each interphase barrier improves the insulation between the connection sockets and prevents arcing between two connections.



Interphase barriers cannot be installed with spreaders for the HW1 circuit breaker. Installing interphase barriers is mandatory if the voltage is greater than or equal to 500 V.

## Protection accessories overview

The mechanical protection accessories (TBC terminal cover, DF door frame, etc.) allow for enhanced safety levels when a physical intervention is being made on the installation.  
The electrical protection accessories (ENCT) help prevent deterioration in the assets and improve the level of electrical protection.

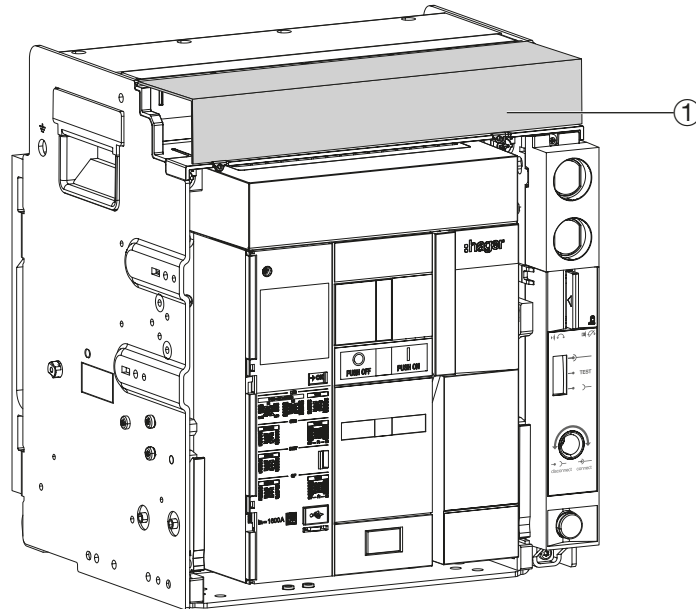

Example of an HW1 withdrawable circuit breaker

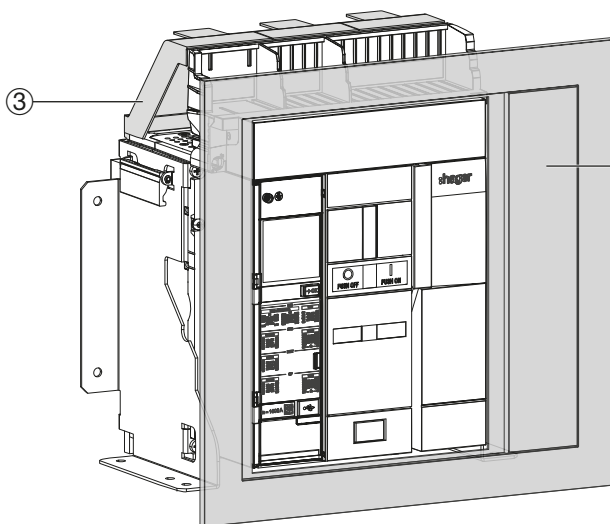

Example of an HW1 fixed circuit breaker

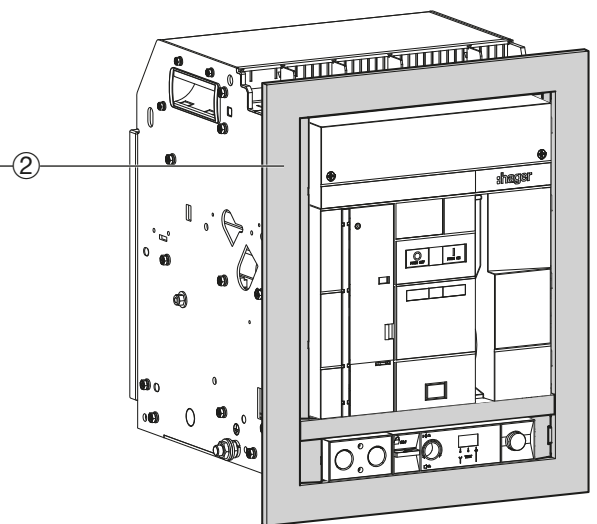

Example of an HW2 withdrawable circuit breaker

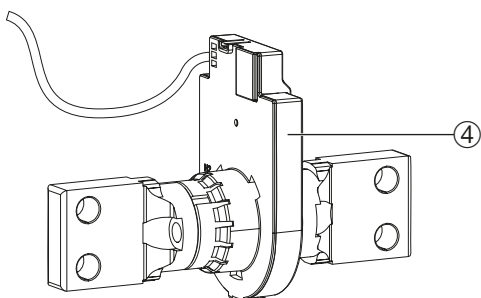

- |   |                              |          |
|---|------------------------------|----------|
| ① | TBC terminal cover           | page 119 |
| ② | DF door frame                | page 119 |
| ③ | Air chamber screen HW1       | page 120 |
| ④ | ENCT external neutral sensor | page 120 |

### TBC terminal cover



TBC HW1 terminal cover



TBC HW2, HW4 and HW6 Terminal Block Cover

The protective cover of the terminal block prevents access to the connection of electrical auxiliaries and also prevents any accidental contact. It is attached to the chassis by 2 screws.

This accessory is only available for withdrawable circuit breakers.

### DF door frame

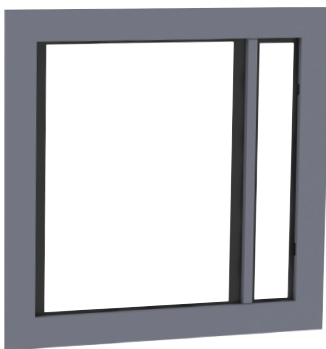

HW1 DF Door flange

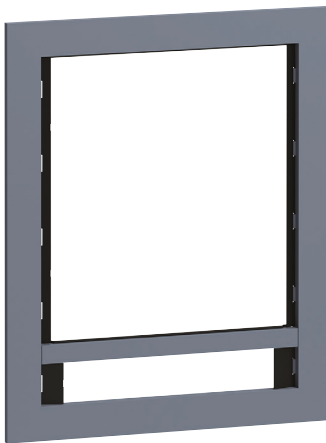

DF HW2 and HW4 Door Frame

A cut-out is made on the electrical distribution board door to accommodate the front part of a fixed or withdrawable circuit breaker.

The door frame fitted on the cut-out in the electrical distribution board door raises the protection class from IP20 to IP3X.

The door frame of the hw+ range includes flanges allowing it to be installed easily without tools. It can be installed on doors with a maximum thickness of 5 mm.

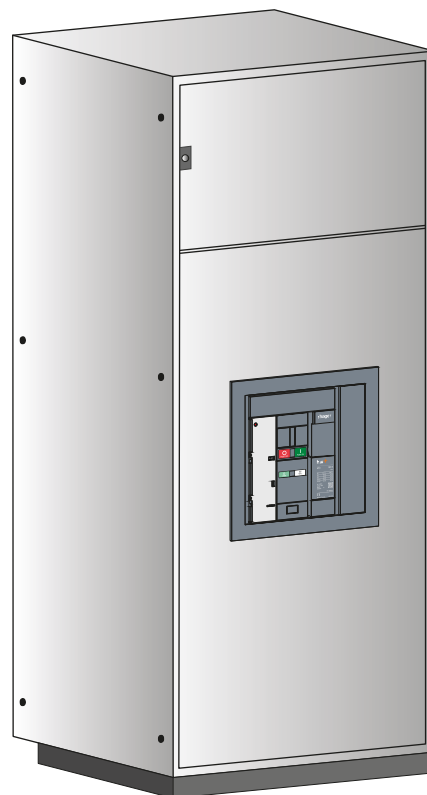

Example of a door frame for an HW1 fixed circuit breaker

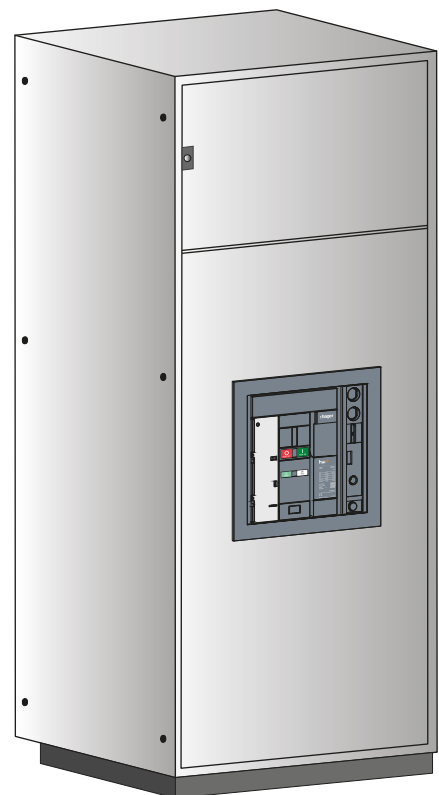

Example of a door frame for an HW1 withdrawable circuit breaker



Refer to the dimensions for the size of the cut-out in the panel. For withdrawable versions, the IP30 protection level is guaranteed in the connected position and in the test position.

### Air chamber screen HW1

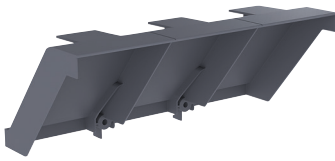

The air chamber screen is an accessory mounted on fixed circuit breakers and switch disconnectors connected with front connections. This protection screen prevents exhaust gases reaching the connections when tripping occurs. This prevents electrical arcs being created between the connections. The installation of an air chamber screen is mandatory in the case of a fixed circuit breaker fitted with front connections and vertical connectors facing forward. It should be noted that an air chamber screen is installed as standard on withdrawable circuit breakers.

### ENCT external neutral sensor

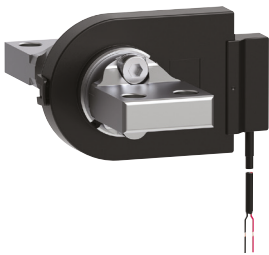

ENCT HW1 External Neutral Sensor



ENCT HW2 External Neutral Sensor

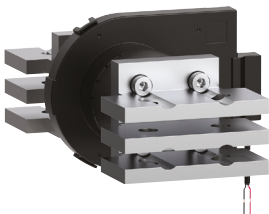

ENCT HW4 and HW6 External Neutral Sensor

The ENCT external neutral current sensor allows neutral protection to be provided on a 3-pole circuit breaker in a TN earthing system. It is installed on the neutral distribution bar generally located on the left of the circuit breaker and connects to the electronic trip unit by the circuit breaker's ESP terminal connection. 4th S1 and 4th S2: connection of the ENCT sensor for 3-pole circuit breakers.

#### Marking of the ENCT external neutral sensor terminals

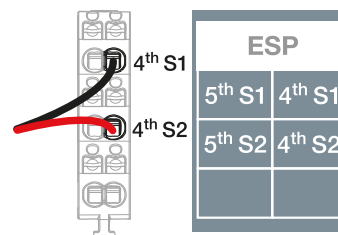

## Communication accessories overview

The communication accessories allow access to state data, electrical values and control of devices via the Modbus TCP/IP and Modbus RTU communication protocols. These accessories are compatible only with the Energy circuit breakers range.

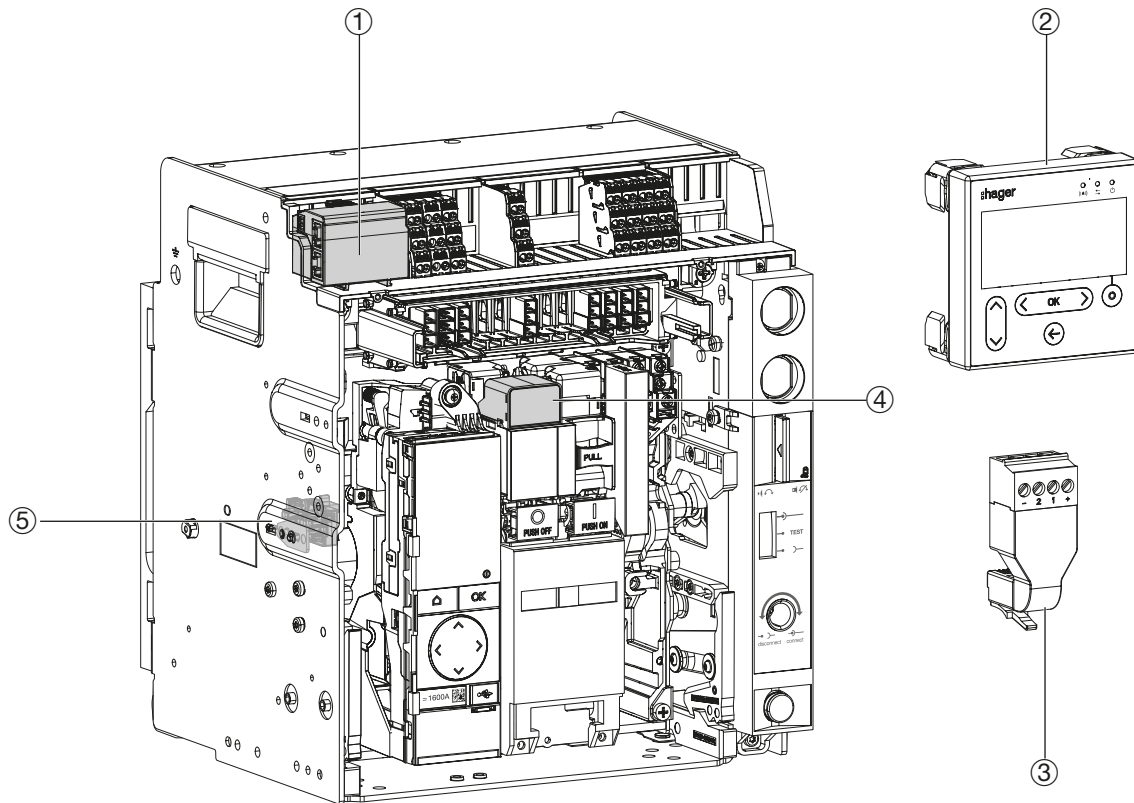

Example of a withdrawable circuit breaker

- |   |   |          |
|---|---|----------|
| ① | Communication modules                         | page 122 |
| ② | Panel display                                 | page 124 |
| ③ | Adapter for panel display                     | page 124 |
| ④ | INS insulation module for SH coil and CC coil | page 125 |
| ⑤ | Position sensor                               | page 126 |



## Communication modules

The Modbus-RTU and Modbus-TCP communication modules allow the hw+ circuit breakers with Energy trip units to be connected either to a master Modbus for an RTU module, or to a client Modbus for a TCP module



Modbus RTU module

The Modbus-RTU communication module connects to an RS 485 serial communication network using the Modbus-RTU protocol.



Modbus TCP module

The Modbus-TCP communication module connects to an Ethernet network using the Modbus TCP/IP protocol.

These communication modules are compatible and specially indicated to interface with the data server agardio.manager HTG411H.

They enable the following principal functions:

- Reading of diagnostic and measurement data,
- Reading of state conditions and remote operations,
- Changing and displaying protection settings,
- Reading of identification and configuration data of the circuit breakers,
- Remote control of the circuit breaker,
- Setting the clock and synchronisation,
- The configuration of protections and alarms,
- The configuration and remote control of multi-tariff counters,
- the setting of various other parameters,
- remote inhibition of advanced protections,
- remote switching between profile A and profile B,
- the use of other embedded commands,
- the transfer of the timestamped events history.

### Modbus-RTU module technical specifications

The Modbus-RTU HWY965H communication module has two RJ45 sockets to facilitate connection into the Modbus daisy chain. It does not have a 120 Ω terminal resistor. It is recommended that the reference item HTG467H be used to connect a 120 Ω terminal resistor to the module.

MODBUS RTU	Value	Description
ADDRESS	1 to 247	Modbus address setting
BAUD	4800; 9600; 19200; 38400	BAUD rate setting
PARITY	Odd	1 stop bit
	Even	1 stop bit
	No	2 stop bits
STOP BIT	1 or 2	Setting the parity includes automatically managing the automatic adjustment of the number of Stop bits.



**Modbus-TCP module technical specifications**

The Modbus-TCP HWY966H communication module has an RJ45 socket to connect to an Ethernet bus. It does not have a router function.

This module includes a secure web server (HTTPS) enabling configuration of the IP parameters (static or dynamic configuration), time synchronisation mode and TLS security for the web servers and Modbus TCP/IP servers.

MODBUS TCP	Default value	Description
DHCP	Off	Off: the IP address must be configured manually On: the IP address is assigned automatically by the internet network
IP ADDRESS	172.16.1.1	Enter the unused fixed IP address corresponding to the network parameter
SUBNET MASK	255.255.255.0	Enter the subnet mask
GATEWAY	0.0.0.0	Enter the address of the network gateway

**Electrical characteristics**

Rated DC supply voltage	24 V (+/- 30 %) SELV
Modbus-RTU module power consumption (HWY965H)	14 mA
Modbus-TCP module power consumption (HWY966H)	38 mA

## Panel display



The HTD210H panel display allows the state, measurement and setting information for a door or panel of the electrical assembly to be displayed. It also allows the main protection and alarm settings to be changed.



HWY210H adapter

The HWY210H adapter is necessary to connect the HTD210H panel display, a 24V DC power supply and the cables enabling the connection to the terminals CIP 1 and CIP 2.

### Functions of the HTD210H panel display

It allows the following to be displayed:

- the protection parameters
- the measured values
- the alarm management parameters
- the optional alarm and trip histories
- the circuit breaker's status and identification information.

It allows the following to be changed:

- the circuit breaker protection parameters
- the measurement parameters
- the date and time
- the optional alarms and overload prealarms.

It also allows the minimum/maximum measurement counters to be reset and the optional alarm and trip logs to be erased.

### Electrical characteristics

Rated DC supply voltage	24 V (+/- 30 %) SELV
HTD210H panel display power consumption	85 mA

### Environmental and mechanical characteristics

Operating temperature range	-10 °C...+55 °C
Storage temperature	-20 °C...+70 °C
Pollution degree	2
Installation category	III
IP class of front side	IP65
IP class of back side	IP20
Mechanical protection (front face)	IK07

### Physical characteristics

Dimensions L x H x D	97 x 97 x 46 mm
Panel/door cut-out dimensions	92 x 92 mm
Weight	165 g
Display dimensions	37 x 78 mm
Type of connector	RJ9
Cable length max.	10 m

**INS insulation module for SH coil and CC coil**



The INS insulation module provides enhanced insulation between the coils and the trip unit. It is also necessary to enable communication with a shunt trip coil or closing coil. This allows the coils to be controlled remotely by using a Modbus-RTU or TCP communication module.

This communication function is only possible with an Energy trip unit.

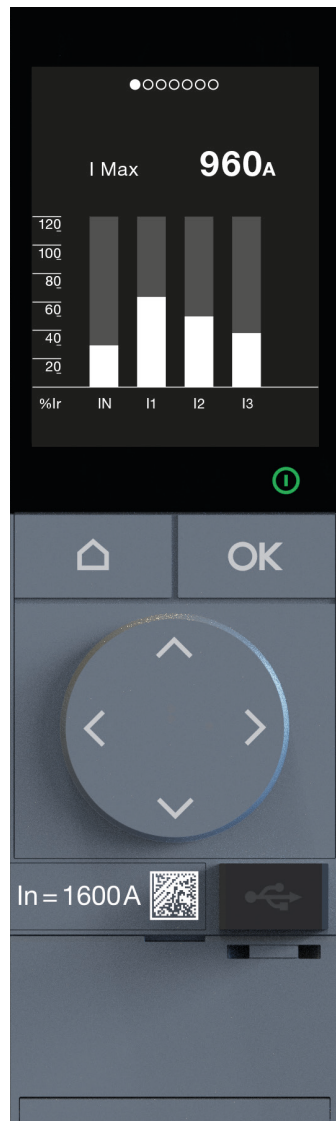

sentinel Energy trip unit

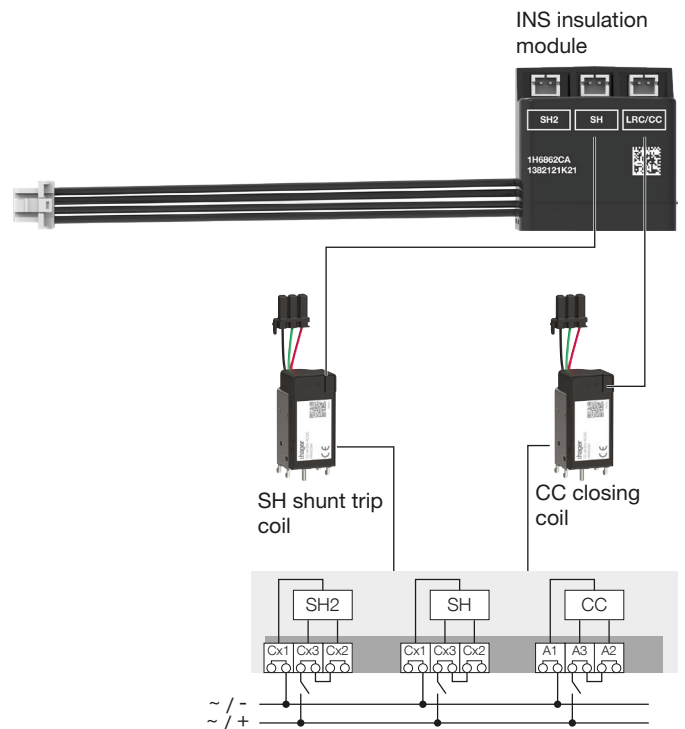

Accessories

## Position sensor

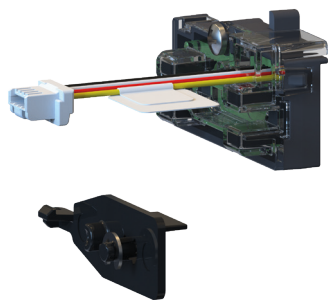

The position sensor is an accessory that allows the position of a withdrawable circuit breaker to be signalled via the Modbus communication.

The possible positions are:

- Connected
- Test
- Unknown (1).

The sensor is directly connected to the sentinel Energy electronic trip unit via cable.

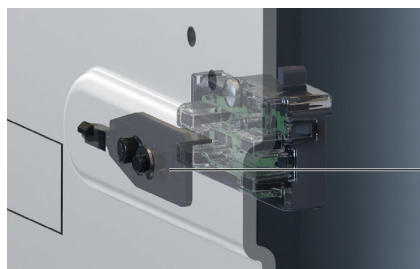

The position blade is installed inside the chassis, on the left side.

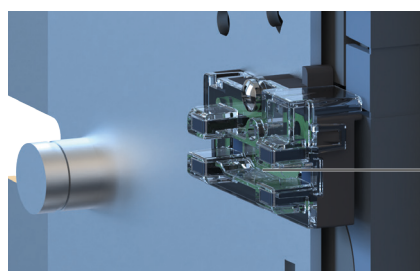
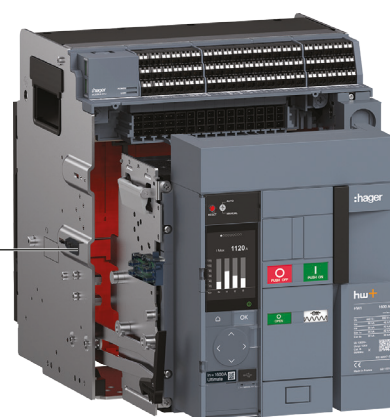

The sensor is installed on the left of the withdrawable circuit breaker.

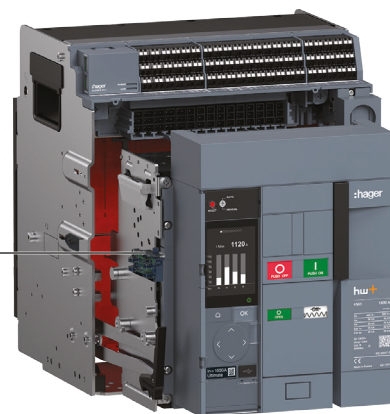

(1) This can be a Disconnected position or an intermediate position: when the circuit breaker is between the Connected and Test position.

# Installation and operating recommendations

Page

---

01 Installation and operating conditions	128
02 Safety clearances and minimum distances	131
03 Power loss	133

---

### Altitude derating

Up to an altitude of 2000 m above sea level, there is no derating required for the electrical properties of hw+ circuit breakers.

However, above 2000 m, due to decrease in air density, the heat loss ability of the circuit breaker is reduced and decreases the dielectric strength. A derating factor must be applied to the electrical characteristics; for that, please consult your local Hager contact.

### Circuit breaker marking

Markings on hw+ circuit breaker comply with the International Standard IEC 60947-1, Appendix C.

### Vibrations

hw+ circuit breakers withstand mechanical vibrations.

They comply with the standard IEC 60068-2-52:

- 2.0 to 13.2 Hz and amplitude  $\pm 1$  mm
- 13.2 to 100 Hz acceleration  $\pm 0.7$  G
- Resonance frequency  $\pm 1$  mm/ $\pm 0.7$  G for 90 minutes

Excessive vibration may cause nuisance (false) tripping and/or damage to connections and/or mechanical parts.

### Electromagnetic interference

hw+ circuit breakers are protected against:

- overvoltage caused by circuit switching,
- overvoltage caused by atmospheric disturbances or a distribution system outage (e.g. failure of a lighting system),
- devices emitting radio waves (radios, walkie-talkies, radar, etc.),
- electrostatic discharges produced directly by users.

hw+ circuit breakers have successfully passed the electromagnetic compatibility tests (EMC) with immunity levels listed in the chapter on General Characteristics.

### IP protection ratings

The IP protection class of the hw+ circuit breakers is dependent on their integration into their cabinets. The front and the connection terminal blocks are IP20.

IP3x is also achieved if the hw+ circuit breaker is installed in a switchboard with use of the „DF door frame“ - Page 119.

**Mounting position**

The circuit breakers must be mounted vertically.

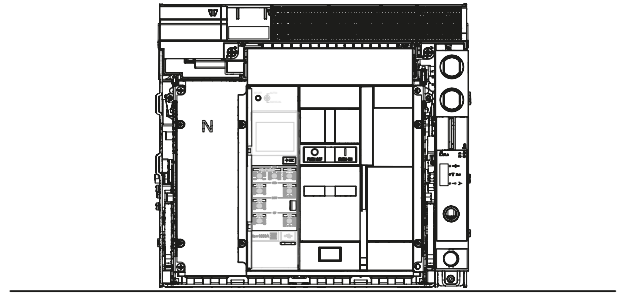
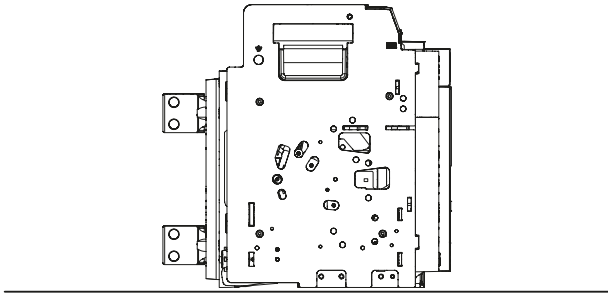

**Direction of power supply**

The circuit breakers can be powered from either the top or the bottom connections, without any decrease in performance. All connections and isolation accessories can be used on circuit breakers powered either from the top or from the bottom.

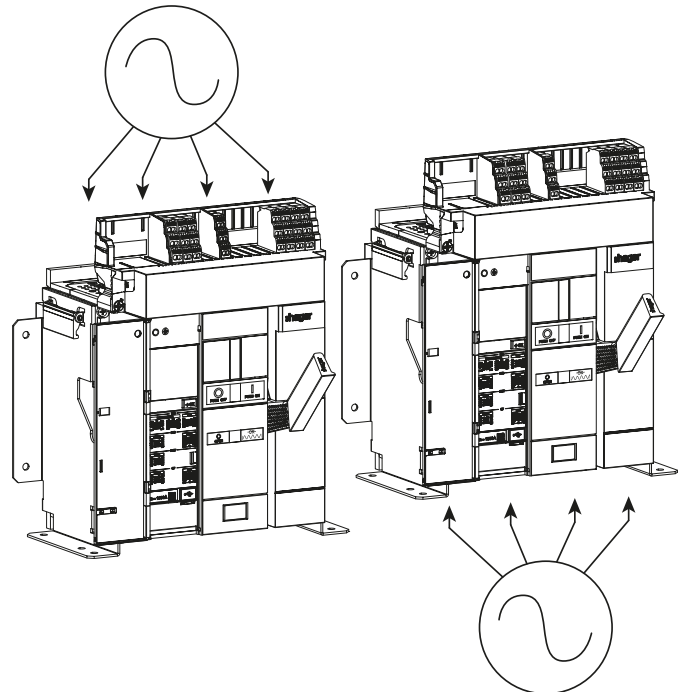

### Reclassification due to temperature

hw+ circuit breakers are calibrated at an ambient temperature of 50°C for overload protection. The temperature reclassifications given below are as per the IEC 60947-2 conditions for tests performed in the open air.

### Influence of ambient temperature on rated current values (In)

The temperature of electronic circuit breakers depends on the operating current and ambient temperature.

However, ambient temperature does not affect the protection setting of electronic circuit breakers.

Derating table for rated current:

#### Fixed version HW1

In (A)	Temperature °C				In (A)	Temperature °C			
	50	60	65	70		50	60	65	70
400	400	400	400	400	400	400	400	400	400
630	630	630	630	630	630	630	630	630	630
800	800	800	800	800	800	800	800	800	800
1000	1000	1000	1000	1000	1000	1000	1000	1000	1000
1250	1250	1250	1250	1250	1250	1250	1250	1250	1250
1600	1600	1600	1600	1530	1600	1600	1600	1530	1457

#### Drawout version HW1

#### Fixed version HW2

In (A)	Temperature °C				In (A)	Temperature °C			
	50	60	65	70		50	60	65	70
630	630	630	630	630	630	630	630	630	630
800	800	800	800	800	800	800	800	800	800
1000	1000	1000	1000	1000	1000	1000	1000	1000	1000
1250	1250	1250	1250	1250	1250	1250	1250	1250	1250
1600	1600	1600	1600	1600	1600	1600	1600	1600	1600
2000	2000	2000	2000	2000	2000	2000	2000	2000	1960
2500	2500	2500	2475	2460	2500	2500	2485	2365	2240

#### Drawout version HW2

#### Fixed version HW4

In (A)	Temperature °C				In (A)	Temperature °C			
	50	60	65	70		50	60	65	70
1000	1000	1000	1000	1000	1000	1000	1000	1000	1000
1250	1250	1250	1250	1250	1250	1250	1250	1250	1250
1600	1600	1600	1600	1600	1600	1600	1600	1600	1600
2000	2000	2000	2000	2000	2000	2000	2000	2000	2000
2500	2500	2500	2500	2500	2500	2500	2500	2500	2500
3200	3200	3200	3200	3200	3200	3200	3200	3160	3000
4000	4000	4000	4000	3800	4000	4000	3970	3790	3580

#### Drawout version HW4

#### Fixed version HW6

In (A)	Temperature °C				In (A)	Temperature °C			
	50	60	65	70		50	60	65	70
3200	3200	3200	3200	3200	3200	3200	3200	3200	3200
4000	4000	4000	4000	4000	4000	4000	4000	4000	4000
5000	5000	5000	4960	4690	5000	5000	5000	4950	4680
6300	6300	6300	6120	5800	6300	6300	6150	5860	5540

#### Drawout version HW6



**Safety clearances and minimum distances**

The safety clearance distances between the circuit breaker and its enclosure parts (grounded metal parts) must be maintained to prevent arcing faults.

In some cases where other specifications require different isolation distances to those shown here, the greater distance must be maintained. If two different circuit breaker models are installed one above the other, the safety clearance distance between the two models should comply with the model specifications of the bottom circuit breaker.

**Minimum distance between the hw+ circuit breaker and the top, bottom or side metal parts of the cabinet**

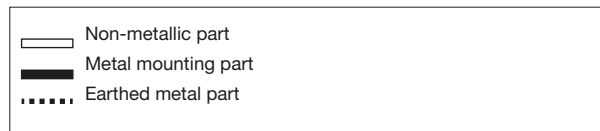
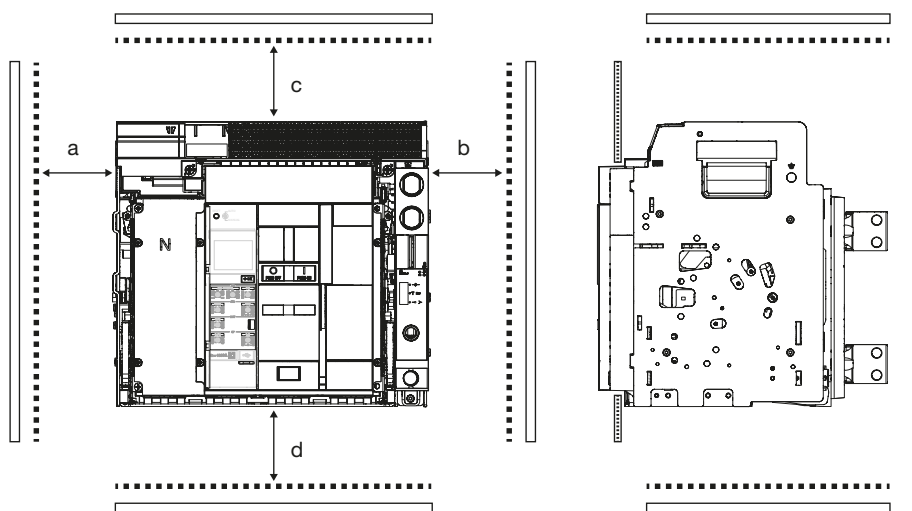

**Fixed version**

≤ 690 V CA	Earthed metal part	Non-metallic part
<b>a (mm)</b>	≥ 60	0
<b>b (mm)</b>	≥ 60	0
<b>c (mm)</b>	≥ 100	0
<b>d (mm)</b>	0	0

**Drawout version**

≤ 690 V CA	Earthed metal part	Non-metallic part
<b>a (mm)</b>	0	0
<b>b (mm)</b>	0	0
<b>c (mm)</b>	0	0
<b>d (mm)</b>	0	0



**WARNING**

**Risk of electric shock**

**Danger to life, risk of injury due to electric shock, or risk of serious injury.**

Make sure that the device is only operated by qualified personnel in accordance with to the installation standards in force in the relevant country.

To ensure the safety of people and the installation, comply with the following safety clearances:

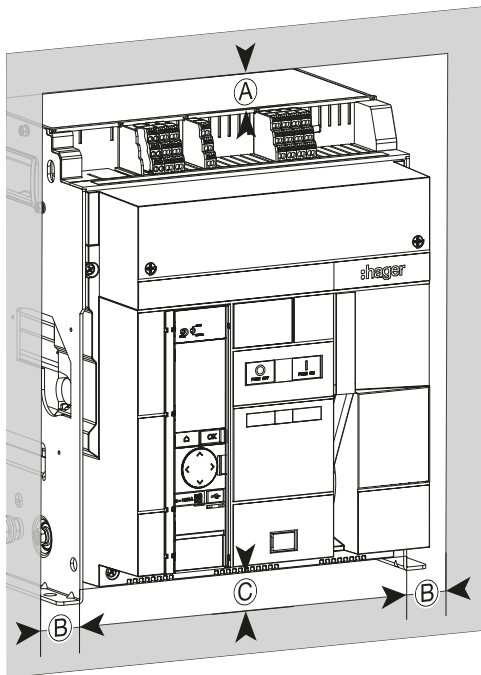

HW2, HW4 and HW6 fixed circuit breaker

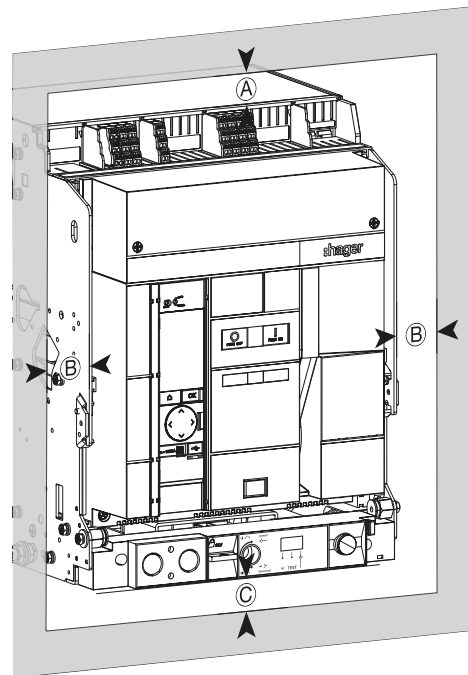

HW2, HW4 and HW6 drawout circuit breaker

Circuit breaker	Distance	Insulating material	Metallic material	Circuit breaker live (mm)
Fixed	Ⓐ	0	0	0
	Ⓑ	0	0	60
	Ⓒ	0	0	0
Drawout	Ⓐ	0	0	0
	Ⓑ	0	0	60
	Ⓒ	0	0	0

### Power loss

The power dissipation values of hw+ circuit breakers are used to calculate the temperature rise in the switchboard in which they are installed.

The values given in the tables below are typical values for a device operating at a full rated load with a frequency of 50/60 Hz.

The value given is the power loss per pole at  $I_n$ , 50/60 Hz. Measurement and calculation of power loss are carried out in compliance with the recommendations of Appendix G of standard IEC 60947-2.

Total power loss at full rated load and a frequency of 50/60 Hz is equal to the power losses per pole multiplied by 3.

### Power dissipation of HW1 circuit breakers

Number of poles	Version	Rating $I_n$ (A)	P / pole (W)	Total P / circuit breaker (W)
3 / 4	Fixed	400	1.7	5.2
		630	4.6	13.7
		800	7.9	23.8
		1000	15.7	47
		1250	21.7	65.1
		1600	43.4	130.2
	Drawout	400	6.2	18.6
		630	15.7	47.1
		800	25.9	77.6
		1000	43.7	131.1
		1250	65.5	196.5
		1600	119.5	358.6

### Power dissipation of HW2 circuit breakers

Number of poles	Version	Rating $I_n$ (A)	P / pole (W)	Total P / circuit breaker (W)
3 / 4	Fixed	630	2.7	8
		800	4.5	13.4
		1000	6.9	20.8
		1250	11.5	34.4
		1600	19.4	58.2
		2000	31.4	94.2
		2500	50.5	151.4
	Drawout	630	6.3	19
		800	10.5	31.4
		1000	16.6	49.8
		1250	26.8	80.4
		1600	46.1	138.2
		2000	74.1	222.2
		2500	119.8	359.4

**Power dissipation of HW4 circuit breakers**

Number of poles	Version	Rating In (A)	P / pole (W)	Total P / circuit breaker (W)
3 / 4	Fixed	1000	6.3	18.8
		1250	10.8	32.4
		1600	18.7	56.2
		2000	29.7	89.2
		2500	48.8	146.4
		3200	79.9	239.8
		4000	130.0	390.1
	Drawout	1000	10.6	31.8
		1250	16.8	50.4
		1600	28.7	86.2
		2000	46.1	138.2
		2500	75.5	226.4
		3200	165.6	496.8
		4000	266.7	800.1

**Power dissipation of HW6 circuit breakers**

Number of poles	Version	Rating In (A)	P / pole (W)	Total P / circuit breaker (W)
3 / 4	Fixed	3200	44.6	133.9
		4000	77.5	232.4
		5000	132.7	398.0
		6300	220.2	661.0
	Drawout	3200	88.0	263.9
		4000	145.8	437.4
		5000	242.7	728.0
		6300	391.9	1176.0

**Additional power loss**

Power loss caused by the connection accessories has to be taken into account. Thus, the total power loss is equal to the sum of the power losses of the circuit breaker and all the corresponding connection accessories.

**Power dissipation of circuit breakers + accessories for HW1**

Number of poles	Version	Rating In (A)	Total P / circuit breaker (W)	Additional P/ accessory kit (W)				
				Rear connections	Front connections	Front connections with short terminal extensions in bottom position	Terminal extension spreaders	Vertical adapters
3	Fixed	400	5.2	2.5	3.3	/	3.3	3.6
		630	13.7	6.3	8.2	/	8.1	9
		800	23.8	10.2	13.2	/	13.1	14.5
		1000	47	15.9	20.7	/	20.4	22.7
		1250	65.1	24.8	32.3	/	31.9	35.5
		1600	130.2	40.7	53	/	52.2	58.2
	Drawout	400	18.6	2.5	3.5	5.2	3.3	3.6
		630	47.1	6.3	8.7	13	8.1	9
		800	77.6	10.2	14.1	20.9	13.1	14.5
		1000	131.1	15.9	22	32.6	20.4	22.7
		1250	196.5	24.8	34.3	50.9	31.9	35.5
		1600	358.6	40.7	56.2	83.4	52.2	58.2
4	Fixed	400	5.2	2.5	3.3	/	3.7	3.6
		630	13.7	6.3	8.2	/	9.1	9
		800	23.8	10.2	13.2	/	14.6	14.5
		1000	47	15.9	20.7	/	22.8	22.7
		1250	65.1	24.8	32.3	/	35.6	35.5
		1600	130.2	40.7	53	/	58.3	58.2
	Drawout	400	18.6	2.5	3.5	5.2	3.7	3.6
		630	47.1	6.3	8.7	13	9.1	9
		800	77.6	10.2	14.1	20.9	14.6	14.5
		1000	131.1	15.9	22	32.6	22.8	22.7
		1250	196.5	24.8	34.3	50.9	35.6	35.5
		1600	358.6	40.7	56.2	83.4	58.3	58.2

Installation and operating recommendations

### Power dissipation of circuit breakers + accessories for HW2

Number of poles	Version	Rating In (A)	Total P / circuit breaker (W)	Additional P/ accessory kit (W)
				Rear connections
3	Fixed	630	8.0	2.0
		800	13.4	13.4
		1000	20.8	20.8
		1250	34.4	34.4
		1600	58.2	12.9
		2000	94.2	20.4
		2500	151.4	31.8
	Drawout	630	19.0	19.0
		800	31.4	31.4
		1000	49.8	5.1
		1250	80.4	7.8
		1600	138.2	12.9
		2000	222.2	20.4
		2500	359.4	31.8
4	Fixed	630	8.0	2.0
		800	13.4	3.3
		1000	20.8	5.1
		1250	34.4	7.8
		1600	58.2	12.9
		2000	94.2	20.4
		2500	151.4	31.8
	Drawout	630	19.0	2.0
		800	31.4	3.3
		1000	49.8	5.1
		1250	80.4	7.8
		1600	138.2	12.9
		2000	222.2	20.4
		2500	359.4	31.8

**Power dissipation of circuit breakers + accessories for HW4**

Number of poles	Version	Rating In (A)	Total P / circuit breaker (W)	Additional P/ accessory kit (W)
				Rear connections
3	Fixed	1000	18.8	5.1
		1250	32.4	7.8
		1600	56.2	12.9
		2000	89.2	20.4
		2500	146.4	31.8
		3200	239.8	36.6
		4000	390.1	57.5
	Drawout	1000	31.8	5.1
		1250	50.4	7.8
		1600	86.2	12.9
		2000	138.2	20.4
		2500	226.4	31.8
		3200	496.8	36.6
		4000	800.1	57.5
4	Fixed	1000	18.8	5.1
		1250	32.4	7.8
		1600	56.2	12.9
		2000	89.2	20.4
		2500	146.4	31.8
		3200	239.8	36.6
		4000	390.1	57.5
	Drawout	1000	31.8	5.1
		1250	50.4	7.8
		1600	86.2	12.9
		2000	138.2	20.4
		2500	226.4	31.8
		3200	496.8	36.6
		4000	800.1	57.5

Power dissipation of circuit breakers + accessories for HW6

Number of poles	Version	Rating In (A)	Total P / circuit breaker (W)	Additional P/ accessory kit (W)
				Rear connections
3	Fixed	3200	133.9	23.0
		4000	232.4	28.8
		5000	398.0	36.0
		6300	661.0	57.3
	Drawout	3200	263.9	23.0
		4000	437.4	28.8
		5000	728.0	36.0
		6300	1176.0	57.3
4	Fixed	3200	133.9	23.0
		4000	232.4	28.8
		5000	398.0	36.0
		6300	661.0	57.3
	Drawout	3200	263.9	23.0
		4000	437.4	28.8
		5000	728.0	36.0
		6300	1176.0	57.3



# Dimensions

Page

---

01 Circuit breakers

140

---

02 Connections

149

---

3-poles - Fixed version HW1

Front view

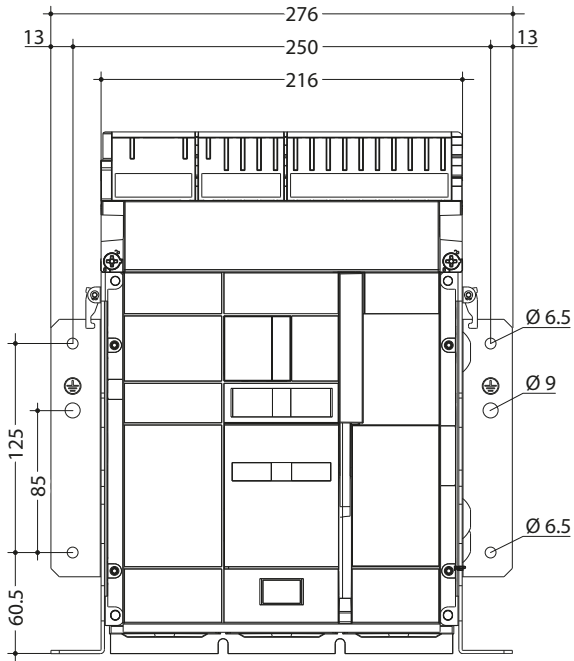

Side view

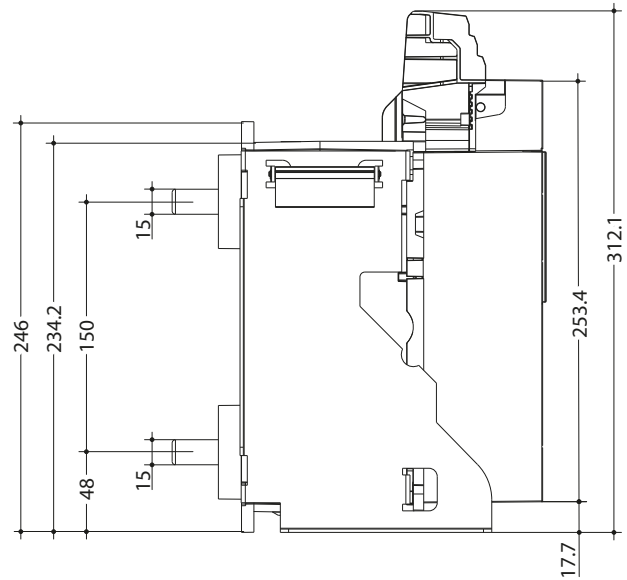

Top view

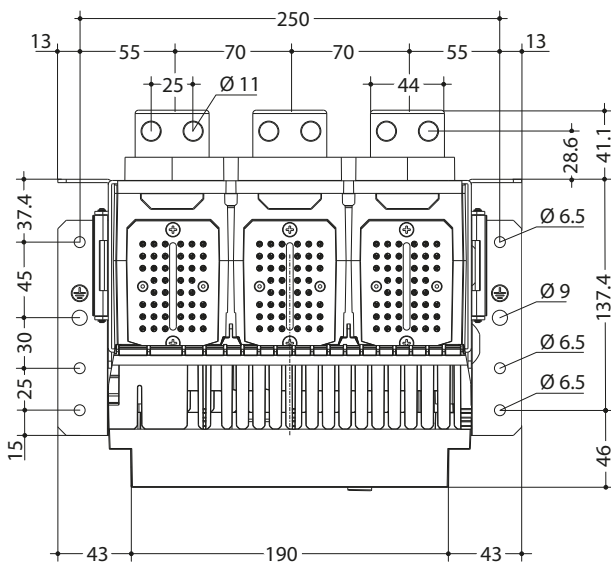

4-poles - Fixed version HW1

Front view

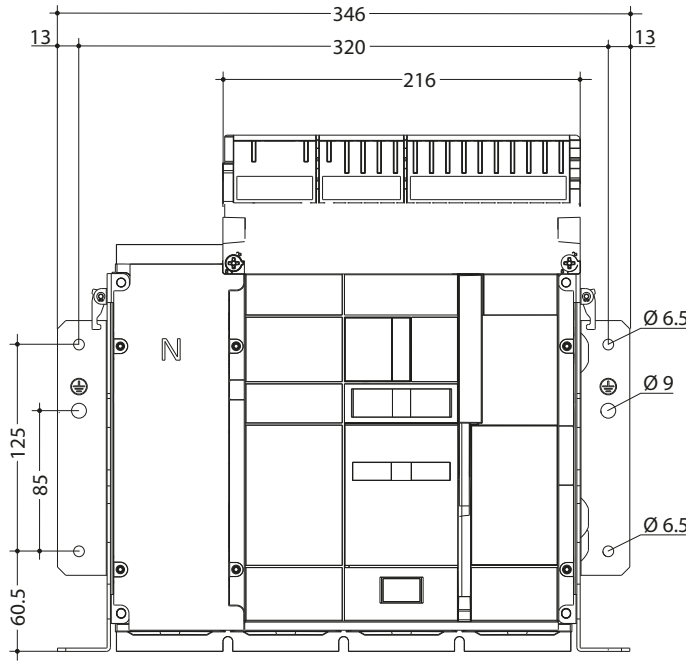

Side view

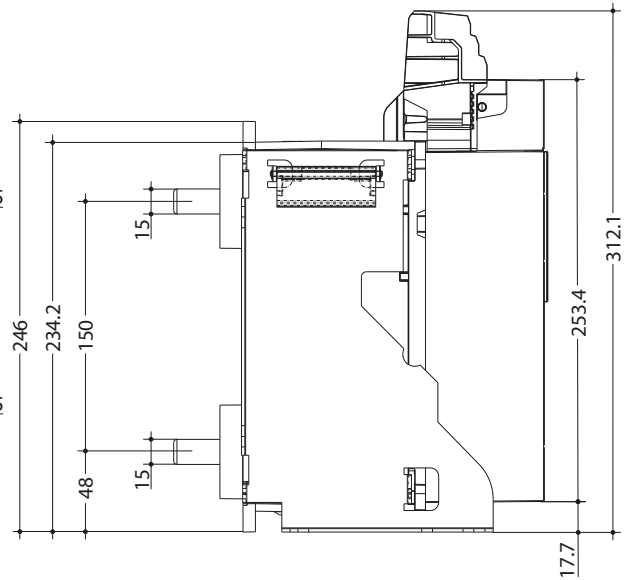

Top view

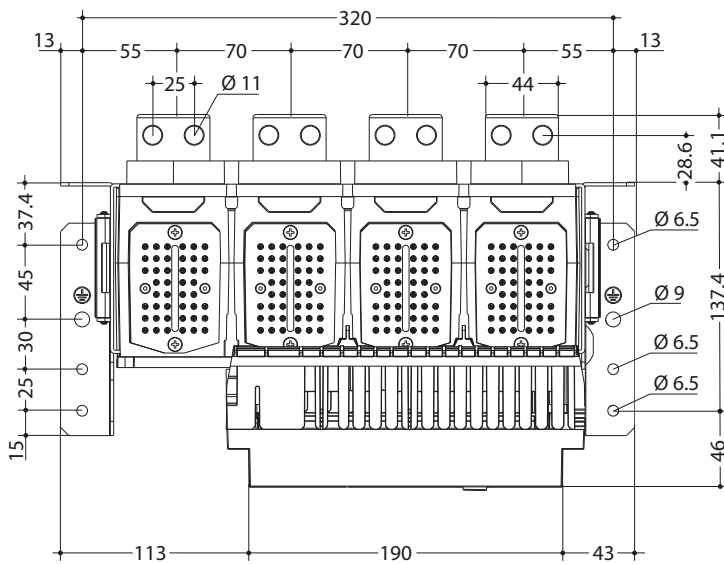

3-poles - Drawout version HW1

Front view

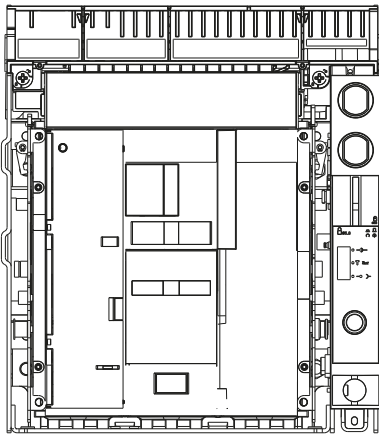

Side view

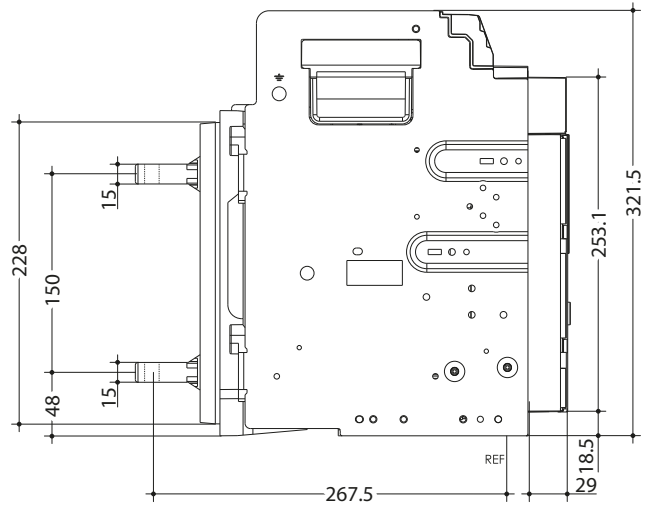

Top view

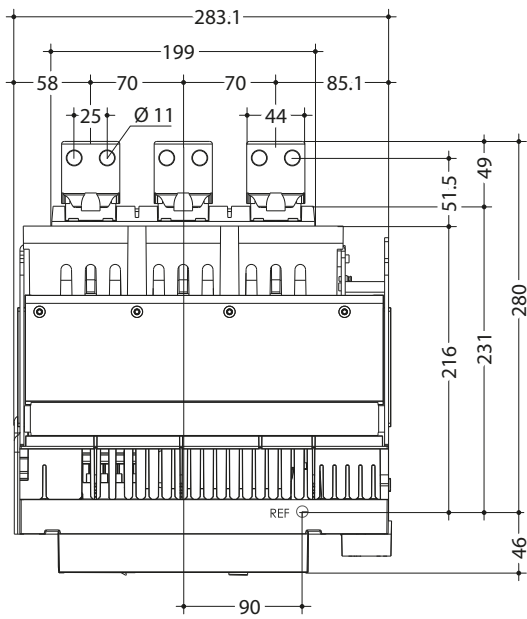

Test position

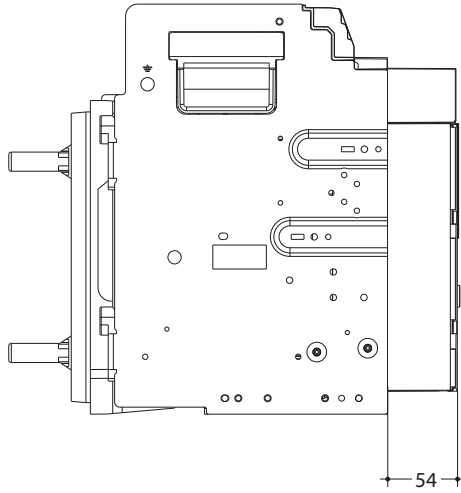

Disconnected position

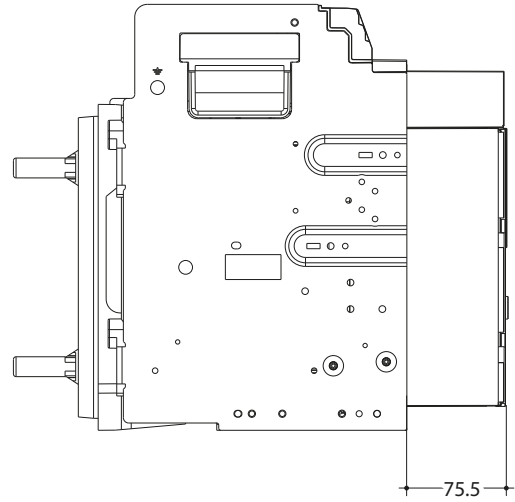

**Chassis mounting**

Bottom view

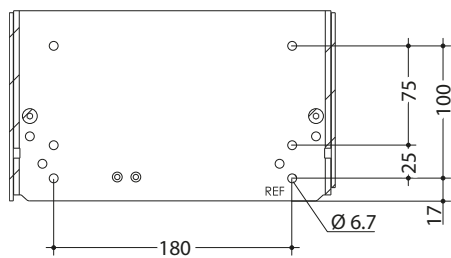

Rear view

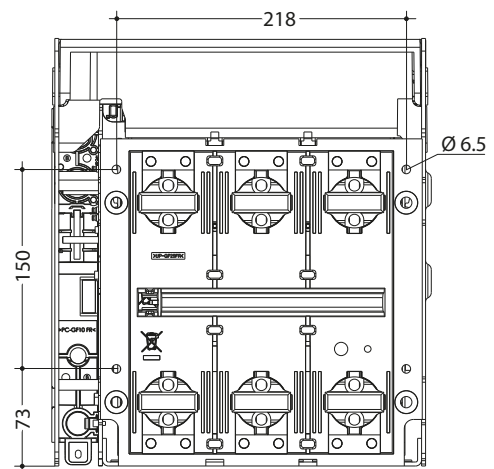

4-poles - Drawout version HW1

Front view

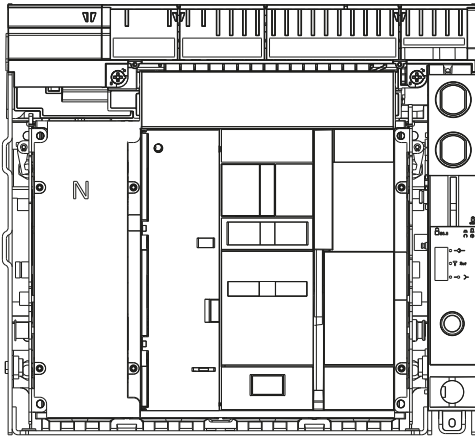

Side view

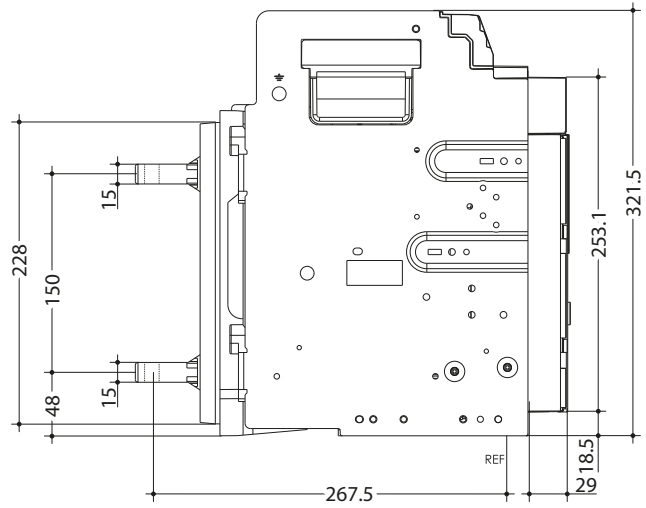

Top view

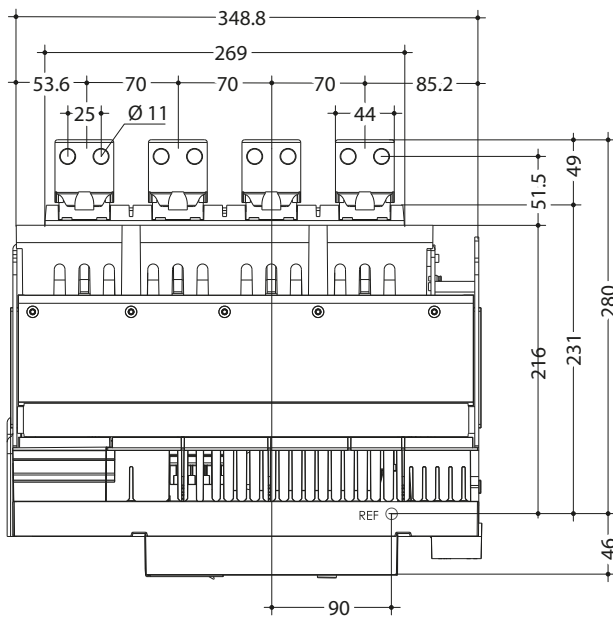

Test position

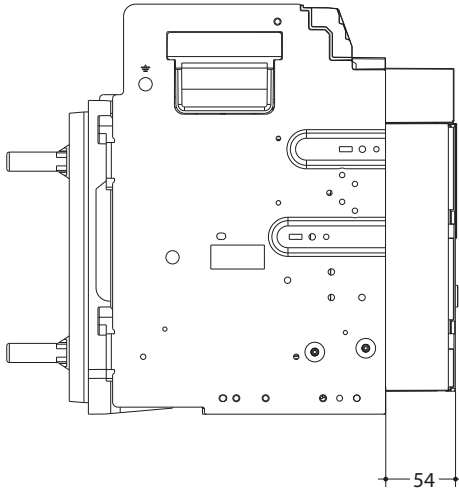

Disconnected position

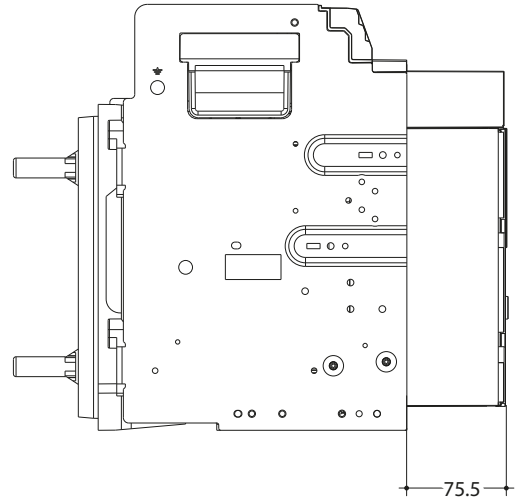

Chassis mounting  
Bottom view

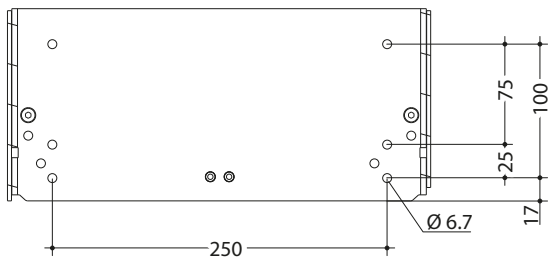

Rear view

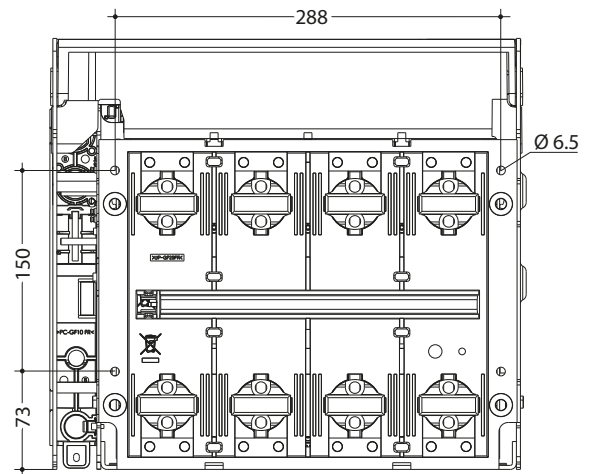

**Fixed version HW2 HW4 or HW6**

To install a fixed HW2, HW4 or HW6 circuit breaker, comply with the following dimensions for mounting:

Dimensions (max. value in mm)	HW2		HW4		HW6	
	3 poles	4 poles	3 poles	4 poles	3 poles	4 poles
Width A	385	480	478	604	856	1 108
Height B	416	416	416	416	416	416
Depth C with connections	373	373	373	373	422	422
Pitch distance D fastening depth	160	160	160	160	160	160
Pitch distance E fastening width	348	443	441	567	819	1 071

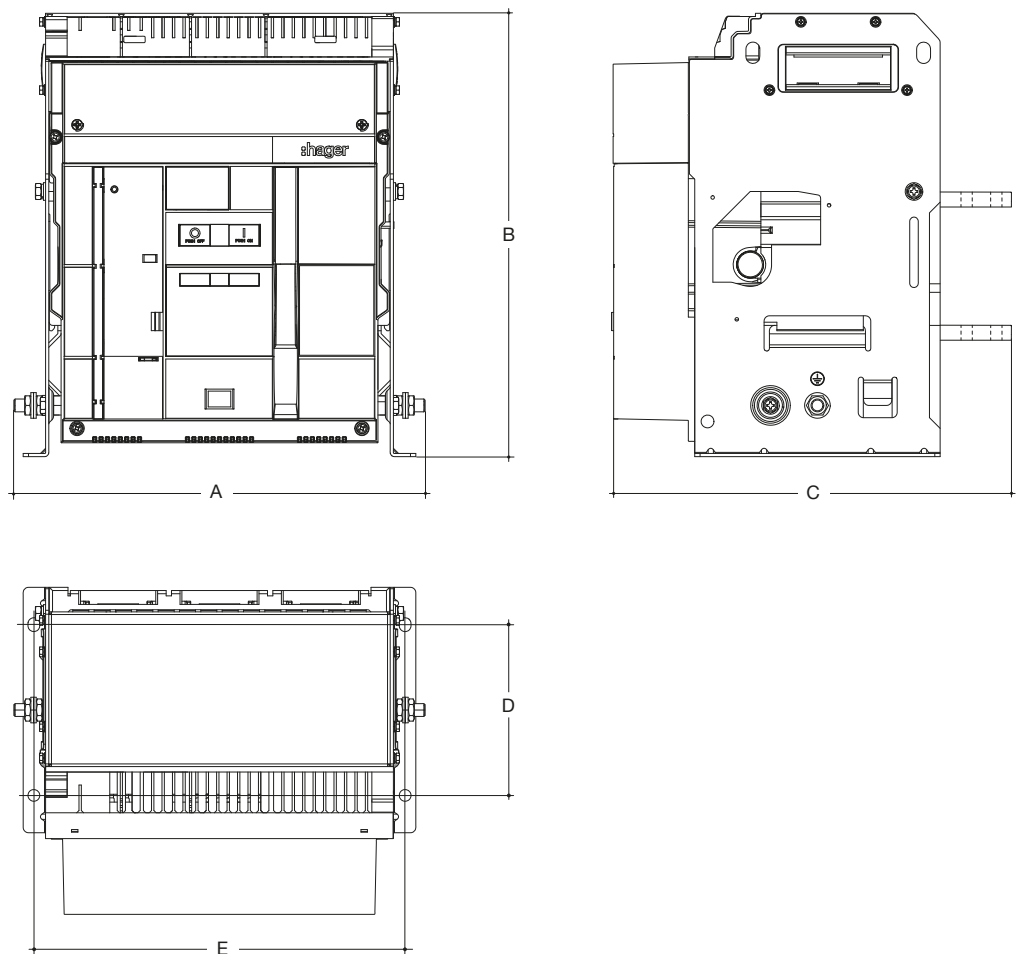



**Drawout version HW2 HW4**

To install a drawout HW2 or HW4 circuit breaker, comply with the following dimensions for mounting:

Dimensions (max. value in mm)	HW2		HW4	
	3 poles	4 poles	3 poles	4 poles
Width A	400	495	493	619
Height B	450	450	450	450
Depth C with connections	465	465	465	465
Pitch distance D fastening depth	175	175	175	175
Pitch distance E fastening width	265	360	325	440
Protrusion F circuit breaker	in the Test position	40	40	40
	in the Disconnected position	56	56	56

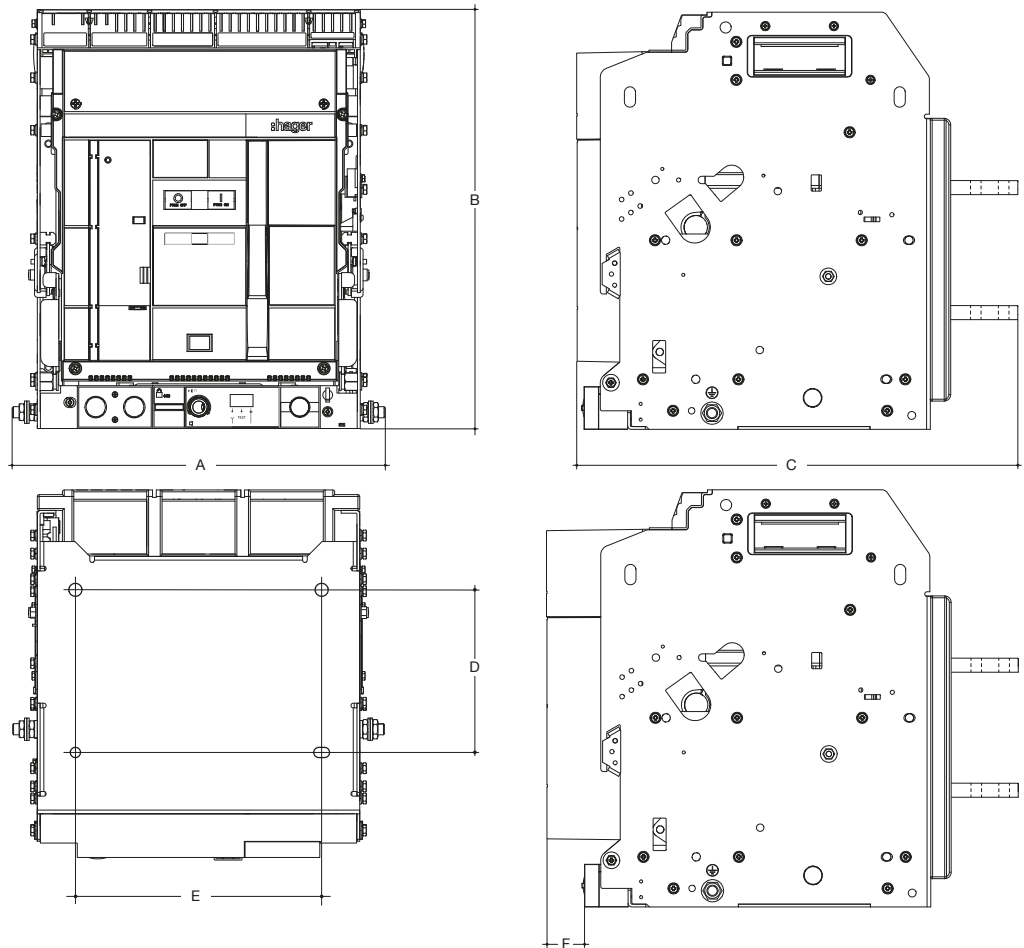

Dimensions

**Drawout version HW6**

To install a drawout HW6 circuit breaker, comply with the following dimensions for mounting:

Dimensions (max. value in mm)	HW6	
	3 poles	4 poles
Width A	871	1023
Height B	490	490
Depth C with connections	514	514
Pitch distance D fastening depth	175	175
Pitch distance E fastening width	158	410
Protrusion F circuit breaker	in the Test position	40
	in the Disconnected position	56

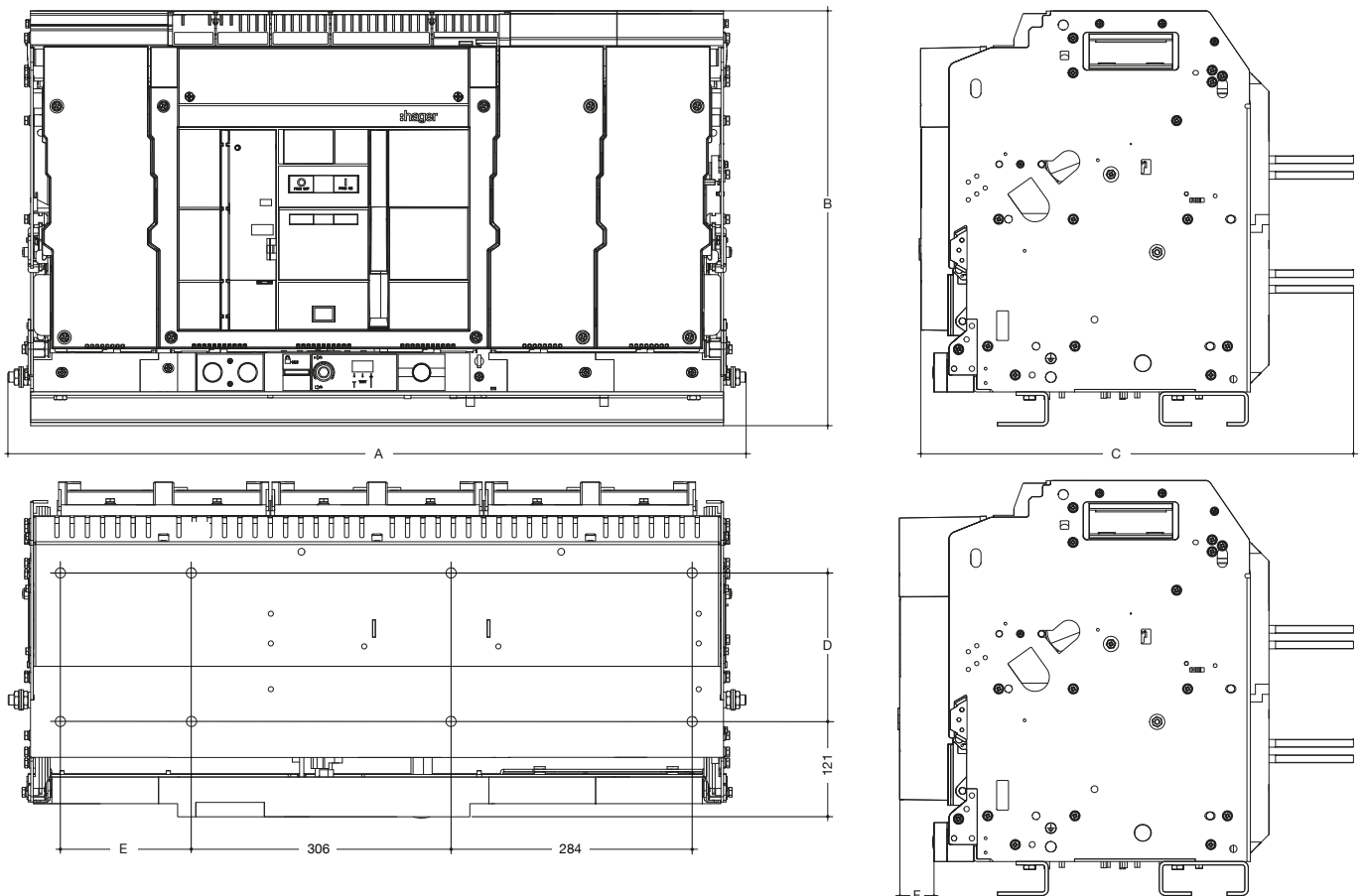

**HW1 rear horizontal RC connections**

For fixed or drawout 3-pole or 4-pole version

Rear view

Side view

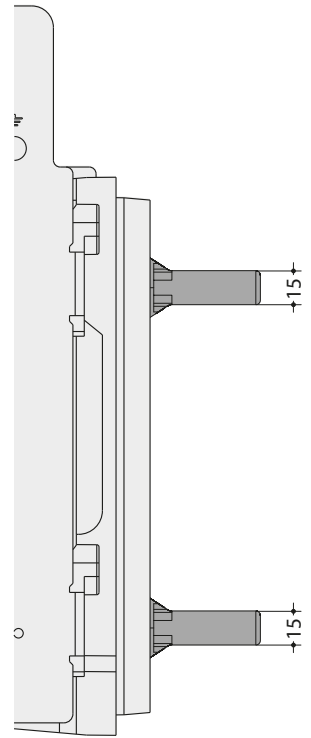
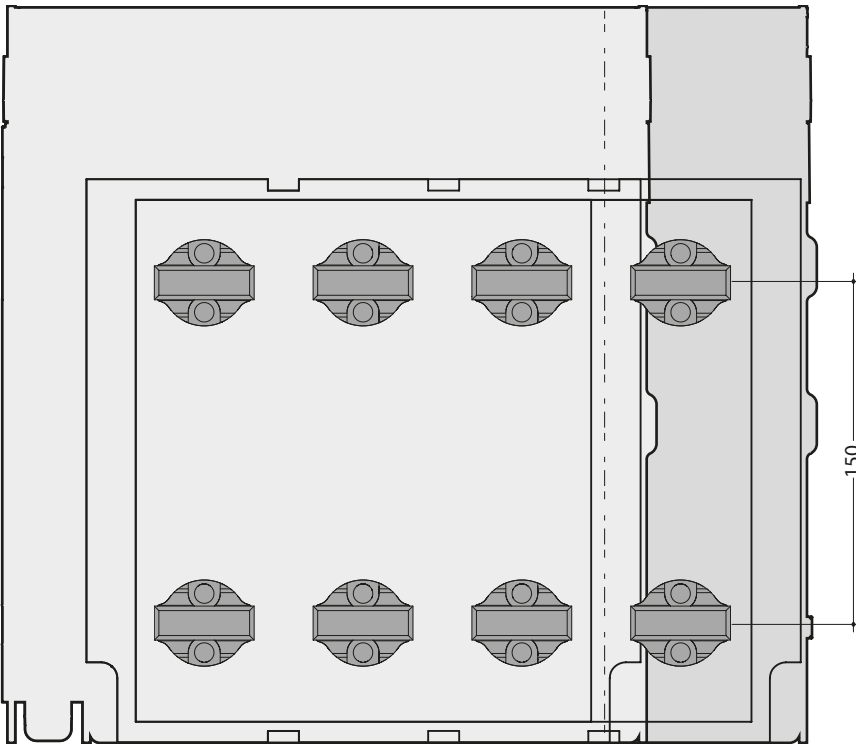

Top view

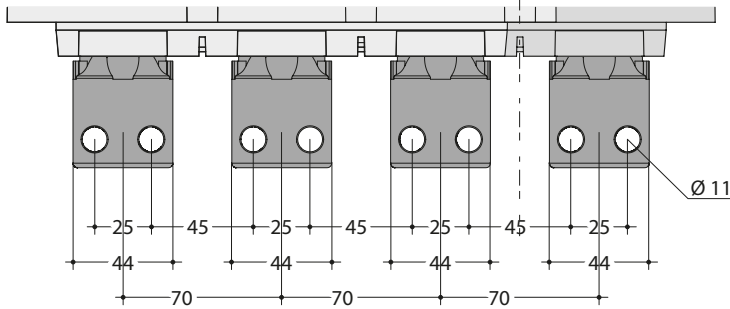

The illustration above shows a drawout version.  
The dimensions given are valid for the fixed and drawout versions.

### HW1 rear horizontal RC connections

With SP spreaders for fixed or drawout 3-pole circuit breakers

Rear view

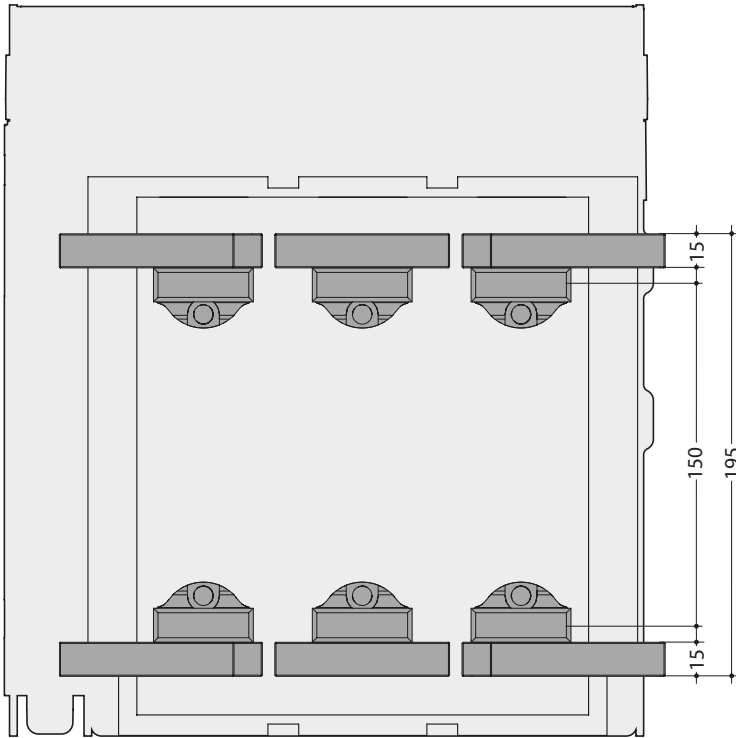

Side view

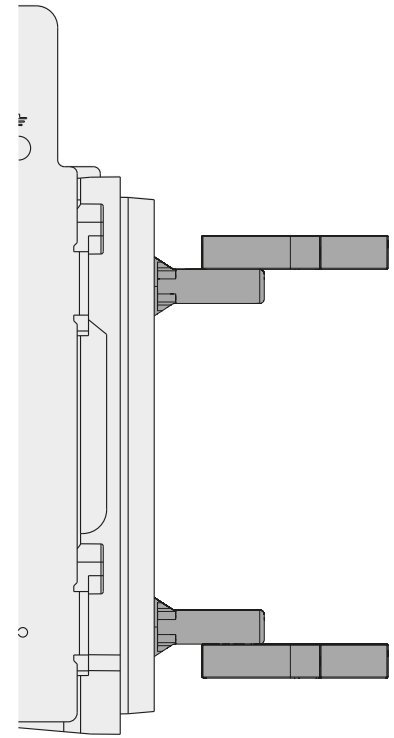

Top view

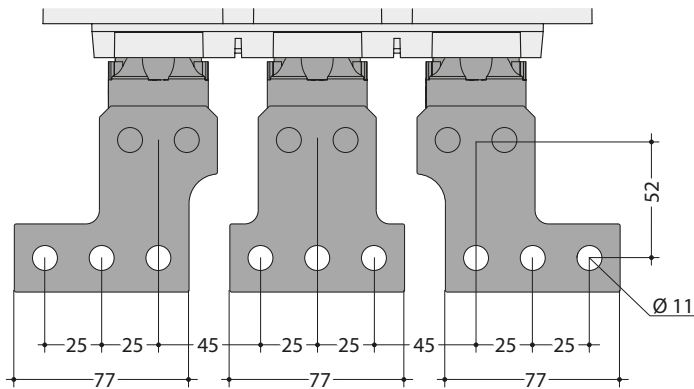

The illustration above shows a drawout version.  
The dimensions given are valid for the fixed and drawout versions.

### HW1 rear horizontal RC connections

With SP spreaders for fixed or drawout 4-pole circuit breakers

Rear view

Side view

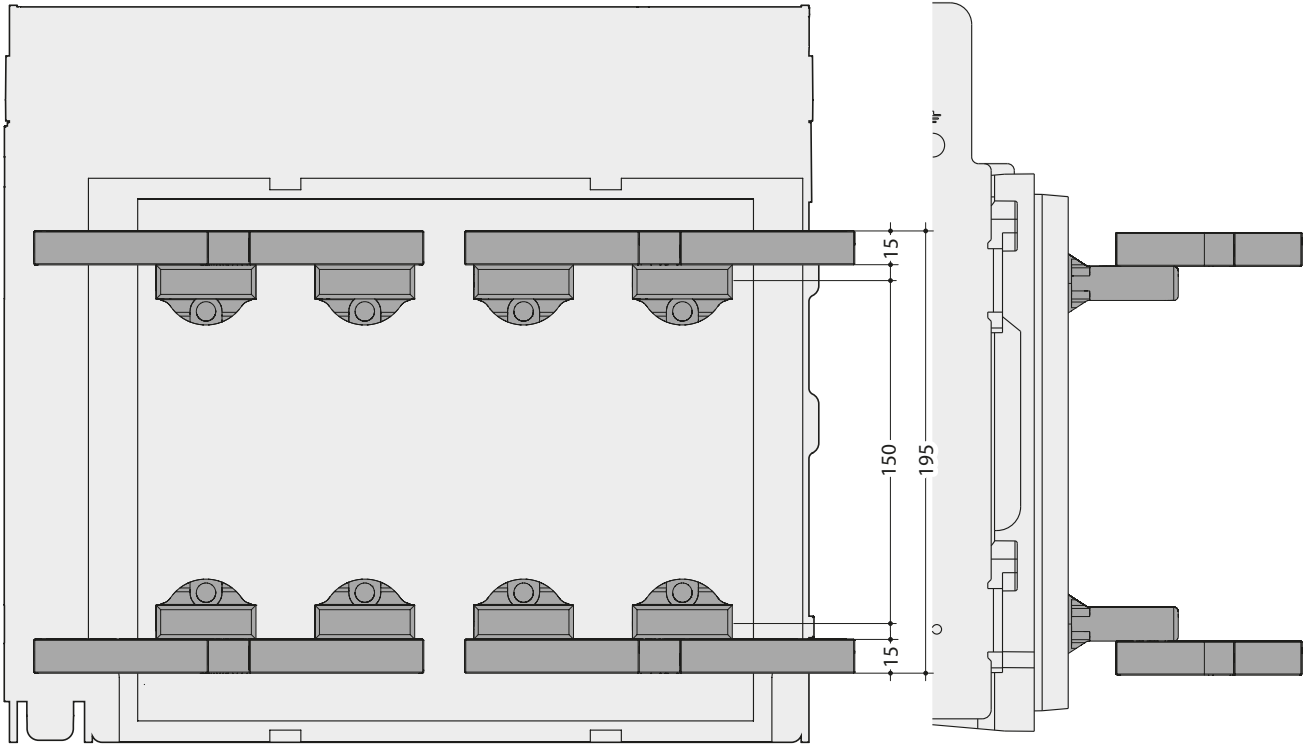

Top view

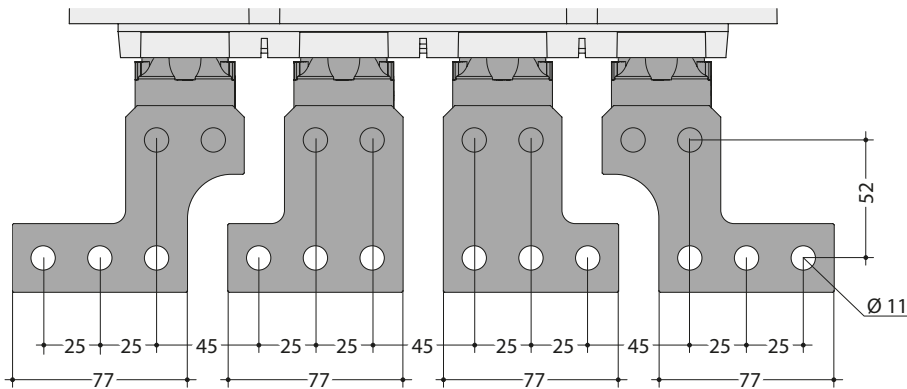

The illustration above shows a drawout version.  
The dimensions given are valid for the fixed and drawout versions.

**HW1 rear horizontal RC connections**

Long for UNIMES type distribution board for fixed or drawout 3-pole or 4-pole circuit breaker

Rear view

Side view

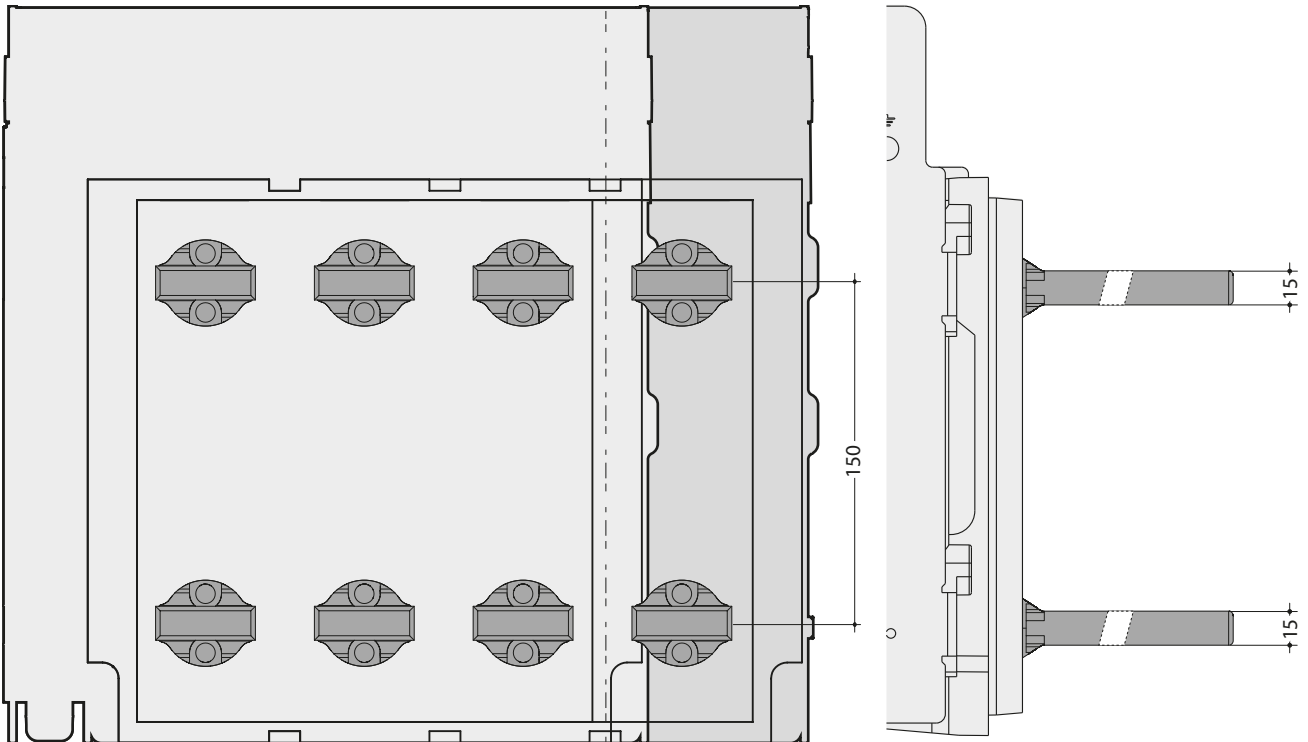

Top view

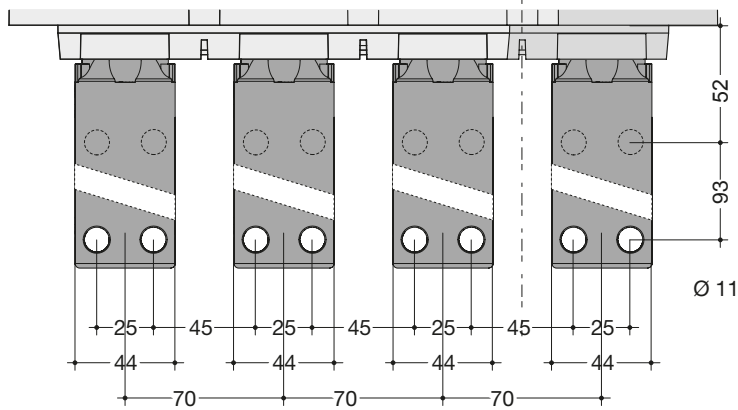

The illustration above shows a drawout version.  
The dimensions given are valid for the fixed and drawout versions.

**HW1 rear vertical RC connections**

For fixed or drawout 3-pole or 4-pole version

Rear view

Side view

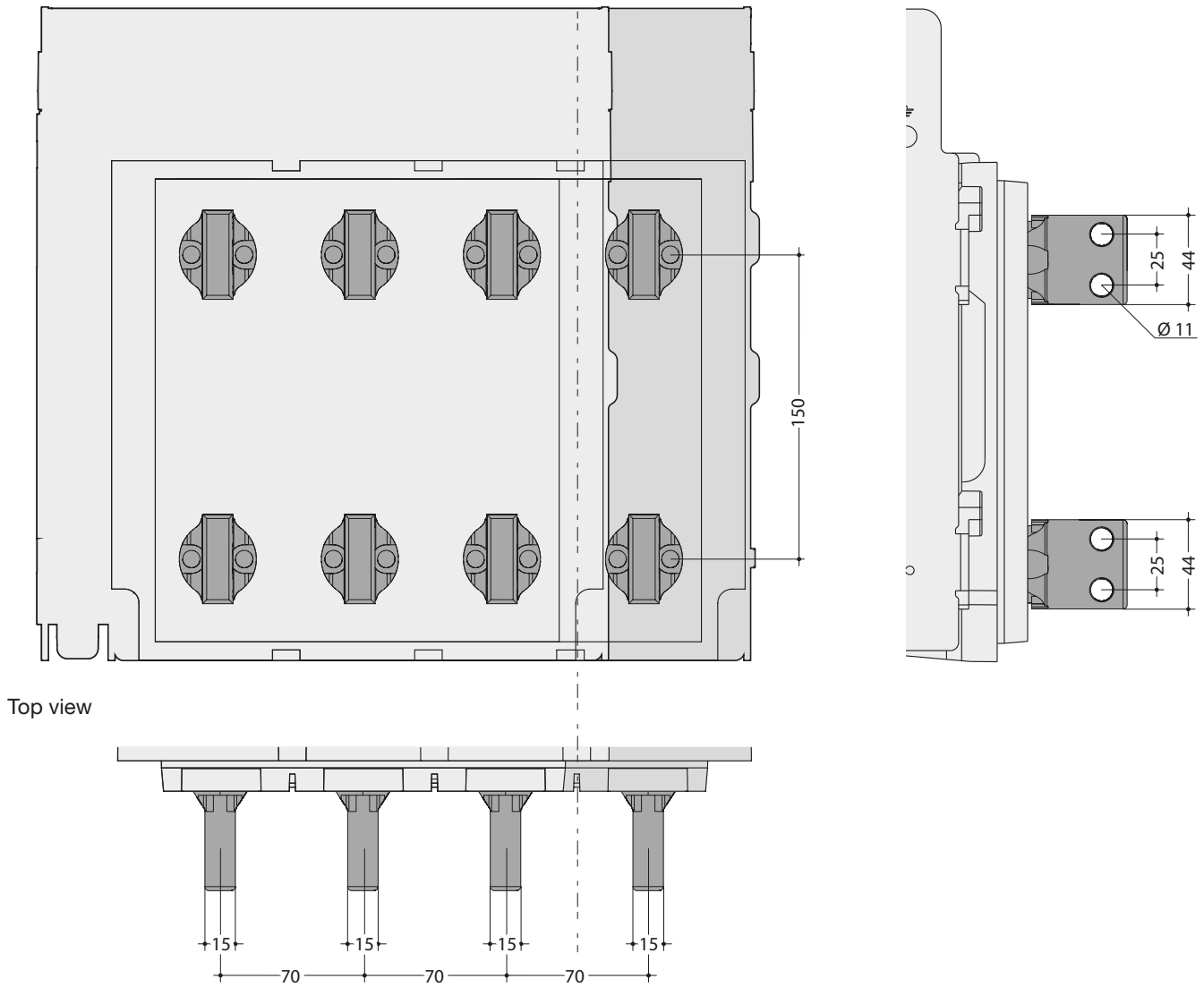

The illustration above shows a drawout version.  
The dimensions given are valid for the fixed and drawout versions.

### HW1 rear vertical RC connections

Long for UNIMES type distribution board for fixed or drawout 3-pole or 4-pole circuit breaker

Rear view

Side view

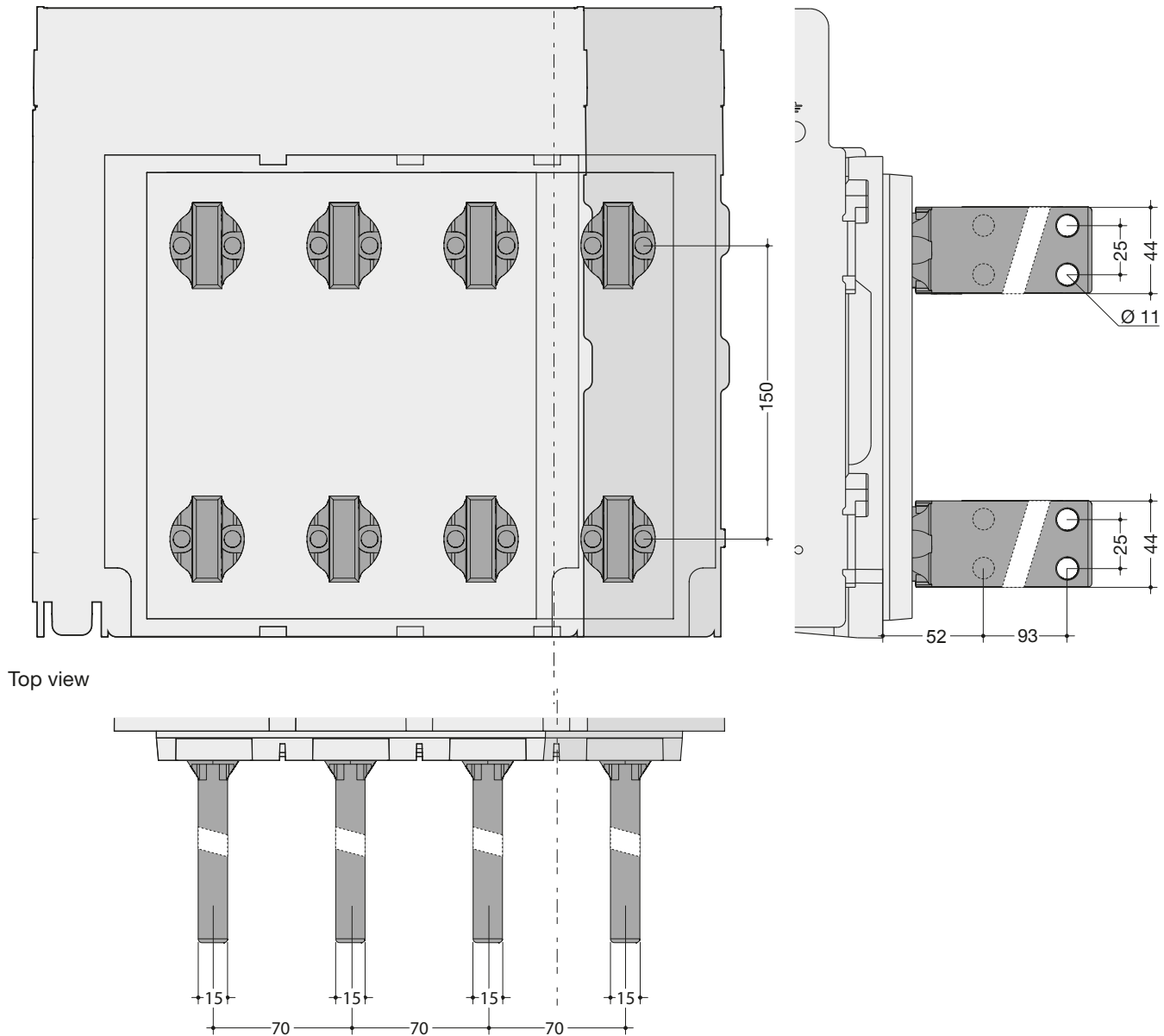

The illustration above shows a drawout version.  
The dimensions given are valid for the fixed and drawout versions.



### HW1 FC front connections

Front connections for fixed 3-pole or 4-pole circuit breaker

Rear view

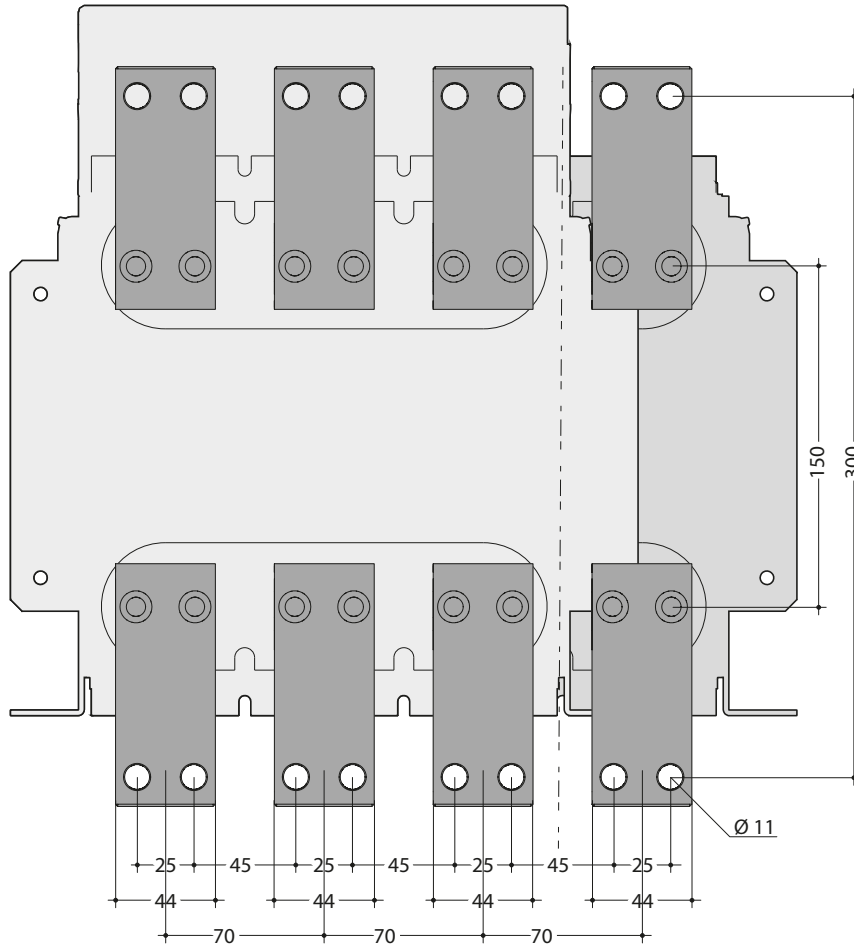

Side view

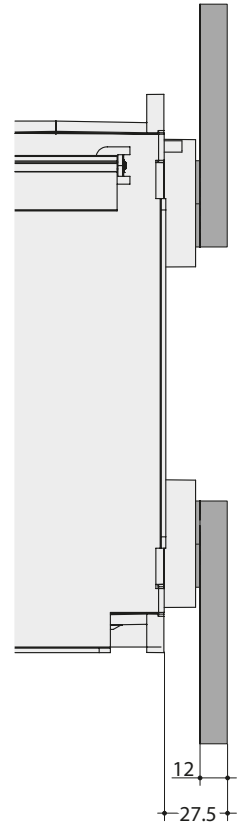

### HW1 FC front connections

For drawout 3-pole or 4-pole circuit breaker

Rear view

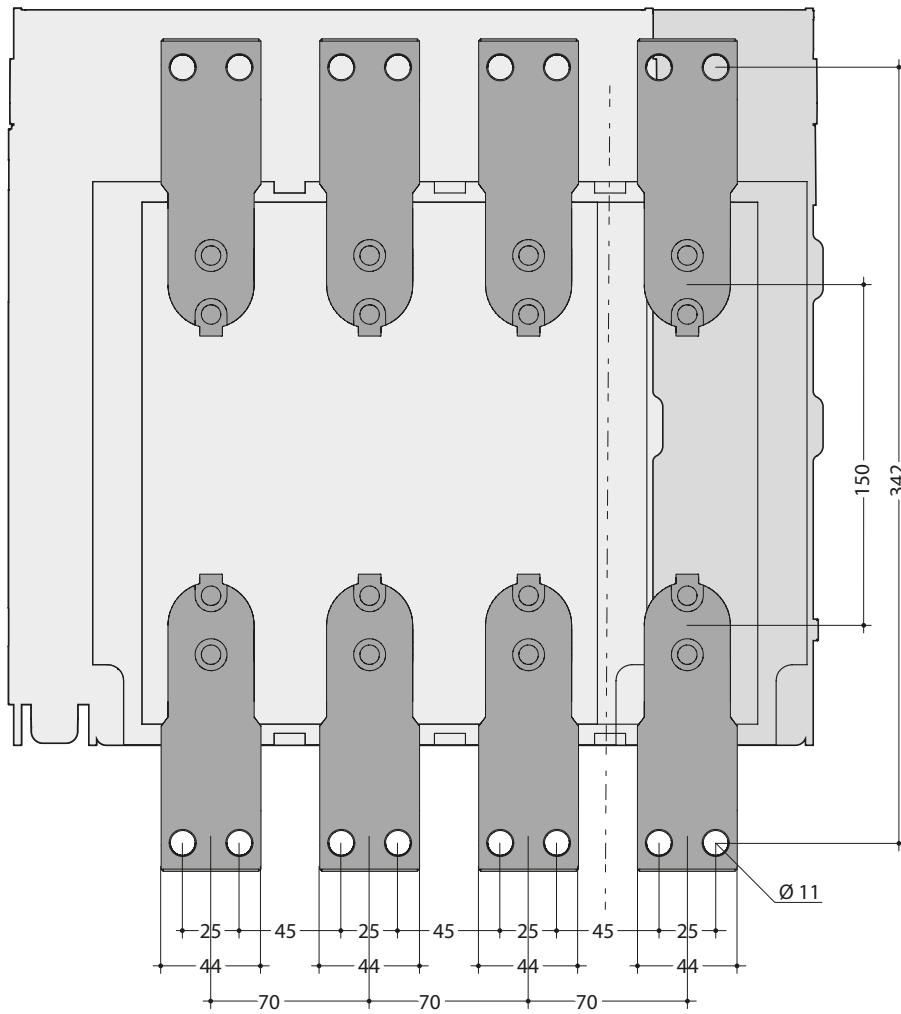

Side view

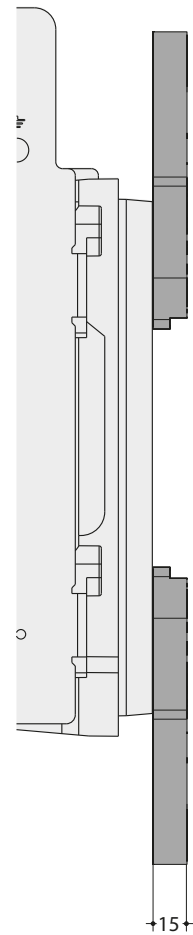

**HW1 FC front connections**

For drawout 3-pole or 4-pole circuit breaker with short terminal extensions in bottom position

Rear view

Side view

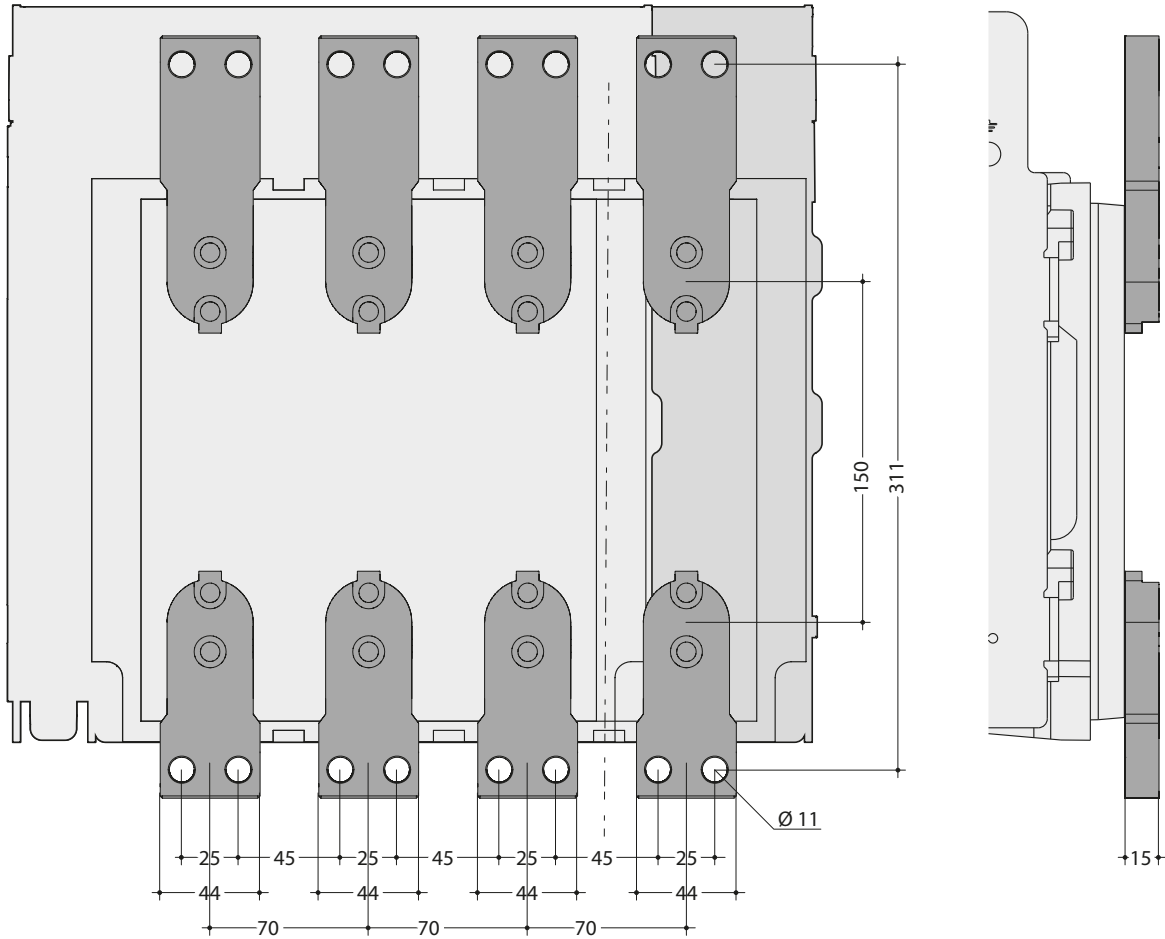

**HW1 FC front connections with SP spreaders**

For fixed 3 pole circuit breaker

Rear view

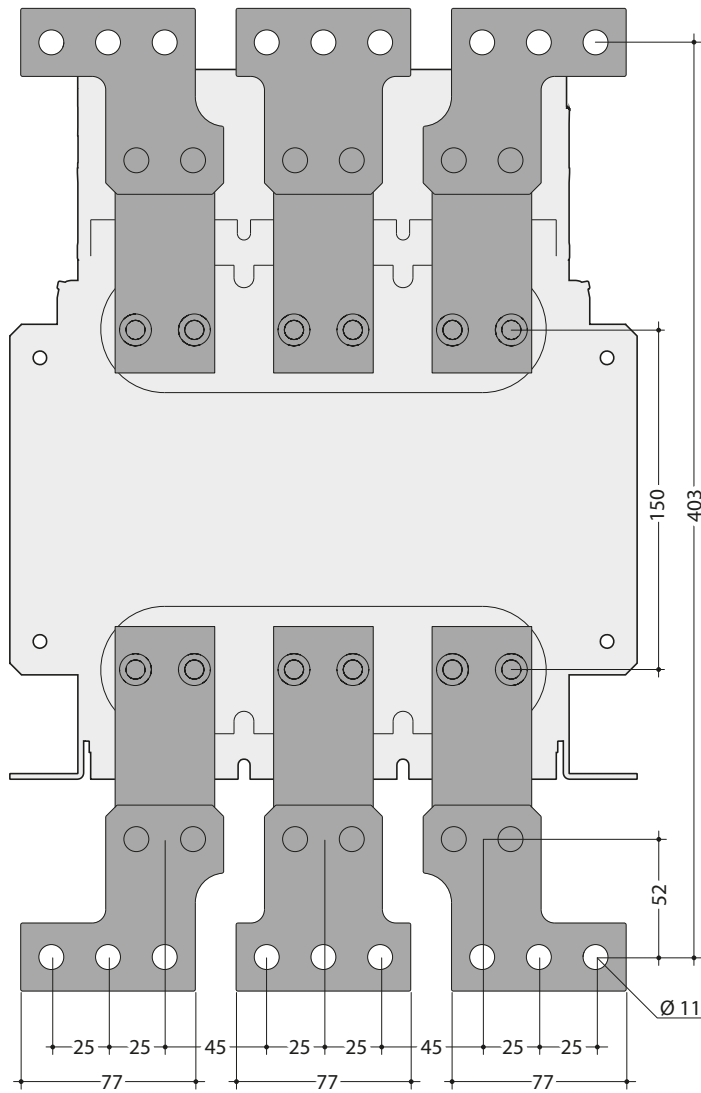

Side view

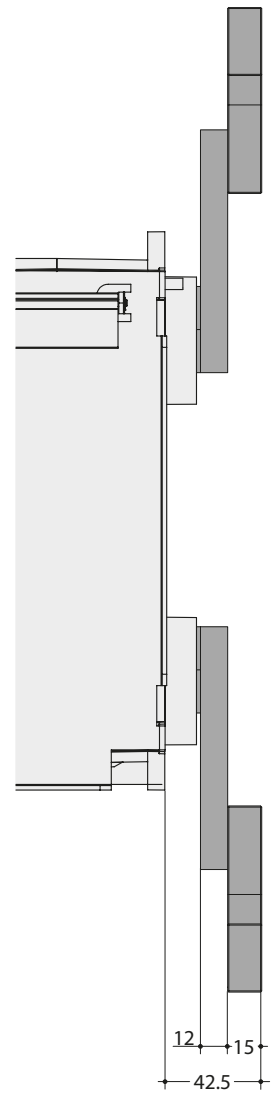

### HW1 FC front connections with SP spreaders

For fixed 4 pole circuit breaker

Rear view

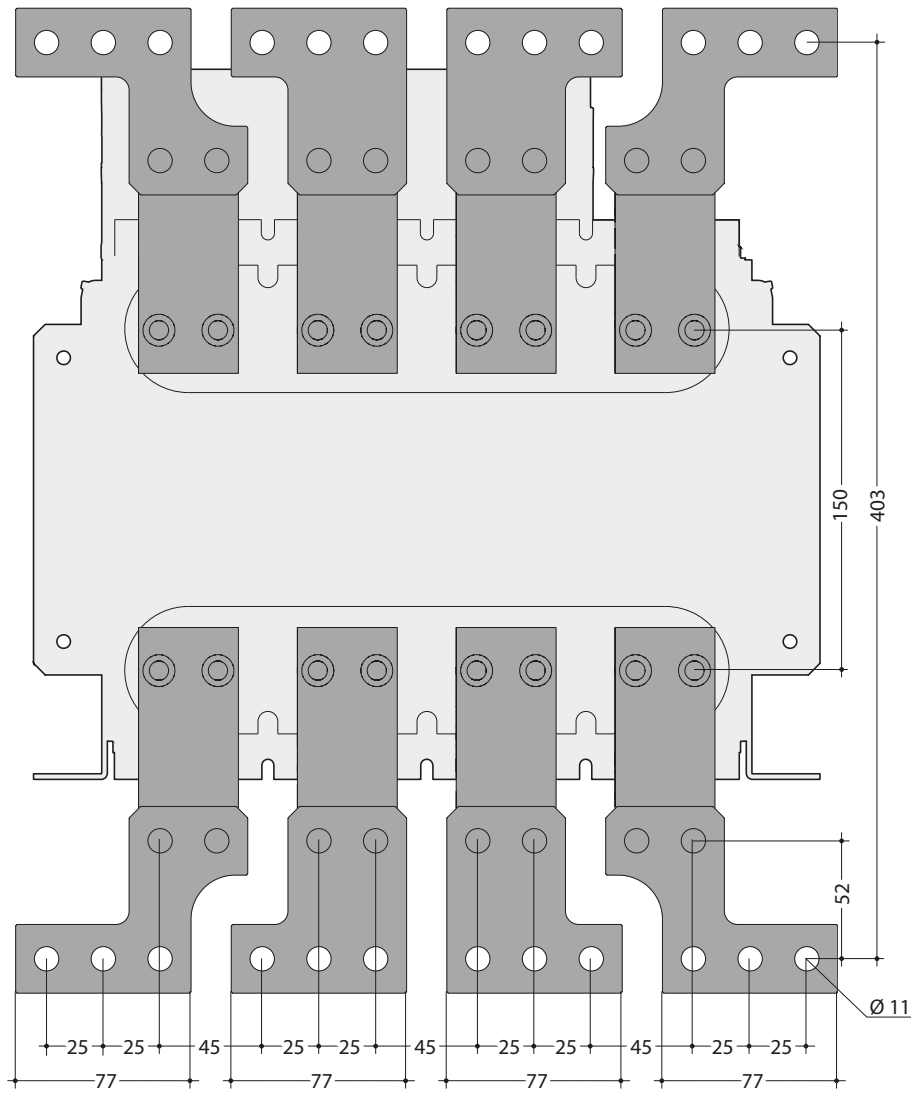

Side view

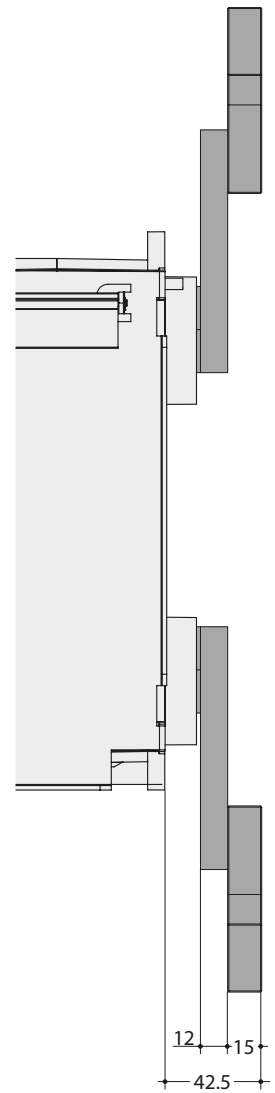

Dimensions

**HW1 FC front connections with SP spreaders**

For drawout 3 pole circuit breaker

Rear view

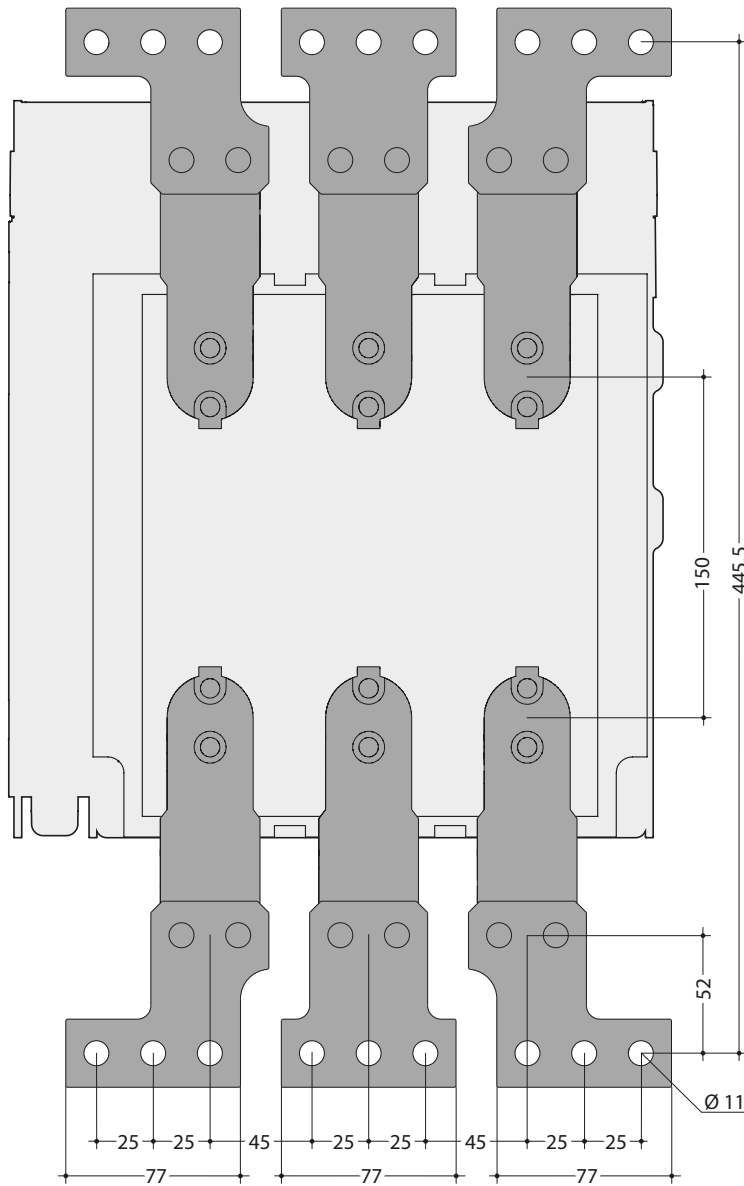

Side view

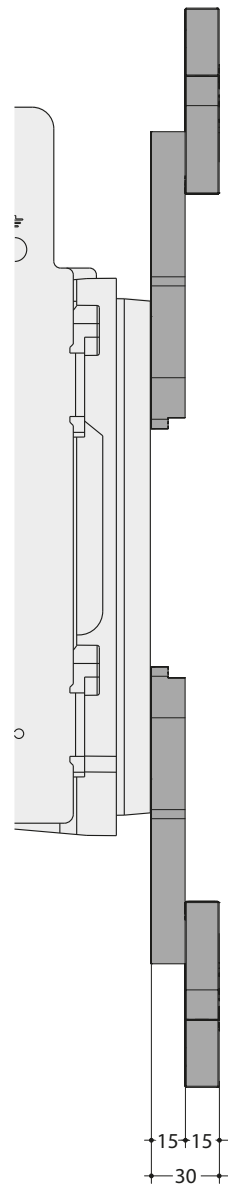

### HW1 FC front connections with SP spreaders

For drawout 4 pole circuit breaker

Rear view

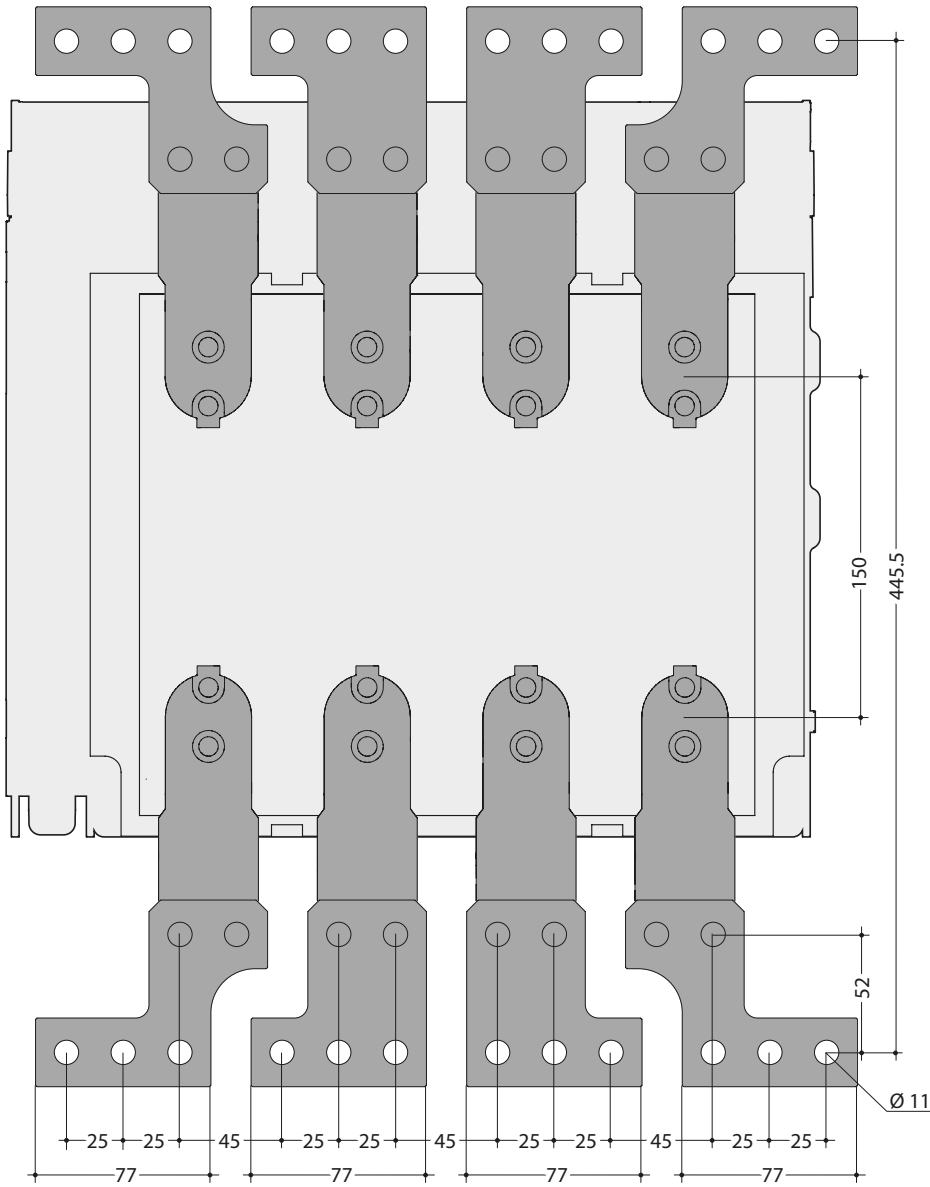

Side view

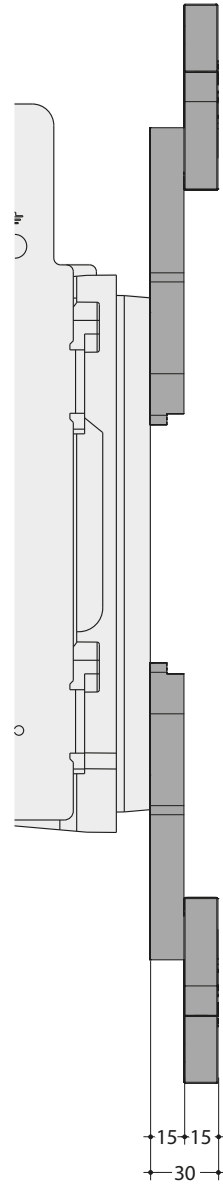

**HW1 FC front connections with SP spreaders**

For drawout 3-pole circuit breaker with short terminal extensions in bottom position

Rear view

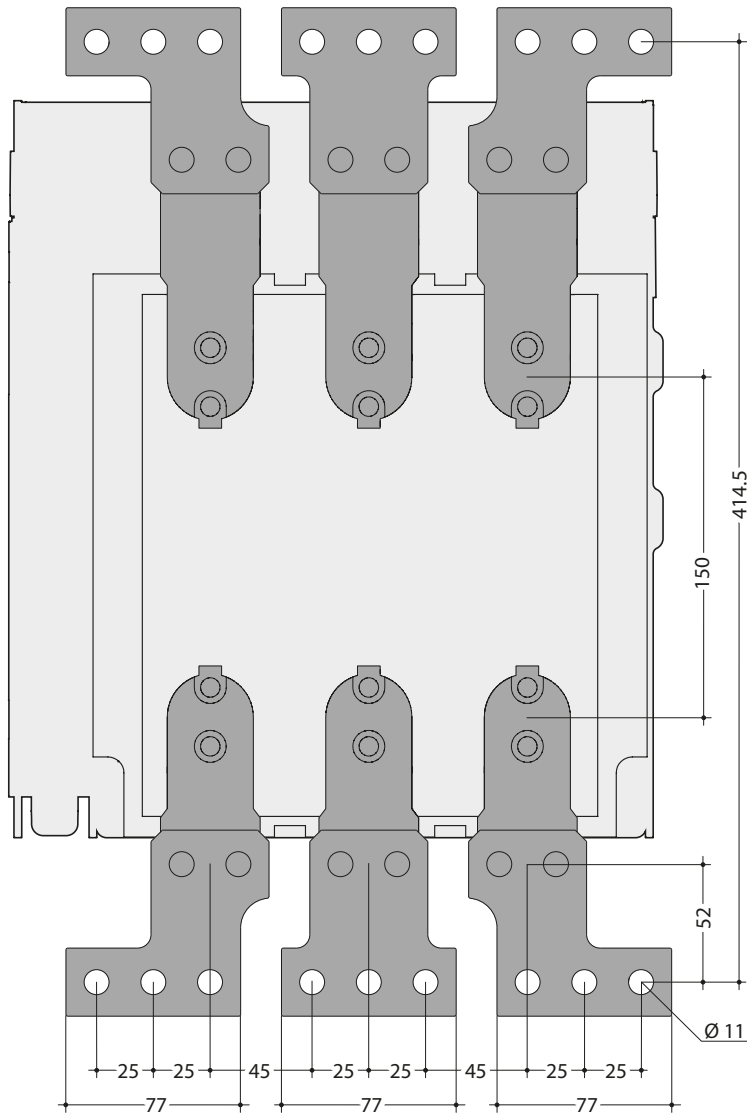

Side view

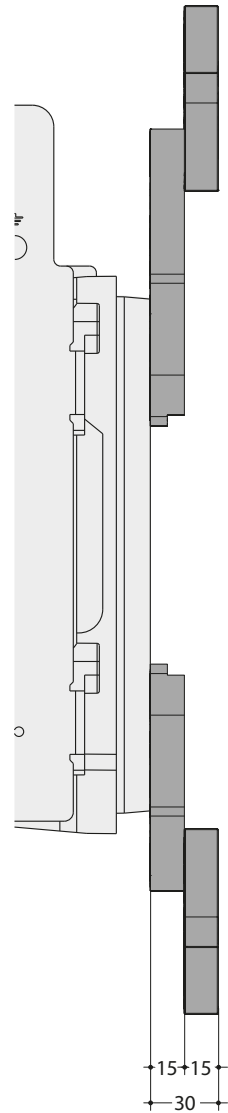



**HW1 FC front connections with SP spreaders**

For drawout 4-pole circuit breaker with short terminal extensions in bottom position

Rear view

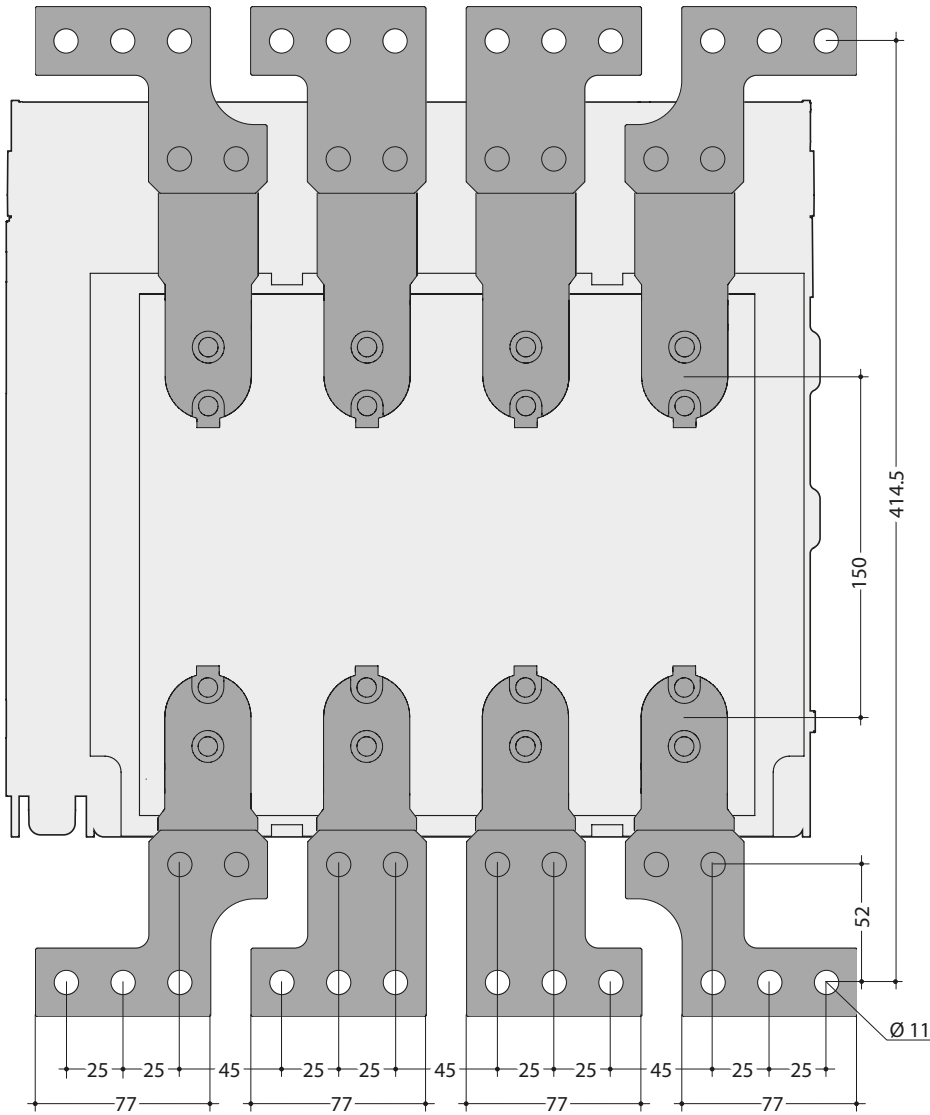

Side view

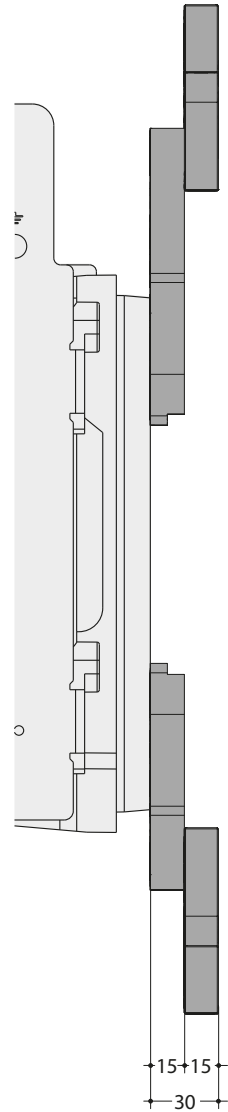

**HW1 FC front connections with VCA vertical connectors**

In front for fixed 3- or 4-pole circuit breaker

Rear view

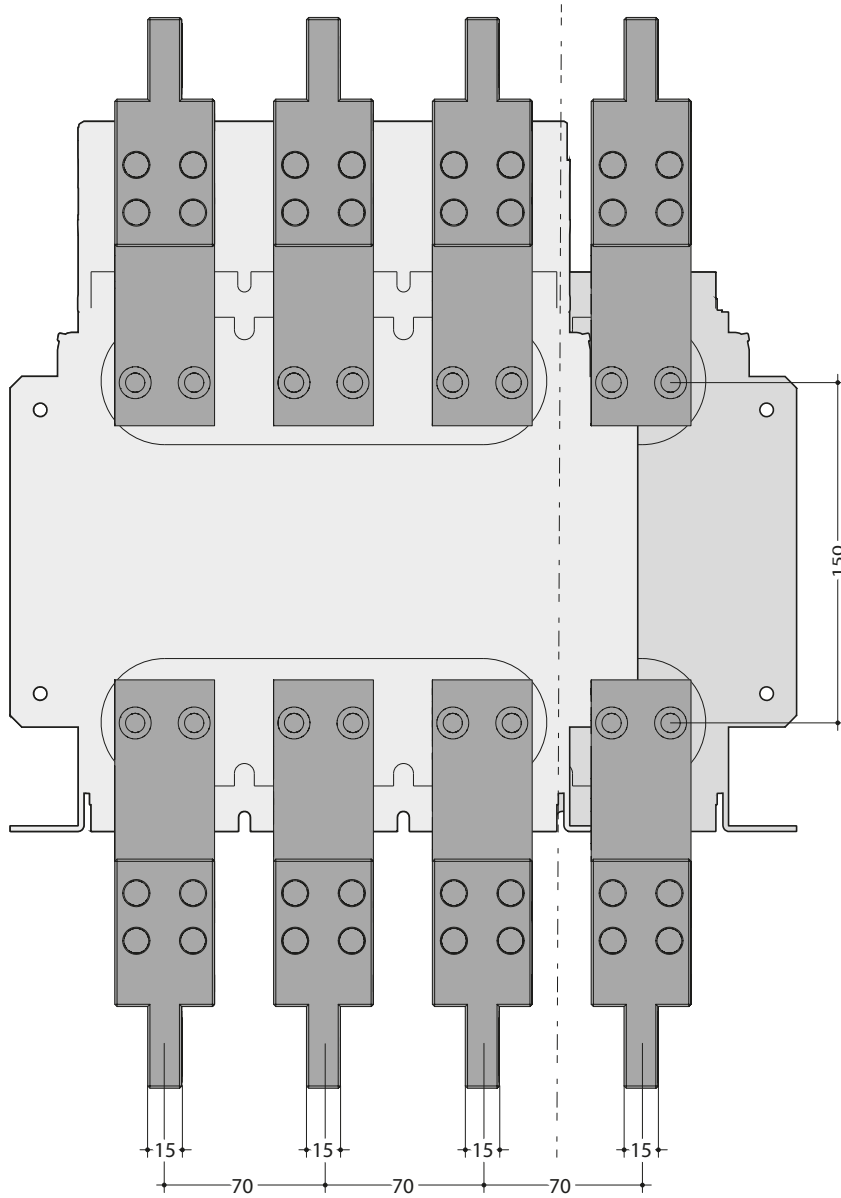

Side view

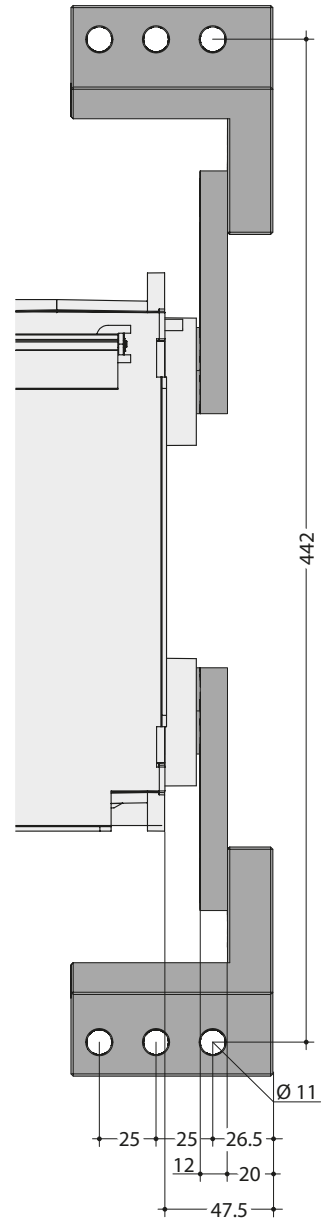

**HW1 FC front connections with VCA vertical connectors**

At rear for fixed 3- or 4-pole circuit breaker

Rear view

Side view

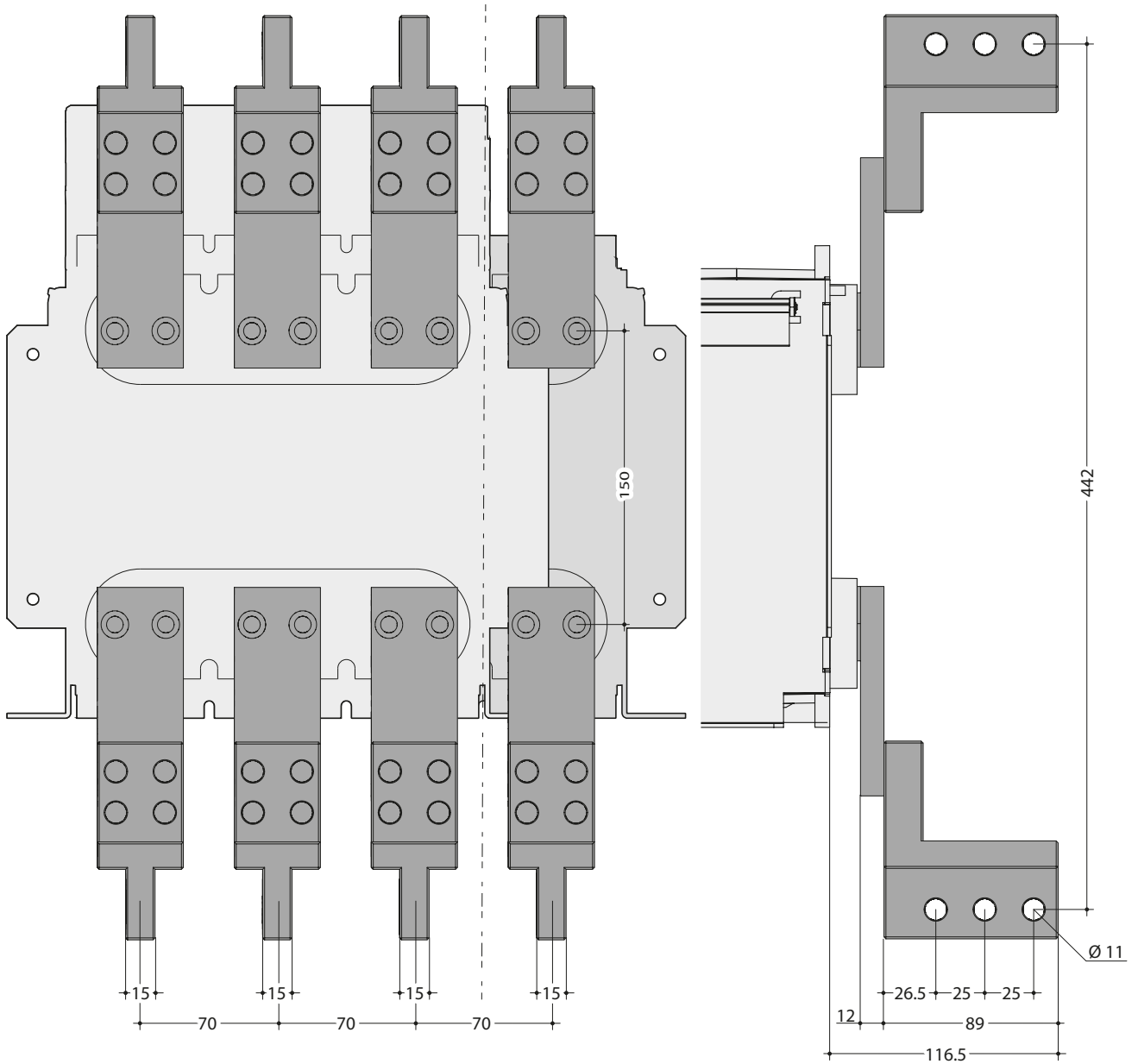

Dimensions

### HW1 FC front connections with VCA vertical connectors

In front for drawout 3-pole or 4-pole circuit breaker

Rear view

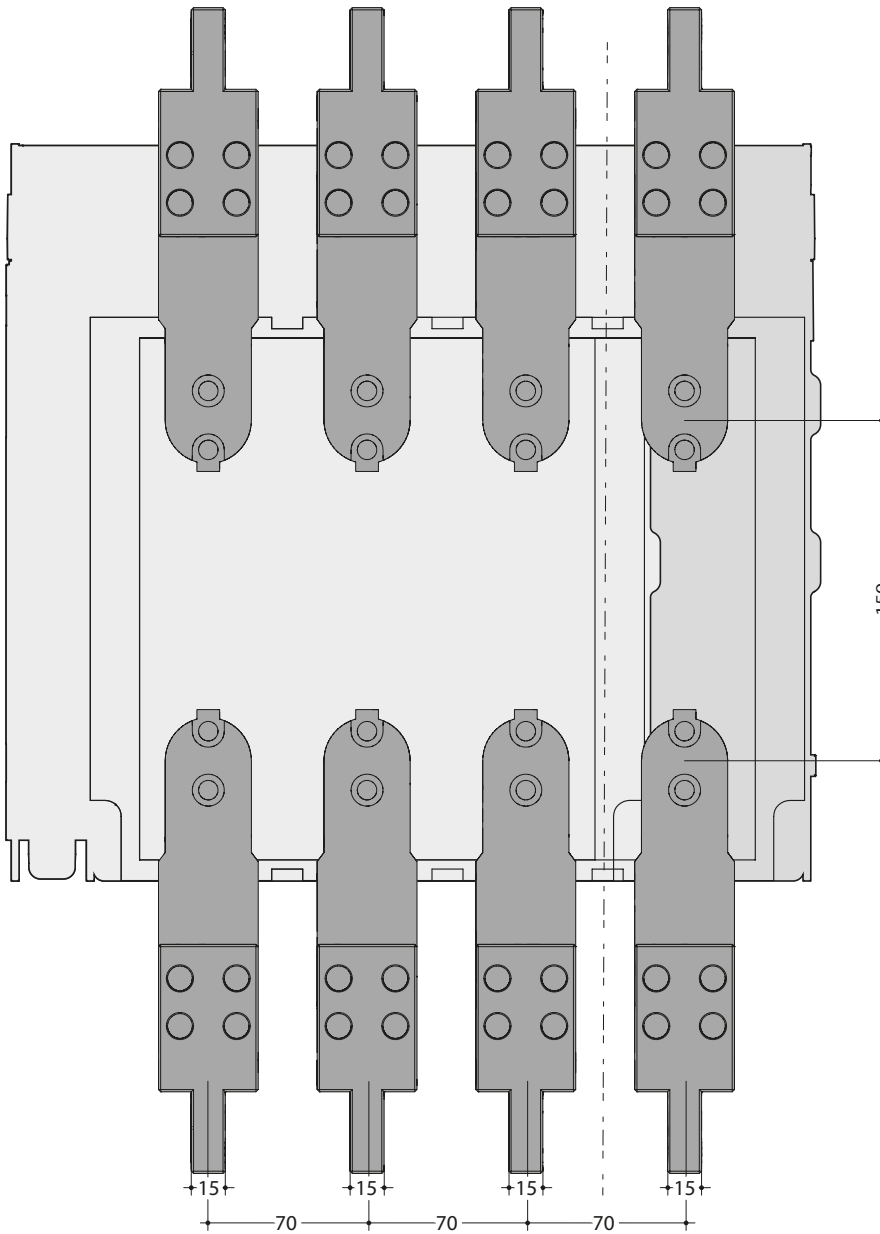

Side view

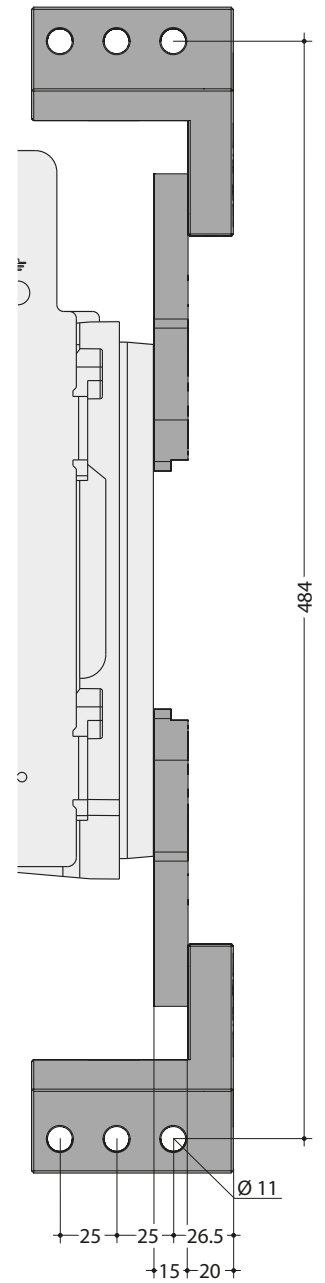

### HW1 FC front connections with VCA vertical connectors

At rear for drawout 3- or 4-pole circuit breaker

Rear view

Side view

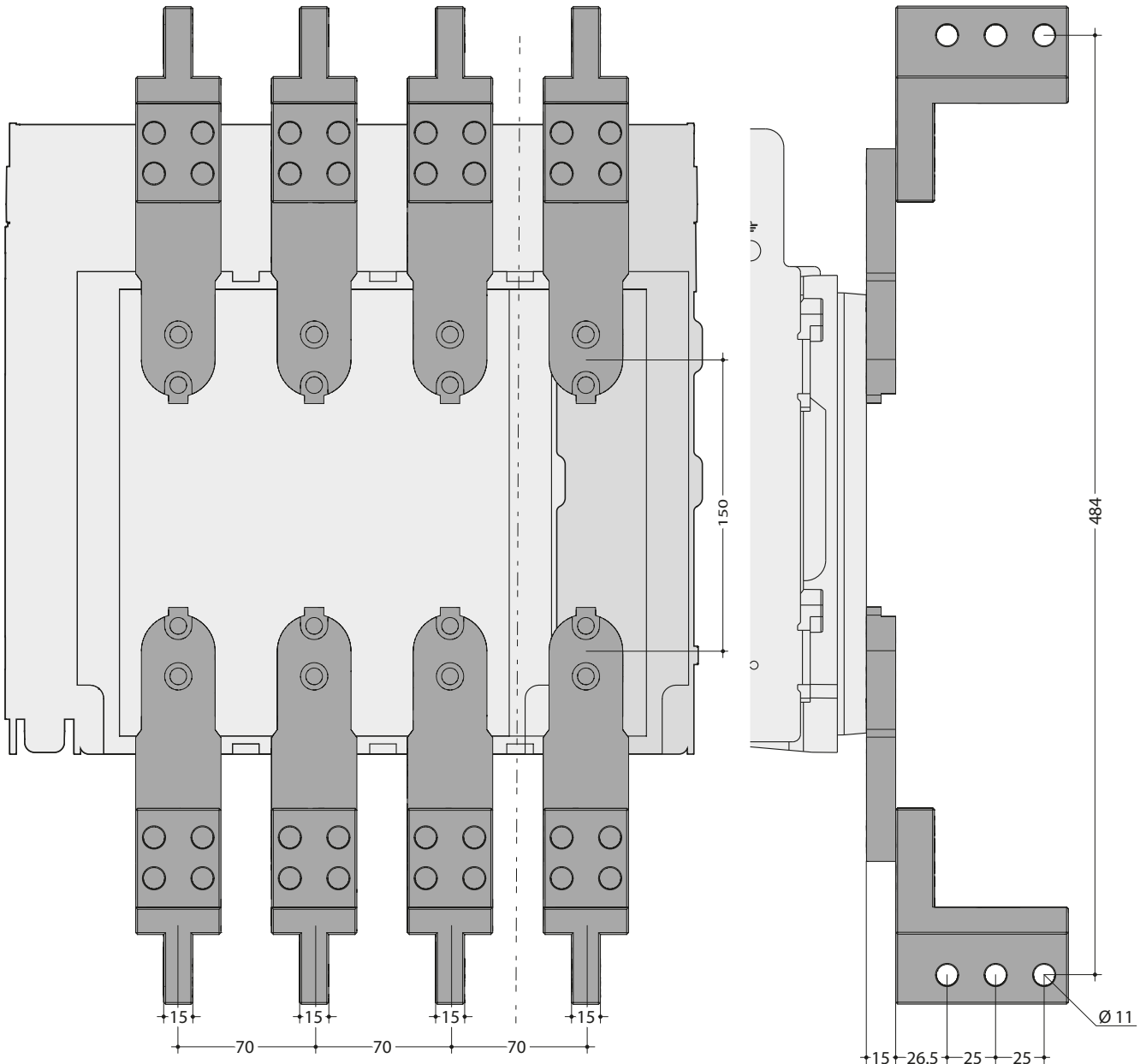

Dimensions

### HW2 rear horizontal RC connections

For fixed or drawout 3-pole or 4-pole version from 630 A to 2500 A

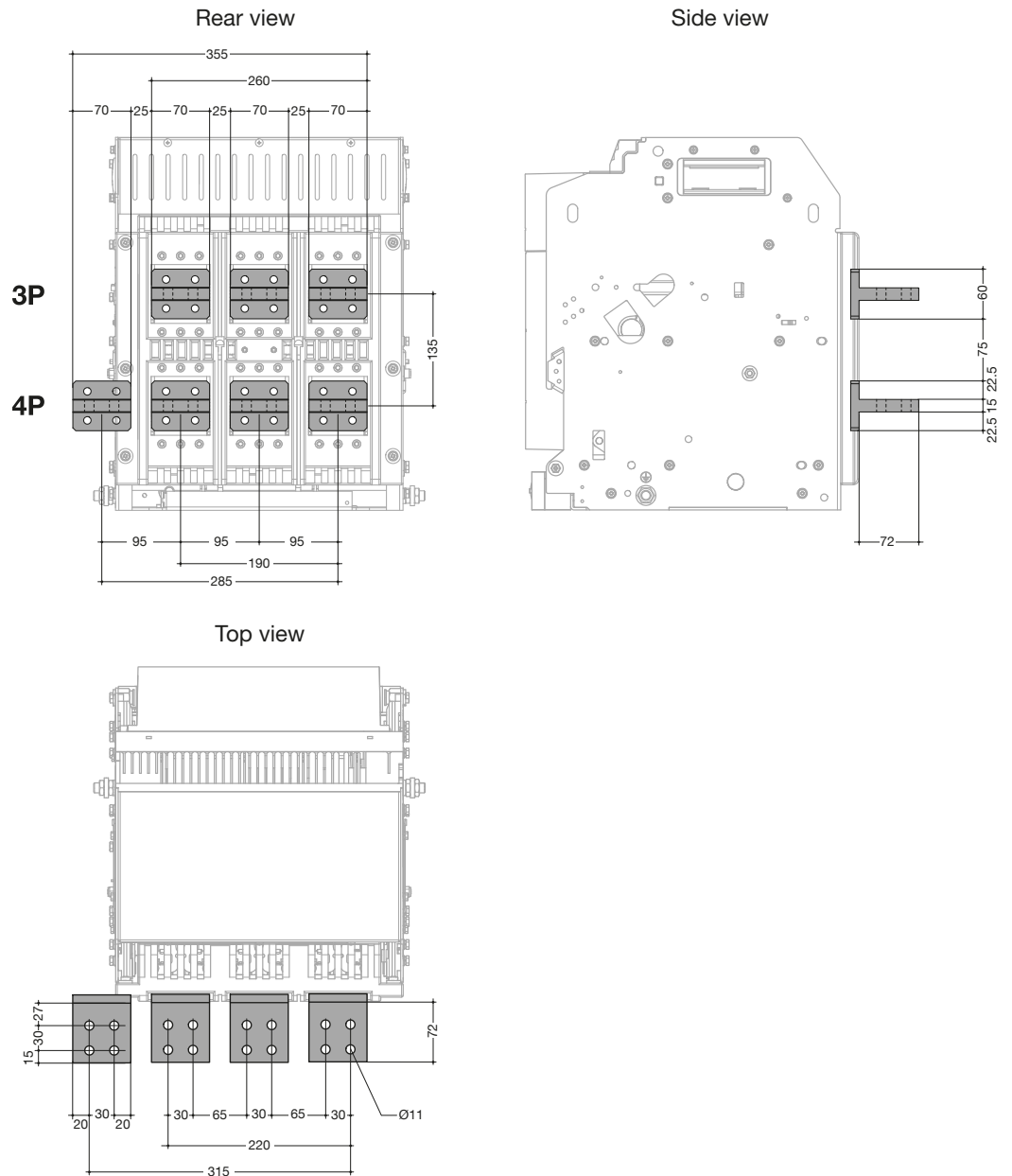

The dimensions given are valid for the fixed and drawout versions.

**Rear horizontal RC HW2 connections for unimes H distribution boards**

For fixed or drawout 3-pole or 4-pole version from 630 A to 2500 A.

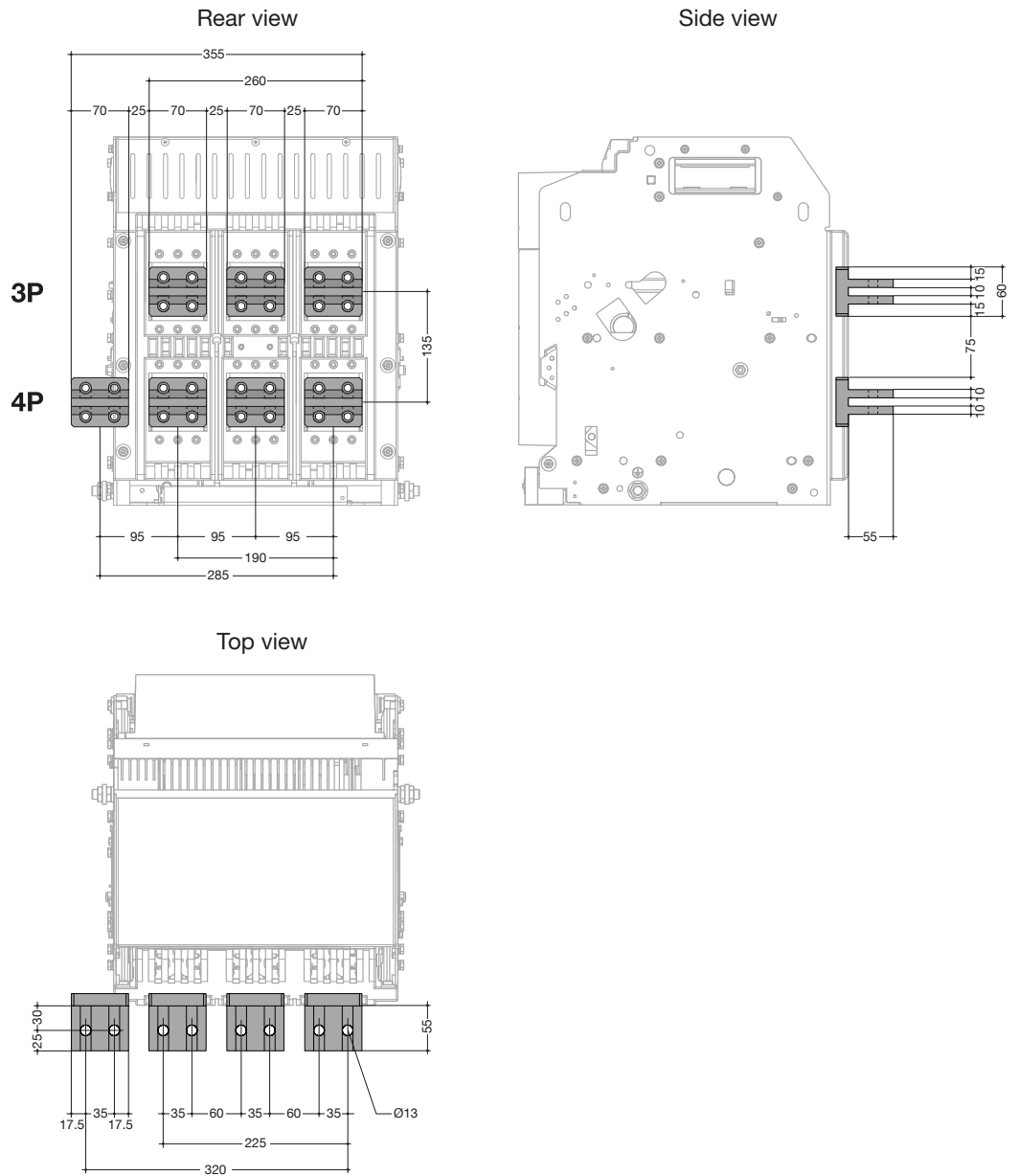

The dimensions given are valid for the fixed and drawout versions.

### HW2 rear vertical RC connections

For fixed or drawout 3-pole or 4-pole version from 630 A to 2500 A.

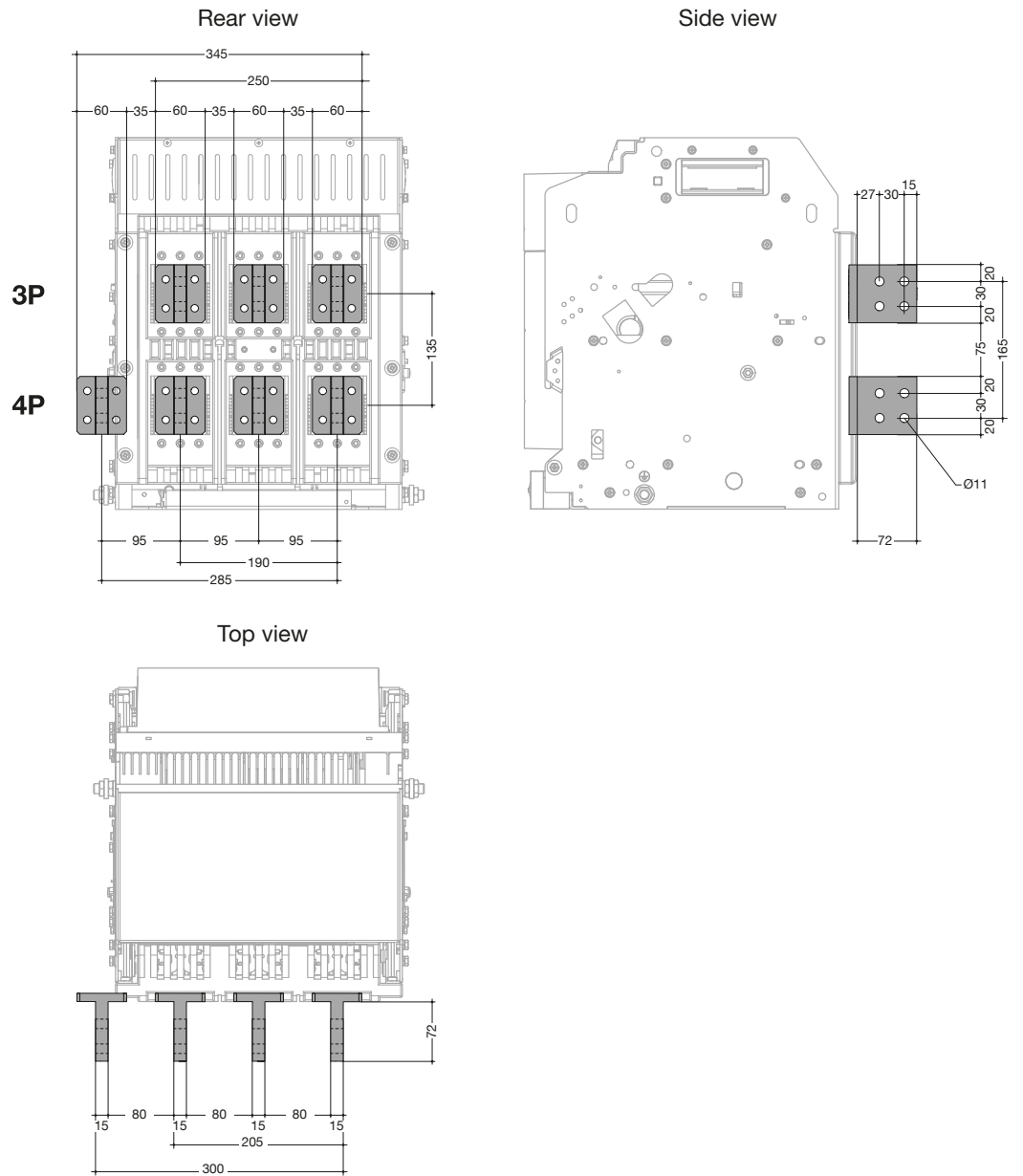

The dimensions given are valid for the fixed and drawout versions.



To connect an HW4 circuit breaker, comply with the following connection dimensions.  
For more information on the installation of the connections, refer to the instruction manual 6LE009122A.

**HW4 rear horizontal RC connections**

For fixed or drawout 3-pole or 4-pole version from 1000A to 2500A.

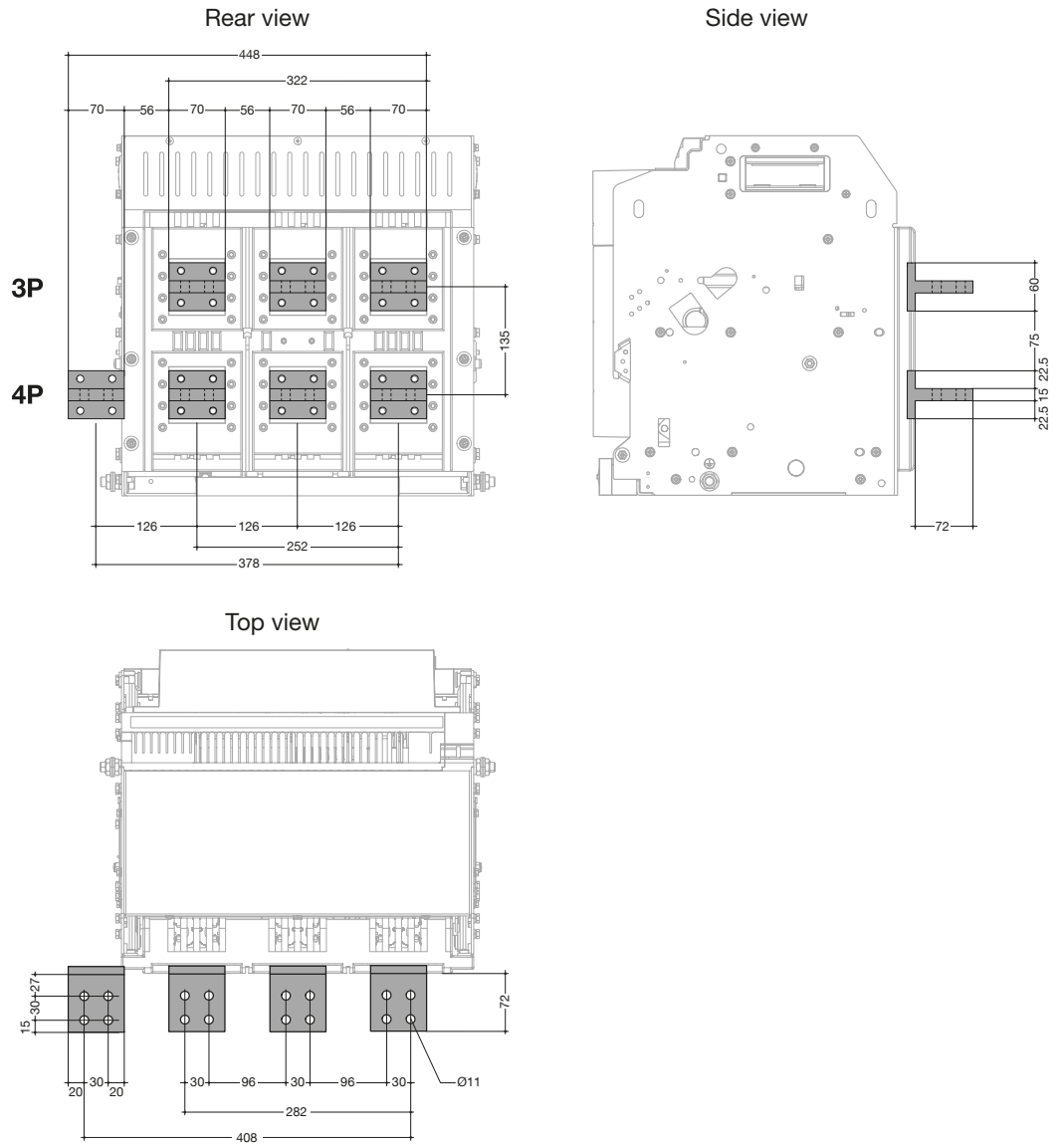

The dimensions given are valid for the fixed and drawout versions.

### HW4 rear vertical RC connections

For fixed or drawout 3-pole or 4-pole version from 1000A to 2500A.

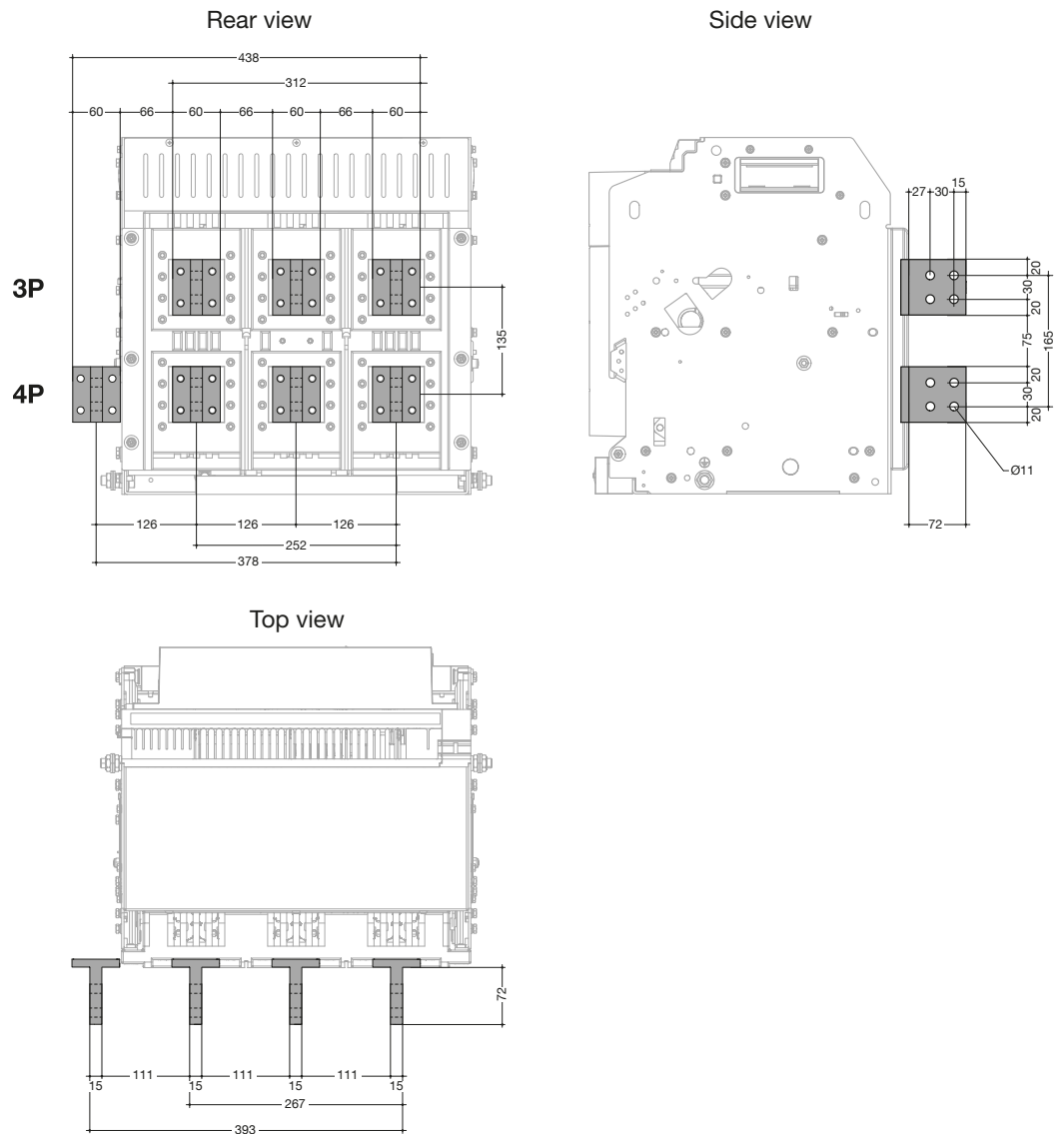

The dimensions given are valid for the fixed and drawout versions.

**HW4 rear horizontal RC connections**

For fixed or drawout 3-pole or 4-pole version from 3200A to 4000A.

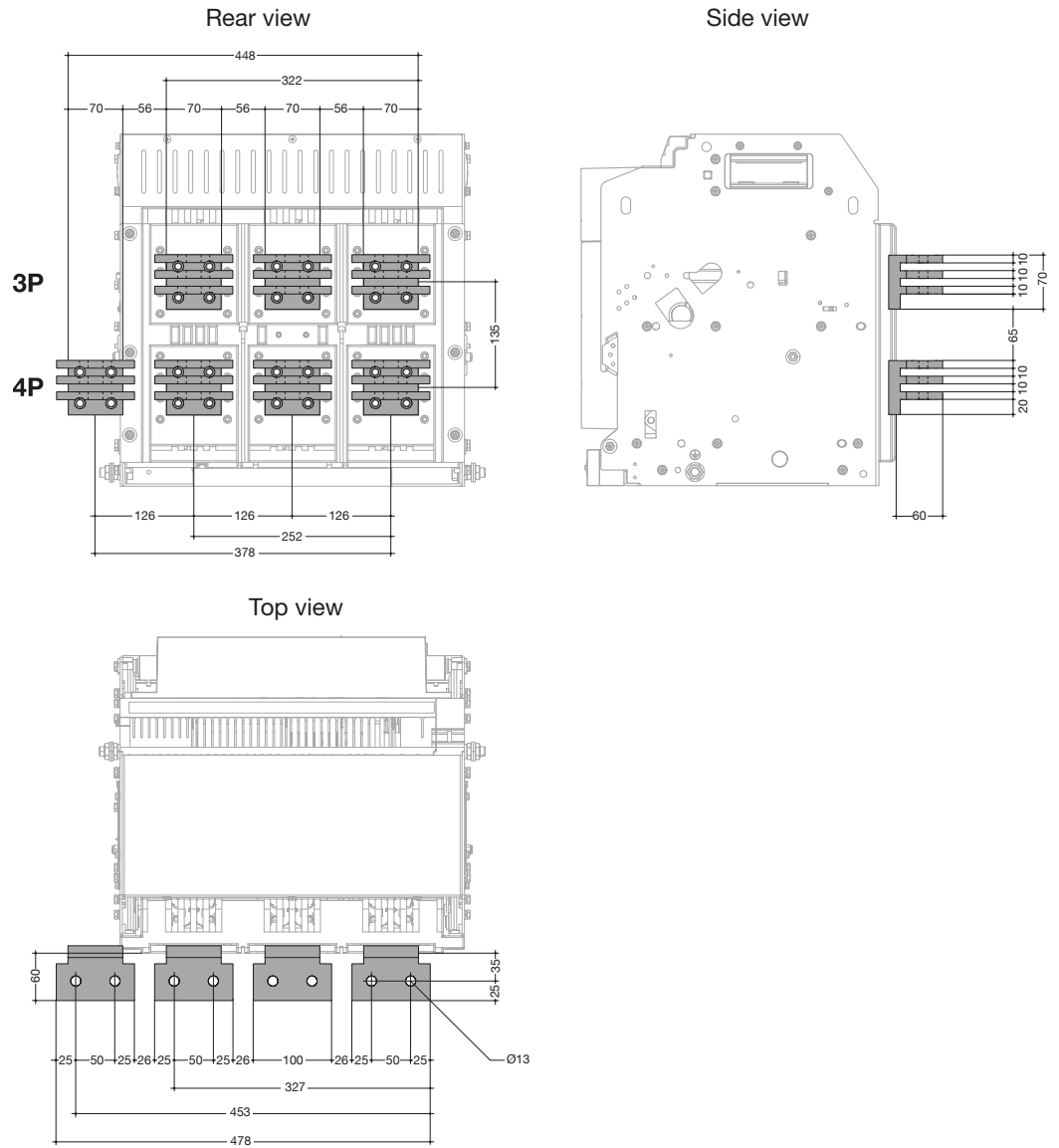

The dimensions given are valid for the fixed and drawout versions.

### HW4 rear vertical RC connections

For fixed or drawout 3-pole or 4-pole version from 3200A to 4000A.

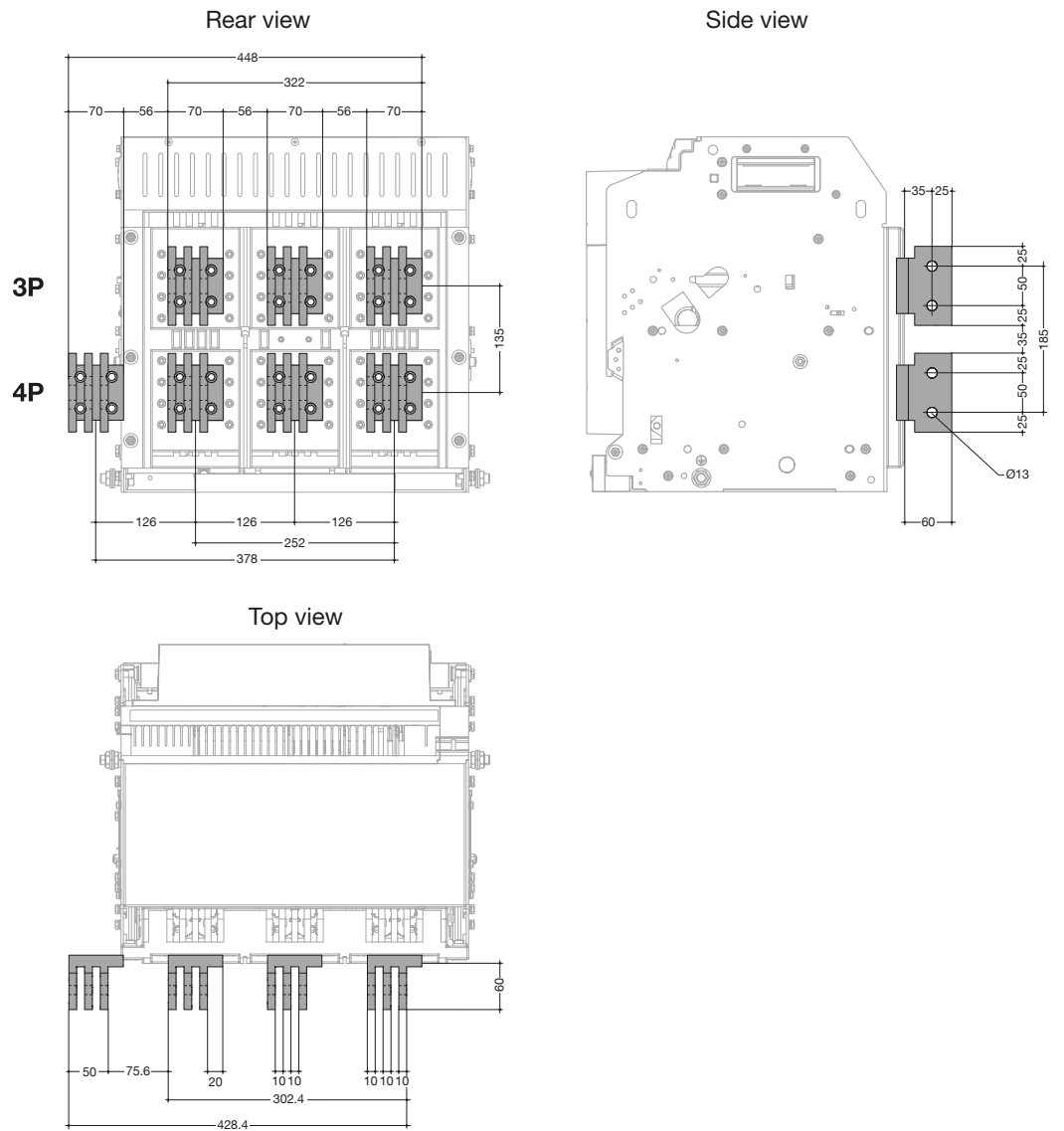

The dimensions given are valid for the fixed and drawout versions.

To connect an HW6 circuit breaker, comply with the following connection dimensions.

**HW6 rear horizontal RC connections**

For fixed or drawout 3-pole from 3200A to 6300A.

Rear view

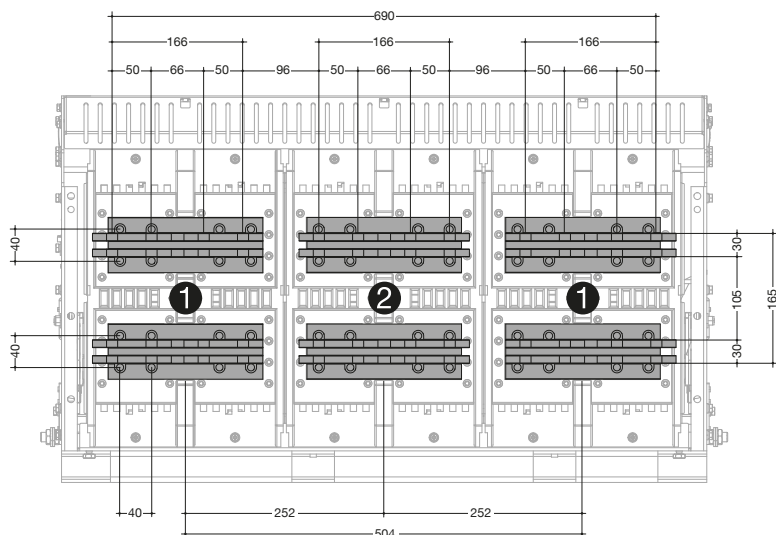

Side view

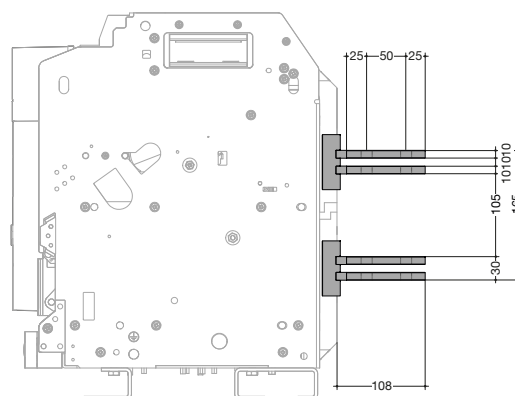

Top view

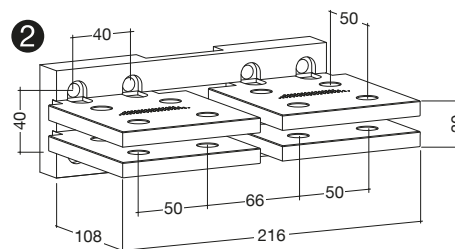
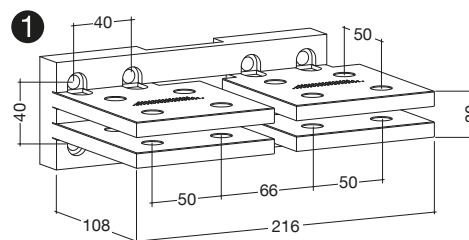
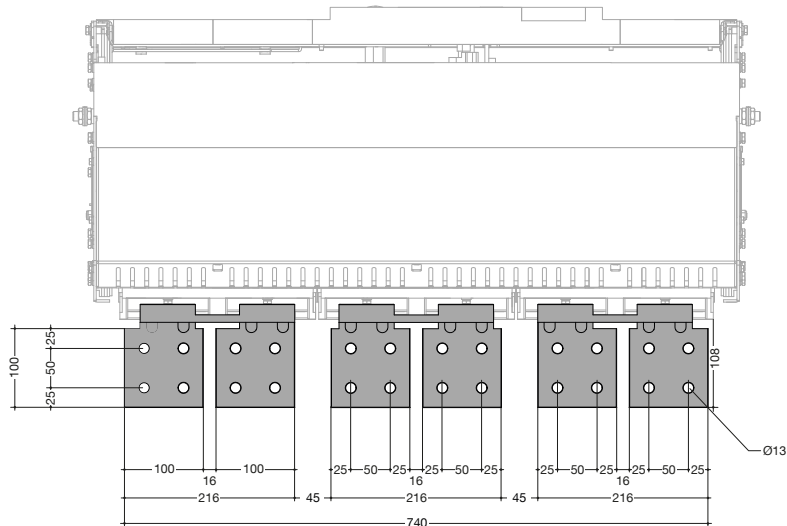

The dimensions given are only valid for the 3-pole fixed and drawout versions.

**HW6 rear horizontal RC connections**

For fixed or drawout 4-pole from 3200A to 6300A.

Rear view

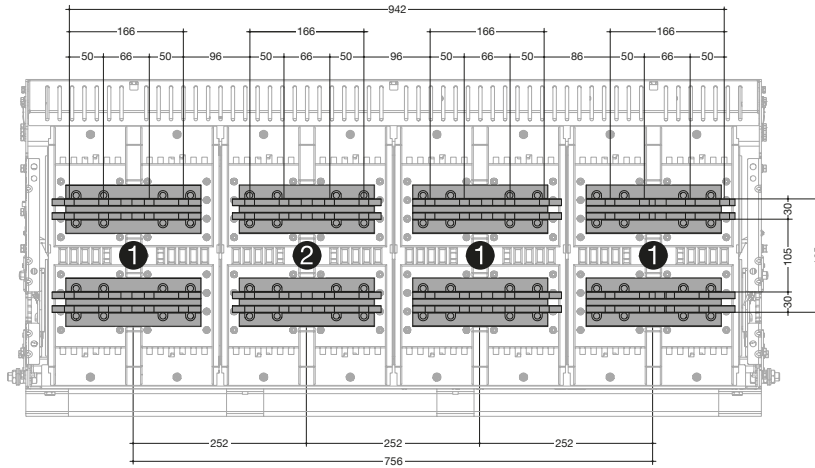

Side view

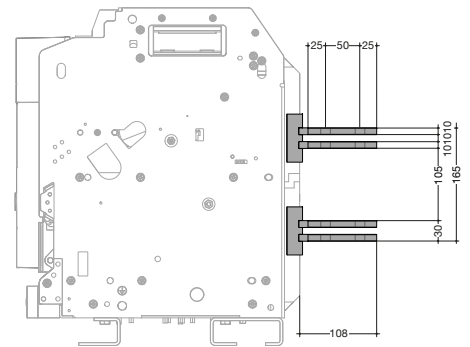

Top view

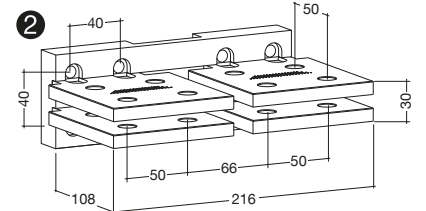
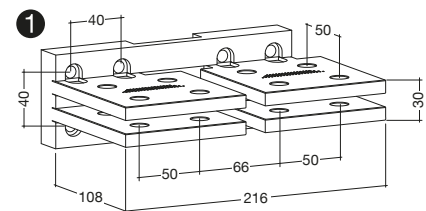
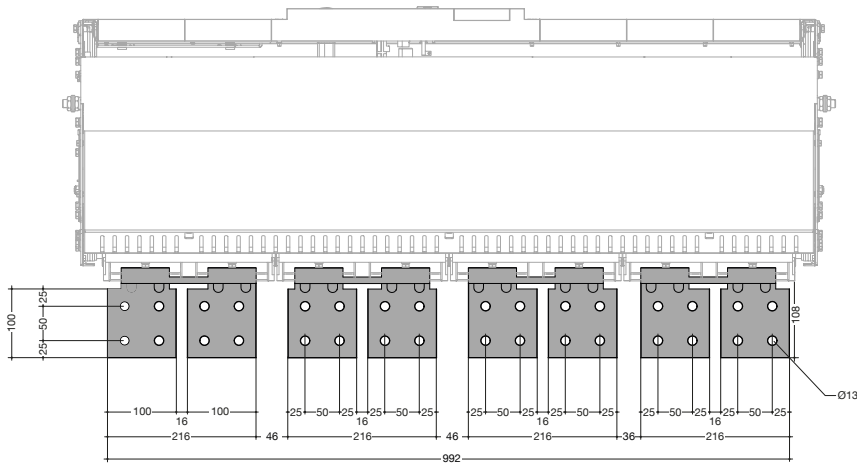

The dimensions given are only valid for the 4-pole fixed and drawout versions.

**HW6 rear vertical RC connections**

For 3 or 4-pole drawout versions from 3200A to 6300A.

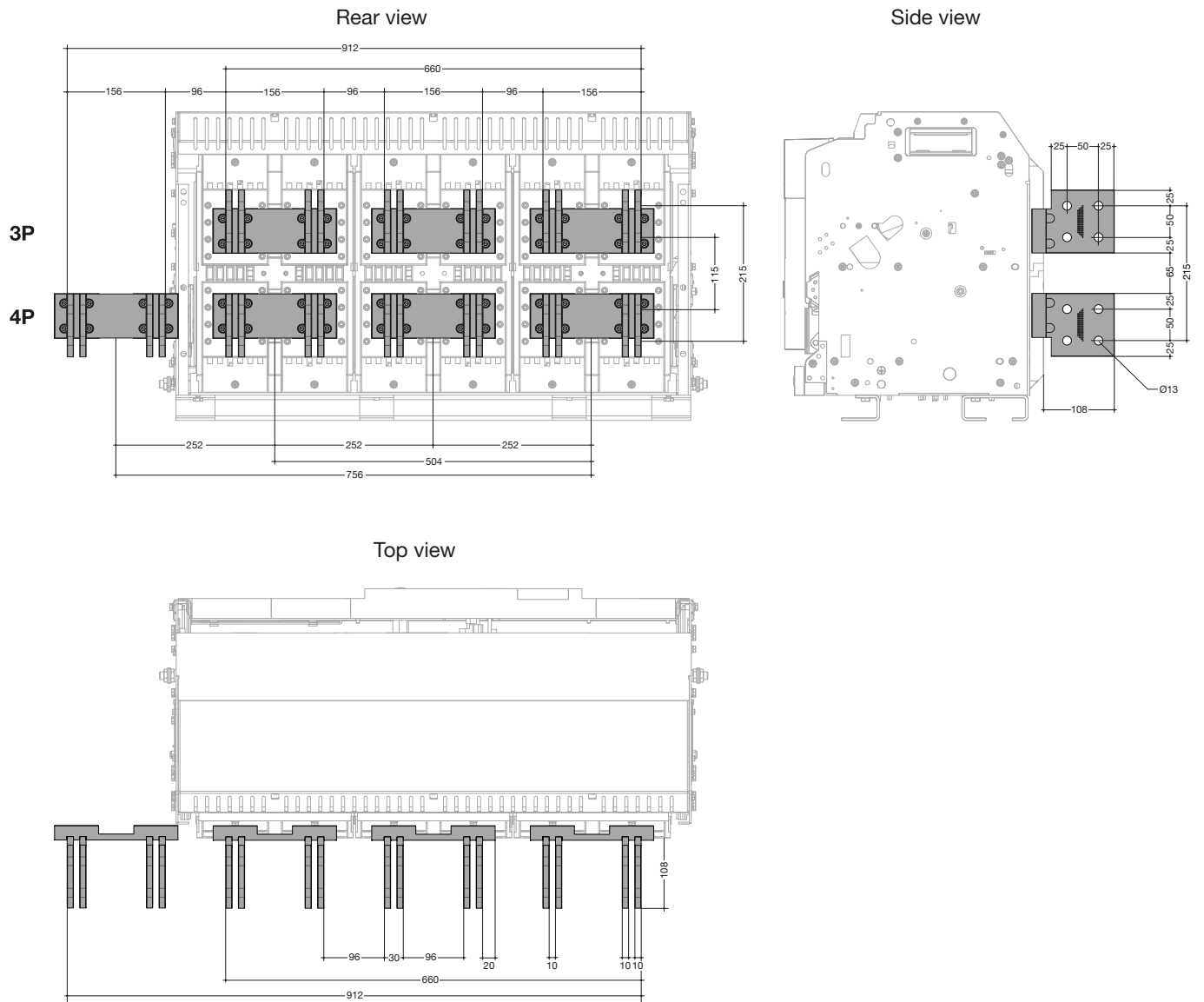

The dimensions given are valid for the drawout versions.





# Complementary characteristics

Page

---

01 Tripping curves

180

---

02 Thermal constraint and limitation curves

188

---

**Tripping tolerance of electronic trip units**

The tolerances of the protection tripping curves for electronic trip units are described below.

**Tolerances of LI, LSI and LSIg tripping curves**

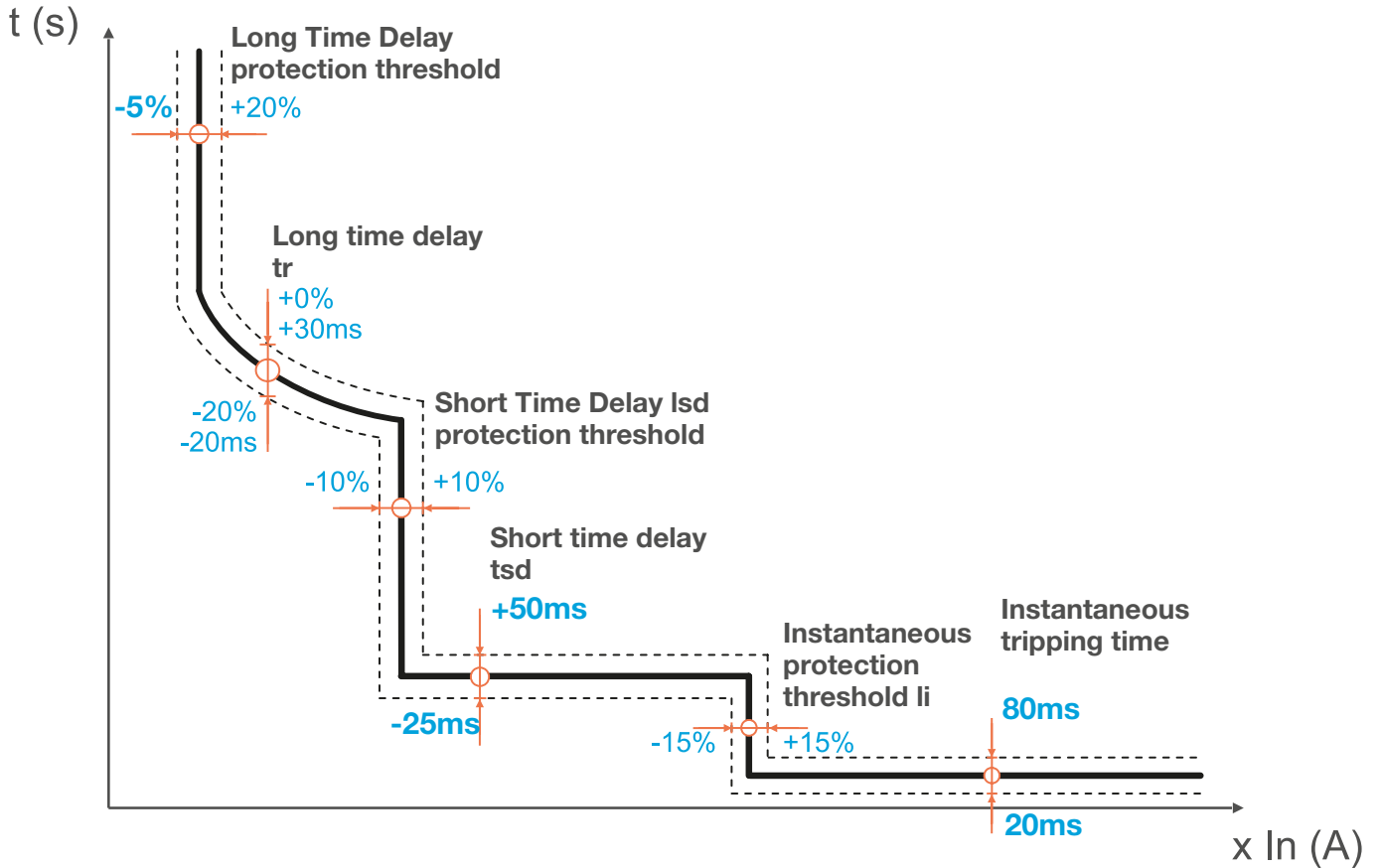

**Tolerances of the earth fault protection curve (GF) for the LSIg trip unit**

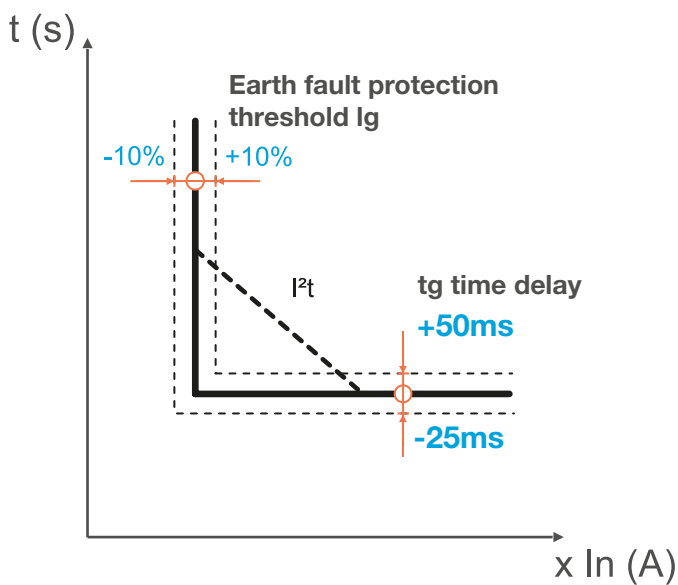

Air circuit breaker with LI sentinel electronic trip unit

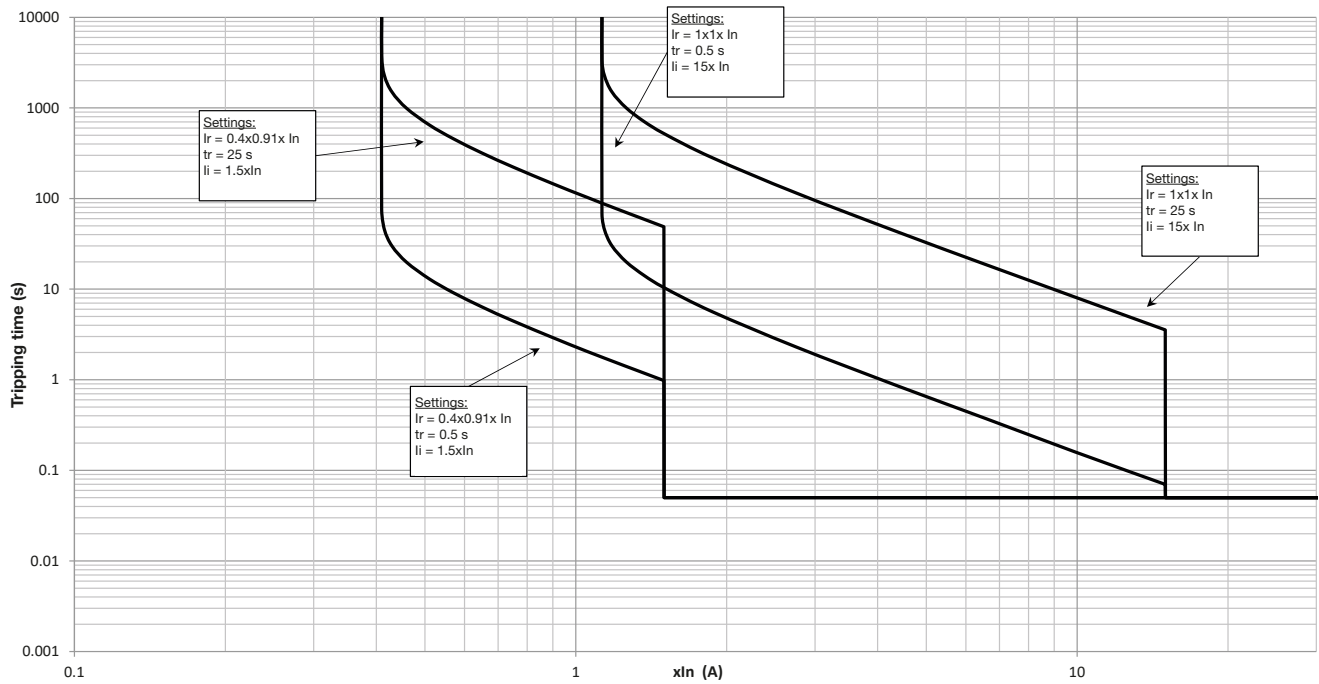

Air circuit breaker with LSI sentinel electronic trip unit

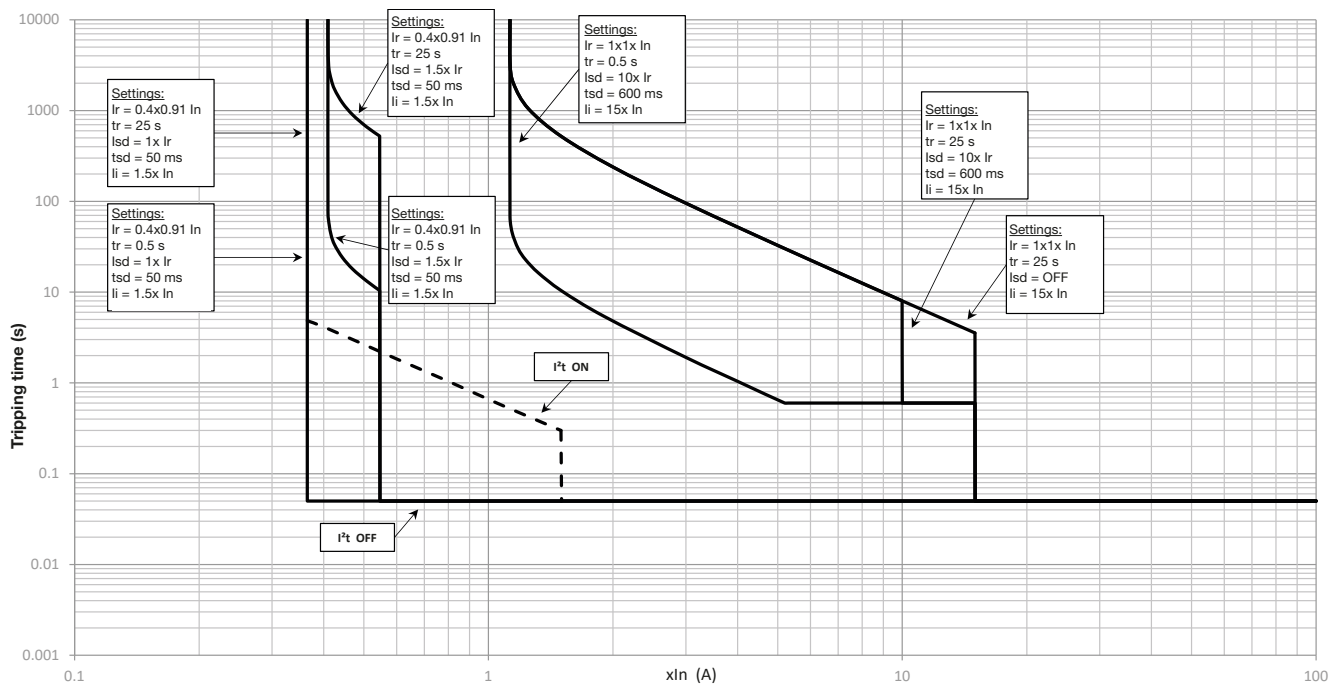

Air circuit breaker with LSIG sentinel electronic trip unit

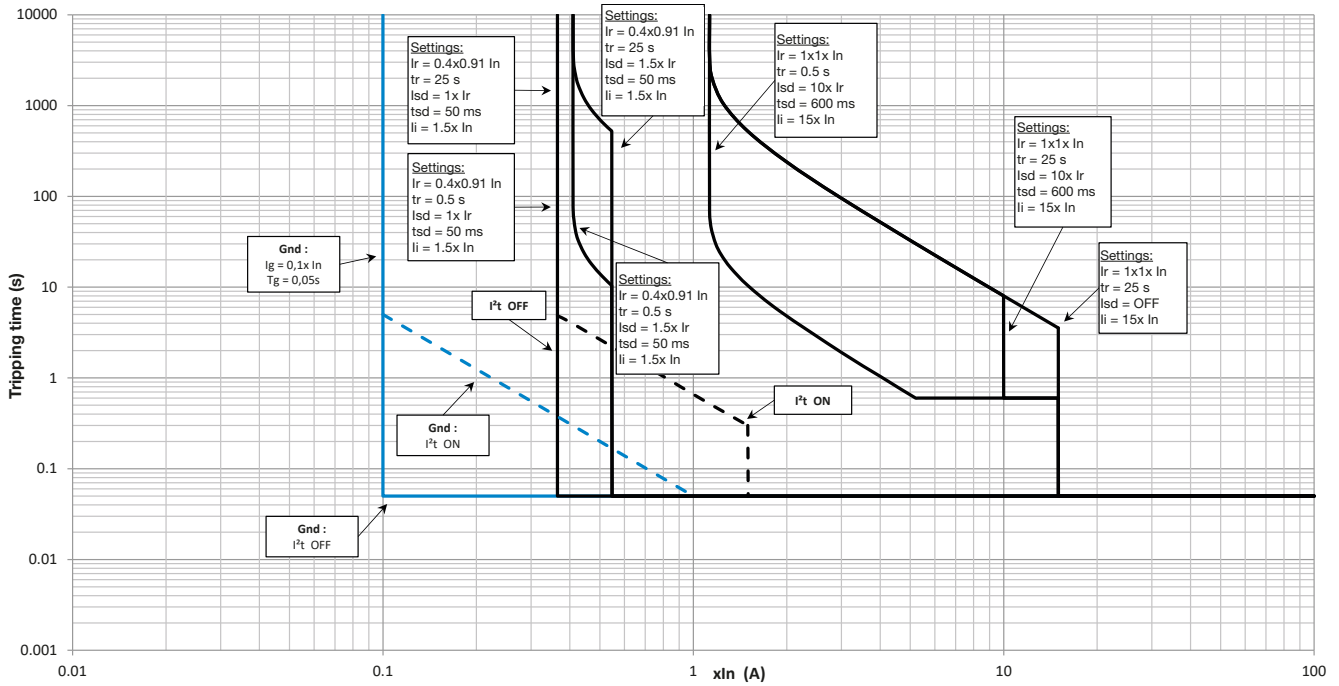

Earth fault curve

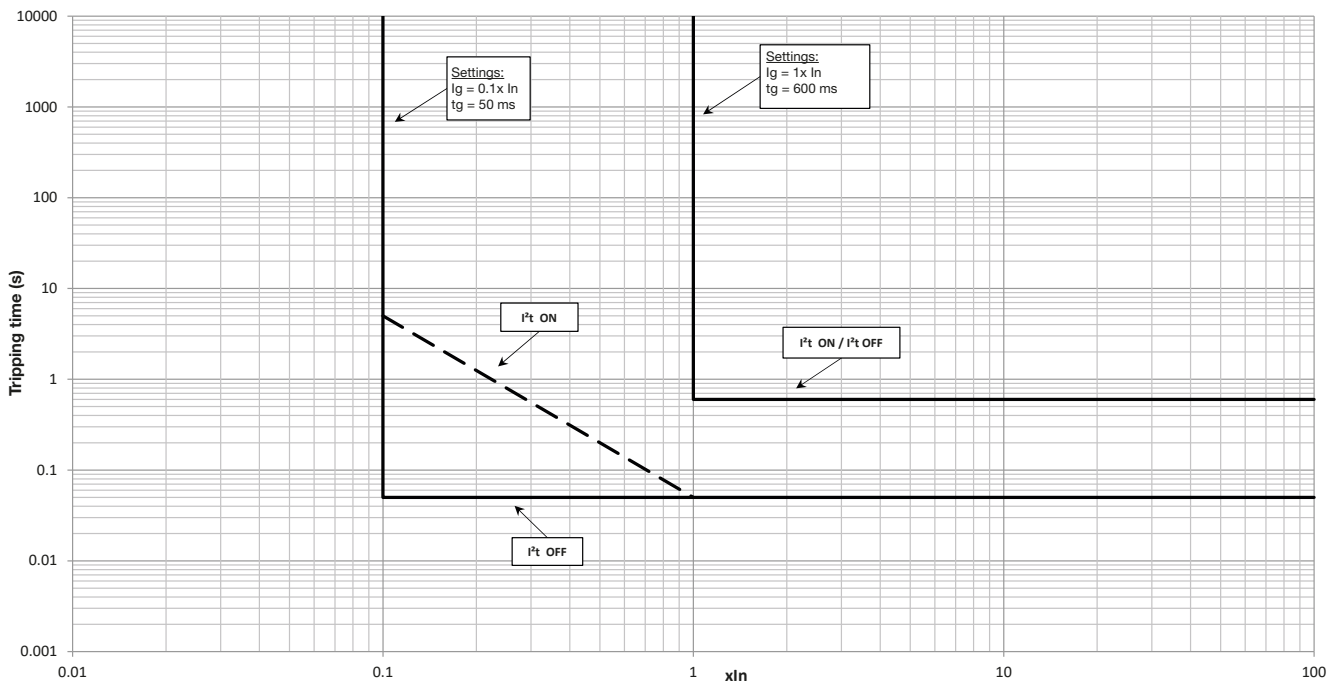

Air circuit breaker with LSI sentinel Energy electronic trip unit – Thi curve

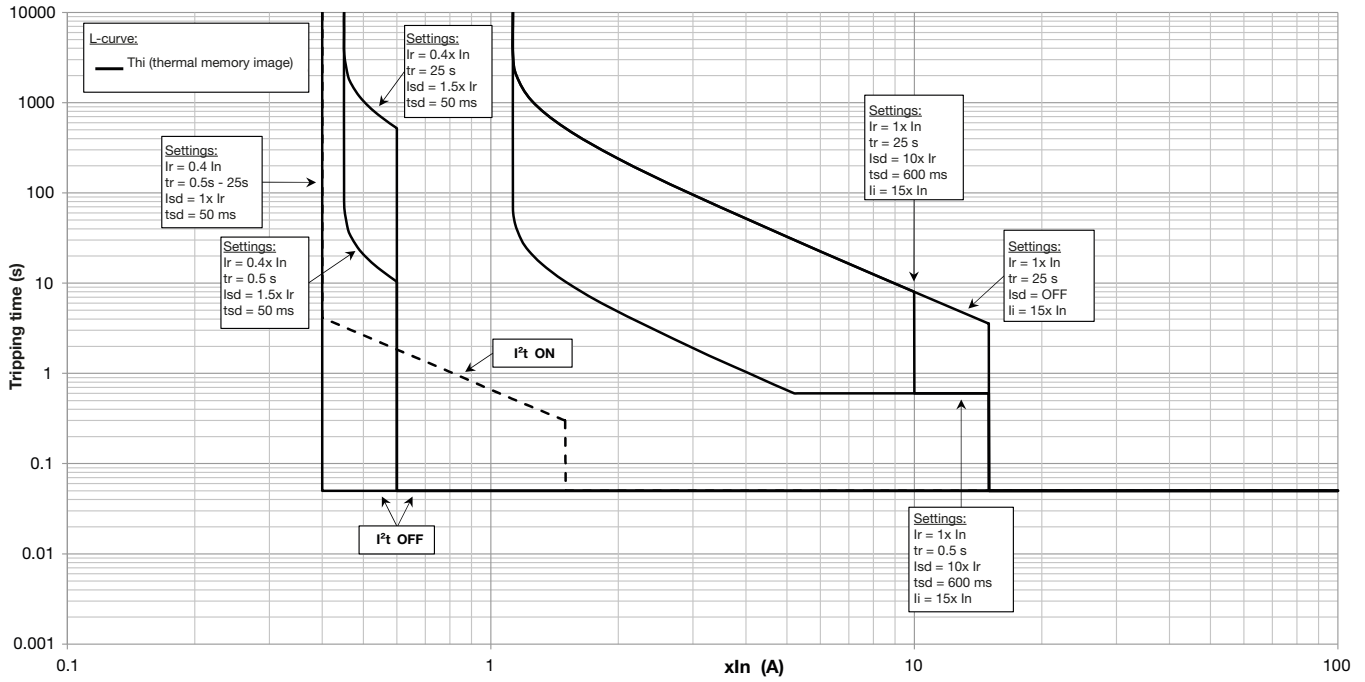

Air circuit breaker with LSI sentinel Energy electronic trip unit – SI I0.02t

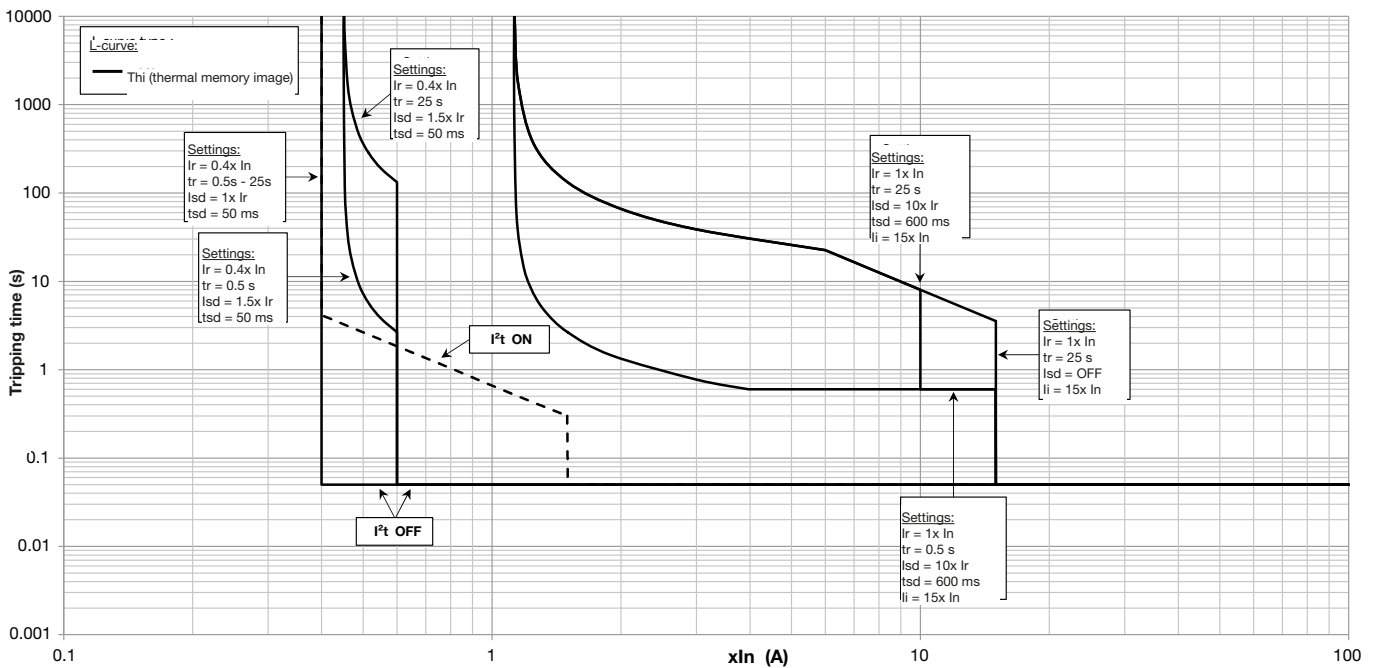

### Air circuit breaker with LSI sentinel Energy electronic trip unit – VI It

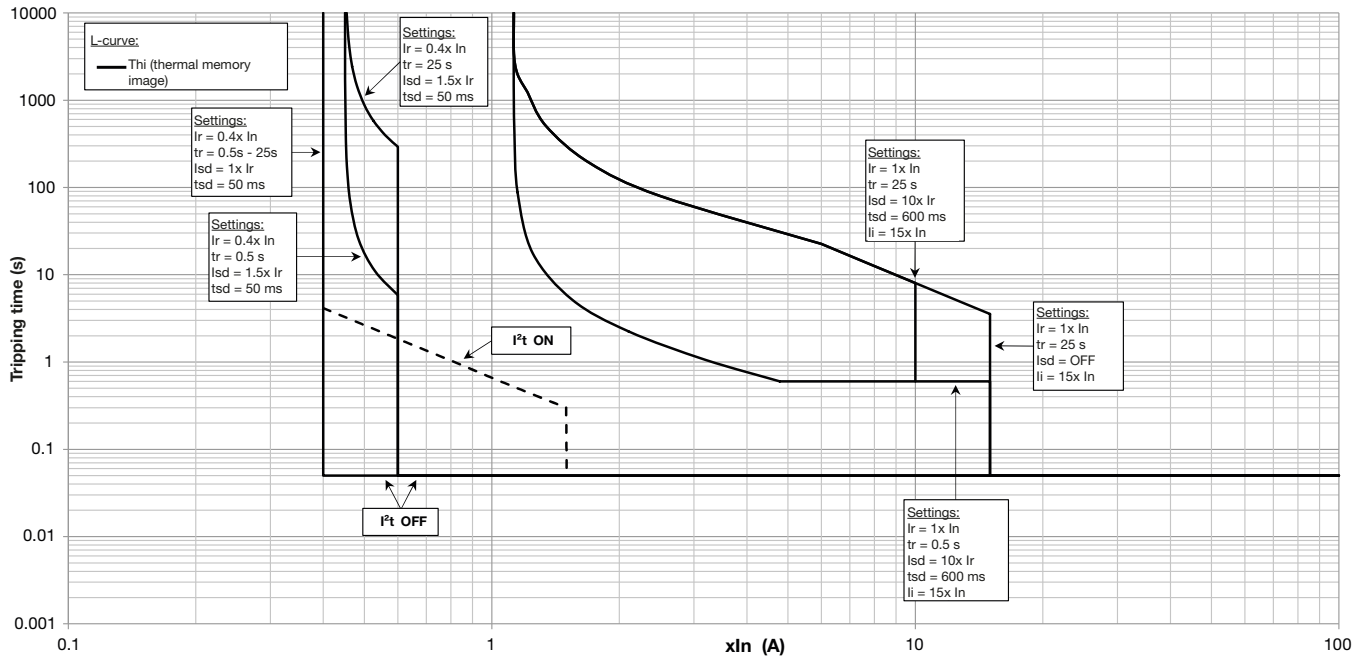

### Air circuit breaker with LSI sentinel Energy electronic trip unit – EI I2t

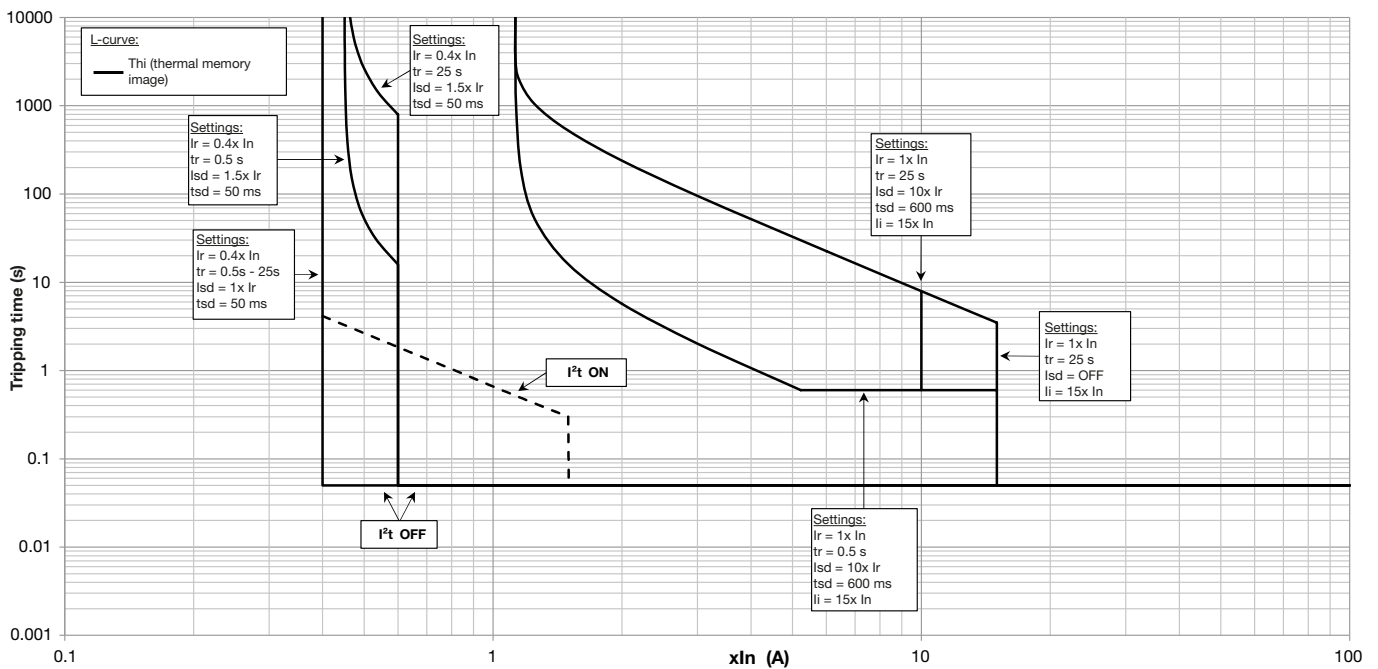

Air circuit breaker with LSI sentinel Energy electronic trip unit – HVF I4t

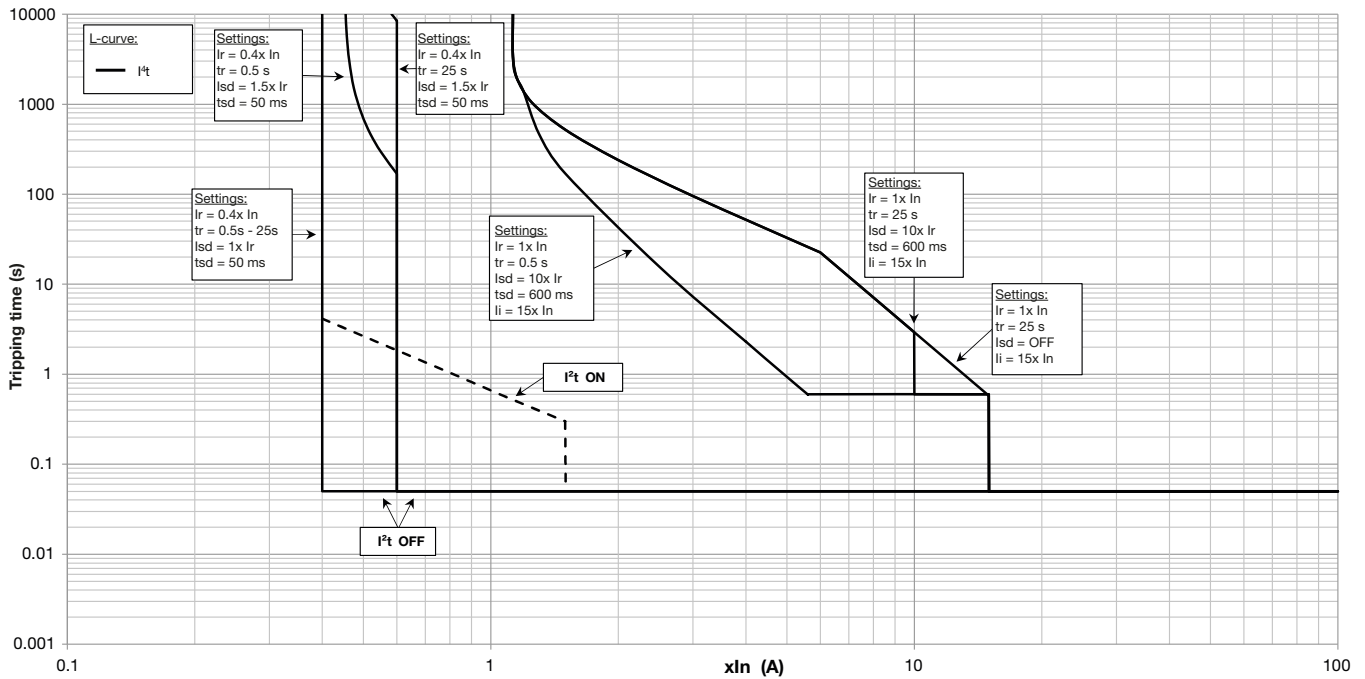

Air circuit breaker with LSiG sentinel Energy electronic trip unit – Thi curve

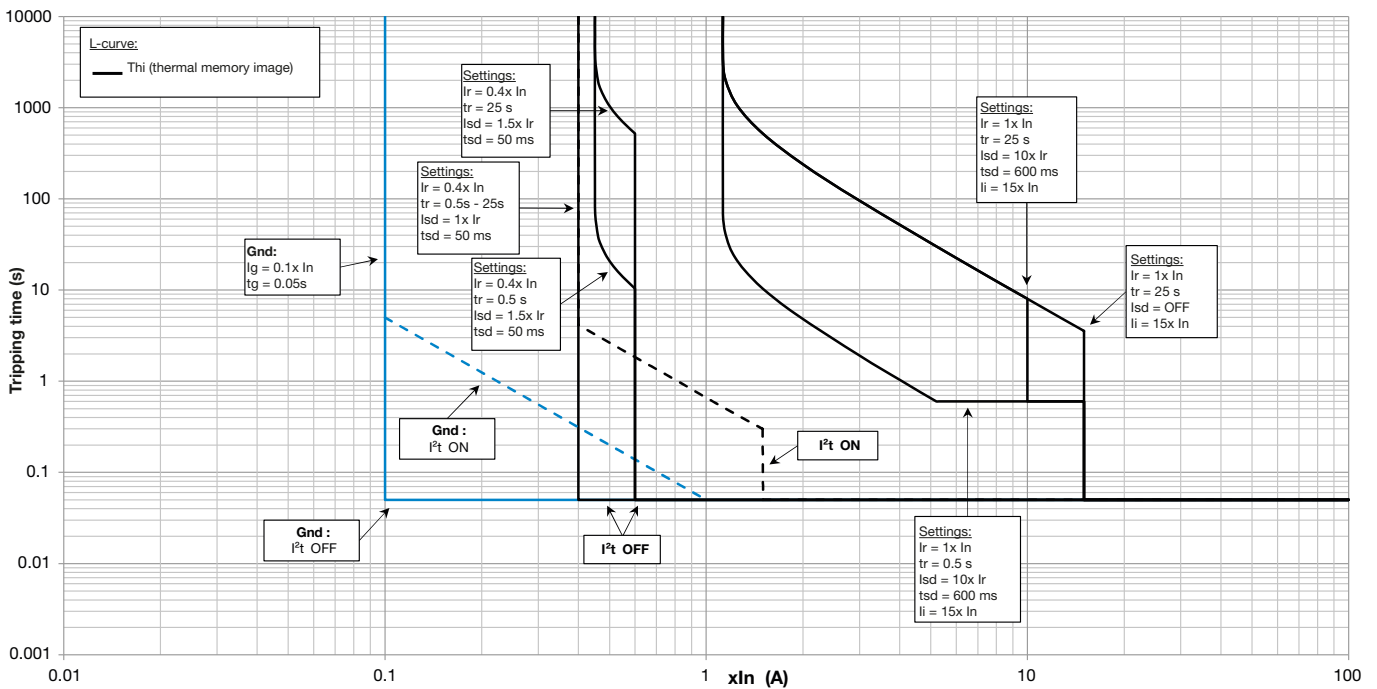

### Air circuit breaker with LSIG sentinel Energy electronic trip unit – SI I0.02t

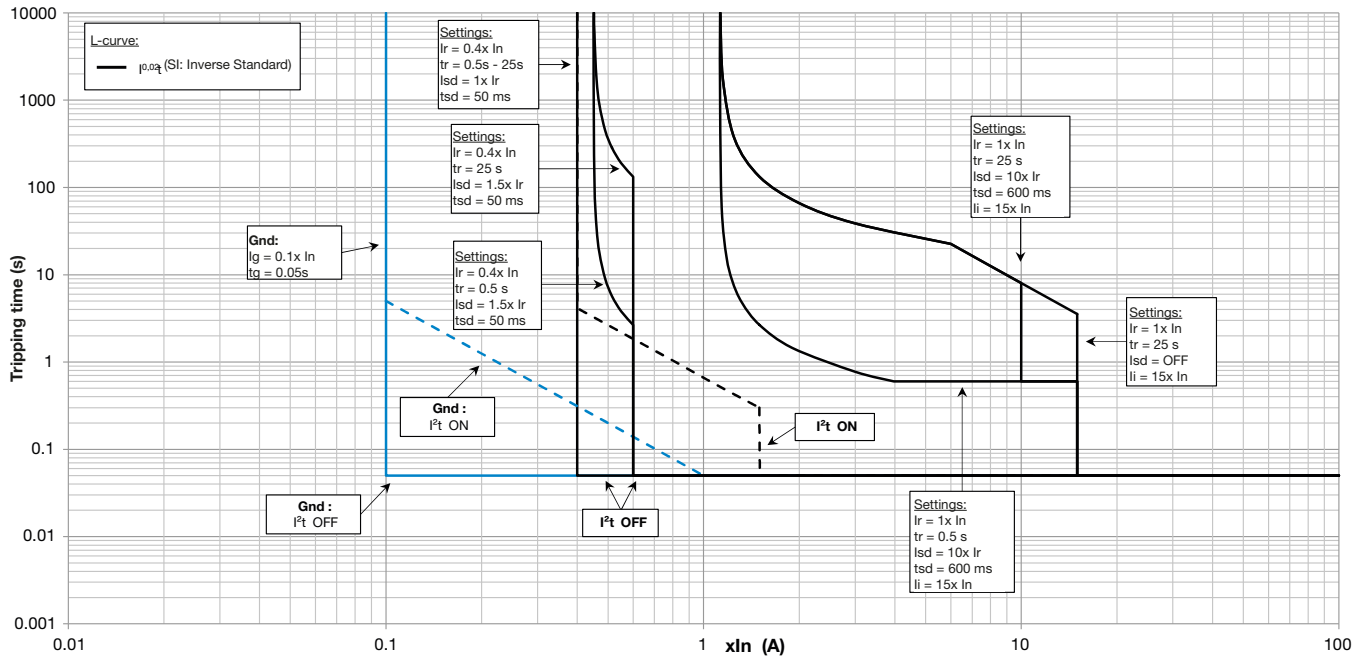

### Air circuit breaker with LSIG sentinel Energy electronic trip unit – VI It

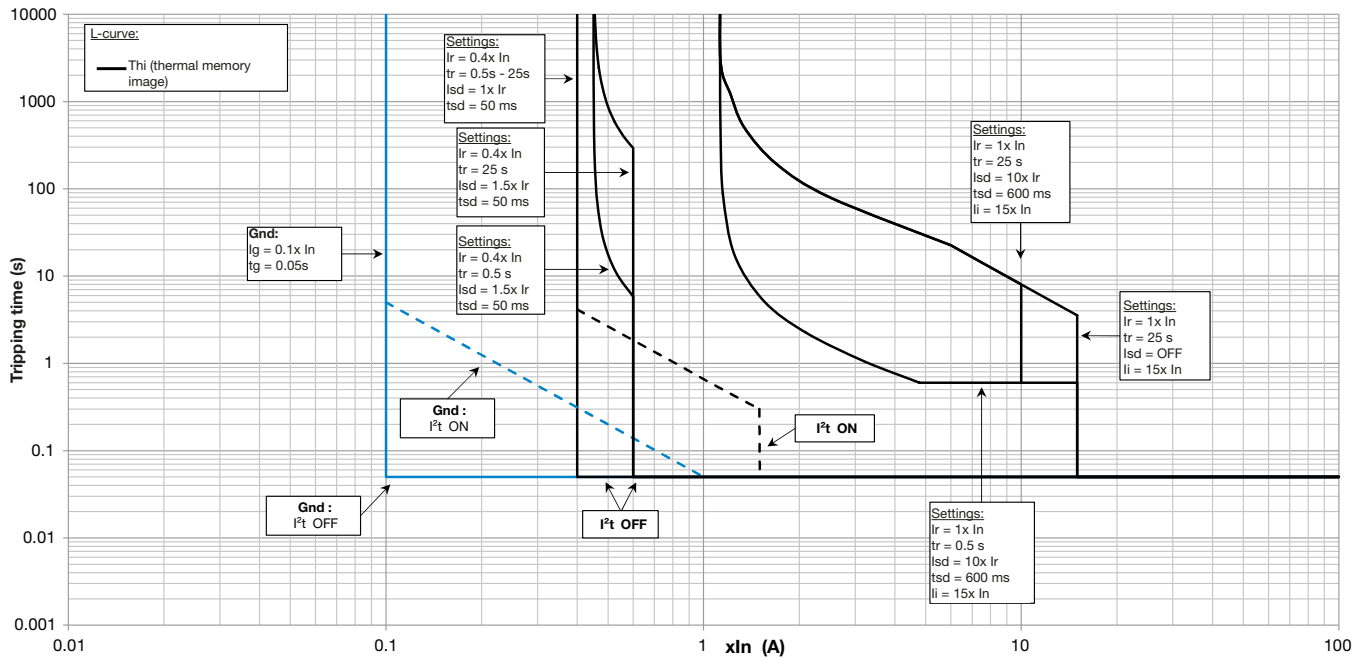



**Air circuit breaker with LSIG sentinel Energy electronic trip unit – EI I2t**

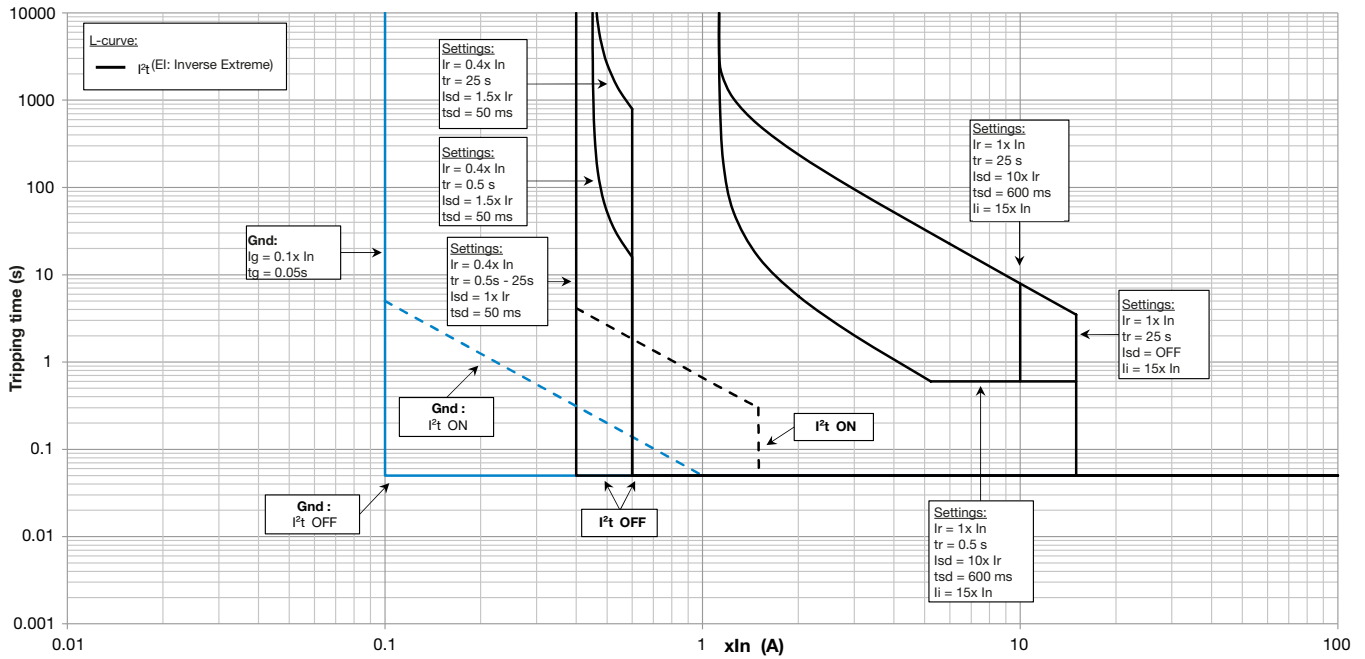

**Air circuit breaker with LSIG sentinel Energy electronic trip unit – HVF I4t**

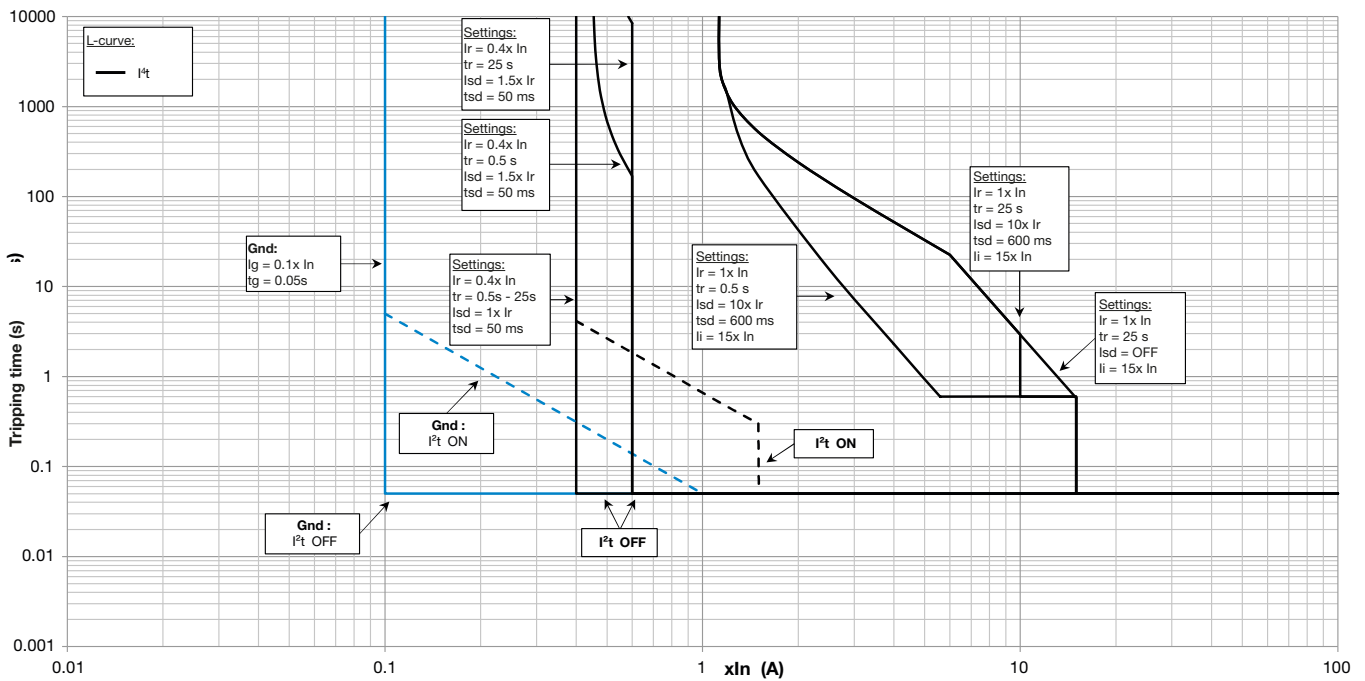

Let-through energy curve (thermal constraint) 380/440 V AC for HW1

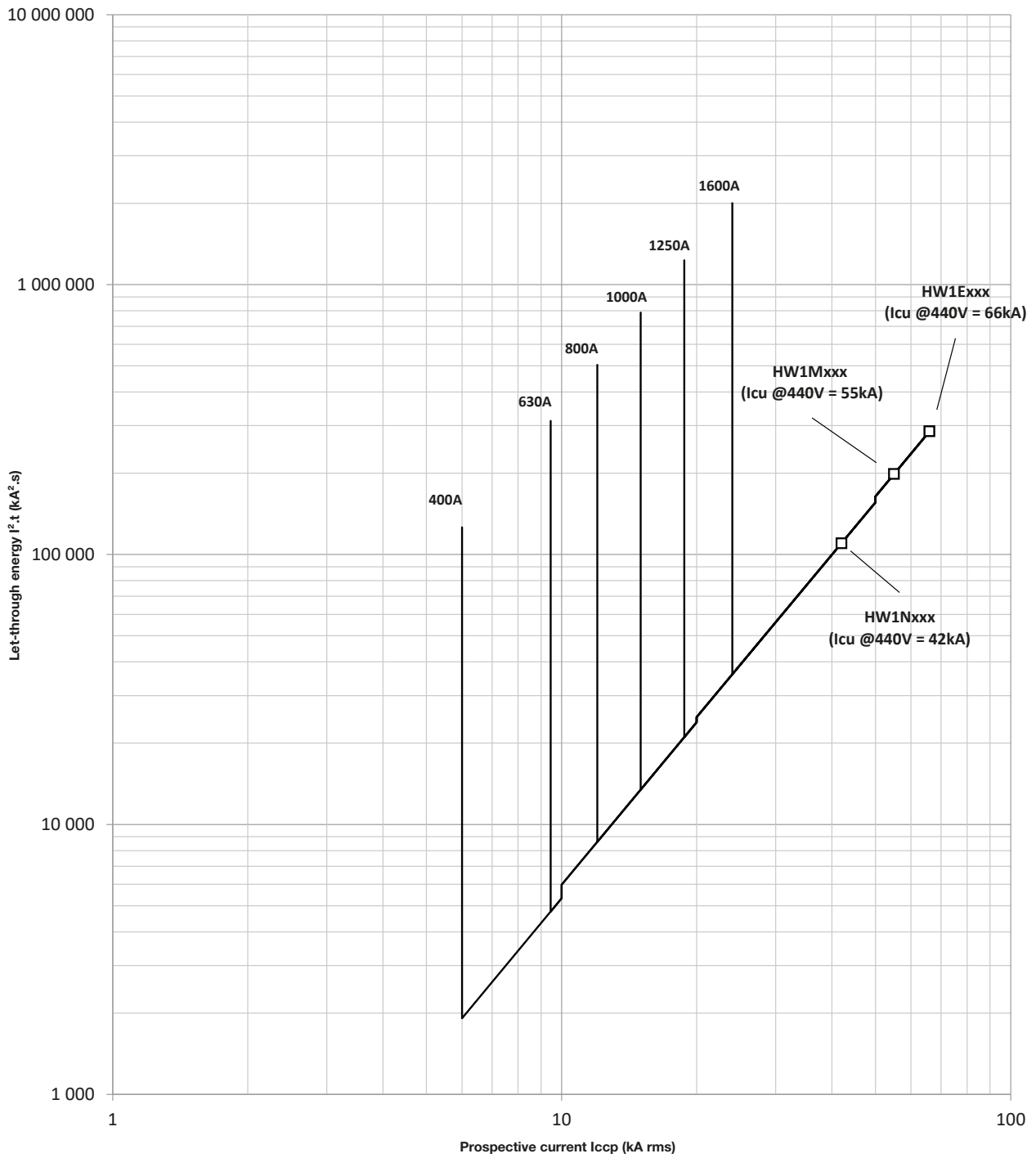

**Let-through energy curve (thermal constraint) from 440 V AC up to 690 V AC for HW1**

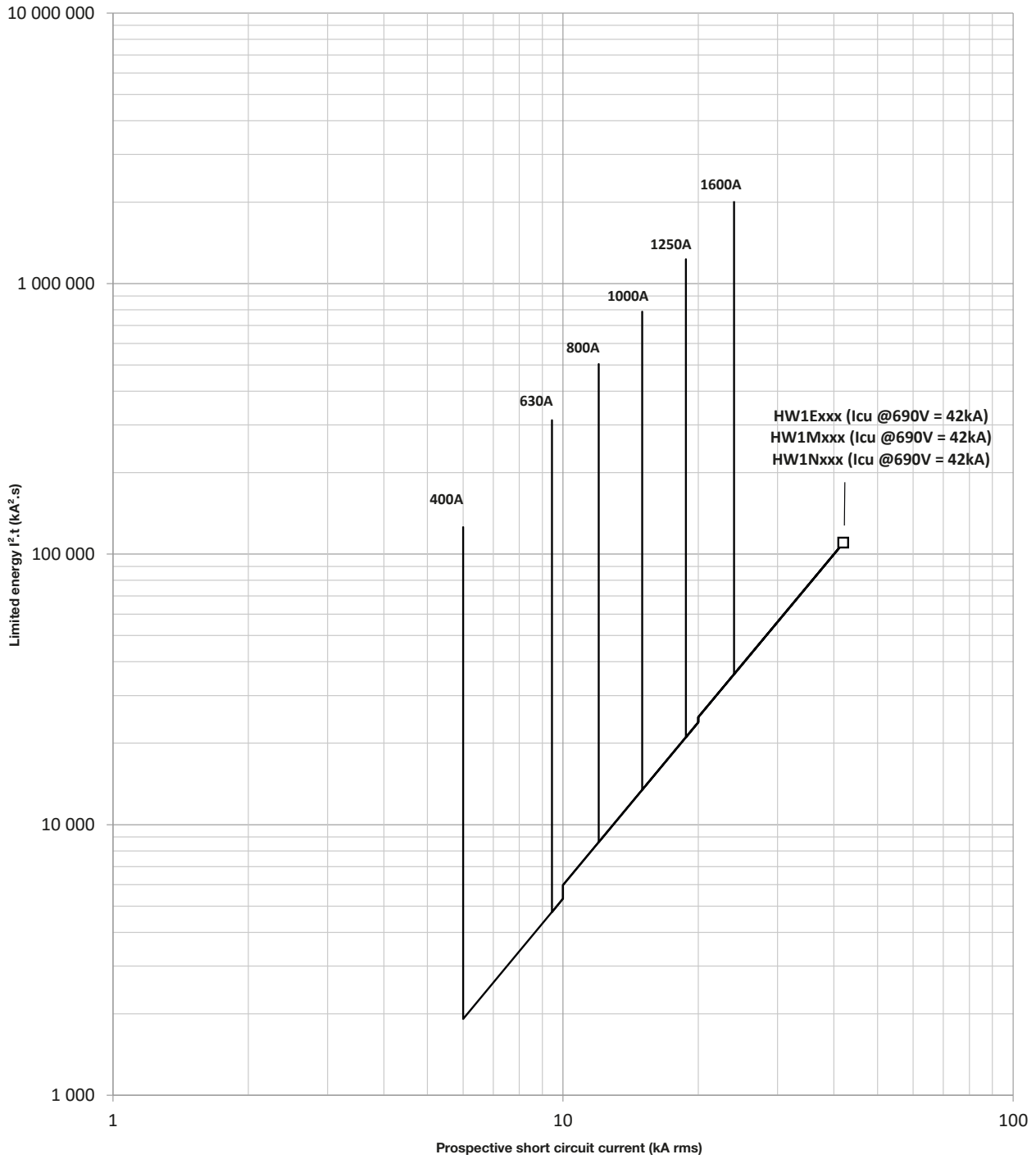

Let-through energy curve (thermal constraint) 380/440 V AC for HW2

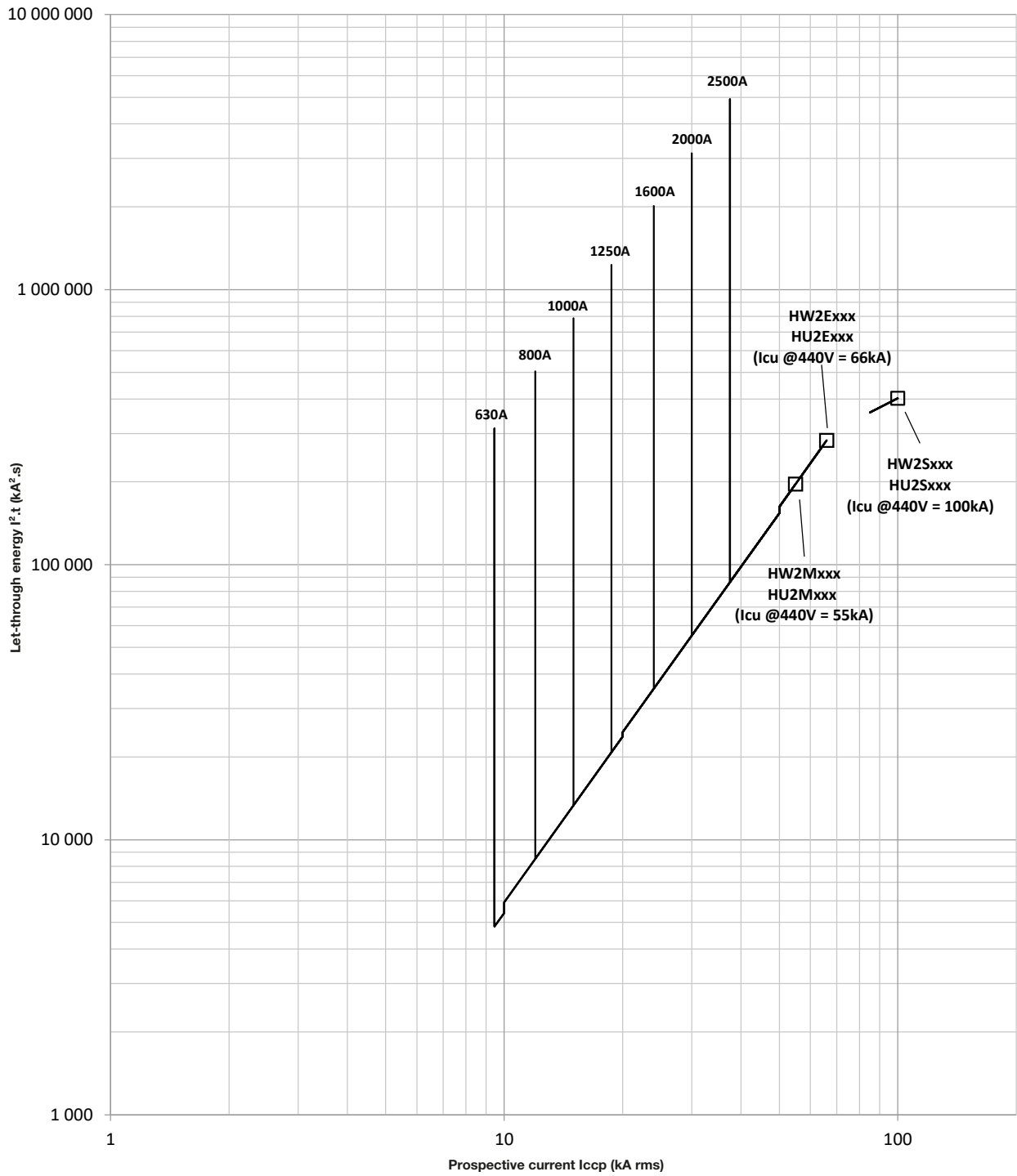

Let-through energy curve (thermal constraint) from 440 V AC up to 690 V AC for HW2

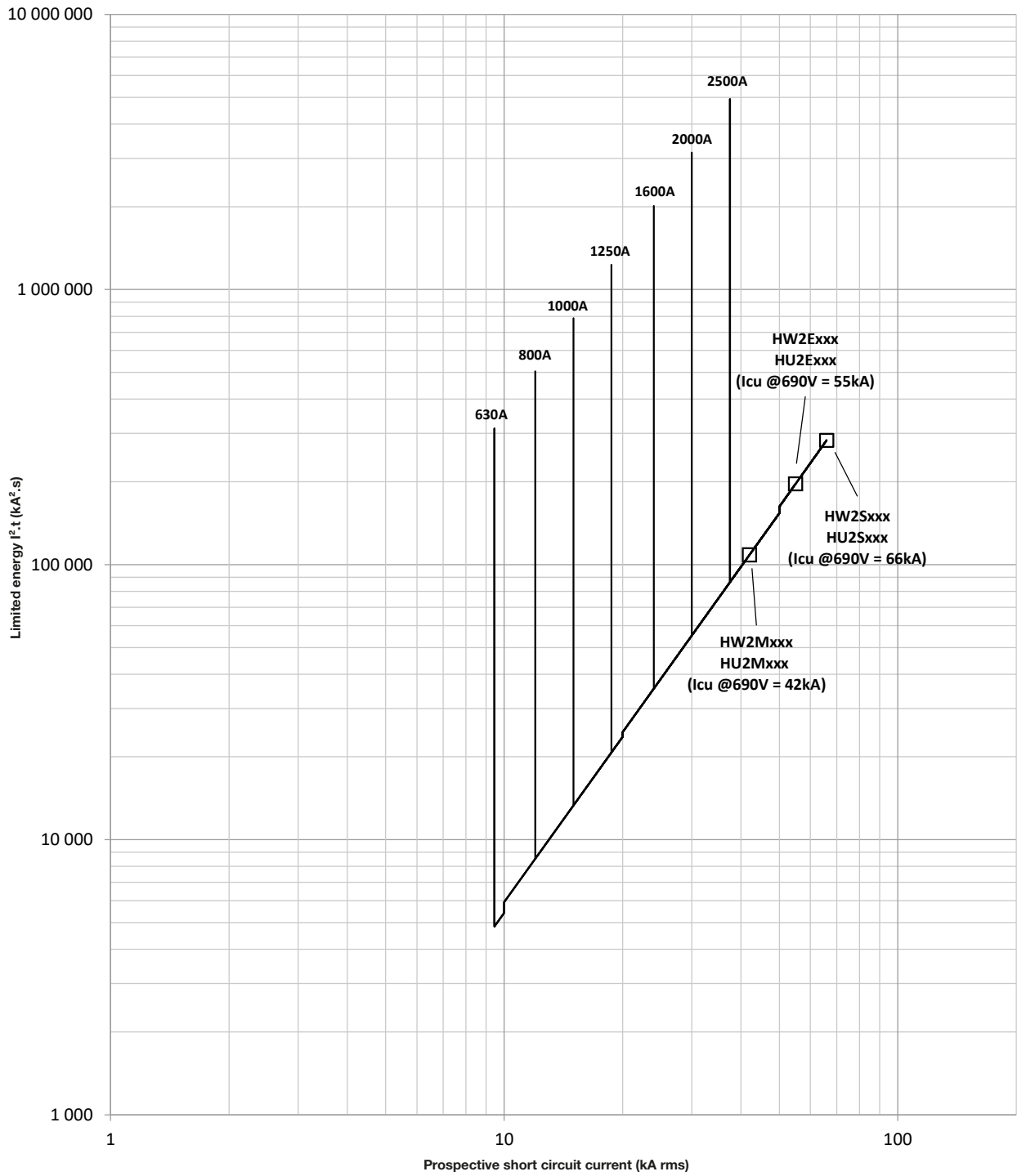

Let-through energy curve (thermal constraint) 380/440 V AC for HW4

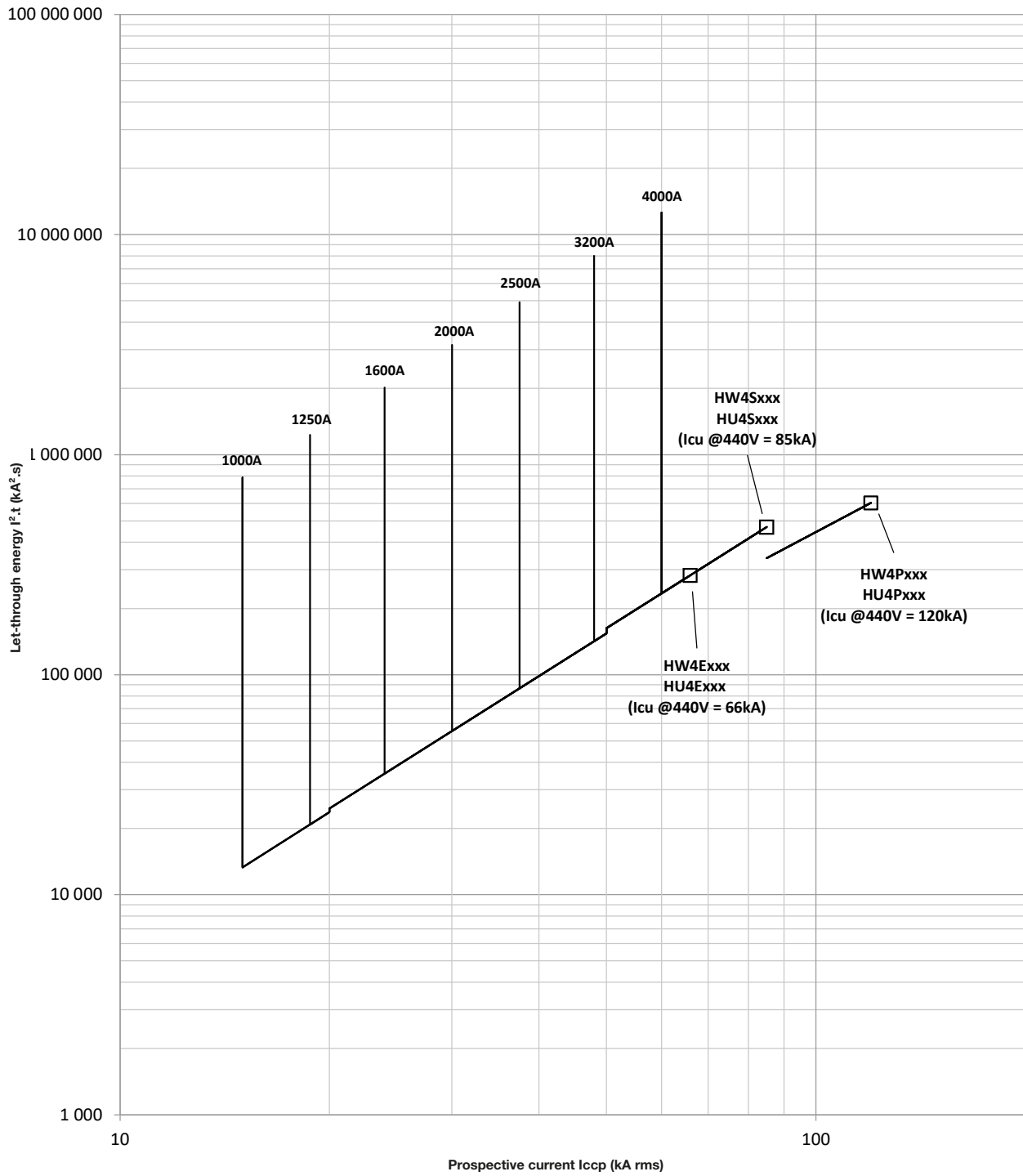

Let-through energy curve (thermal constraint) from 440 V AC up to 690 V AC for HW4

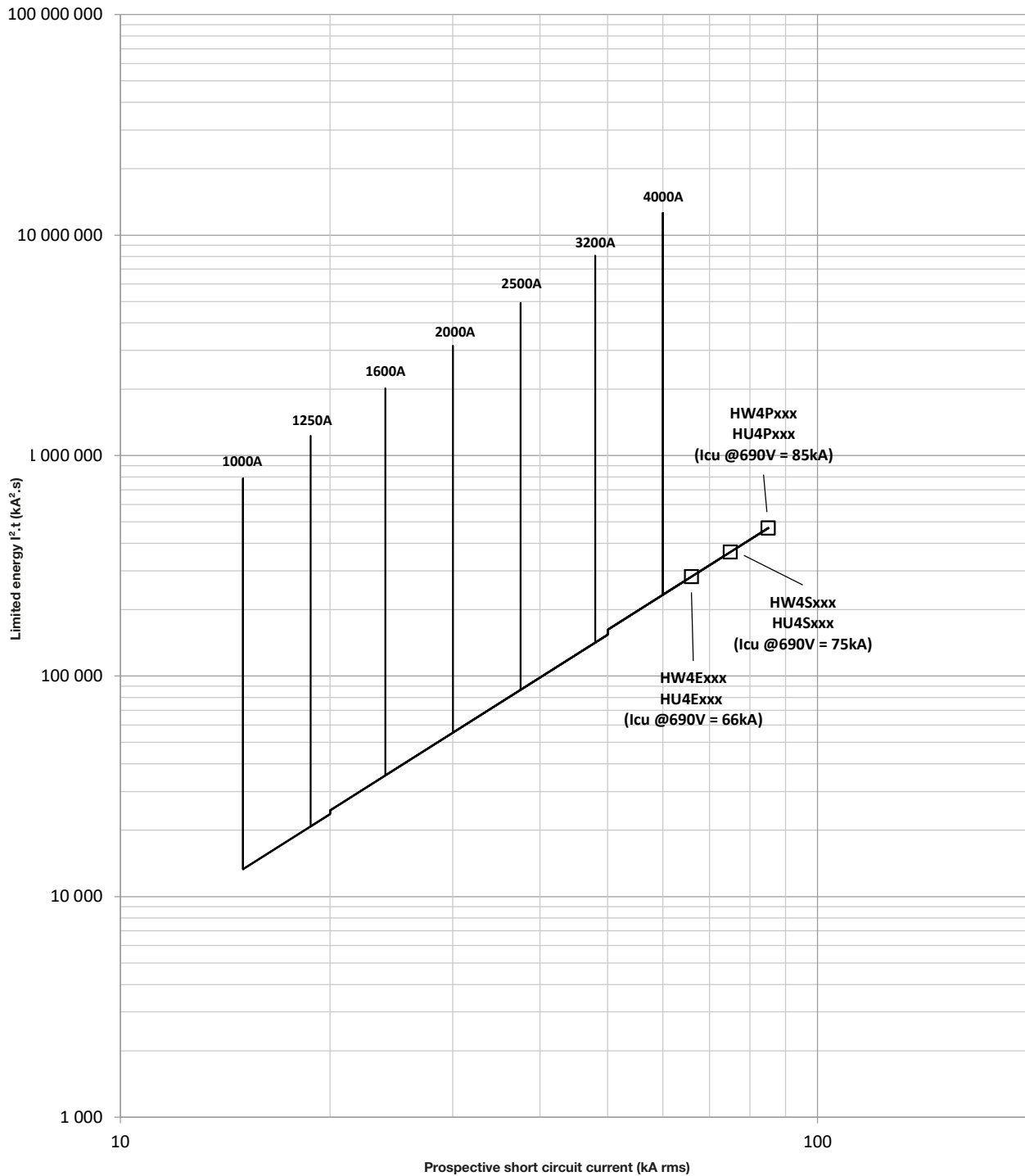

Current limiting characteristics 80/440 V AC for HW1

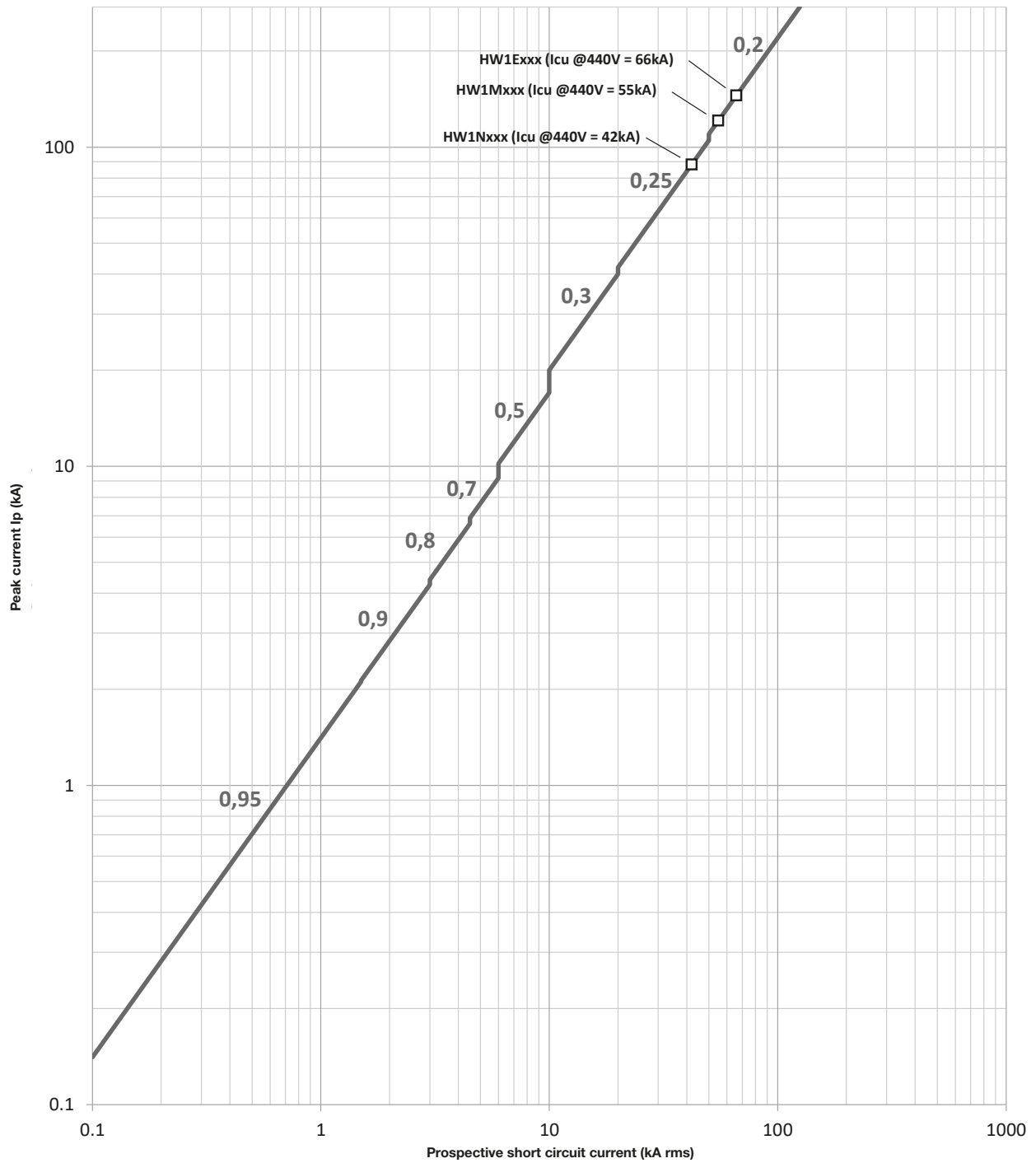



**Current limiting characteristics from 440 V AC to 690 V AC for HW1**

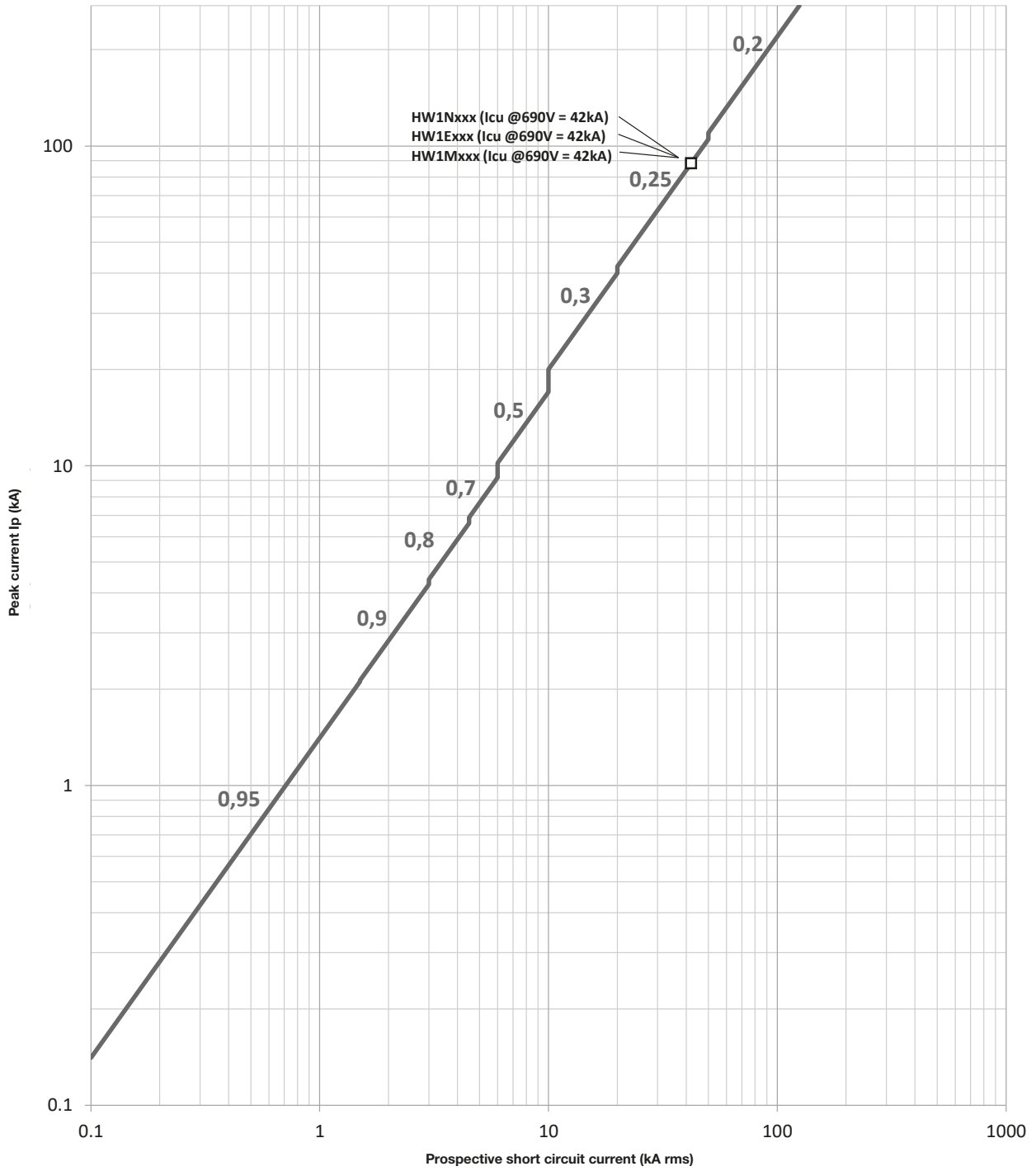

Current limiting characteristics 380/440 V AC for HW2

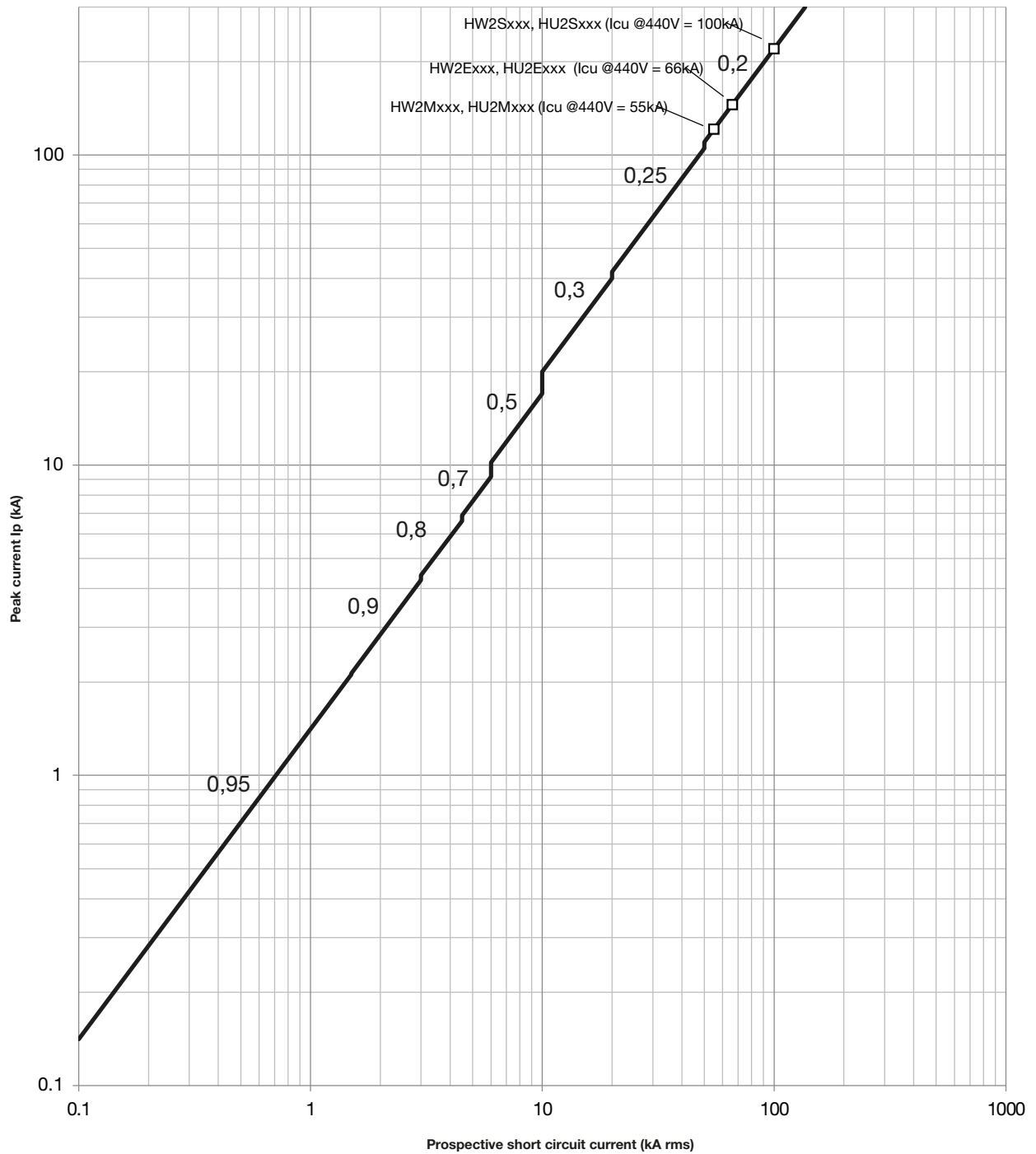

**Current limiting characteristics from 440 V AC to 690 V AC for HW2**

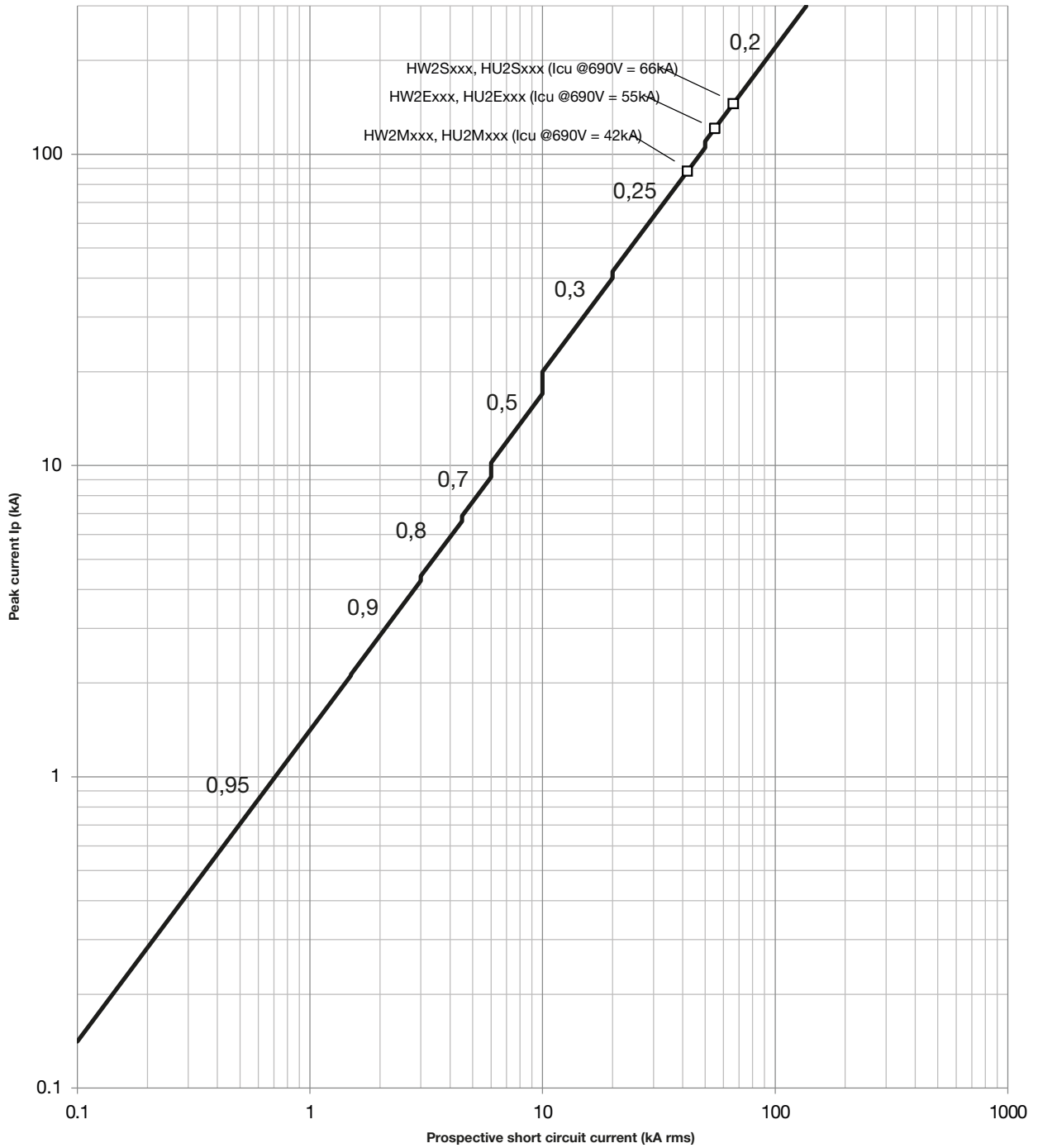

Current limiting characteristics 380/440 V AC for HW4

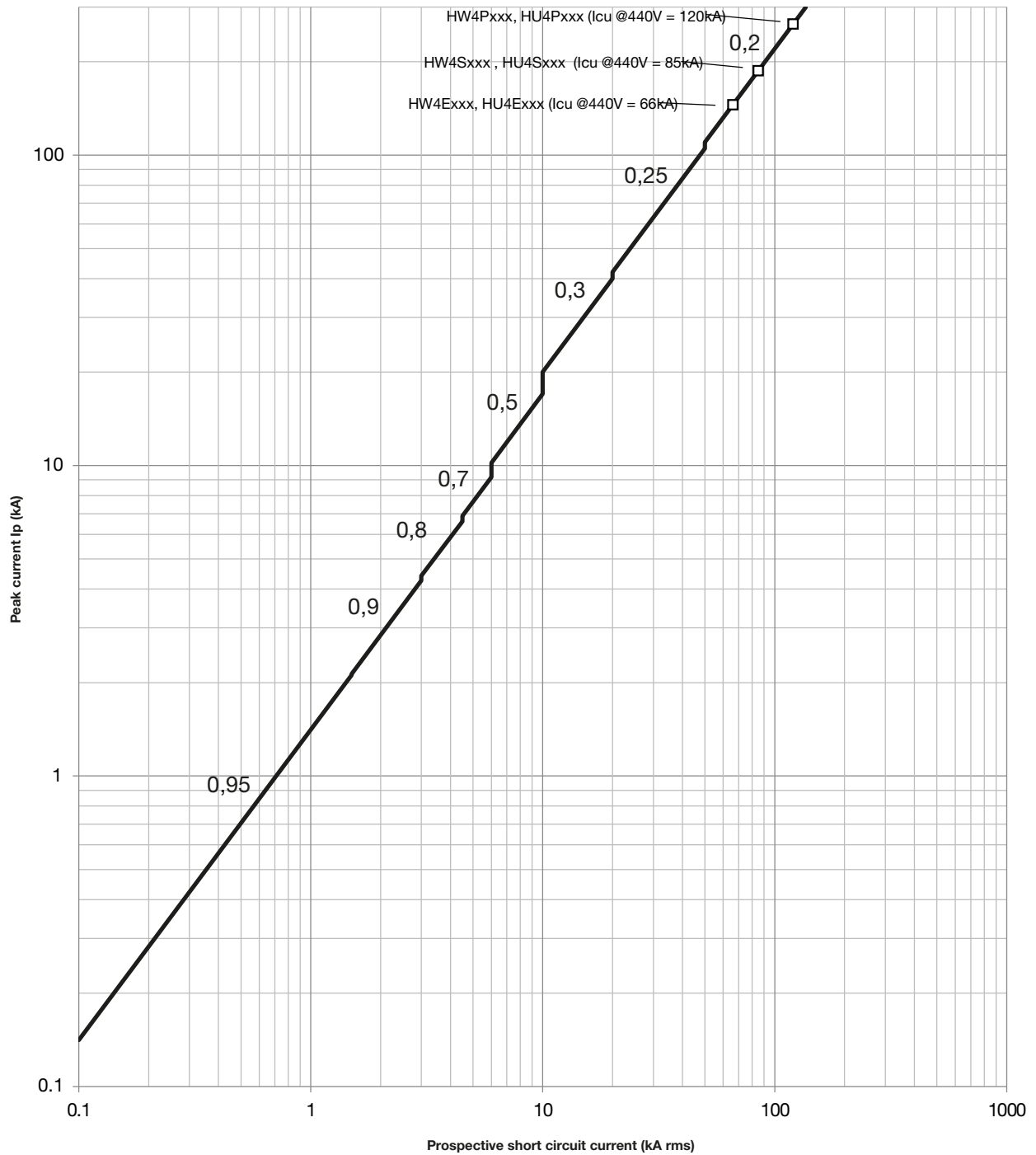

Current limiting characteristics from 440 V AC to 690 V AC for HW4

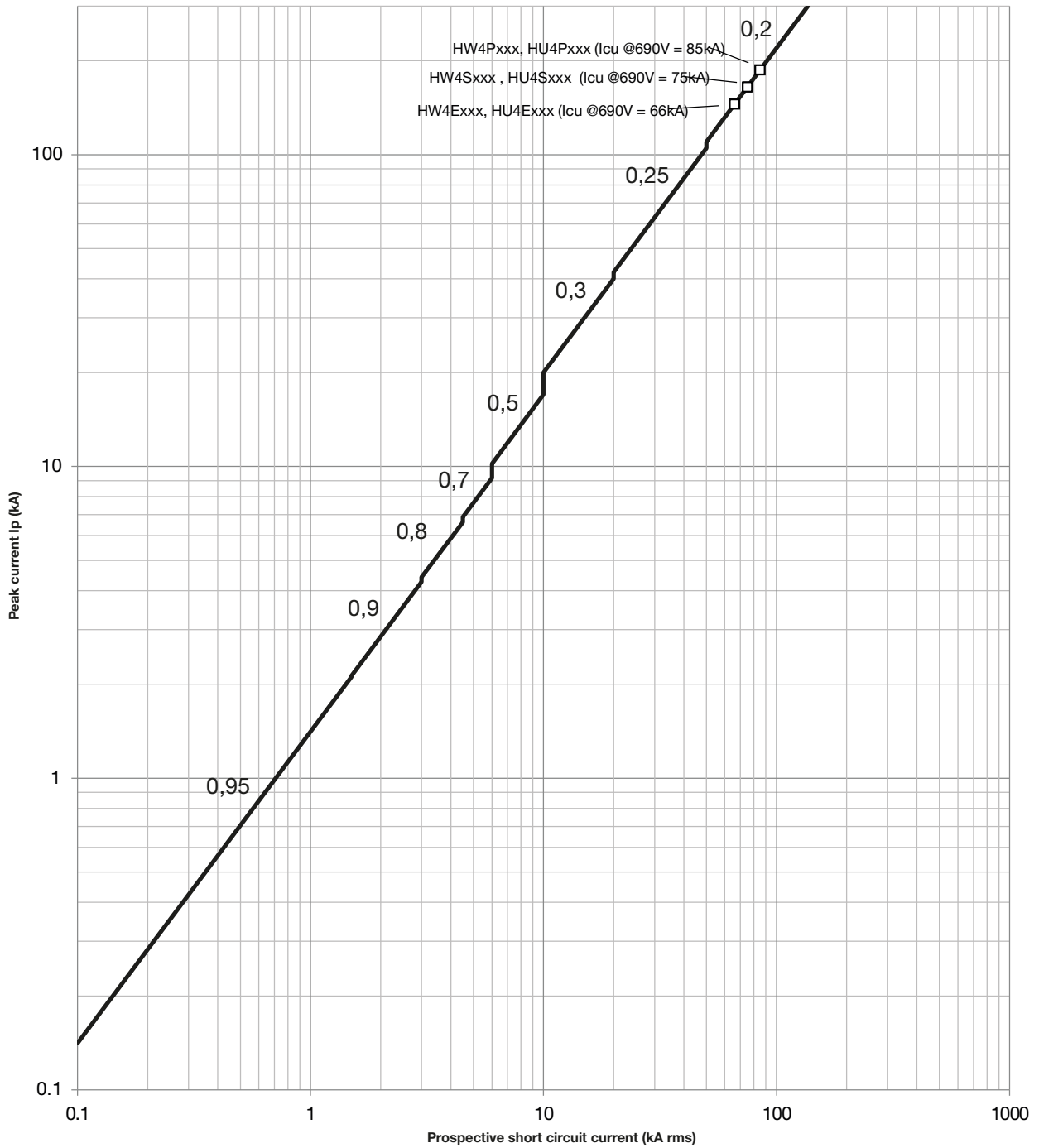

Current limiting characteristics 380/440 V AC for HW6

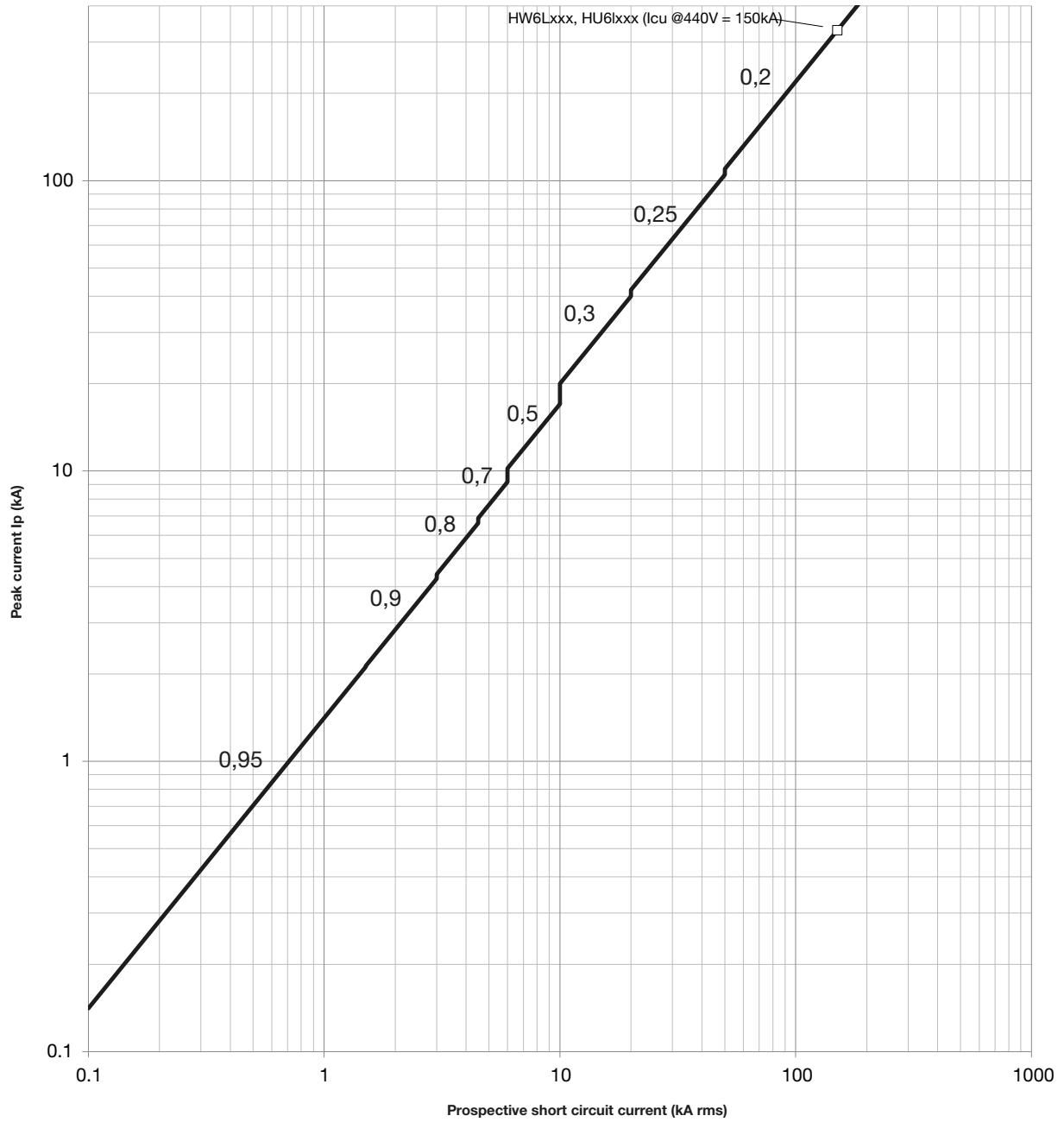

**Current limiting characteristics from 440 V AC to 690 V AC for HW6**

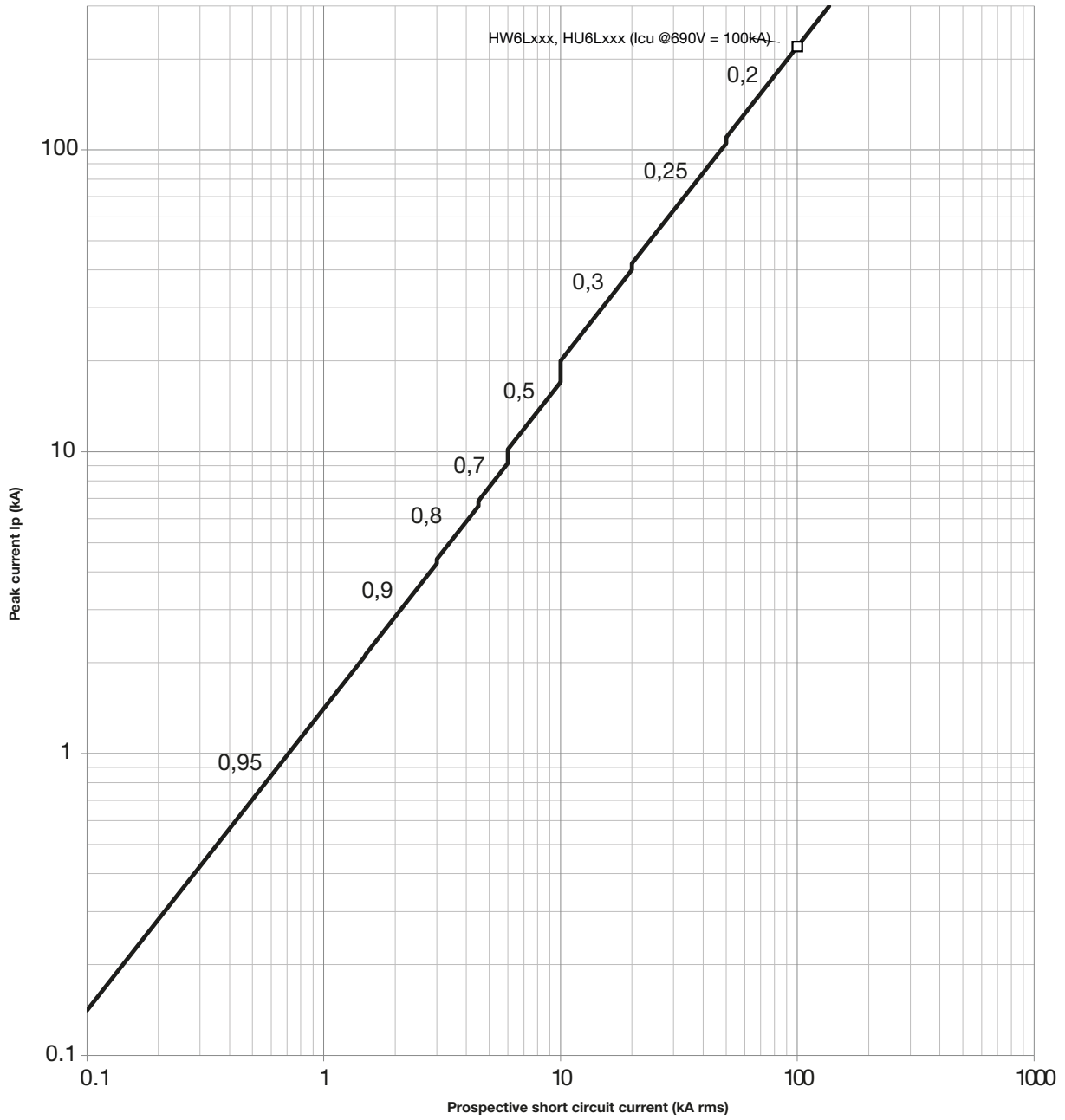

Let-through energy curve (thermal constraint) 380/440 V AC for HW6

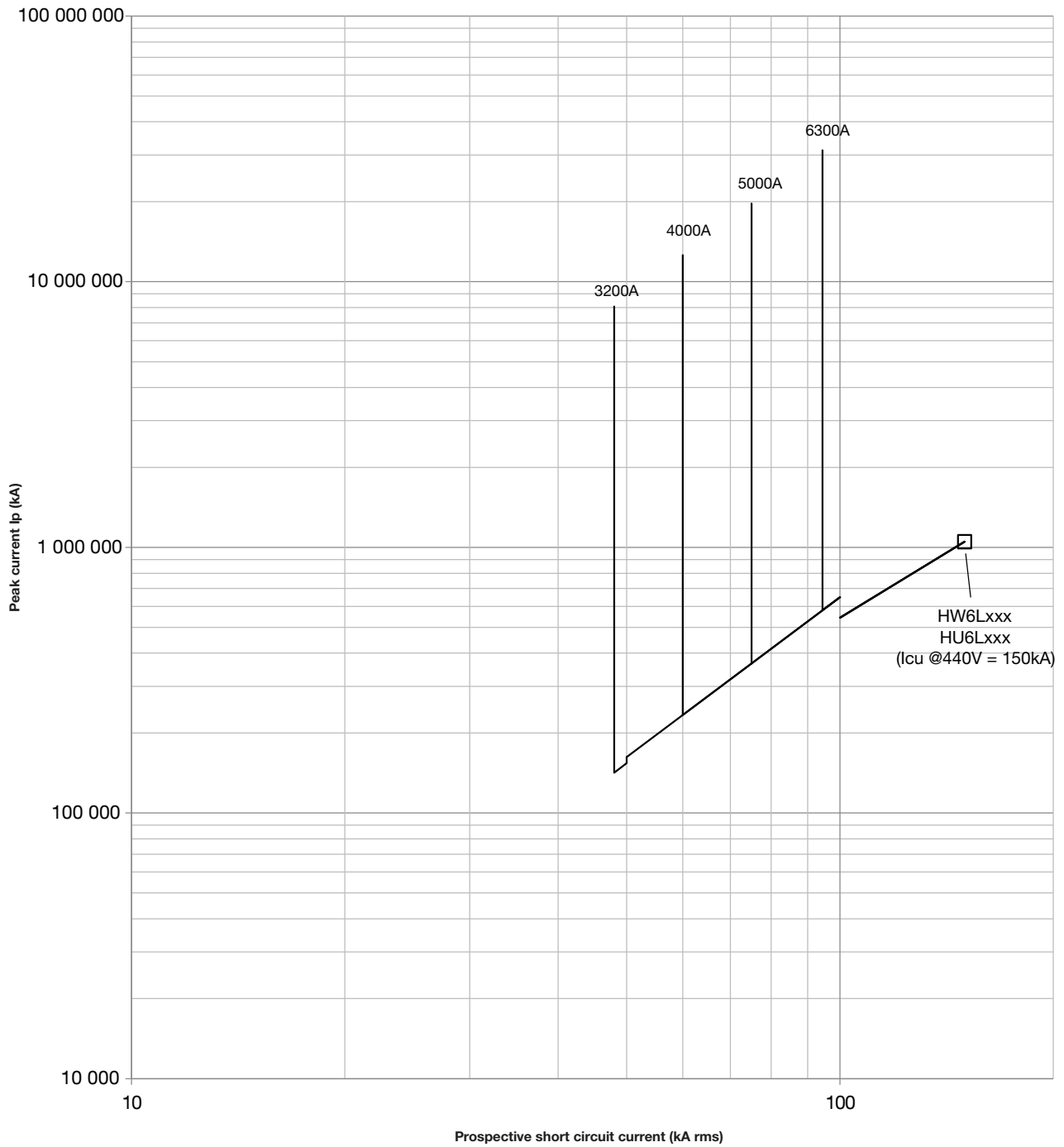



Let-through energy curve (thermal constraint) from 440 V AC up to 690 V AC for HW6

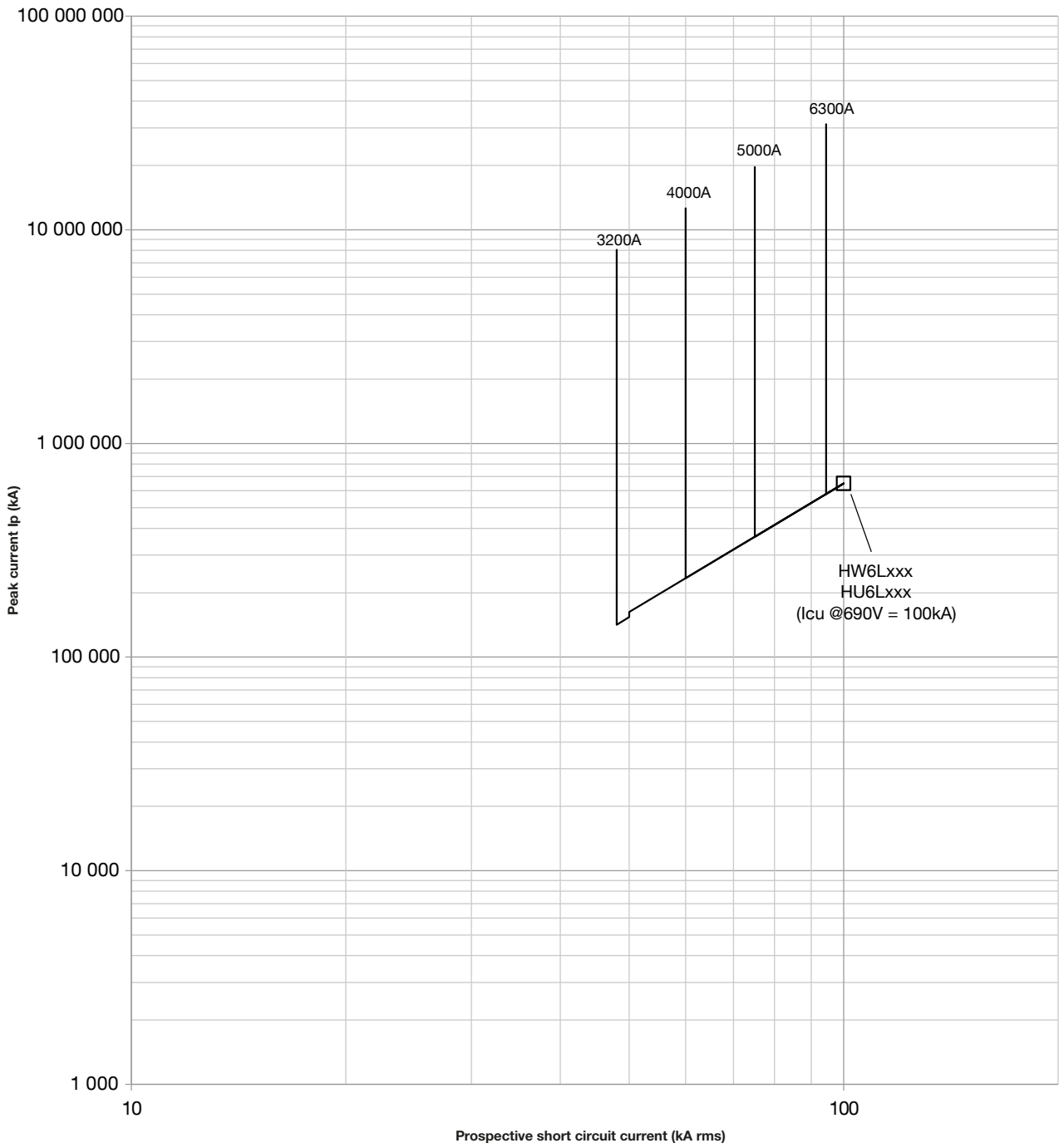







# List of references

	Page
<b>01 Fixed version</b>	<b>206</b>
<b>02 Drawout version</b>	<b>211</b>
<b>03 Electronic trip units</b>	<b>217</b>
<b>04 Control accessories</b>	<b>221</b>
<b>05 Signalling accessories</b>	<b>223</b>
<b>06 Locking and interlocking accessories</b>	<b>225</b>
<b>07 Connection accessories</b>	<b>227</b>
<b>08 Protection accessories</b>	<b>231</b>
<b>09 Connection accessories</b>	<b>233</b>
<b>10 Communication accessories</b>	<b>234</b>



Fixed air circuit breakers for HW1 sentinel electronic trip unit

	Icu 380 – 440 V~	In (A)	3 poles	4 poles
 HW1E316FB	42 kA	400	HW1N304FB	HW1N404FB
		630	HW1N306FB	HW1N406FB
		800	HW1N308FB	HW1N408FB
		1000	HW1N310FB	HW1N410FB
		1250	HW1N312FB	HW1N412FB
		1600	HW1N316FB	HW1N416FB
 HW1E416FB	55 kA	400	HW1M304FB	HW1M404FB
		630	HW1M306FB	HW1M406FB
		800	HW1M308FB	HW1M408FB
		1000	HW1M310FB	HW1M410FB
		1250	HW1M312FB	HW1M412FB
		1600	HW1M316FB	HW1M416FB
HW1E416FB	66 kA	400	HW1E304FB	HW1E404FB
		630	HW1E306FB	HW1E406FB
		800	HW1E308FB	HW1E408FB
		1000	HW1E310FB	HW1E410FB
		1250	HW1E312FB	HW1E412FB
		1600	HW1E316FB	HW1E416FB



Fixed air circuit breakers for HW2 sentinel electronic trip unit

	Icu 380 – 440 V~	In (A)	3 poles	4 poles
 HW2S325FB	55 kA	630	HW2M306FB	HW2M406FB
		800	HW2M308FB	HW2M408FB
		1000	HW2M310FB	HW2M410FB
		1250	HW2M312FB	HW2M412FB
		1600	HW2M316FB	HW2M416FB
		2000	HW2M320FB	HW2M420FB
		2500	HW2M325FB	HW2M425FB
 HW2S425FB	66 kA	630	HW2E306FB	HW2E406FB
		800	HW2E308FB	HW2E408FB
		1000	HW2E310FB	HW2E410FB
		1250	HW2E312FB	HW2E412FB
		1600	HW2E316FB	HW2E416FB
		2000	HW2E320FB	HW2E420FB
		2500	HW2E325FB	HW2E425FB
HW2S425FB	100 kA	630	HW2S306FB	HW2S406FB
		800	HW2S308FB	HW2S408FB
		1000	HW2S310FB	HW2S410FB
		1250	HW2S312FB	HW2S412FB
		1600	HW2S316FB	HW2S416FB
		2000	HW2S320FB	HW2S420FB
		2500	HW2S325FB	HW2S425FB



**Fixed air circuit breakers for HW4 sentinel electronic trip unit**

	Icu 380 – 440 V~	In (A)	3 poles	4 poles
 HW4P340FB	66 kA	1000	HW4E310FB	HW4E410FB
		1250	HW4E312FB	HW4E412FB
		1600	HW4E316FB	HW4E416FB
		2000	HW4E320FB	HW4E420FB
		2500	HW4E325FB	HW4E425FB
		3200	HW4E332FB	HW4E432FB
		4000	HW4E340FB	HW4E440FB
		 HW4P440FB	85 kA	1000
1250	HW4S312FB			HW4S412FB
1600	HW4S316FB			HW4S416FB
2000	HW4S320FB			HW4S420FB
2500	HW4S325FB			HW4S425FB
3200	HW4S332FB			HW4S432FB
4000	HW4S340FB			HW4S440FB
	120 kA			1000
		1250	HW4P312FB	HW4P412FB
		1600	HW4P316FB	HW4P416FB
		2000	HW4P320FB	HW4P420FB
		2500	HW4P325FB	HW4P425FB
		3200	HW4P332FB	HW4P432FB
		4000	HW4P340FB	HW4P440FB



Fixed air circuit breakers for HW1 sentinel Energy electronic trip unit

	Icu 380 – 440 V~	In (A)	3 poles	4 poles
 HW1E316FE	42 kA	400	HW1N304FE	HW1N404FE
		630	HW1N306FE	HW1N406FE
		800	HW1N308FE	HW1N408FE
		1000	HW1N310FE	HW1N410FE
		1250	HW1N312FE	HW1N412FE
		1600	HW1N316FE	HW1N416FE
 HW1E416FE	55 kA	400	HW1M304FE	HW1M404FE
		630	HW1M306FE	HW1M406FE
		800	HW1M308FE	HW1M408FE
		1000	HW1M310FE	HW1M410FE
		1250	HW1M312FE	HW1M412FE
		1600	HW1M316FE	HW1M416FE
	66 kA	400	HW1E304FE	HW1E404FE
		630	HW1E306FE	HW1E406FE
		800	HW1E308FE	HW1E408FE
		1000	HW1E310FE	HW1E410FE
		1250	HW1E312FE	HW1E412FE
		1600	HW1E316FE	HW1E416FE

Fixed air circuit breakers for HW2 sentinel Energy electronic trip unit

	Icu 380 – 440 V~	In (A)	3 poles	4 poles
 HW2S325FE	55 kA	630	HW2M306FE	HW2M406FE
		800	HW2M308FE	HW2M408FE
		1000	HW2M310FE	HW2M410FE
		1250	HW2M312FE	HW2M412FE
		1600	HW2M316FE	HW2M416FE
		2000	HW2M320FE	HW2M420FE
		2500	HW2M325FE	HW2M425FE
 HW2S425FE	66 kA	630	HW2E306FE	HW2E406FE
		800	HW2E308FE	HW2E408FE
		1000	HW2E310FE	HW2E410FE
		1250	HW2E312FE	HW2E412FE
		1600	HW2E316FE	HW2E416FE
		2000	HW2E320FE	HW2E420FE
		2500	HW2E325FE	HW2E425FE
			100 kA	630
800	HW2S308FE			HW2S408FE
1000	HW2S310FE			HW2S410FE
1250	HW2S312FE			HW2S412FE
1600	HW2S316FE			HW2S416FE
2000	HW2S320FE			HW2S420FE
2500	HW2S325FE			HW2S425FE

**Fixed air circuit breakers for HW4 sentinel Energy electronic trip unit**

	Icu 380 – 440 V~	In (A)	3 poles	4 poles
 HW4P340FE	66 kA	1000	HW4E310FE	HW4E410FE
		1250	HW4E312FE	HW4E412FE
		1600	HW4E316FE	HW4E416FE
		2000	HW4E320FE	HW4E420FE
		2500	HW4E325FE	HW4E425FE
		3200	HW4E332FE	HW4E432FE
		4000	HW4E340FE	HW4E440FE
		 HW4P440FE	85 kA	1000
1250	HW4S312FE			HW4S412FE
1600	HW4S316FE			HW4S416FE
2000	HW4S320FE			HW4S420FE
2500	HW4S325FE			HW4S425FE
3200	HW4S332FE			HW4S432FE
4000	HW4S340FE			HW4S440FE
	120 kA			1000
		1250	HW4P312FE	HW4P412FE
		1600	HW4P316FE	HW4P416FE
		2000	HW4P320FE	HW4P420FE
		2500	HW4P325FE	HW4P425FE
		3200	HW4P332FE	HW4P432FE
		4000	HW4P340FE	HW4P440FE

**HW1 fixed switch-disconnectors**

	In (A)	3 poles	4 poles
	400	HW1W304FS	HW1W404FS
	630	HW1W306FS	HW1W406FS
	800	HW1W308FS	HW1W408FS
	1000	HW1W310FS	HW1W410FS
	1250	HW1W312FS	HW1W412FS
HW1W416FS	1600	HW1W316FS	HW1W416FS

**HW2 fixed switch-disconnectors**



	In (A)	3 poles	4 poles
	630	HW2W306FS	HW2W406FS
	800	HW2W308FS	HW2W408FS
	1000	HW2W310FS	HW2W410FS
	1250	HW2W312FS	HW2W412FS
	1600	HW2W316FS	HW2W416FS
HW2W325FS	2000	HW2W320FS	HW2W420FS
	2500	HW2W325FS	HW2W425FS

**HW4 fixed switch-disconnectors**



	In (A)	3 poles	4 poles	
	1000	HW4W310FS	HW4W410FS	
	1250	HW4W312FS	HW4W412FS	
	1600	HW4W316FS	HW4W416FS	
	2000	HW4W320FS	HW4W420FS	
	HW4W440FS	2500	HW4W325FS	HW4W425FS
		3200	HW4W332FS	HW4W432FS
		4000	HW4W340FS	HW4W440FS



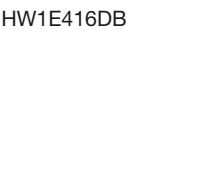

## Drawout air circuit breakers for HW1 sentinel electronic trip unit (moving part)

	Icu 380 – 440 V~	In (A)	3 poles	4 poles
 HW1E316DB	42 kA	400	HW1N304DB	HW1N404DB
		630	HW1N306DB	HW1N406DB
		800	HW1N308DB	HW1N408DB
		1000	HW1N310DB	HW1N410DB
		1250	HW1N312DB	HW1N412DB
		1600	HW1N316DB	HW1N416DB
 HW1E416DB	55 kA	400	HW1M304DB	HW1M404DB
		630	HW1M306DB	HW1M406DB
		800	HW1M308DB	HW1M408DB
		1000	HW1M310DB	HW1M410DB
		1250	HW1M312DB	HW1M412DB
		1600	HW1M316DB	HW1M416DB
 HW1E416DB	66 kA	400	HW1E304DB	HW1E404DB
		630	HW1E306DB	HW1E406DB
		800	HW1E308DB	HW1E408DB
		1000	HW1E310DB	HW1E410DB
		1250	HW1E312DB	HW1E412DB
		1600	HW1E316DB	HW1E416DB



## Drawout air circuit breakers for HW2 sentinel electronic trip unit (moving part)

	Icu 380 – 440 V~	In (A)	3 poles	4 poles
 HW2S325DB	55 kA	630	HW2M306DB	HW2M406DB
		800	HW2M308DB	HW2M408DB
		1000	HW2M310DB	HW2M410DB
		1250	HW2M312DB	HW2M412DB
		1600	HW2M316DB	HW2M416DB
		2000	HW2M320DB	HW2M420DB
		2500	HW2M325DB	HW2M425DB
 HW2S425DB	66 kA	630	HW2E306DB	HW2E406DB
		800	HW2E308DB	HW2E408DB
		1000	HW2E310DB	HW2E410DB
		1250	HW2E312DB	HW2E412DB
		1600	HW2E316DB	HW2E416DB
		2000	HW2E320DB	HW2E420DB
		2500	HW2E325DB	HW2E425DB
		 HW2S425DB	100 kA	630
800	HW2S308DB			HW2S408DB
1000	HW2S310DB			HW2S410DB
1250	HW2S312DB			HW2S412DB
1600	HW2S316DB			HW2S416DB
2000	HW2S320DB			HW2S420DB
2500	HW2S325DB			HW2S425DB



Drawout air circuit breakers for HW4 sentinel electronic trip unit (moving part)

Icu 380 – 440 V~	In (A)	3 poles	4 poles	
 HW4P340DB	66 kA	1000	HW4E310DB	HW4E410DB
	1250	HW4E312DB	HW4E412DB	
	1600	HW4E316DB	HW4E416DB	
	2000	HW4E320DB	HW4E420DB	
	2500	HW4E325DB	HW4E425DB	
	3200	HW4E332DB	HW4E432DB	
	4000	HW4E340DB	HW4E440DB	
 HW4P440DB	85 kA	1000	HW4S310DB	HW4S410DB
	1250	HW4S312DB	HW4S412DB	
	1600	HW4S316DB	HW4S416DB	
	2000	HW4S320DB	HW4S420DB	
	2500	HW4S325DB	HW4S425DB	
	3200	HW4S332DB	HW4S432DB	
	4000	HW4S340DB	HW4S440DB	
120 kA	1000	HW4P310DB	HW4P410DB	
	1250	HW4P312DB	HW4P412DB	
	1600	HW4P316DB	HW4P416DB	
	2000	HW4P320DB	HW4P420DB	
	2500	HW4P325DB	HW4P425DB	
	3200	HW4P332DB	HW4P432DB	
	4000	HW4P340DB	HW4P440DB	



Drawout air circuit breakers for HW6 sentinel electronic trip unit (moving part)

Icu 380 – 440 V~	In (A)	3 poles	4 poles	
 HW6L363DB	100 kA	3200	HW6L332DB	HW6L432DB
		4000	HW6L340DB	HW6L440DB
		5000	HW6L350DB	HW6L450DB
		6300	HW6L363DB	HW6L463DB
 HW6L463DB				

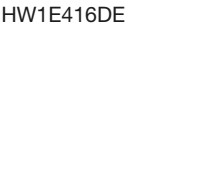

**Drawout air circuit breakers for HW1 sentinel Energy electronic trip unit (moving part)**

	Icu 380 – 440 V~	In (A)	3 poles	4 poles
 HW1E316DE	42 kA	400	HW1N304DE	HW1N404DE
		630	HW1N306DE	HW1N406DE
		800	HW1N308DE	HW1N408DE
		1000	HW1N310DE	HW1N410DE
		1250	HW1N312DE	HW1N412DE
		1600	HW1N316DE	HW1N416DE
 HW1E316DE	55 kA	400	HW1M304DE	HW1M404DE
		630	HW1M306DE	HW1M406DE
		800	HW1M308DE	HW1M408DE
		1000	HW1M310DE	HW1M410DE
		1250	HW1M312DE	HW1M412DE
		1600	HW1M316DE	HW1M416DE
 HW1E416DE	66 kA	400	HW1E304DE	HW1E404DE
		630	HW1E306DE	HW1E406DE
		800	HW1E308DE	HW1E408DE
		1000	HW1E310DE	HW1E410DE
		1250	HW1E312DE	HW1E412DE
		1600	HW1E316DE	HW1E416DE



**Drawout air circuit breakers for HW2 sentinel Energy electronic trip unit (moving part)**

	Icu 380 – 440 V~	In (A)	3 poles	4 poles
 HW2S325DE	55 kA	630	HW2M306DE	HW2M406DE
		800	HW2M308DE	HW2M408DE
		1000	HW2M310DE	HW2M410DE
		1250	HW2M312DE	HW2M412DE
		1600	HW2M316DE	HW2M416DE
		2000	HW2M320DE	HW2M420DE
		2500	HW2M325DE	HW2M425DE
 HW2S425DE	66 kA	630	HW2E306DE	HW2E406DE
		800	HW2E308DE	HW2E408DE
		1000	HW2E310DE	HW2E410DE
		1250	HW2E312DE	HW2E412DE
		1600	HW2E316DE	HW2E416DE
		2000	HW2E320DE	HW2E420DE
		2500	HW2E325DE	HW2E425DE
 HW2S425DE	100 kA	630	HW2S306DE	HW2S406DE
		800	HW2S308DE	HW2S408DE
		1000	HW2S310DE	HW2S410DE
		1250	HW2S312DE	HW2S412DE
		1600	HW2S316DE	HW2S416DE
		2000	HW2S320DE	HW2S420DE
		2500	HW2S325DE	HW2S425DE

Drawout air circuit breakers for HW4 sentinel Energy electronic trip unit (moving part)

	Icu 380 – 440 V~	In (A)	3 poles	4 poles
 HW4P340DE	66 kA	1000	HW4E310DE	HW4E410DE
		1250	HW4E312DE	HW4E412DE
		1600	HW4E316DE	HW4E416DE
		2000	HW4E320DE	HW4E420DE
		2500	HW4E325DE	HW4E425DE
		3200	HW4E332DE	HW4E432DE
		4000	HW4E340DE	HW4E440DE
 HW4P440DE	85 kA	1000	HW4S310DE	HW4S410DE
		1250	HW4S312DE	HW4S412DE
		1600	HW4S316DE	HW4S416DE
		2000	HW4S320DE	HW4S420DE
		2500	HW4S325DE	HW4S425DE
		3200	HW4S332DE	HW4S432DE
		4000	HW4S340DE	HW4S440DE
	120 kA	1000	HW4P310DE	HW4P410DE
		1250	HW4P312DE	HW4P412DE
		1600	HW4P316DE	HW4P416DE
		2000	HW4P320DE	HW4P420DE
		2500	HW4P325DE	HW4P425DE
		3200	HW4P332DE	HW4P432DE
		4000	HW4P340DE	HW4P440DE

Drawout air circuit breakers for HW6 sentinel Energy electronic trip unit (complete product)

	Icu 380 – 440 V~	In (A)	3 poles	4 poles
 HE6L363DQMPAAAAAAAA	150 kA	6300	HE6L363DQMBAAAAAAAA Energy LSI Ultimate VCVC	HE6L463DQMBAAAAAAAA Energy LSI Ultimate VCVC
			HE6L363DQMPAAAAAAAA Energy LSI Ultimate HCHC	HE6L463DQMPAAAAAAAA Energy LSI Ultimate HCHC
 HE6L463DQMPAAAAAAAA				

**HW1 drawout switch-disconnectors (moving part)**

	In (A)	3 poles	4 poles
	400	HW1W304DS	HW1W404DS
	630	HW1W306DS	HW1W406DS
	800	HW1W308DS	HW1W408DS
	1000	HW1W310DS	HW1W410DS
	1250	HW1W312DS	HW1W412DS
	HW1W316DS	1600	HW1W316DS



**HW2 drawout switch-disconnectors (moving part)**

	In (A)	3 poles	4 poles	
	630	HW2W306DS	HW2W406DS	
	800	HW2W308DS	HW2W408DS	
	1000	HW2W310DS	HW2W410DS	
	1250	HW2W312DS	HW2W412DS	
	HW2W425DS	1600	HW2W316DS	HW2W416DS
	2000	HW2W320DS	HW2W420DS	
	2500	HW2W325DS	HW2W425DS	

**HW4 drawout switch-disconnectors (moving part)**

	In (A)	3 poles	4 poles	
	1000	HW4W310DS	HW4W410DS	
	1250	HW4W312DS	HW4W412DS	
	1600	HW4W316DS	HW4W416DS	
	2000	HW4W320DS	HW4W420DS	
	HW4W340DS	2500	HW4W325DS	HW4W425DS
	3200	HW4W332DS	HW4W432DS	
	4000	HW4W340DS	HW4W440DS	

**HW6 drawout switch-disconnectors (complete product)**

	In (A)	3 poles	4 poles
	6300	HE6W363DSABAAAAAAA VCVC	HE6W463DSABAAAAAAA VCVC
		HE6W363DSAPAAAAAAA HCHC	HE6W463DSAPAAAAAAA HCHC
			
HE6W363DSAPAAAAAAA HCHC			

**Chassis for air circuit breakers or switch-disconnectors - HW1 drawout version (fixed part)**

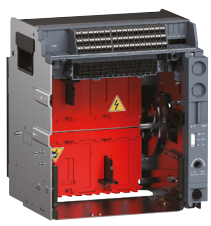
	3 poles	4 poles
	HW1C3EH	HW1C4EH

HW1C3EH

**Chassis for air circuit breakers or switch-disconnectors - HW2 drawout version (fixed part)**

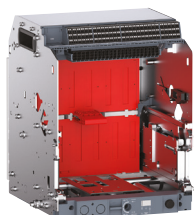
	3 poles	4 poles
	HW2C3SH	HW2C4SH

HW2C3SH

**Chassis for air circuit breakers or switch-disconnectors - HW4 drawout version (fixed part)**

	3 poles	4 poles
	HW4C3PH	HW4C4PH

HW4C3PH

**sentinel LI electronic trip unit**

	<b>Protection</b>	<b>Reference</b>
	Long Time Delay and Instantaneous	HWW450H

HWW450H

**sentinel LSI electronic trip unit**

	<b>Protection</b>	<b>Reference</b>
	Long Time Delay, Short Time Delay and Instantaneous	HWW451H

HWW451H

**sentinel LSIG electronic trip unit**

	<b>Protection</b>	<b>Reference</b>
	Long Time Delay, Short Time Delay, Instantaneous and Earth Protection	HWW452H

HWW452H

sentinel Energy LSI electronic trip unit

Protection	Reference
Long Time Delay, Short Time Delay and Instantaneous	HWW453H



HWW453H

sentinel Energy LSIG electronic trip unit

Protection	Reference
Long Time Delay, Short Time Delay, Instantaneous and Earth Protection	HWW454H



HWW454H

Rating plug for sentinel and sentinel Energy electronic trip unit

In	Size				Reference (factory-assembled)	Reference (separate accessory)
	HW1	HW2	HW4	HW6		
400 A	■				HWW464H	HWW464HSA
630 A	■	■			HWW465H	HWW465HSA
800 A	■	■			HWW466H	HWW466HSA
1000 A	■	■	■		HWW467H	HWW467HSA
1250 A	■	■	■		HWW468H	HWW468HSA
1600 A	■	■	■		HWW469H	HWW469HSA
2000 A		■	■		HWW470H	HWW470HSA
2500 A		■	■		HWW471H	HWW471HSA
3200 A			■	■	HWW472H	HWW472HSA
4000 A			■	■	HWW473H	HWW473HSA
5000 A				■	HWW474H	HWW474HSA
6300 A				■	HWW475H	HWW475HSA



HWW473H



**Meter Plus rating plug for sentinel Energy electronic trip unit**

	In	Size				Reference (factory-assembled)	Reference (separate accessory)
		HW1	HW2	HW4	HW6		
 HWW673H	400 A	■				HWW664H	HWW664HSA
	630 A	■	■			HWW665H	HWW665HSA
	800 A	■	■			HWW666H	HWW666HSA
	1000 A	■	■	■		HWW667H	HWW667HSA
	1250 A	■	■	■		HWW668H	HWW668HSA
	1600 A	■	■	■		HWW669H	HWW669HSA
	2000 A		■	■		HWW670H	HWW670HSA
	2500 A		■	■		HWW671H	HWW671HSA
	3200 A			■	■	HWW672H	HWW672HSA
	4000 A			■	■	HWW673H	HWW673HSA
	5000 A				■	HWW674H	HWW674HSA
	6300 A				■	HWW675H	HWW675HSA

**Harmonic rating plug for sentinel Energy electronic trip unit**

	In	Size				Reference (factory-assembled)	Reference (separate accessory)
		HW1	HW2	HW4	HW6		
 HWW693H	400 A	■				HWW684H	HWW684HSA
	630 A	■	■			HWW685H	HWW685HSA
	800 A	■	■			HWW686H	HWW686HSA
	1000 A	■	■	■		HWW687H	HWW687HSA
	1250 A	■	■	■		HWW688H	HWW688HSA
	1600 A	■	■	■		HWW689H	HWW689HSA
	2000 A		■	■		HWW690H	HWW690HSA
	2500 A		■	■		HWW691H	HWW691HSA
	3200 A			■	■	HWW692H	HWW692HSA
	4000 A			■	■	HWW693H	HWW693HSA
	5000 A				■	HWW694H	HWW694HSA
	6300 A				■	HWW695H	HWW695HSA

Advanced rating plug for sentinel Energy electronic trip unit

	In	Size				Reference (factory-assembled)	Reference (separate accessory)
		HW1	HW2	HW4	HW6		
 HWW709H	400 A	■				HWW704H	HWW704HSA
	630 A	■	■			HWW705H	HWW705HSA
	800 A	■	■			HWW706H	HWW706HSA
	1000 A	■	■	■		HWW707H	HWW707HSA
	1250 A	■	■	■		HWW708H	HWW708HSA
	1600 A	■	■	■		HWW709H	HWW709HSA
	2000 A		■	■		HWW710H	HWW710HSA
	2500 A		■	■		HWW711H	HWW711HSA
	3200 A			■	■	HWW712H	HWW712HSA
	4000 A			■	■	HWW713H	HWW713HSA
	5000 A				■	HWW714H	HWW714HSA
	6300 A				■	HWW715H	HWW715HSA

Ultimate rating plug for sentinel Energy electronic trip unit

	In	Size				Reference (factory-assembled)	Reference (separate accessory)
		HW1	HW2	HW4	HW6		
 HWW729H	400 A	■				HWW724H	HWW724HSA
	630 A	■	■			HWW725H	HWW725HSA
	800 A	■	■			HWW726H	HWW726HSA
	1000 A	■	■	■		HWW727H	HWW727HSA
	1250 A	■	■	■		HWW728H	HWW728HSA
	1600 A	■	■	■		HWW729H	HWW729HSA
	2000 A		■	■		HWW730H	HWW730HSA
	2500 A		■	■		HWW731H	HWW731HSA
	3200 A			■	■	HWW732H	HWW732HSA
	4000 A			■	■	HWW733H	HWW733HSA
	5000 A				■	HWW734H	HWW734HSA
	6300 A				■	HWW735H	HWW735HSA

### SH shunt trip coil



HWX023H

Voltage	Inrush current (VA)	Holding current (VA)	Reference (factory-assembled)	Reference (separate accessory)
24 - 30 V AC/DC	300 (200 ms)	5	HWX020H	HWX020HSA
48 - 60 V AC/DC	300 (200 ms)	5	HWX021H	HWX021HSA
100 - 130 V AC/DC	200 (200 ms)	5	HWX022H	HWX022HSA
200 - 250 V AC/DC	200 (200 ms)	5	HWX023H	HWX023HSA
380 - 480 V AC	200 (200 ms)	5	HWX024H	HWX024HSA

### CC closing coil



HWX026H

Voltage	Inrush current (VA)	Holding current (VA)	Reference (factory-assembled)	Reference (separate accessory)
24 - 30 V AC/DC	300 (200 ms)	5	HWX025H	HWX025HSA
48 - 60 V AC/DC	300 (200 ms)	5	HWX026H	HWX026HSA
100 - 130 V AC/DC	200 (200 ms)	5	HWX027H	HWX027HSA
200 - 250 V AC/DC	200 (200 ms)	5	HWX028H	HWX028HSA
380 - 480 V AC	200 (200 ms)	5	HWX029H	HWX029HSA

### UV undervoltage release coil



HWX033H

Voltage	Inrush current (VA)	Holding current (VA)	Reference (factory-assembled)	Reference (separate accessory)
24 - 30 V AC/DC	300 (200 ms)	5	HWX030H	HWX030HSA
48 - 60 V AC/DC	300 (200 ms)	5	HWX031H	HWX031HSA
100 - 130 V AC/DC	200 (200 ms)	5	HWX032H	HWX032HSA
200 - 250 V AC/DC	200 (200 ms)	5	HWX033H	HWX033HSA
380 - 480 V AC	200 (200 ms)	5	HWX034H	HWX034HSA

### UVTC Undervoltage Time Delay Controller





HWY033H



Voltage	Reference (factory-assembled)	Reference (separate accessory)
24 - 30 V AC/DC	-	HWY030H
48 - 60 V AC/DC	-	HWY031H
200 - 250 V AC	-	HWY033H
380 - 480 V AC	-	HWY034H

MO charging Motor

For AC voltage

	Voltage	Inrush current (A)	Holding current (A)	Size HW1	HW2 / HW4 / HW6	Reference (factory-assembled)	Reference (separate accessory)
 HWX006H	24 V AC	25	9.6	■		HWX001H	HWX001HSA
	24 V AC	20	8.2		■	HWX011H	HWX011HSA
	48 - 60 V AC	12.5	4.8	■		HWX002H	HWX002HSA
	48 V AC	12	4.2		■	HWX012H	HWX012HSA
	100 - 130 V AC	5.2	2	■		HWX003H	HWX003HSA
	100 - 130 V AC	5.1	2.3		■	HWX013H	HWX013HSA
 HWX014H	200 - 250 V AC	2.7	1	■		HWX004H	HWX004HSA
	200 - 250 V AC	3.1	1		■	HWX014H	HWX014HSA
	380 - 400 V AC	1.5	0.6	■		HWX005H	HWX005HSA
	380 - 400 V AC	1.5	0.6		■	HWX015H	HWX015HSA
	415 - 450 V AC	1.4	0.5	■		HWX006H	HWX006HSA
	415 - 450 V AC	1.4	0.5		■	HWX016H	HWX016HSA

For DC voltage

	Voltage	Inrush current (A)	Holding current (A)	Size HW1	HW2 / HW4 / HW6	Reference (factory-assembled)	Reference (separate accessory)
 HWX702H	24 V DC	25	9.6	■		HWX701H	HWX701HSA
	24 V DC	20	8.2		■	HWX711H	HWX711HSA
	48 - 60 V DC	12.5	4.8	■		HWX702H	HWX702HSA
	48 V DC	12	4.2		■	HWX712H	HWX712HSA
	100 - 130 V DC	5.2	2	■		HWX703H	HWX703HSA
	100 - 130 V DC	5.1	2.3		■	HWX713H	HWX713HSA
 HWX713H	200 - 250 V DC	2.7	1	■		HWX704H	HWX704HSA
	200 - 250 V DC	3.1	1		■	HWX714H	HWX714HSA

**AX Auxiliary Contact**

	Size HW1	HW2 / HW4 / HW6	Reference (factory-assembled)	Reference (separate accessory)
Auxiliary contact	■		HWX040H	HWX040HSA
Auxiliary contact		■	HWX042H	HWX042HSA
Low level auxiliary contact	■		HWX041H	HWX041HSA
Low level auxiliary contact		■	HWX043H	HWX043HSA



HWX040H

**FS Fault trip contact**

	Size HW1	HW2 / HW4 / HW6	Reference (factory-assembled)	Reference (separate accessory)
FS Fault trip contact	■		HWX047H	HWX047HSA
FS Fault trip contact		■	HWX048H	HWX048HSA

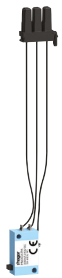

HWX047H

**OAC output alarm contacts module**

	Reference (factory-assembled)	Reference (separate accessory)
OAC output alarm contacts module	HWX090H	HWX090HSA



HWX090H

**PS Position contact**

**For drawout version**

		Reference (factory-assembled)	Reference (separate accessory)
	Position contact	HWX050H	HWX050HSA
	Low level position contacts	HWX051H	HWX051HSA

HWX050H

**RTC Ready-to-Close contact**

		Size HW1	HW2 / HW4 / HW6	Reference (factory-assembled)	Reference (separate accessory)
	RTC Ready-to-Close contact	■		HWX091H	HWX091HSA
	RTC Ready-to-Close contact		■	HWX092H	HWX092HSA



HWX091H

**CYC Operation Cycle Counter**

		Size HW1	HW2 / HW4 / HW6	Reference (factory-assembled)	Reference (separate accessory)
	On / Off cycle counter	■		HWX070H	HWX070HSA
	On / Off cycle counter		■	HWX071H	HWX071HSA

HWX070H

**WIP wrong insertion preventer for drawout circuit breaker**

		Size HW1	HW2 / HW4 / HW6	Reference (factory-assembled)	Reference (separate accessory)
	WIP wrong insertion preventer for drawout circuit breaker	■		-	HWY276H
	WIP wrong insertion preventer for drawout circuit breaker		■	-	HWY277H
					

HWY276H

**RI open door racking interlock**

For drawout version

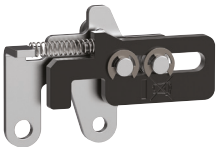
		Size HW1	HW2 / HW4 / HW6	Reference (factory-assembled)	Reference (separate accessory)
	RI open door racking interlock	■		-	HWY238H
	RI open door racking interlock		■	-	HWY239H

HWY238H

**Locking of the circuit breaker in OFF by OLP padlock and OLK key lock**

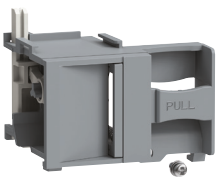
		Size HW1	HW2 / HW4 / HW6	Reference (factory-assembled)	Reference (separate accessory)
	OLP type padlock locking device (without padlock)	■		HWY269H	HWY269HSA
	OLP type padlock locking device (without padlock)		■	HWY265H	HWY265HSA
	Locking device with OLK type key lock (without lock)	■		HWY260H	HWY260HSA
	Locking device with OLK type key lock (without lock)		■	HWY261H	HWY261HSA

HWY269H

Locking of the position of the circuit breaker in its CL chassis

	Size HW1	HW2 / HW4 / HW6	Reference (factory-assembled)	Reference (separate accessory)
 Locking device with key locks	■		HWY270H	HWY270HSA
 Locking device with key locks		■	HWY271H	HWY271HSA

HWY270H

Ronis type key lock

	Size HW1	HW2 / HW4 / HW6	Reference (factory-assembled)	Reference (separate accessory)
 Type 1 - K1L1/L4	■	■	-	HWY701
Type 2 - K2L2/L4/L5	■	■	-	HWY702
Type 3 - K3L3/L5	■	■	-	HWY703
Type 4 - K4L4	■	■	-	HWY704
Type 5 - K5L5	■	■	-	HWY705

HWY701

MI mechanical interlock

	Size HW1	HW2 / HW4 / HW6	Reference (factory-assembled)	Reference (separate accessory)
 For fixed version - 2S	■		-	HWY224H
For fixed version - 2S		■	-	HWY226H
For drawout version - 2S	■		-	HWY225H
For drawout version - 2S		■	-	HWY227H
Set with a 1.5-metre-long cable	■	■	-	HWY218H
Set with a 3-metre-long cable	■	■	-	HWY228H

HWY234H

PBC push-button cover

	Size HW1	HW2 / HW4 / HW6	Reference (factory-assembled)	Reference (separate accessory)
 PBC push-button cover	■		HWY089H	HWY089HSA
PBC push-button cover		■	HWY090H	HWY090HSA

HWY089H



**VCA vertical connectors**

	Number of poles	Position	Size HW1	HW2 / HW4 / HW6	Reference (factory-assembled)	Reference (separate accessory)
	3 poles	top / bottom	■		-	HWY005H
	4 poles	top / bottom	■		-	HWY006H

HWY005H

**SP spreaders**

	Number of poles	Position	Size HW1	HW2 / HW4 / HW6	Reference (factory-assembled)	Reference (separate accessory)
	3 poles	top / bottom	■		-	HWY001H
	4 poles	top / bottom	■		-	HWY002H

HWY001H

**IB interphase barriers**

	Number of poles	Version	Size HW1	HW2 / HW4 / HW6	Reference (delivered with the circuit breaker)	Reference (separate accessory)
	3 poles	fixed/drawout	■		HWY240H	HWY240HSA
	4 poles	fixed/drawout	■		HWY241H	HWY241HSA
	3 poles	fixed		■	HWY246H	HWY246HSA
	4 poles	fixed		■	HWY247H	HWY247HSA
	3 poles	drawout		■	HWY248H	HWY248HSA
	4 poles	drawout		■	HWY249H	HWY249HSA

HWY241H

Rear vertical / horizontal RC connections



HWY048H

Number of poles	Position	Orientation	Rating (A)	Size				Reference (factory-assembled)	Reference (separate accessory)
				HW1	HW2	HW4	HW6		
3 poles	top / bottom	vertical / horizontal		■				HWY048H	HWY048HSA
4 poles	top / bottom	vertical / horizontal		■				HWY049H	HWY049HSA
3 poles	top / bottom	vertical / horizontal	630 - 2500		■			HWY160H	HWY160HSA
4 poles	top / bottom	vertical / horizontal	630 - 2500		■			HWY161H	HWY161HSA
3 poles	top / bottom	vertical / horizontal	1000 - 2500			■		HWY068H	HWY068HSA
4 poles	top / bottom	vertical / horizontal	1000 - 2500			■		HWY069H	HWY069HSA
3 poles	top / bottom	vertical / horizontal	3200 - 4000			■		HWY168H	HWY168HSA
4 poles	top / bottom	vertical / horizontal	3200 - 4000			■		HWY169H	HWY169HSA
3 poles	top / bottom	horizontal	3200 - 6300				■	HWY078H	-
4 poles	top / bottom	horizontal	3200 - 6300				■	HWY079H	-
3 poles	top / bottom	vertical	3200 - 6300				■	HWY076H	-
4 poles	top / bottom	vertical	3200 - 6300				■	HWY077H	-

**Rear vertical / horizontal RC connections for unimes H distribution boards**

	Number of poles	Position	Size			Reference (factory-assembled)	Reference (separate accessory)
			HW1	HW2	HW4 / HW6		
 HWY150H	3 poles	top / bottom	■			HWY150H	HWY150HSA
	4 poles	top / bottom	■			HWY151H	HWY151HSA
	3 poles	top / bottom		■		HWY162H	HWY162HSA
	4 poles	top / bottom		■		HWY163H	HWY163HSA

**Rear vertical / horizontal long RC connections for unimes H distribution boards**

	Number of poles	Position	Size HW1	HW2 / HW4 / HW6	Reference (factory-assembled)	Reference (separate accessory)
4 poles	top / bottom	■		HWY149H	HWY149HSA	

HWY148H

FC front connections

For drawout version

	Number of poles	Position	Size HW1	HW2 / HW4 / HW6	Reference (factory-assembled)	Reference (separate accessory)
	3 poles	top / bottom	■		HWY044H	HWY044HSA
	4 poles	top / bottom	■		HWY045H	HWY045HSA
	3 poles	bottom short	■		HWY046H	HWY046HSA
	4 poles	bottom short	■		HWY047H	HWY047HSA

HWY044H

For fixed version

	Number of poles	Position	Size HW1	HW2 / HW4 / HW6	Reference (factory-assembled)	Reference (separate accessory)
	3 poles	top / bottom	■		HWY040H	HWY040HSA
	4 poles	top / bottom	■		HWY041H	HWY041HSA

HWY040H

For drawout version in unimes H distribution board

	Number of poles	Position	Size HW1	HW2 / HW4 / HW6	Reference (factory-assembled)	Reference (separate accessory)
	3 poles	top / bottom	■		HWY144H	HWY144HSA
	4 poles	top / bottom	■		HWY145H	HWY145HSA

HWY144H

For fixed version in unimes H distribution board

	Number of poles	Position	Size HW1	HW2 / HW4 / HW6	Reference (factory-assembled)	Reference (separate accessory)
	3 poles	top / bottom	■		HWY140H	HWY140HSA
	4 poles	top / bottom	■		HWY141H	HWY141HSA

HWY140H

## TC terminal cover

	Version	Number of poles	Size			Reference (factory-assembled)	Reference (separate accessory)
			HW1	HW2	HW4 / HW6		
 HWY095H	Drawout	3 poles	■			HWY095H	HWY095HSA
	Drawout	4 poles	■			HWY096H	HWY096HSA
	Fixed	3 / 4 poles		■		HWY097H	HWY097HSA
	Drawout	3 / 4 poles		■		HWY098H	HWY098HSA
	Fixed	3 / 4 poles			■	HWY099H	HWY099HSA
	Drawout	3 / 4 poles			■	HWY100H	HWY100HSA

## DF door flange

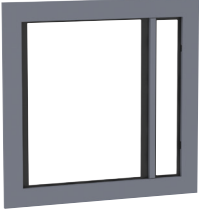
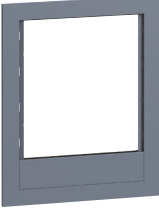
	Version	Door thickness	Size			Reference (factory-assembled)	Reference (separate accessory)
			HW1	HW2	HW4 / HW6		
 HWY281H	Fixed	thin (Quadro system)	■			-	HWY280H
		thick (Univers N and Unimes H systems)	■			-	HWY282H
	Drawout	thin (Quadro system)	■			-	HWY281H
		thick (Univers N and Unimes H systems)	■			-	HWY283H
 HWY286H	Fixed	thin (Quadro system)		■		-	HWY284H
		thick (Univers N and Unimes H systems)		■		-	HWY286H
	Drawout	thin (Quadro system)		■		-	HWY285H
		thick (Univers N and Unimes H systems)		■		-	HWY287H
	Fixed	thin (Quadro system)			■	-	HWY288H
		thick (Univers N and Unimes H systems)			■	-	HWY290H
	Drawout	thin (Quadro system)			■	-	HWY289H
		thick (Univers N and Unimes H systems)			■	-	HWY291H

## Cut-off chamber cover

### For fixed version

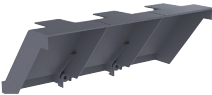
	Number of poles	Size HW1	HW2 / HW4 / HW6	Reference (factory-assembled)	Reference (separate accessory)
 HWY958H	3 poles	■		-	HWY958H
	4 poles	■		-	HWY959H

ENCT External Neutral Sensor

		Size				Reference (factory-assembled)	Reference (separate accessory)
		HW1	HW2	HW4	HW6		
 HWY970H	ENCT External Neutral Sensor	■				-	HWY970H
	ENCT External Neutral Sensor		■			-	HWY971H
	ENCT External Neutral Sensor			■		-	HWY972H
	ENCT External Neutral Sensor				■	-	HWY973H
	Cable adapter for external neutral sensor	■	■	■	■ <sup>(1)</sup>		HWY980H
	Cable adapter for external neutral sensor				■	-	HWY981H

(1) : Limited to 50% of neutral

**TB connection terminal block**



HWY951H





	<b>Reference (factory-assembled)</b>	<b>Reference (separate accessory)</b>
Connection terminal block A-type 6/3 TB	HWY950H	HWY950HSA
Connection terminal block type B 6/6 TB	HWY951H	HWY951HSA
Connection terminal block type C 2 x 6/3 TB	HWY952H	HWY952HSA

Communication modules

		Reference (factory-assembled)	Reference (separate accessory)
	Modbus-RTU communication module	HWY965H	HWY965HSA
	Modbus-TCP communication module	HWY966H	HWY966HSA

HWY965H

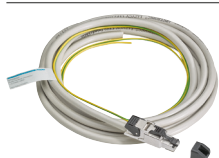
Modbus-RTU cables

			Reference (factory-assembled)	Reference (separate accessory)
	RJ45 - RJ45	0.2 m	-	HTG480H
		1 m	-	HTG481H
		2 m	-	HTG482H
		5 m	-	HTG484H
	RJ45 - RJ45 with earth wire	1 m	-	HTG471H
		2 m	-	HTG472H
		5 m	-	HTG474H
	RJ45 with earth - bare wires	3 m	-	HTG465H
	Modbus cable	25 m	-	HTG485H
	120 Ohm RJ45 terminal resistor		-	HTG467H

Insulation module (INS)

		Reference (factory-assembled)	Reference (separate accessory)
	Insulation module (INS)	HWX060H	HWX060HSA

HWX060H



**Panel display**

		Reference (factory-assembled)	Reference (separate accessory)
	Panel display	-	HTD210H
	RJ9 adapter for panel display	-	HWY210H

HTD210H



HWY210H

**PSE position sensor**

**For drawout version**

	Size			Reference (factory-assembled)	Reference (separate accessory)
	HW1	HW2	HW4 / HW6		
	PSE position sensor	■		HWX057H	-
	PSE position sensor		■	HWX058H	-
	PSE position sensor			■	HWX059H

HWX057H



**ANSI**

American National Standards Institute. Each electrical protection corresponds to an ANSI code.

**CIP**

Communications interface port with the panel display.

**DHCP**

Dynamic Host Configuration Protocol. Dynamic Host Configuration Protocol used to manage IP addresses.

**ENCT**

External neutral current sensor.

**ENVA**

External neutral potential.

**GF**

Earth fault protection.

**HWF**

Internal protection against electronic failures in the trip unit (hardware failure).

**INST**

Instantaneous Protection.

**LTD**

Long Time Delay Protection.

**MCR**

Making Current Release. Automatic instantaneous protection upon closure of the power contacts for short-circuit fault.

**MHT**

Magnetic Hold trigger. Coil connected directly to the electronic trip unit, which activates the mechanical opening lock of the circuit breaker in case of electrical fault or action by an SH shunt trip coil or UV undervoltage release coil.

**OAC**

Output alarm contact.

**PF**

Power factor. Power factor.

**Breaking capacity**

The value of the prospective current that a switching device is capable of breaking at a stated voltage under prescribed conditions of use and behaviour.

Reference is generally made to the rated ultimate short-circuit (I<sub>cu</sub>) breaking capacity and to the service short-circuit breaking capacity (I<sub>cs</sub>).

**Rated ultimate short-circuit breaking capacity (I<sub>cu</sub>)**

Expressed in kA, it indicates the maximum breaking capacity of the circuit breaker. It is confirmed by a test sequence O - t - CO (according to IEC 60947-2) at I<sub>cu</sub>, followed by a test to prove that the circuit is correctly isolated. This test ensures safety for the user.

**PTA**

Overload pre-alarm.

**SNTP**

Simple Network Time Protocol. Used by a server managing the date and time of the communication network.

**STD**

Short Time Delay Protection.

**Thi**

Thermal image. Default setting of the Long time delay protection in accordance with IEC 60947-2.

**ZSI**

Zone selectivity.







**Hager Electro SAS**

132 Boulevard d'Europe  
BP3  
67210 OBERNAI CEDEX

[hager.com](http://hager.com)