

manual FW2

Wall- and Flush-mounting
cabinets Class I



:hager

Table of contents

1 About this manual	3
1.1 Subject of the manual	3
1.2 Warranty and Liability	3
1.3 Used symbols and trademarks	4
2 For your safety	5
2.1 Proper use	5
2.2 Requirements for authorised personnel	7
3 Technical data	8
3.1 Technical features	8
3.2 Power loss	12
4 The FW2 product range	14
4.1 Delivery form	14
4.2 Coding	15
4.3 Overview of enclosure product codes	16
5 Enclosures in detail	18
5.1 FWxxxF	18
5.2 FWxxxFB	19
5.3 FWxxxFBT	20
5.4 FWxxxFT	21
5.5 FWxxxW	22
5.6 FWxxxWT	23
6 Frames and doors features and accessories	24
6.1 Features	24
6.2 Door distance to interior fittings	24
6.3 FWxxxFD	26
6.4 Doors as spare parts	27
6.5 Door accessories	28
7 Enclosure features and accessories	29
7.1 Internal fittings	29
7.2 Accessories for internal fittings	31
7.3 Earthing protection	34
7.4 Cable entries	35
7.5 Cable strain relief	39
7.6 PEN terminals	40
8 Inspection and maintenance	41
8.1 Testing intervals for recurring tests	40
8.2 Minimum inspection/maintenance measures	42
8.3 Cleaning	44

9 Decommissioning, disassembly and disposal	45
9.1 Decommissioning	45
9.2 Disassembly and disposal	45
10 List of all product codes	46
11 Glossary	47

1. About this manual

These instructions are an integral part of the FW2 flush-mounted distribution board enclosure.

1.1. Subject of the manual

This document is intended for users of FW2 flush-mounted distribution board enclosures made by Hager. The instruction manual provides safety information for electrically skilled persons/the installer about the product's life cycle phases.

- Read and observe this manual before you start working on the enclosure or the switchgear and controlgear assembly
- Also observe the supplied assembly manual for the respective enclosure or enclosure accessories
- Store the manuals in a safe place. The authorised personnel must have access to the manuals at all times

1.2. Warranty and Liability

These instructions do not extend the Sales and Delivery Conditions of Hager. No new claims concerning the warranty or guarantee, which extend beyond the Sales and Delivery Conditions, can be derived from this instruction manual.

Liability note





Hager reserves the right to modify or supplement the product or the documentation at any time without prior notice. Hager assumes no liability for typographical errors and any damage which may arise from them.

1.3. Used symbols and trademarks

Structure of warning messages

Signal word 
Type and source of the danger! Consequences if the danger is ignored ➤ Measures for averting the danger

Danger levels in warning messages

Farbe	Signalwort	Consequences of non-compliance
	DANGER	Death, serious personal injury
	WARNING	Death or serious personal injury possible
	CAUTION	Personal injury
	ATTENTION	Property damage

Procedural instructions with a fixed order:

Step	Action
1	Procedural instruction step 1
2	Procedural instruction step 2

Additional symbols and their meaning

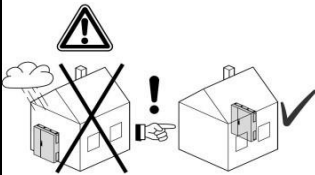
Symbol	Meaning
	The work must only be performed by an electrically skilled person.
	The product is intended for indoor installation or indoor use.

Visual representation	Meaning
1., 2., 3., ...	Numbered lists with a fixed order
-	Lists and procedural instructions without a fixed order
➤	Measure / procedural instruction for averting danger

2. For your safety

Avoid dangers. Adherence to the safety information in this section is a prerequisite for the safe assembly and use of the field distributor.

Also observe the safety information provided in other sections.

2.1. Proper use

The Hager FW2 distribution board is a range of flush-mounted and surface-mounted products with IP40 protection with door for residential and commercial buildings with a maximum supply current of 125A. FW2 flush enclosures are installed in the wall at a depth of 110 mm. The wall-mounted enclosures are 150 mm deep. They are available in 5 different heights and 3 different widths.

The Hager FW2 distribution board has its own internal mounting system, even if some parts, such as the door handle, come from the Univers system.

The Hager FW2 distribution board and its internal mounting system enable the implementation of switchgear and controlgear assemblies according to EN 61439 Part 3 (Distribution Boards intended to be operated by ordinary persons / DBO).

Fixed indoor/wall mounting

The FW2 distribution board is intended for stationary, indoor, flush mounting in walls/hollow walls and wall mounting. The operating conditions for indoor installation according to EN 61439 and the maximum ambient temperatures at the place of installation must be observed.

The FW2 distribution board complies with IP40 (flush and surface) when equipped with closed doors. The instructions in this manual for maintaining the degree of protection must be followed during installation.

The FW2 distribution board is available in protection class I (earth protection). The instructions in this manual regarding compliance with the degree of protection must be observed during installation. For more detailed information, refer to the technical data.

Intended use also includes:

- Reading and observing this manual, the installation manuals and the manuals for the internal fitting system
- Complying with the requirements for authorized personnel

Misuse

Any other or additional use as well as changes and modifications to the distribution board enclosure are considered to be misuse. Hager does not assume any liability for damages resulting from misuse.

Limitation of operating areas

There are certain areas where the FW2 enclosure must not be used to prevent hazards or damage to the enclosure.

The FW2 distribution box is not suitable for use:

- in areas where a higher degree of protection is required
- in areas where ATEX directives must be observed
- in locations where there is a risk of fire
- in corrosive environments. In particular, the enclosure and internal components may be damaged if used in chlorinated, sulphurous, acidic or saline environments

2.2. Requirements for authorized personnel

	<ul style="list-style-type: none"> - Only qualified electrically skilled persons may assemble, install, commission switchgear and controlgear assemblies, perform extensions, troubleshooting or maintenance and disassemble and dispose of them. - The qualified electrically skilled persons must have appropriate experience in initial testing and subsequent commissioning, troubleshooting and maintenance.
---	---

Product life cycle phase	Minimum training, qualifications or competence
Planning	Electrically skilled person, consultant electrical engineer
Transport, assembly, installation	Electrically skilled person
Commissioning	Electrically skilled person with appropriate testing experience
Operation	Short-circuit devices for operation by ordinary persons inside distribution boards for operation by ordinary persons according to EN 61439-3 (DBO): Ordinary persons All other components must be secured against use by ordinary persons
Inspection and maintenance	Electrically skilled person with appropriate testing experience
Extensions	Electrically skilled person, planning and documentation required
Disassembly, disposal	Electrically skilled person, only for clearly defined mechanical and electrical work: electrically instructed person

- An electrically skilled person by virtue of their professional training, skills and experience as well as knowledge of the relevant regulations can assess the work assigned to them and identify possible dangers
- An electrically instructed person must be sufficiently informed and supervised by an electrically skilled person. The instructed person must thus be capable of identifying risks and avoiding dangers as well as dangers due to electricity
- Anyone who is not an electrically skilled person or an electrically instructed person should always be considered as a non-professional, ordinary person
- Non-professional, ordinary persons should never perform work in electrical systems independently or on their own authority. Non-professional, ordinary persons may only operate short-circuit devices intended for use by ordinary persons according to EN 61439-3.

3. Technical data

3.1. Technical features

Intended use

Observing the technical data is important for ensuring the intended use.

Specifications for switchgear and control gear assemblies

The FW2 distribution board is equipped with its own internal fitting system and is suitable as a switchgear and controlgear assembly according to EN 61439-1/-3 for:

- Frequency $f_n = 50$ Hz
- Rated voltage $U_n = 230 / 400$ V
- Rated peak withstand current $I_{imp} = 4$ kV; overvoltage category III
- Rated insulation voltage $U_i = 400$ V
- Degree of pollution 3
- Minimum air clearance = 3 mm
- Minimum creepage distance = 5.6 mm

Rated current

I_{nA} max. 125 A

For brass terminals included into FT, FBT and WT references: I_{nA} max. 60 A

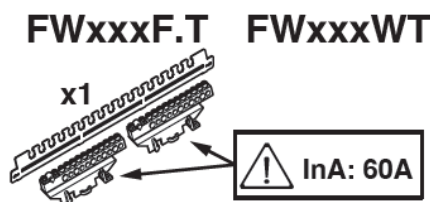

Short-circuit resistance I_{cc}

$I_{cc} < 10$ kA

Application

- Fixed, stationary installation
- Indoor installation
- For flush-mounted or hollow wall installation
- Protection against external mechanical influences: see "Impact protection"
- Equipped for use under normal operating conditions according to the EN 61439-3 standard (Distribution boards intended to be operated by ordinary persons/DBO), it can be operated by ordinary persons. Devices that must not be operated by ordinary persons must be marked as such by the installer in accordance with the standards or require the use of a key or tool. Additional requirements according to standard EN 61439 must be observed.

Dimensions

Surface:

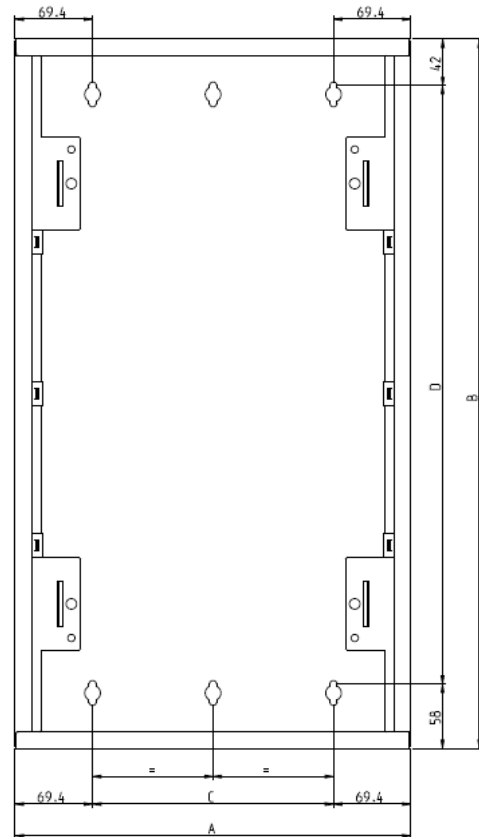
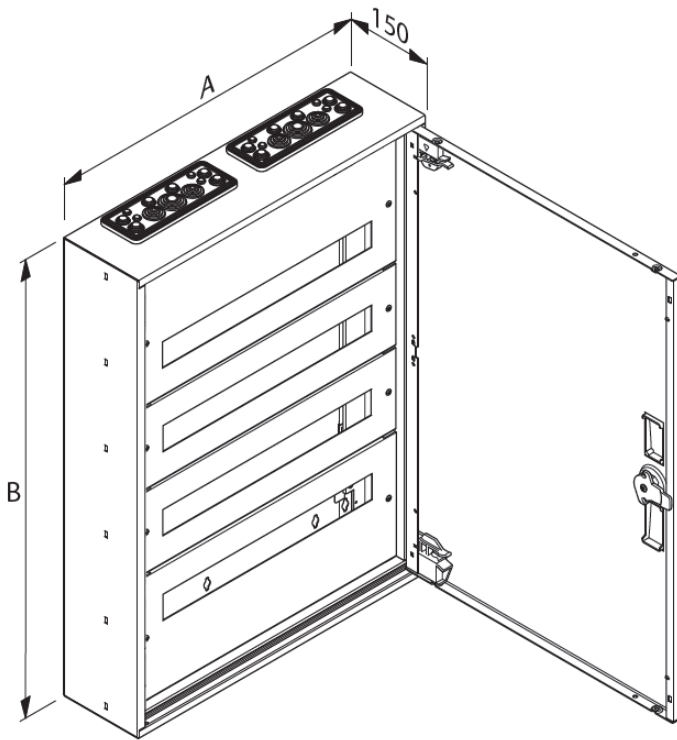

	A (mm)	B (mm)	C (mm)	D (mm)
FWx312Wx	355	641	216	541
FWx412Wx	355	791	216	691
FWx512Wx	355	941	216	841
FWx612Wx	355	1091	216	991
FWx324Wx	571	612	432	512
FWx424Wx	571	791	432	691
FWx524Wx	571	941	432	841
FWx624Wx	571	1091	432	991
FWx436Wx	787	791	648	691
FWx536Wx	787	941	648	841
FWx636Wx	787	1091	648	991
FWx736Wx	787	1241	648	1141

Wall mounting dims for surface enclosures

Flush:

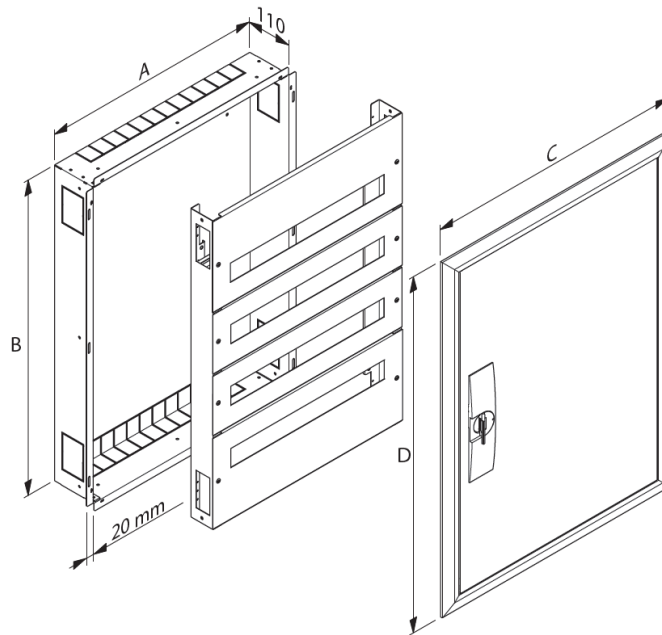

	A (mm)	B (mm)	C (mm)	D (mm)
FW312Fx	334	620	406	692
FW412Fx	334	770	406	842
FW512Fx	334	920	406	992
FW612Fx	334	1070	406	1142
FW324Fx	550	620	622	692
FW424Fx	550	770	622	842
FW524Fx	550	920	622	992
FW624Fx	550	1070	622	1142
FW436Fx	766	770	838	842
FW536Fx	766	920	838	992
FW636Fx	766	1070	838	1142
FW736Fx	766	1220	838	1292

Wall mounting dims for flush enclosures

Mechanical installation of devices /internal fittings

- Equipped with FW2 internal fitting system
- Compatible with some specific univers Z and univers FW accessories (such as door components)
- Internal fitting system pre-assembled in all enclosures

Protection class

Protection class I (grounded)



IP Protection

Flush

- IP40 with door
- IP2XC without door

Surface

- IP40 with door
- IP30 without door

Note: Observe the equipment's degree of protection.

Impact protection

- IK09 all around for an enclosure with closed door, except for the flange (excluded in the standard)
- IK07 for an enclosure equipped with an internal fitting system with covers but without a door

Colour

- Door, frame, covers and surface cabinet housing: RAL 9010 (pure white)
- Flush cabinet body and metal parts of the internal fitting system: grey and hot-dip galvanized

Materials

- Surface cabinet housing, covers, door and frame: 1 mm thick steel, powder-coated with epoxy polyester paint then baked
- Flush-mounted enclosure body in 1 mm thick hot-dip galvanized steel
- Material for plastic parts:
 - Polyethylene (PE-LD): flanges for surface cabinet and door plugs
 - Acrylnitril-Butadien-Styrol (ABS): door closing system, door hinges
- Vertical uprights in hot-dip galvanized steel, 1 mm thick
- DIN rails in hot-dip galvanized steel, 1,5 mm thick

Flush and surface housing parts are made of steel and are suitable for hollow-wall applications because they pass the glow-wire test at 850 °C. Surface-mount plastic/rubber cable entry flanges are not covered by the standard and are not required to meet it.

3.2. Power loss

3.2.1. Power loss for surface enclosures

Enclosure				Permissible power loss P_{perm} for enclosures without ventilation					
Type	Height H [mm]	Width W [mm]	Depth D [mm]	Temperature rise ΔT in flush mounted enclosures according IEC/TR 60890					% of enclosure height
				10 K	15 K	20 K	25 K	30 K	
				[W]	[W]	[W]	[W]	[W]	
FW312F..	620	334	110	9,7	16,0	23,0	30,3	38,0	75
				12,7	21,1	30,2	39,8	50,0	50
FW412F..	770	334	110	11,6	19,1	27,4	36,1	45,3	75
				15,3	25,3	36,2	47,8	60,0	50
FW512F..	920	334	110	13,4	22,2	31,7	41,9	52,6	75
				17,8	29,5	42,2	55,7	69,9	50
FW612F..	1070	334	110	15,3	25,3	36,1	47,7	59,8	75
				20,3	33,6	48,1	63,5	79,6	50
FW324F..	620	550	110	14,9	24,6	35,2	46,5	58,3	75
				18,7	31,0	44,3	58,5	73,4	50
FW424F..	770	550	110	17,4	28,9	41,3	54,5	68,3	75
				22,5	37,2	53,2	70,2	88,1	50
FW524F..	920	550	110	20,0	33,1	47,4	62,5	78,5	75
				26,2	43,3	61,9	81,7	102,5	50
FW624F..	1070	550	110	22,6	37,4	53,5	70,6	88,6	75
				29,8	49,3	70,5	93,1	116,7	50
FW436F..	770	766	110	23,7	39,2	56,1	74,0	92,9	75
				29,4	48,6	69,6	91,8	115,2	50
FW536F..	920	766	110	26,9	44,6	63,8	84,2	105,6	75
				34,2	56,6	80,9	106,8	134,0	50
FW636F..	1070	766	110	29,2	48,3	69,0	91,1	114,3	75
				39,4	65,3	93,4	123,3	154,6	50
FW736F..	1220	766	110	33,9	56,1	80,3	105,9	132,9	75
				46,1	76,3	109,2	144,1	180,8	50

3.2.2. Power loss for flush enclosures

Reference	Enclosure			Permissible power loss P_{perm} for enclosures without ventilation					
	Height H	Width W	Depth D	Temperature rise ΔT on wall mounted enclosures according IEC/TR 60890					% of enclosure height
	[mm]	[mm]	[mm]	10 K [W]	15 K [W]	20 K [W]	25 K [W]	30 K [W]	
FW312W.	641	355	150	13,8	22,8	32,6	43,1	54,0	75
				18,1	30,0	42,8	56,5	70,9	50
FW412W.	791	355	150	16,1	26,7	38,2	50,5	63,3	75
				21,4	35,4	50,6	66,8	83,8	50
FW512W.	941	355	150	18,5	30,7	43,8	57,9	72,6	75
				24,6	40,7	58,3	76,9	96,5	50
FW612W.	1091	355	150	20,9	34,6	49,4	65,2	81,8	75
				27,8	46,0	65,8	86,8	109,0	50
FW324W.	641	571	150	19,7	32,7	46,8	61,7	77,4	75
				24,9	41,2	58,9	77,7	97,5	50
FW424W.	791	571	150	22,7	37,6	53,8	71,1	89,2	75
				29,3	48,5	69,3	91,5	114,8	50
FW524W.	941	571	150	25,8	42,7	61,0	80,5	101,0	75
				33,6	55,7	79,6	105,1	131,9	50
FW624W.	1091	571	150	27,6	45,7	65,3	86,2	108,2	75
				38,0	63,0	90,1	118,9	149,2	50
FW436W.	791	787	150	29,0	48,0	68,7	90,6	113,7	75
				36,7	60,8	87,0	114,8	144,0	50
FW536W.	941	787	150	34,2	56,6	80,9	106,8	133,9	75
				44,4	73,5	105,1	138,7	174,0	50
FW636W.	1091	787	150	39,4	65,2	93,3	123,1	154,4	75
				52,3	86,6	123,9	163,5	205,1	50
FW736W.	1241	787	150	44,7	74,1	106,0	139,9	175,5	75
				60,5	100,2	143,2	189,1	237,2	50

In sum: Standards and regulations

- Tested according to EN 61439-1/-3 (VDE 0660-600-1/-3)
- Degree of protection with door : IP40 with door
- Degree of protection with open door or without door : IP30 (surface). IP2XC (flush)
- Air clearance and creepage distances according to VDE 0110, part 1 and 2/1.89
- Rated insulation voltage: AC 400 V
- Overvoltage category III
- Pollution degree 3
- Insulation class I
- Suitable for use in hollow walls

4. The FW2 board product range

4.1 Delivery form

The FW2 board is available in two delivery forms:

Complete (flush and surface versions): Order number consists of cabinet, internal fittings and door (+ door frame by flush).



FW524F

FW636WT

As individual parts (flush versions): First, the cabinet is ordered without a frame or door. Then the customer must order the frame and door separately. This is particularly useful if the cabinet is to be installed on site at a much earlier stage.

Example:



FW524FB



FW524FD

4.2 Coding

The FW2 Distribution board enclosure ordering number code consists of three components:

- The enclosure type: **FW324WT** (FW+ 3 digits = FW2 board class I)
- The enclosure dimensions 3 digits (height and width): **FW324...** (first digit = Height in number of rows, second and third digits = Width in number of modules)
- The enclosure version: **FW324WT** (W = Wall-mounting, F= Flush-mounting, T= with PEN Terminals)

For example, the reference number **FW636FT** means, that the board is a FW2 board class I with 6-rows and 36 module width, flush-mount and with PEN terminal supplied.

The 7 different enclosure versions are summarized in the table below:

Product code ending	Flush- / Wall-mounted	Internal fitting	With terminals	Clamp type	With flush frame and door	Door type	Door handle
F	Flush	Distributor kit	no		yes	plain	FZ598
FB	Flush	Distributor kit	no		no	plain	-
FBT	Flush	Distributor kit	yes	N + PE terminals	no	plain	-
FD	Flush	Frame and door only	-		Yes (Frame and door only)	plain	FZ598
FT	Flush	Distributor kit	yes	N + PE terminals	yes	plain	FZ598
W	Wall	Distributor kit	no			plain	FZ598
WT	Wall	Distributor kit	yes	N + PE terminals		plain	FZ598

The 12 different enclosure sizes are listed in the “Overview of enclosure product codes” on next page.

4.3 Overview of enclosure product codes

Size 3	Board width		
Flush	334 mm	550 mm	766 mm
Board height 620 mm	FW312F	FW324F	-
	FW312FB	FW324FB	-
	FW312FBT	FW324FBT	-
	FW312FD	FW324FD	-
	FW312FT	FW324FT	-
Surface	330 mm	545 mm	760 mm
height 641 mm	FW312W	FW324W	-
	FW312WT	FW324WT	-

Size 4	Board width		
Flush	334 mm	550 mm	766 mm
Board height 770 mm	FW412F	FW424F	FW436F
	FW412FB	FW424FB	FW436FB
	FW412FBT	FW424FBT	FW436FBT
	FW412FD	FW424FD	FW436FD
	FW412FT	FW424FT	FW436FT
Surface	355 mm	571 mm	787 mm
height 791 mm	FW412W	FW424W	FW436W
	FW412WT	FW424WT	FW436WT

Size 5	Board width		
Flush	334 mm	550 mm	766 mm
Board height 920 mm	FW512F	FW524F	FW536F
	FW512FB	FW524FB	FW536FB
	FW512FBT	FW524FBT	FW536FBT
	FW512FD	FW524FD	FW536FD
	FW512FT	FW524FT	FW536FT
Surface	355 mm	571 mm	787 mm
height 941 mm	FW512W	FW524W	FW536W
	FW512WT	FW524WT	FW536WT

Size 6	Board width		
Flush	334 mm	550 mm	766 mm
Board height 1070 mm	FW612F	FW624F	FW636F
	FW612FB	FW624FB	FW636FB
	FW612FBT	FW624FBT	FW636FBT
	FW612FD	FW624FD	FW636FD
	FW612FT	FW624FT	FW636FT
Surface	355 mm	571 mm	787 mm
height 1091 mm	FW612W	FW624W	FW636W
	FW612WT	FW624WT	FW636WT

Size 7	Board width		
Flush	334 mm	550 mm	766 mm
Board height 1220 mm	-	-	FW736F
	-	-	FW736FB
	-	-	FW736FBT
	-	FW724FD	FW736FD
	-	-	FW736FT
Surface	355 mm	571 mm	787 mm
height 1241 mm	-	-	FW736W
	-	-	FW736WT

5. Enclosures in detail

5.1. FWxxxF

Product code
FW312F
FW324F
FW412F
FW424F
FW436F
FW512F
FW524F
FW536F
FW612F
FW624F
FW636F
FW736F



Example: FW424F

<p>Internal fittings</p> <p>Distributor field:</p> <ul style="list-style-type: none"> - Cover slots for 12, 24 or 36 modules - Distance between DIN rails 150 mm
<p>Without PEN terminals</p>
<p>With frame and door:</p> <p>Door: Plain</p> <p>Steel</p> <p>Door handle 90SL (FZ598)</p>
<p>Included in the scope of delivery:</p> <ul style="list-style-type: none"> - FW2 installation manual Flush

5.2. FWxxxFB

Product code
FW312FB
FW324FB
FW412FB
FW424FB
FW436FB
FW512FB
FW524FB
FW536FB
FW612FB
FW624FB
FW636FB
FW736FB



Example: FW524FB

<p>Internal fittings</p> <p>Distributor field:</p> <ul style="list-style-type: none"> - Cover slots for 12, 24 or 36 modules - Distance between DIN rails 150 mm
<p>Without PEN terminals</p>
<p>Without frame and door</p>
<p>Included in the scope of delivery:</p> <ul style="list-style-type: none"> - FW2 installation manual Flush

5.3. FWxxxFBT

Product code
FW312FBT
FW324FBT
FW412FBT
FW424FBT
FW436FBT
FW512FBT
FW524FBT
FW536FBT
FW612FBT
FW624FBT
FW636FBT
FW736FBT



Example: FW524FBT

<p>Internal fittings</p> <p>Distributor field:</p> <ul style="list-style-type: none"> - Cover slots for 12, 24 or 36 modules - Distance between DIN rails 150 mm
<p>With PEN brass terminals:</p> <ul style="list-style-type: none"> - Size 312, 412: 1x KM13N + 1x KM13E - Size 512, 612: 1x KM13N + 1x KM17E - Size 324: 1x KM17N + 1x KM17E - Size 424, 524, 624: 1x KM25N + 1x KM25E - Size 436: 1x KM13N + 1x KM25N / 1x KM13E + 1x KM25E - Size 536, 636, 736: 1x KM17N + 1x KM25N / 1x KM17E + 1x KM25E
<p>Without frame and door</p>
<p>Included in the scope of delivery:</p> <ul style="list-style-type: none"> - FW2 installation manual Flush - Steel bar with cable strain relief and PEN terminal fixing functions

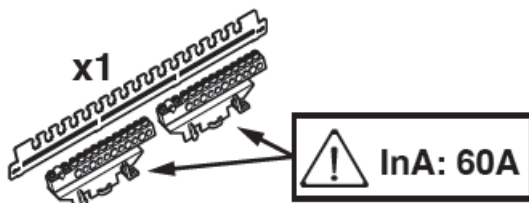

5.4. FWxxxFT

FW312FT
FW324FT
FW412FT
FW424FT
FW436FT
FW512FT
FW524FT
FW536FT
FW612FT
FW624FT
FW636FT
FW736FT



Example: FW536FT

<p>Internal fittings</p> <p>Distributor field:</p> <ul style="list-style-type: none"> - Cover slots for 12, 24 or 36 modules - Distance between DIN rails 150 mm <p>With PEN brass terminals:</p> <ul style="list-style-type: none"> - Size 312, 412: 1x KM13N + 1x KM13E - Size 512, 612: 1x KM13N + 1x KM17E - Size 324: 1x KM17N + 1x KM17E - Size 424, 524, 624: 1x KM25N + 1x KM25E - Size 436: 1x KM13N + 1x KM25N / 1x KM13E + 1x KM25E - Size 536, 636, 736: 1x KM17N + 1x KM25N / 1x KM17E + 1x KM25E <p>With frame and door:</p> <p>Door: Plain Steel Door handle 90SL (FZ598)</p> <p>Included in the scope of delivery:</p> <ul style="list-style-type: none"> - FW2 installation manual Flush - Steel bar with cable strain relief and PEN terminal fixing functions

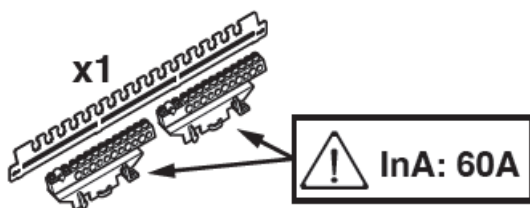

5.5. FWxxxW

FW312W
FW324W
FW412W
FW424W
FW436W
FW512W
FW524W
FW536W
FW612W
FW624W
FW636W
FW736W



Example: FW612W

<p>Internal fittings</p> <p>Distributor field:</p> <ul style="list-style-type: none"> - Cover slots for 12, 24 or 36 modules - Distance between DIN rails 150 mm
<p>Without PEN terminals</p>
<p>With door:</p> <ul style="list-style-type: none"> - Plain - Steel - Door handle 90SL (FZ598)
<p>Included in the scope of delivery:</p> <ul style="list-style-type: none"> - FW2 installation manual Surface

5.6. FWxxxWT

FW312WT
FW324WT
FW412WT
FW424WT
FW436WT
FW512WT
FW524WT
FW536WT
FW612WT
FW624WT
FW636WT
FW736WT



Example: FW624WT

<p>Internal fittings</p> <p>Distributor field:</p> <ul style="list-style-type: none"> - Cover slots for 12, 24 or 36 modules - Distance between DIN rails 150 mm <p>With PEN brass terminals:</p> <ul style="list-style-type: none"> - Size 312, 412: 1x KM13N + 1x KM13E - Size 512, 612: 1x KM13N + 1x KM17E - Size 324: 1x KM17N + 1x KM17E - Size 424, 524, 624: 1x KM25N + 1x KM25E - Size 436: 1x KM13N + 1x KM25N / 1x KM13E + 1x KM25E - Size 536, 636, 736: 1x KM17N + 1x KM25N / 1x KM17E + 1x KM25E <p>With door:</p> <ul style="list-style-type: none"> - Plain - Steel - Door handle 90SL (FZ598) <p>Included in the scope of delivery:</p> <ul style="list-style-type: none"> - FW2 installation manual Surface - Steel bar with cable strain relief and PEN terminal fixing functions
--

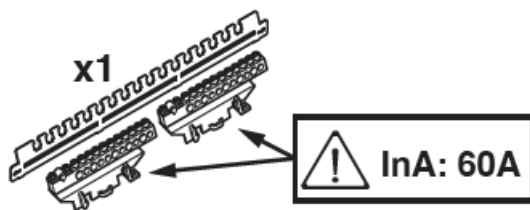

6. Frames and doors in detail

6.1. Features

FW2 doors are similar to the FZxxx doors in the Univers range, but are 10mm longer and have different widths. Doors are compatible with FW2 flush- and surface mount boards.

For all enclosure sizes, a single door can be mounted and closed with a 1-point latch with handle. Door opening angle is 110°.

Front flush, the door can be closed from the right or from the left and can be removed without tools and is equipped with door handle FZ598 (from the old 90SL series) and can be sealed (see chapter 4.5.4.2)

The frame depth is only 13mm (wall overhang). Frames with pre-assembled door can be ordered with part number FZxxxF

6.2. Door distance to interior fittings

Flush-mounted enclosures:

The minimum distance from the DIN rail to the door is 75mm and from the cover to the door 27mm (without frame depth adjustment). Considering the flush frame depth adjustment on the wall due to plaster thickness, these dimensions will increase accordingly. This must be taken into account when mounting modular equipment.

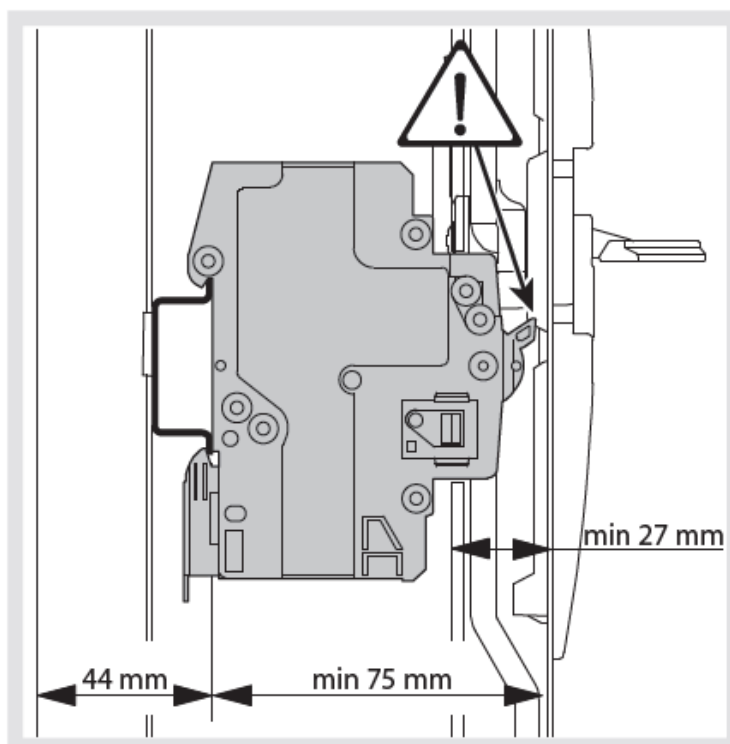

Wall-mounted enclosures:

The standard distance from the DIN rail to the door is 75mm and from the cover to the door 27mm. This must be taken into account when mounting modular equipment.

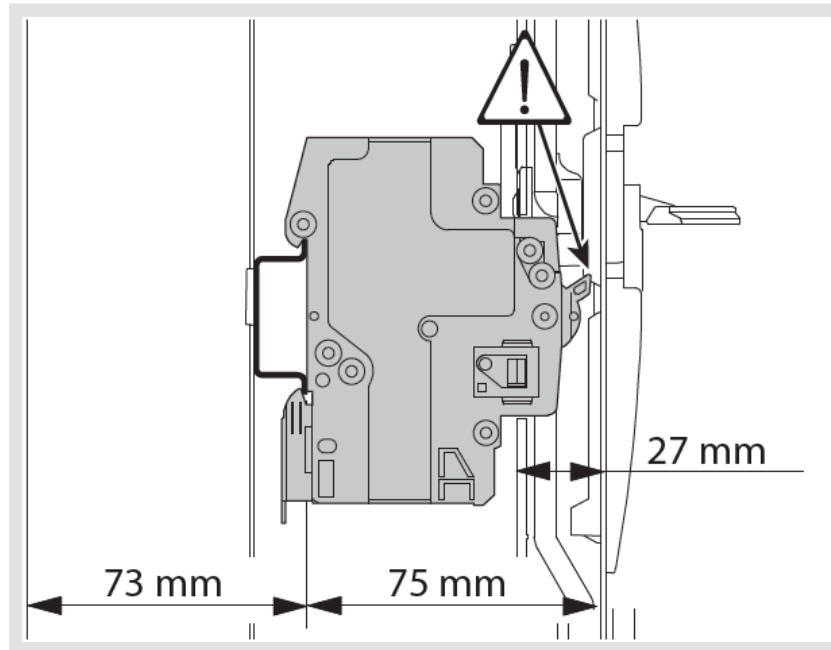

The distance from the DIN rail to the door can be increased by 28mm by removing the 4 spacers. See chapter 2.1 Internal fittings.

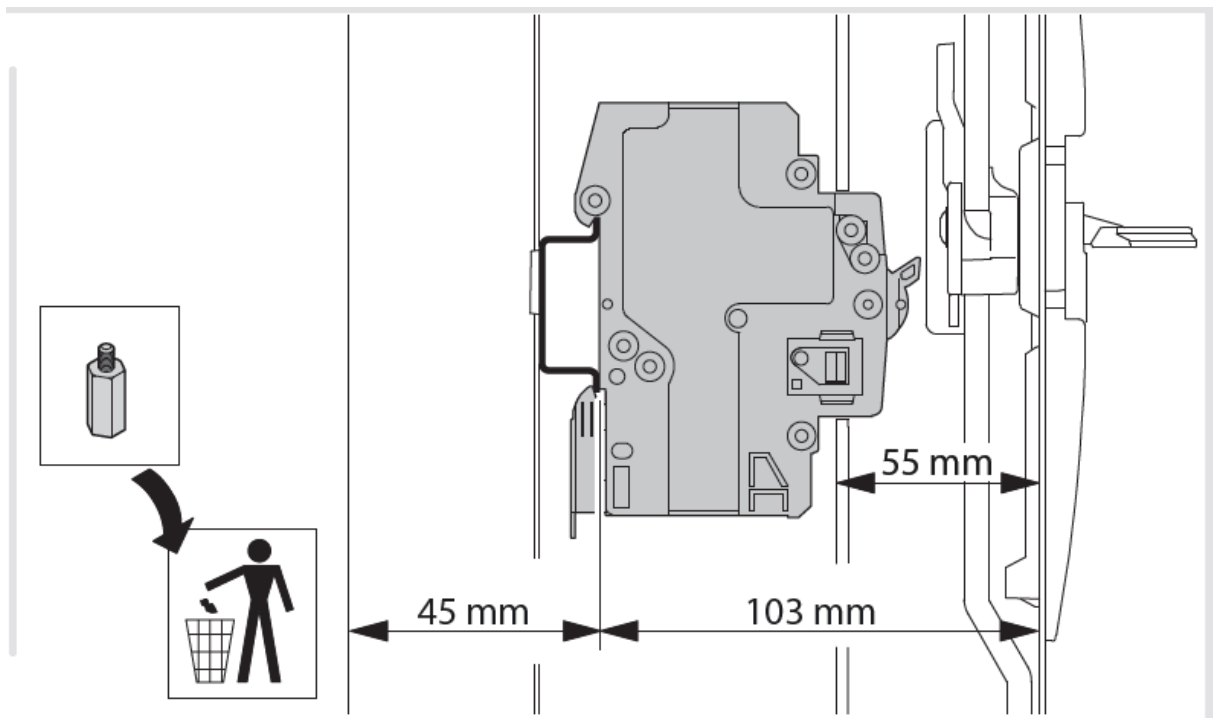

6.3. FWxxxFD

Frames with doors for the flush enclosures are available by ordering the number code FWxxxFD.

Product code
FW312FD
FW324FD
FW412FD
FW424FD
FW436FD
FW512FD
FW524FD
FW536FD
FW612FD
FW624FD
FW636FD
FW736FD



Example: FW524FD

Frame and Door only:

Door: Plain

Steel

Door handle 90SL (FZ598)

6.4. Doors as spare parts

Doors can be ordered as spare parts under following 77... numbers:

Board size	Surface / Flush Door product code
FW312xx	770956800
FW324xx	770951900
FW412xx	770956900
FW424xx	770957200
FW436xx	770957400
FW512xx	770957000
FW524xx	770942600
FW536xx	770957500
FW612xx	770957100
FW624xx	770957300
FW636xx	770943900
FW736xx	770957600

6.5. Door accessories

6.5.1. Door handle as spare part

The standard door handle (90SL) is available as a spare part with product code FZ598. A sealing wire with a maximum diameter of 2mm can be inserted into the right hole (H) if the door needs to be sealed.

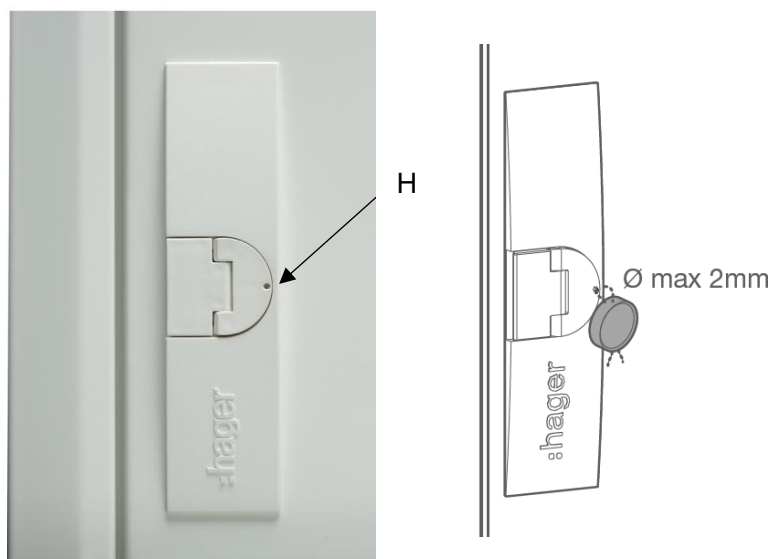

mounted door handle FZ598

Sealing with wire

6.5.2. Drawing map

The **FZ794** A4 transparent drawing card is self-adhesive and can be stuck on the inside of the door.



Drawing map FZ794

7. Enclosure features and accessories

7.1. Internal fittings

Fitting structure

- Symmetrical, rotatable by 180°
- Composed of 2 vertical metal uprights with screwed DIN rails each 150 mm
- DIN rails are 35 mm wide and 15 mm high



Internal fittings from FW312xx boards (flush and surface)

Dismounting: The internal fittings can be dismounted by unscrewing the four 10 mm hexagonal nuts at the corners.

Depth-adjustment: For the surface enclosures, it is also possible to mount the internal fittings 28 mm deeper by removing the four 13 mm hexagonal metallic spacers under the nuts.

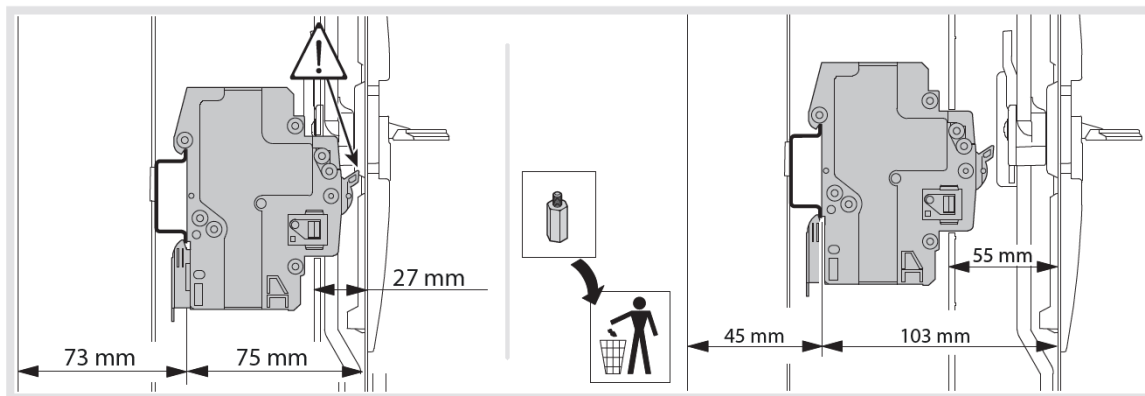

By doing this, the distance from the DIN rails to the door can be increased from 75 mm to 103 mm and the distance from covers to door from 27 to 55 mm. There is a lower risk that the door collides with a roomy modular device, if there is no possibility for placing the device elsewhere.

7.2. Accessories for internal fittings

7.2.1. DIN rails

Additional DIN rails in 12, 24 and 36 module widths can be mounted on the internal fittings. These DIN rails are 7.5mm high, 35 mm wide and 284, 500 or 716 mm long. They are supplied with two M4 screws. They can be mounted as an additional DIN rail at the top or bottom of the internal fittings (see black arrows below), for example as a fixing rail for modular terminals.

Board width	DIN rail Product code
FWx12xx	FZ12D
FWx24xx	FZ24D
FWx36xx	FZ36D



DIN rail 12 modules **FZ12D** 7,5x35x284mm



Mounting possibilities for the 12 modules FZ12D (black arrows)



Mounting of the 24 modules DIN rail FZ24D in the board FW424FT

7.2.2. Covers and cover accessories

Covers: The 12, 24 and 36 module wide 1-row metal covers can be ordered as a set of 2. They are available through the following internal product codes. Covers are always supplied with 2 screws. The top and bottom covers are wider than the center covers because they also cover the terminal and cable entry areas. They are 225 mm high (see covers A, C, E below). Middle covers are 150 mm high (see covers B, D, F below).

Code	Reference	Description
A	770944500	Cover, FW2, 12 modules, 1-row, h:225mm
B	770944600	Cover, FW2, 12 modules, 1-row, h:150mm
C	770943300	Cover, FW2, 24 modules, 1-row, h:225mm
D	770943400	Cover, FW2, 24 modules, 1-row, h:150mm
E	770944700	Cover, FW2, 36 modules, 1-row, h:225mm
F	770944800	Cover, FW2, 36 modules, 1-row, h:150mm



Cover strips: Once the modular devices are installed, the remaining cover slots can be closed with the **S35S** (12 modules wide, 219 mm) or **S35V** (1000 mm wide) cover strips, which can be cut to the remaining width to be closed.

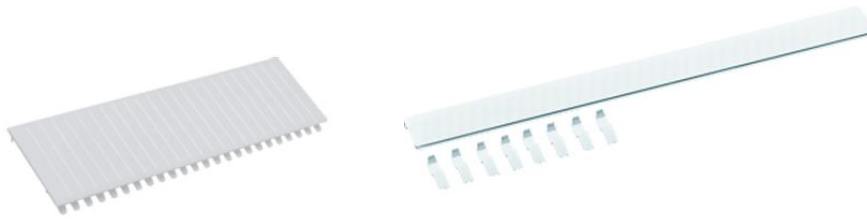

S35S (219 mm)

S35V (1000 mm)

Marking strips: The kit **UZ08Z1** contains 5 self-adhesive marking strips of 1 m length. Those strips have been developed for the Univers range, but can also be used for the FW2 range. They can be applied directly to the metal cover surface. They are made of transparent plastic with double-sided adhesive tape and include a paper strip that can be removed and re-inserted into the transparent profile for marking or printing.



Kit UZ08Z1

7.3. Earthing protection

The earthing of the door can be made by connecting an earthing cable at door side. Top and bottom metallic covers are pre-perforated left- and right-hand side for passing an earthing cable through them.

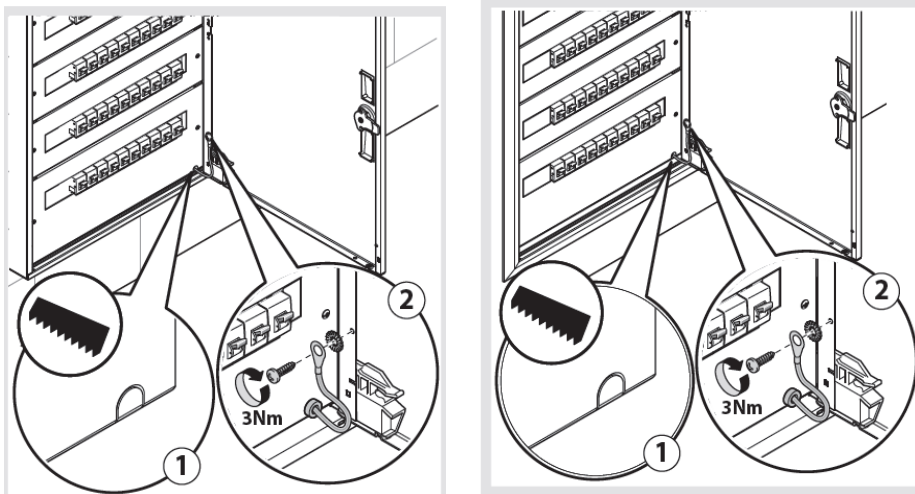

The earthing cable has to be connected on the other side with the with internal fittings

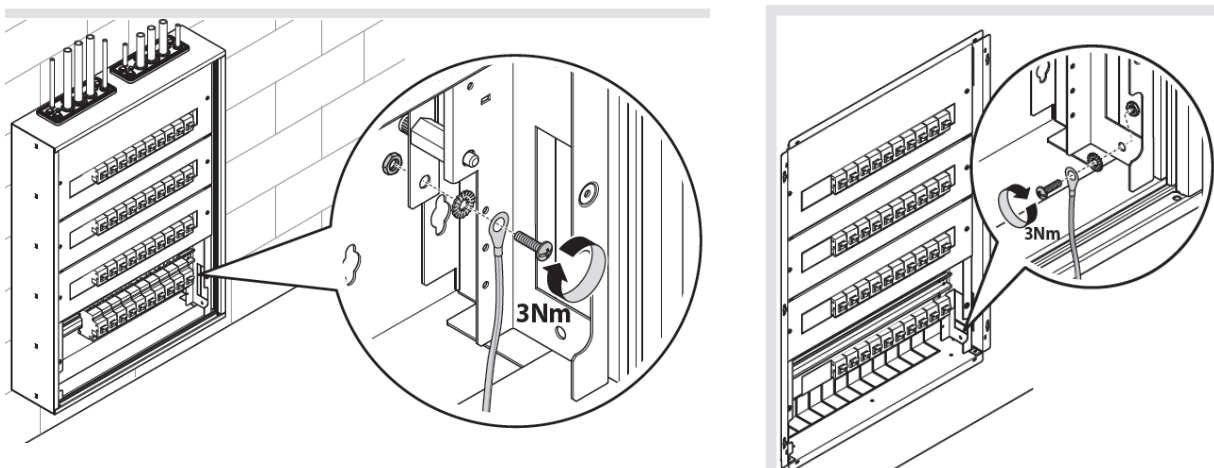

A yellow Class I sticker is sticked on the internal fittings to indicate that it should be connected to the earth.

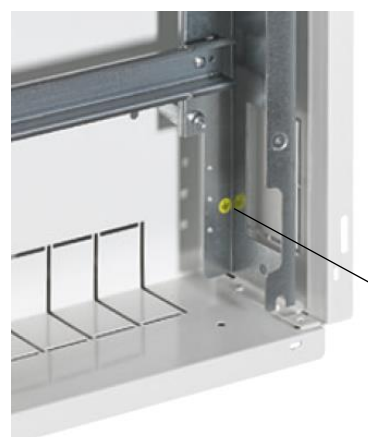

7.4. Cable entries

7.4.1. Cable entries top/bottom

Flush boards

Pre-punched cut-outs are located on the top and bottom areas of the flush board. The openings are the same size on the top/bottom and rear, making it easier to insert the board over the incoming cables (see photo below). The pre-punched areas are repeated every 36 mm (24 mod.) or 43 mm (12 and 36 mod.) and can be removed individually or all together (see next page). Each metal plate removed provides a 46 x 36 mm (12 and 24 mod.) or 46 x 43 mm (36 mod.) cable entry area.

In total, the maximum opening area top/bottom with all cut-outs removed is 219 x 46 mm (12 mod.), 435 x 46 mm (24 mod.) or 651 x 46 mm (36 mod.).

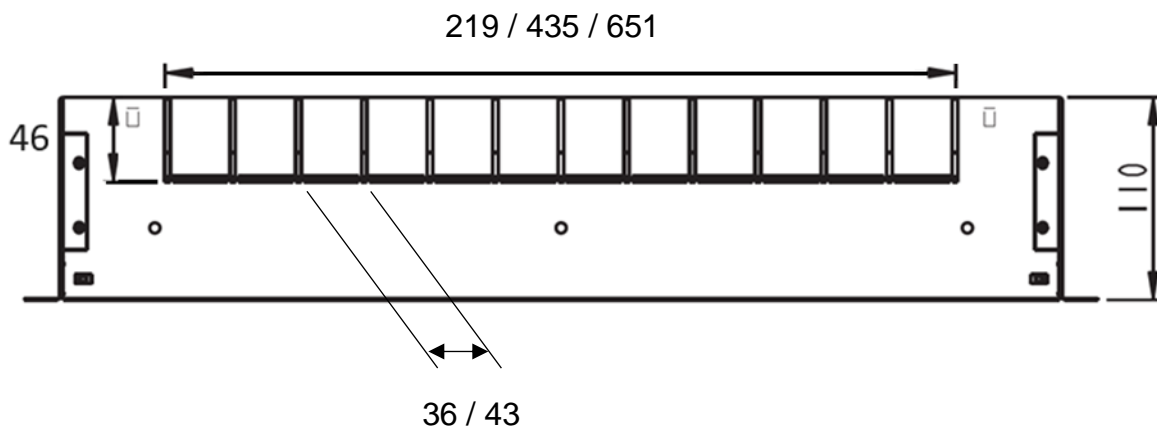

The cable entries also extend to the rear and are the same size as at the top/bottom cable entries.



As the cable entry plates and the housing are metallic, it is highly recommended that the metal edges be protected with an edge strip or tape to prevent damage to incoming cables.

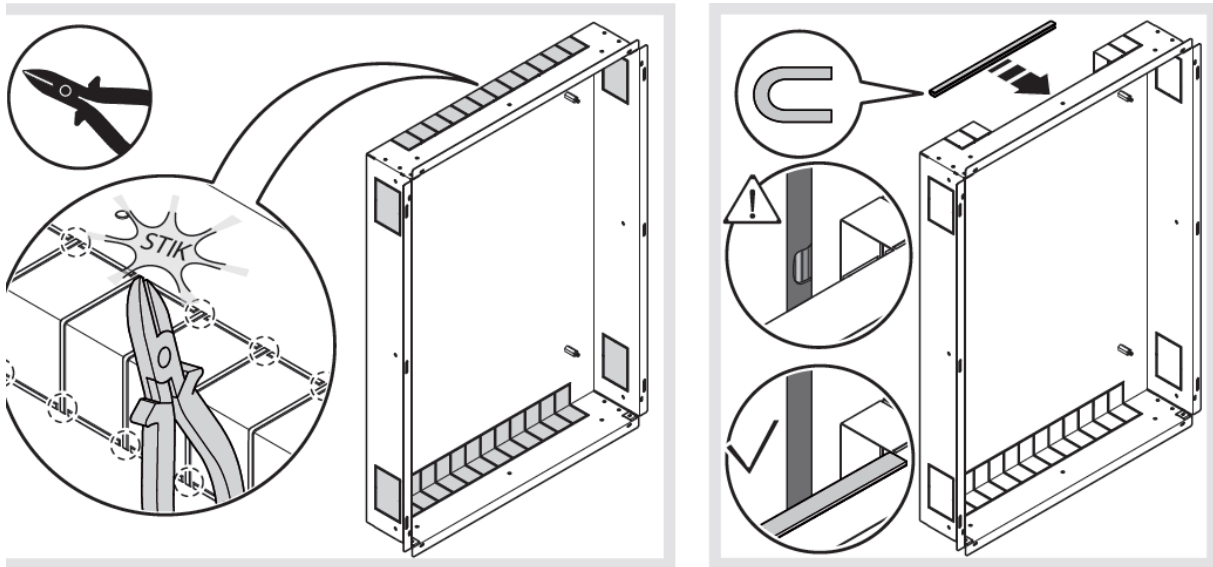

Surface boards

The surface mount enclosures (W, WT) are equipped with flanges on top side. Depending on the desired cabling, it may be necessary to rotate the enclosure prior to wall mounting. Because the internal fittings and covers are symmetrical, the board can be mounted with the required cable entry openings located at the top or bottom by rotating the board 180 degrees.

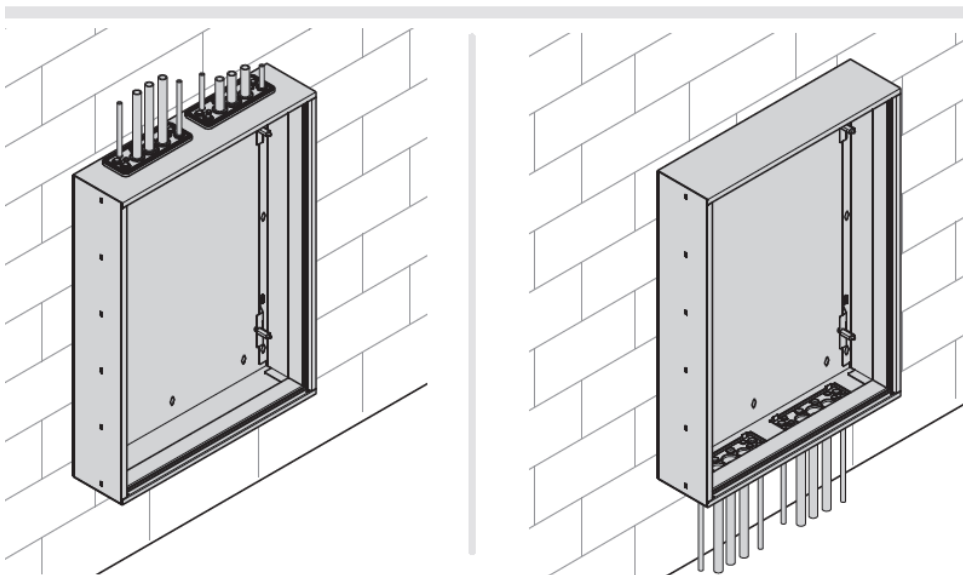

Flanges are made of smooth PE-LD plastic material and can be easily cut with a knife. Pipe diameters from the flange are listed below:

- 1x Ø13-36 mm
- 2x Ø6-29 mm
- 4x Ø10-16 mm
- 2x Ø9-20 mm
- 4x Ø6-10 mm

The flange can be completely cut out along the inner groove (red line), so that an opening of 186x57 mm can be obtained. The remaining small plastic wall protects the incoming cables from damage such as contact with the metal edges.

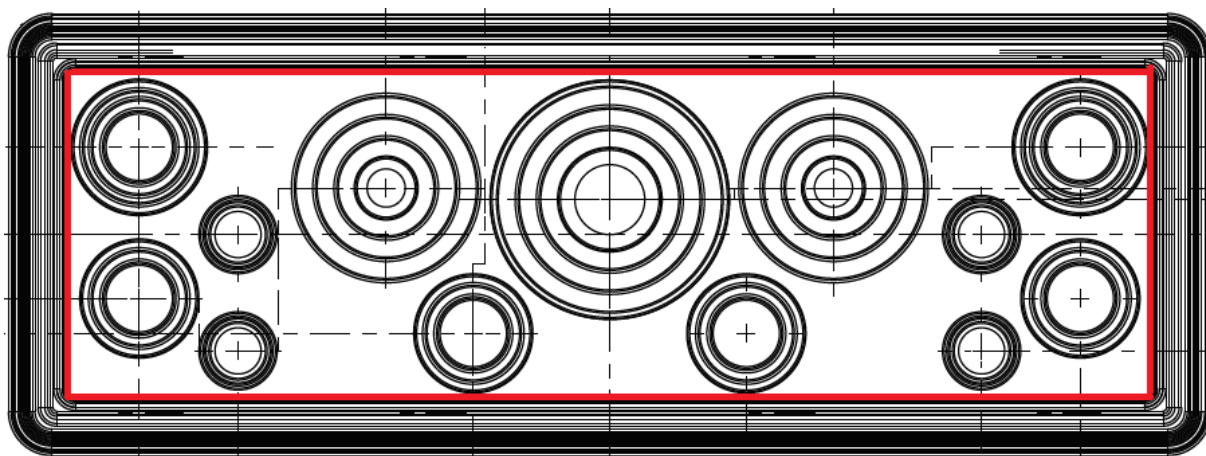

Sketch drawing from cable entry flange



Top view from FW312WT enclosure with cable entry flange

7.4.2. Side cable entries

Flush boards

FW2 flush boards include two pre-punched metal plates on the side for cutting out, resulting in a cable entry area of 90 x 60 mm for each opening.



Side cable entries in flush board

As for top/bottom cable entries, it is also highly recommended that the metal edges be protected with an edge strip or tape to prevent damage to incoming cables.

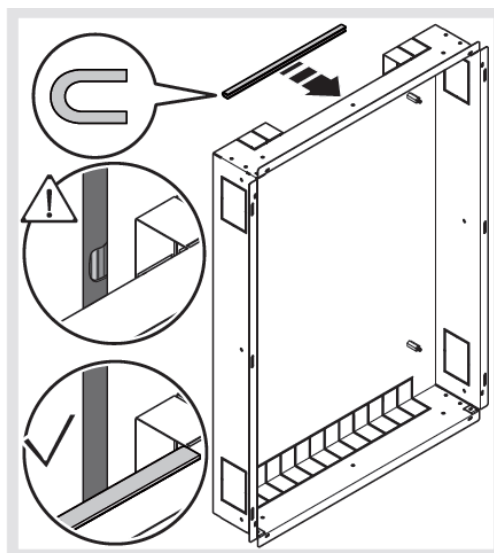

7.5. Cable strain relief

Enclosure product codes ending with T such as FWxxxFT, FWxxxWT (T stands for **T**erminals) are delivered with 1 continuous metal rail for mounting the PEN clamps. The bar can be screwed to the top or bottom of the internal fittings. Several hooks are punched along the bar for fixing cables and pipes with cable ties.

These bars are also available under product codes **FZ12H** (width 12), **FZ24H** (width 24) und **FZ36H** (width 36), especially for board product codes not ending in T or when a second bar is needed on the other side.

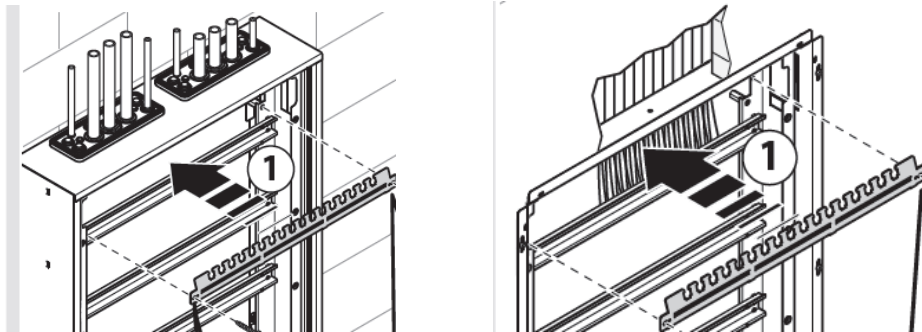

Mounting of the cable strain relief bar



Strain relief bar FZ12H



Strain relief bar FZ24H



Strain relief bar FZ36H

7.6. PEN terminals

The FZ12H, FZ24H and FZ36H strain relief bars with brass terminals from the Univers product range are supplied with each FW2 board code with a T ending. Terminals can be ordered separately using the product codes **KMxxE** (PE, green) or **KMxxN** (N, blue). The two-digit xx indicates the maximum number of connections possible in the brass profile. KM13N can connect up to 13 cables, see cable diameters at bottom of page.



FW436FT board with terminals delivered-by in a cardboard packaging

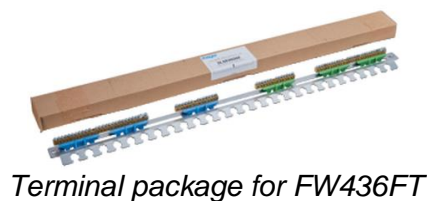

Terminal package for FW436FT



FW436FT board with mounted terminals

The terminal configuration in each board size is summarized in the following table:

Product code	Terminal configuration
FW312WT	1x KM13N + 1x KM13E
FW412WT	
FW312FT	
FW412FT	
FW512WT	1x KM13N + 1x KM17E
FW612WT	
FW512FT	
FW612FT	
FW324WT	1x KM17N + 1x KM17E
FW324FT	
FW424WT	1x KM25N + 1x KM25E
FW524WT	
FW624WT	
FW424FT	
FW524FT	
FW624FT	
FW436WT	1x KM13N + 1x KM25N
FW436FT	1x KM13E + 1x KM25E
FW536WT	1x KM17N + 1x KM25N 1x KM17E + 1x KM25E
FW636WT	
FW736WT	
FW536FT	
FW636FT	
FW736FT	



KM13N



KM17E



KM25E

Terminal size	Quantity x Section mm ²
KM13x	6x16 ² +7x10 ²
KM17x	1x25 ² +8x16 ² +8x10 ²
KM25x	1x25 ² +4x16 ² +20x10 ²

8. Inspection and maintenance

Important for safe operation

Regular preventative maintenance is important for the safe operation of switchgear and controlgear assemblies.

Checks and maintenance only by electrically skilled person with appropriate testing experience

Tests and maintenance must be carried out by electrically skilled persons who have experience in testing switchgear and controlgear assemblies.

8.1. Testing intervals for recurring tests

In the interest of ensuring a high level of operational safety, the commercial switchgear and controlgear assembly should be tested at least every 4 years by an electrically skilled person to check that it is in perfect working order (recommendation of the German Social Accident Insurance regulation 3 (DGUV) (formerly BGV A3)). National or insurer regulations may extend or shorten the test interval. Shortened intervals may be defined to ensure proper functionality and safe operation due to:

- the demands on the operating equipment,
- external influences,
- changes to the operating parameters and ambient conditions,
- special kinds of compartments and systems according to DIN VDE 100 group 700,
- in the event of complicated operating conditions, special circumstances, such as shocks and exposure to moisture,
- the specifications of the device or operating equipment manufacturer set forth in their instructions,
- according to applicable national standards and regulations.

Hager recommends performing a test at least once a year:

- a visual inspection (external inspection),
- switching operations of individual protective devices and switching devices (operation of RCD test buttons every six months),
- document all tests, for example, in an inspection book.

Recommended recurring tests

System / operating equipment	Test interval	Type of test	Inspector
Electrical systems and stationary operating equipment	4 years	For perfect working order	Electrically skilled person (with testing experience)
Electrical systems and stationary operating equipment in operating sites, special kinds of spaces and systems according to DIN VDE 100 group 700	1 year	For perfect working order	Electrically skilled person (with testing experience)
Enclosure, jacketing and protective devices	1 year recommendation	External visual inspection Switching operation / functional testing	Electrically skilled person (with testing experience)
RCD (earth-leakage circuit breaker)	Every six months	Operate test switch	Ordinary person

8.2 Minimum inspection/maintenance measures

The minimum maintenance conditions for switchgear and controlgear assemblies with FW2 distribution enclosures are listed below (compliance based on VDE 0100, part 610 for switchgear assemblies):

The recurring tests during commissioning, in the event of changes, after faults or at suitable intervals include:

- Inspections
- Measurements
- Testing
- Documenting test results
- Eliminating the identified defects, for example, by replacing the faulty operating equipment or devices
- Documenting the performed work and changes

Tests through inspection

In the inspection, the electrically skilled person checks the electrical switchgear for perfect working order, including its operating equipment and devices. The inspection includes both the equipment exterior/environment and the internal fittings.

- Check the protection against the direct and indirect contact of active parts
- Check the basic protection and the basic insulation, the earthing protection
- Check the additional insulation for fault protection
- Check all necessary covers for personal protection
- Check for signs of ageing
- Check for mechanical, chemical, electrical and thermal stress

External inspections, tests	Test values, comments, remedy
Test the ambient conditions	<ul style="list-style-type: none"> - Effectiveness of the ventilation system and heating of operating space - Room temperature, relative humidity, aggressive air components, dust
Accessibility, minimum distances	Escape routes, clearances
Visual inspection of covers and jacketings	Damage that adversely affect the type of protection, such as: <ul style="list-style-type: none"> - Missing parts - Locking of doors - Paintwork damage
Condition of jacketing, attachment, cover	If necessary, improve or replace housing parts, clean soiling, and fix the fastenings, observing the installation manuals in doing so
Check for corrosion traces	<ul style="list-style-type: none"> - Repair damage with a suitable FZ791N touch-up stick. For more significant damage, grind, clean (e.g. with white spirit, spot-removing spirit or universal thinner) and then paint - Check the operating conditions and ambient conditions
Ventilation/traces of a rise in temperature	Ensure clearance in front of ventilation inserts, take suitable measures
Hinge pin lock	Lock, replace missing hinge pins
Check that the door hinges can be moved easily	If necessary, spray anhydrous lubricant that protects against corrosion
If necessary, check that the lock and locking parts can be moved easily	Spray dry lubricant on moving locking parts and replace seals if necessary
Seals, flange, contact hazard protection covers	Replace if damaged
Check according to protection class and protection type	Protection class I on FW2 boards and internal system. Check the earthing connection of frame, door and board
Type label/markings of the switchgear and controlgear assembly for legibility	If necessary, clean and ensure legibility
Documentation for completeness/legibility	Ensure completeness and legibility

8.3 Cleaning

For operational safety reasons, soiling must be removed. Dirt deposits can cause overheating. During cleaning, observe at least the following safety points:

External cleaning (outside of door and frame)

External cleaning (when door is not open) by ordinary persons is permitted on distribution boards that may be operated by ordinary persons (DBO) according to EN 61439-3.

- Clean the outside of the door and frame with a dry, lint-free cloth
- Do not use scouring agents
- Do not use liquids, do not carry out wet cleaning

The inside may only be cleaned by electrically skilled persons

- Cleaning inside the switchgear and controlgear assembly may only be carried out by electrically skilled persons after the system has been disconnected from the power supply
- Cleaning must only be performed by vacuuming (vacuum cleaner) and with dry cloths (dry cleaning with a vacuum cleaner). During cleaning work, an electrostatic charge in the jet nozzle may result in direct or indirect hazards to personnel
- Do not use compressed air for cleaning
- No wet cleaning
- Remove all dirt
- Hager offers a cleaning agent for plastic surfaces under order number **VZ404**

9. Decommissioning, disassembly and disposal

9.1. Decommissioning

Decommissioning only by electrically skilled persons

- Switch off the system
- Observe the residual energies, residual voltages and residual heat
- Disconnect the system and supply lines from all poles and on all sides
- Secure against reconnection
- Ensure that no voltage is present
- Disconnect the supply line / incoming unit
- Securely lock the system

9.2. Disassembly and disposal

Disassembly only by electrically skilled persons

- Check the disconnection and absence of voltage
- Disassemble the system in reverse order of the assembly and installation procedure

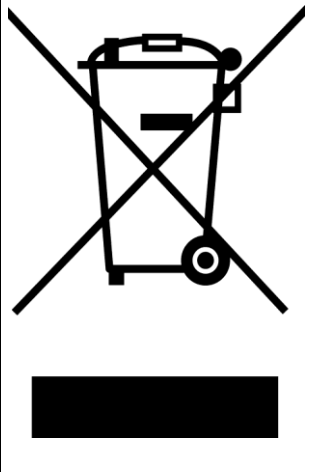
	<p>Devices marked with this symbol are subject to European directive 2012/19/EU for WEEE (Waste Electrical and Electronic Equipment). Electrical and electronic equipment may not be disposed of in domestic waste.</p> <p>Dispose of them according to the local applicable regulations.</p> <p>Separate the available raw materials of the system by disposal type and material:</p> <p>Parts containing copper, such as busbars and lines</p> <p>Electrical scrap: Terminals, short circuit devices</p> <p>Metal scrap: Jacketing, mounting plates</p>
--	---

10. List of all product codes

Product code	Page	Product code	Page	Product code	Page	Product code	Page
770942600	27	FW424F	18	FW612FT	21	S35S	33
770943300	32	FW424FB	19	FW612W	22	S35V	33
770943400	32	FW424FBT	20	FW612WT	23	UZ08Z1	33
770943900	27	FW424FD	26	FW624F	18	VZ404	44
770944500	32	FW424FT	21	FW624FB	19		
770944600	32	FW424W	22	FW624FBT	20		
770944700	32	FW424WT	23	FW624FD	26		
770944800	32	FW436F	18	FW624FT	21		
770951900	27	FW436FB	19	FW624W	22		
770956800	27	FW436FBT	20	FW624WT	23		
770956900	27	FW436FD	26	FW636F	18		
770957000	27	FW436FT	21	FW636FB	19		
770957100	27	FW436W	22	FW636FBT	20		
770957200	27	FW436WT	23	FW636FD	26		
770957300	27	FW512F	18	FW636FT	21		
770957400	27	FW512FB	19	FW636W	22		
770957500	27	FW512FBT	20	FW636WT	23		
770957600	27	FW512FD	26	FW736F	18		
FW312F	18	FW512FT	21	FW736FB	19		
FW312FB	19	FW512W	22	FW736FBT	20		
FW312FBT	20	FW512WT	23	FW736FD	26		
FW312FD	26	FW524F	18	FW736FT	21		
FW312FT	21	FW524FB	19	FW736W	22		
FW312W	22	FW524FBT	20	FW736WT	23		
FW312WT	23	FW524FD	26	FZ12D	31		
FW324F	18	FW524FT	21	FZ12H	39		
FW324FB	19	FW524W	22	FZ24D	31		
FW324FBT	20	FW524WT	23	FZ24H	39		
FW324FD	26	FW536F	18	FZ36D	31		
FW324FT	21	FW536FB	19	FZ36H	39		
FW324W	22	FW536FBT	20	FZ598	28		
FW324WT	23	FW536FD	26	FZ791N	43		
FW412F	18	FW536FT	21	FZ794	28		
FW412FB	19	FW536W	22	KM13E	40		
FW412FBT	20	FW536WT	23	KM13N	40		
FW412FD	26	FW612F	18	KM17E	40		
FW412FT	21	FW612FB	19	KM17N	40		
FW412W	22	FW612FBT	20	KM25E	40		
FW412WT	23	FW612FD	26	KM25N	40		

11. Glossary

EN 61439 / IEC 61439 / VDE 0660-600

The EN (IEC) 61439 series of standards aims to harmonise the rules and requirements for switchgear and controlgear assemblies.

The valid part of the EN (IEC) 61439 standard series is always the applicable part of the standard, e.g. Part 2 of the (EN (IEC) 61439-2)

standard for power

switchgear and controlgear assemblies, together with the basic Part 1 of the standard (EN (IEC) 61439-1).

Connection between European standard and International standard

European standard	International standard	German standard	Classification VDE specifications
EN (IEC) 61439 (all parts)	IEC 61439 (all parts)	DIN EN (IEC) 61439 (VDE 0660-600) (all parts)	VDE 0660-600 (all parts)

Parts of EN (IEC) 61439 standard

Part of European standard	Content
EN (IEC) 61439-1	Low-voltage switchgear and controlgear assemblies – Part 1: General rules
EN (IEC) 61439-2	Low-voltage switchgear and controlgear assemblies – Part 2: Power switchgear and controlgear assemblies (PSC)
EN (IEC) 61439-3	Low-voltage switching controlgear assemblies - Part 3: Distribution boards intended to be operated by ordinary persons
EN (IEC) 61439-4	Low-voltage switchgear and controlgear assemblies – Part 4: Particular requirements for assemblies for construction sites (ACS)
EN (IEC) 61439-5	Low-voltage switchgear and controlgear assemblies – Part 5: Assemblies for power distribution in public networks
EN (IEC) 61439-6	Low-voltage switchgear and controlgear assemblies – Part 6: Busbar trunking systems (busways)
EN (IEC) 61439-7	Low-voltage switchgear and controlgear assemblies - Part 7: Assemblies for specific applications such as marinas, camping sites, market squares, electrical vehicles charging stations

Supplements for parts of the EN 61439 standard

Part of European standard	Content
EN 61439-1 Supplement 1	General rules: Guidance to specifying switchgear and controlgear assemblies
EN 61439-1 Supplement 2	General rules: A method of temperature-rise verification of low-voltage switchgear and controlgear assemblies by calculation
EN 61439-2 Supplement 1	Power switchgear and controlgear assemblies: Guide for testing under conditions of arcing due to internal fault

Distribution boards for operation by ordinary people (DBO) according to EN 61439-3

DBO: According to EN 61439-3, a DBO is a distribution boards for operating by ordinary persons (Distribution Board intended to be operated by ordinary persons). This is a switchgear and controlgear assembly for distributing electrical energy for applications in residential areas and other locations where operation is intended by ordinary persons.

The distribution boards are manufactured and tested for operation by ordinary persons (DBO) according to EN 61439 Part 1 and Part 3. Part 3 of the standard 61439 defines the specific requirements for distribution boards for operation by ordinary persons (DBO).

A switchgear and controlgear assembly that allows operation by ordinary persons must include a type plate that specifies the standard EN 61439-3 (VDE 0660-600-3) as the applied standard.

Characteristic features of such a switchgear and controlgear assembly:

1. They are intended for operation by ordinary persons, including switching operations and changing fuse inserts. They are applications in residential areas or similar household applications in a functional building
2. The outgoing circuits contain short circuit devices that are intended for operation by ordinary persons; in line with e.g. IEC 60898-1 (miniature circuit breakers/MCBs), IEC 61008 (residual current operated circuit breakers, RCCBs), IEC 61009 (residual current circuit breakers with overcurrent protection, RCBOs), IEC 62423 (type B RCCBs and RCBOs) and IEC 60269-3 (D fuse inserts for use by ordinary persons). Additional information is provided in Section 8 of EN (IEC) 614393.
3. Their rated voltage against earth does not exceed 300 V AC.
4. The rated current (I_{nc}) of the outgoing circuit is 125 A maximum; the rated current of the switchgear and controlgear assembly (I_{nA}) is 250 A maximum.
5. The switchgear and controlgear assembly is intended for distributing electrical energy and may also include the appropriate controlling and signaling devices.
6. The switchgear and controlgear assembly is closed and fixed/stationary.
7. The switchgear and controlgear assembly may be intended for indoor or outdoor installation (for the FW2 field distributor: indoor installation).

- The protection type of a DBO for indoor installation must be at least IP2XC.

- Devices or replacement components intended for operation by ordinary persons: Protection against contact with live parts must be in place when operating devices or replacing components.

- The IK code against mechanical influence must correspond to at least IK05 for indoor installation.

- Operating conditions: Degree of pollution 2 applies as a minimum.

- The number of neutral conductor connections must be at least the number of outgoing connections on outgoing circuits that require a neutral conductor connection.

- The DBO must have at least two connections for protective equipotential bonding conductors to the electrical system.

- Switchgear and controlgear assemblies to EN (IEC) 614393 that permit operation by ordinary persons may also include equipment that ordinary persons are not allowed to operate. Effective measures must be in place to prevent ordinary persons from operating this

equipment.

Additional information is provided in EN (IEC) 61439 Part 1 and 3.

IP Protection type / IP degree of protection

The protection type indicates the suitability of electrical equipment, and therefore also of switchgear and controlgear assemblies, for use in different environmental conditions. For each switchgear and controlgear assembly, the protection type is specified with the IP code according to IEC 60529 and verified according to EN (IEC) 61439.

- Verification of protection against ingress of foreign bodies and against contact with live parts.
- Verification with regard to preventing water from entering the system.

The protection type IP code enables the selection of suitable equipment to prevent the risk of electric shock. It applies to jacketings, covers and housings. It is specified using two code numbers and an optional, additional letter.

- The first code number (0-6) indicates protection against solid foreign objects from entering the system and protection against contact with dangerous parts.
- The second code number (0-8) indicates protection against water from entering the system.
- The additional letter (A-D) indicates protection against contact with dangerous parts.

Degree of pollution

The degree of pollution defines the ambient conditions of a switching device. If the switching device is installed in a housing, the ambient conditions within the housing apply. The degree of pollution according to EN (IEC) 61439 refers to the ambient conditions that are intended for the switchgear and controlgear assembly. The four defined degrees of pollution are used to assess the clearances and creepage distances in the micro environment.

- The degree of pollution 3 is defined as conductive pollution or dry, non-conductive pollution, which is expected to become conductive due to condensation.
- The degree of pollution 2 is defined only as non-conductive pollution in which, however, temporary conductivity can be expected due to condensation.

12. Index

A

About this manual • 3
Accessories • 28-40

C

Cable entries • 35-38
Cable strain relief • 39

Cleaning • 44

Coding • 15

Covers • 32

D

DBO: Distribution boards intended to be operated by ordinary persons according to EN (IEC) 61439-3 • 48

Decommissioning, disassembly and disposal • 45

Delivery form • 14

Dimensions • 9, 10, 24, 25, 30

DIN rails • 31

Drawing map • 28

Door accessories • 28

Door handle • 28

Door product codes • 27

E

EN (IEC) 61439 • 47

Enclosures in detail • 18-23

Earthing protection • 34

F

Features • 8, 24, 29-40

Fittings • 29, 30

Flange • 36, 37

Flushmount enclosures • 18-21

Frames and doors • 24-27

FWxxxF • 18

FWxxxFB • 19

FWxxxFBT • 20

FWxxxFD • 26

FWxxxFT • 21

FWxxxW • 22

FWxxxWT • 23

G

Glossary • 47

I

Index • 50

Inspection and maintenance • 41-43

IP protection type/IP degree of protection • 49

M

Marking strips • 33

P

Product codes • 16, 17, 46

Pollution degree • 49

Power loss • 12, 13

Product range • 14-17

R

Requirements for authorized personnel • 7

S

Safety • 5-7

Sealing • 28

Spare parts • 27, 28, 32, 39, 40

T

Technical data • 8

Terminals (PEN) • 40

U

Used symbols and trademarks • 4

W

Warranty and Liability • 3

Wallmount enclosures • 22, 23



Hager Electro GmbH und Co. KG

Zum Gunterstal
66440 BLIESKASTEL
GERMANY
Tel.: +49 6842 945 0
Fax: +49 6842 945 4625
E-Mail: info@hager.de
www.hager.de

Hager Support

Hager Vertriebsgesellschaft mbH & Co. KG

Zum Gunterstal
66440 BLIESKASTEL
GERMANY
Tel.: +49 6842 945-4460
Fax: +49 6842 945-4445
E-Mail: svb@hager.de