

Operating and assembly instructions

KNX building management system

KNX push-button module

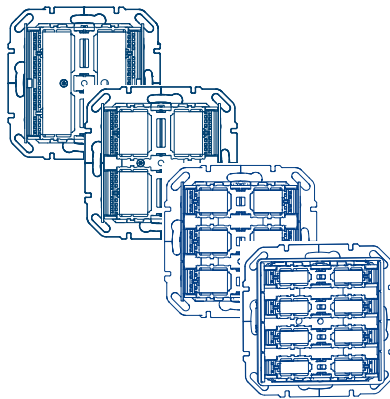

Push-button technical unit, x-gang, KNX Secure
WAK1011, WAK1014, WAK1016, WAK1018



Table of contents

1	Introduction.....	3
2	Safety instructions.....	5
3	Scope of delivery.....	6
4	Design and layout of the device.....	8
5	Function.....	9
6	Operation.....	12
7	Information for qualified electricians.....	13
7.1	Installation and electrical connection.....	13
8	Commissioning.....	15
9	Dismantling.....	18
10	Appendix.....	19
10.1	Technical data.....	19
10.2	Troubleshooting.....	19
10.3	Accessories.....	19
10.4	Disposal note.....	21

1 Introduction

These instructions describe the safe and correct installation and commissioning of the KNX Secure push buttons. These instructions are provided as information in addition to the product.

Symbols used

- Single-step instruction or any sequence.
- ① Multi-step instruction. Sequence must be observed.
- List
- ▶ Reference to additional documents/information















	Scope of delivery		Installation by a qualified electrician		For further information on configuring the device, refer to the application manual
	KNX-certified		Supports KNX Data Secure		
	Compatibility with KNX S-mode (ETS)		Compatibility with Hager Easytool		
	Suitable for use throughout Europe and Switzerland		Directive 2012/19/EU on waste electrical and electronic equipment		

Table 1: Symbols used

Symbol	Warning word	Consequence of non-observance
	Danger	Leads to serious injuries or death.
	Warning	Can lead to serious injuries or death.
	Caution	Can lead to minor injuries.
	Caution	Can lead to device damage.
	Note	Can lead to physical damage.

Symbol	Description
	Warning against electric shock.
	Warning against damage from mechanical stress.
	Warning against damage from electricity.
	Warning against damage from fire.

Introduction



Electronic devices may only be assembled, installed and configured by a specialist with electrical training and certification in accordance with the relevant installation standards of the country. The accident prevention regulations valid in the appropriate countries must be complied with.

In addition, these instructions are intended for system administrators and electrically trained specialists.

2 Safety instructions

Electrical devices must only be installed and assembled by a qualified electrician in accordance with the relevant installation standards, guidelines, regulations, directives, safety and accident prevention directives of the country.

Failure to comply with these installation instructions may result in damage to the device, fire or other hazards.

When installing and routing cables, always comply with the applicable regulations and standards for SELV electrical circuits.

During renovation work, protect the device from contamination from paint, wallpaper paste, dust, etc. The device could get damaged.

3 Scope of delivery

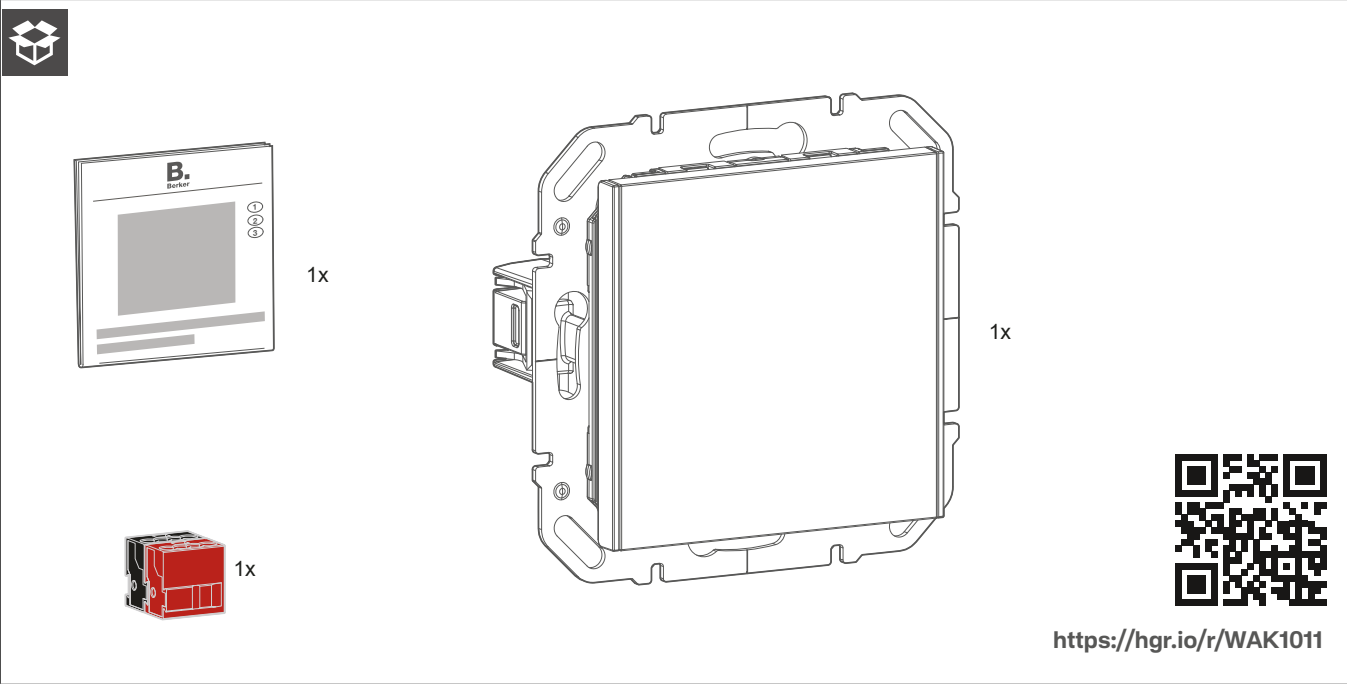

Fig. 1: Scope of delivery WAK1011

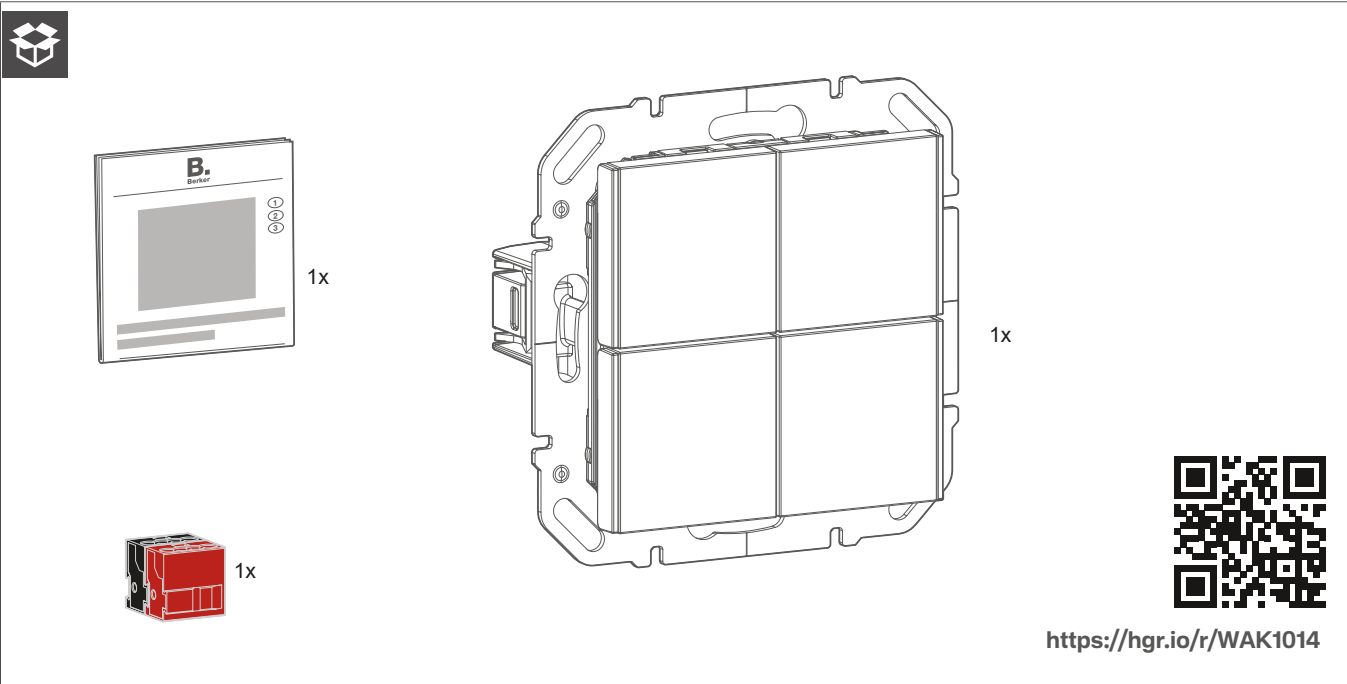

Fig. 2: Scope of delivery WAK1014

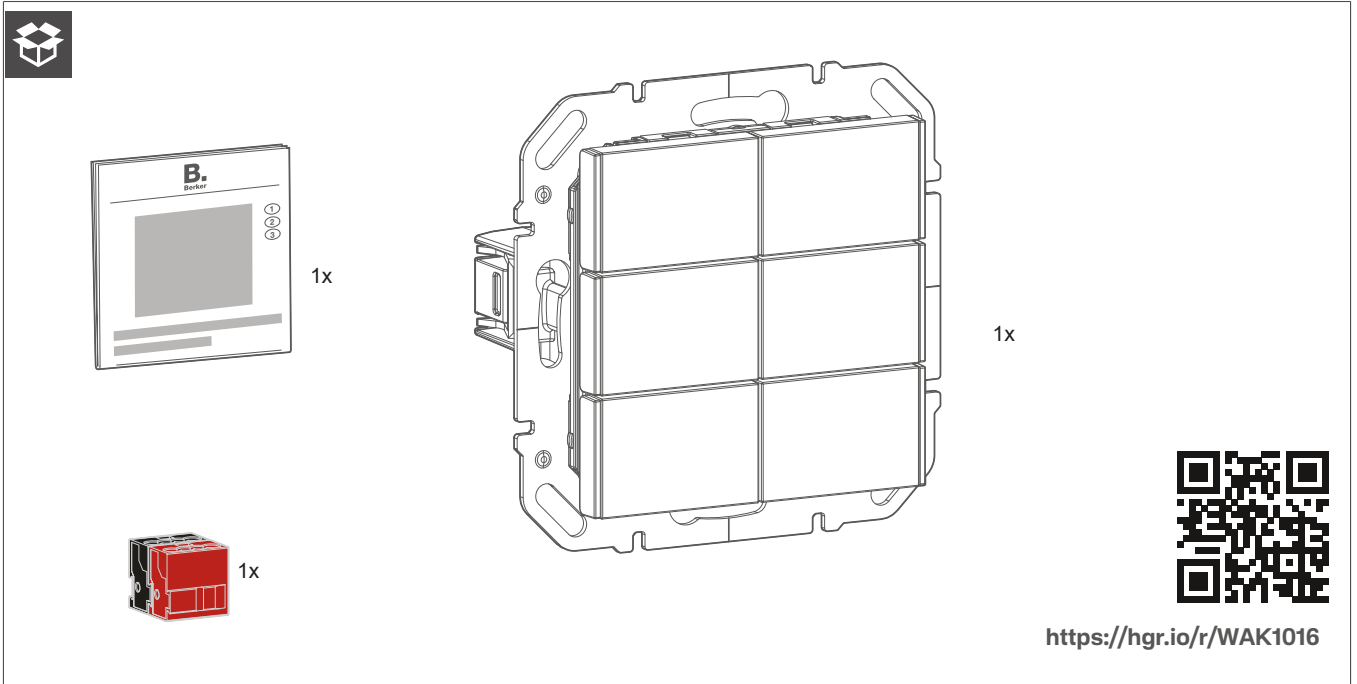

Fig. 3: Scope of delivery WAK1016

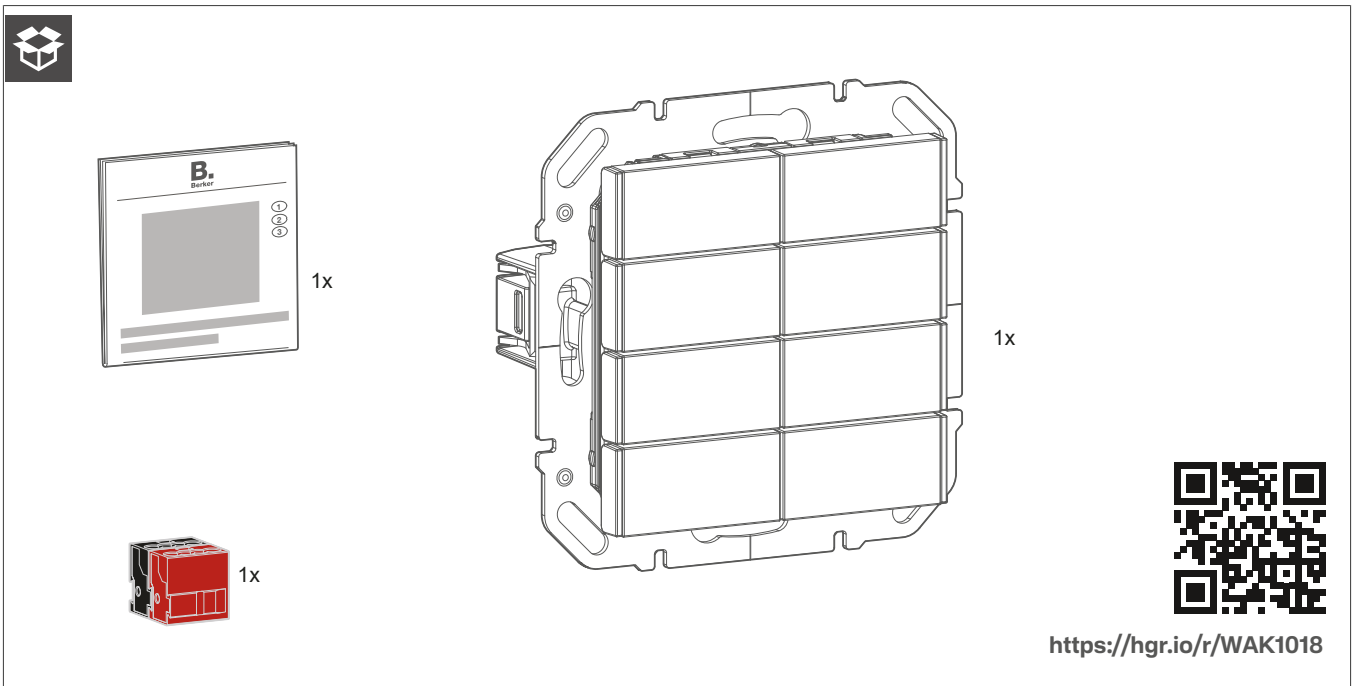

Fig. 4: Scope of delivery WAK1018

4 Design and layout of the device

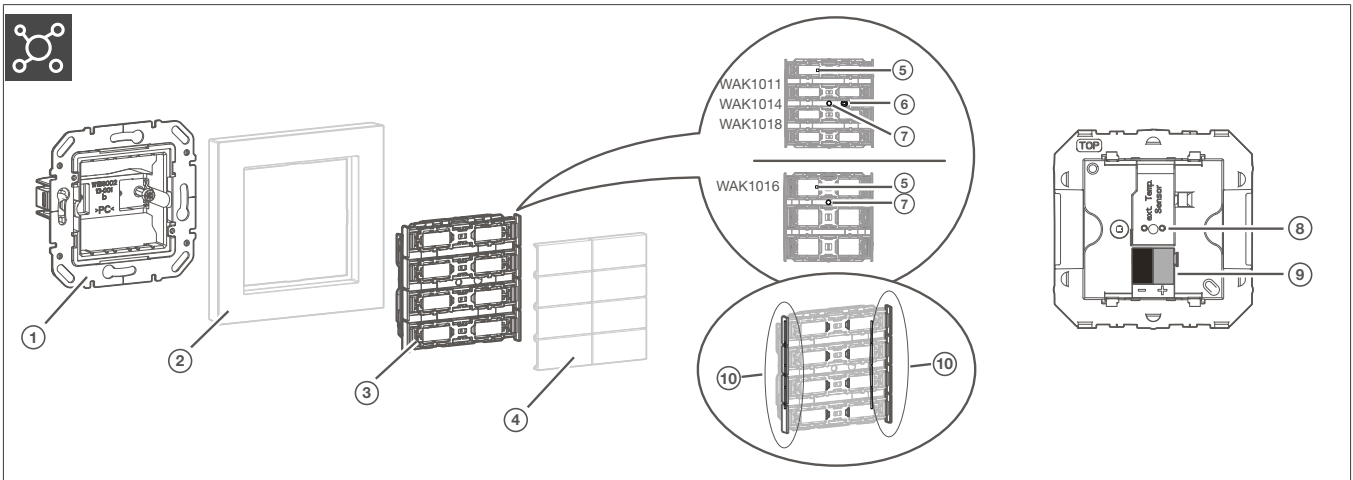

Fig. 5: Design and layout of the device

- ① Supporting ring with fastening claws
- ② Frame (not in scope of delivery)
- ③ KNX Secure push button insert (depending on design)
- ④ Cover for push button insert (not in scope of delivery)
- ⑤ Programming LED
- ⑥ Drill hole for dismantling protection screw (depending on design)
- ⑦ Programming button
- ⑧ Plug-in interface for temperature sensor EK090
- ⑨ KNX bus connection terminal
- ⑩ Status LED of the button

5 Function

System information

This device is a product of the KNX system and corresponds to the KNX guidelines. Detailed specialised knowledge obtained from KNX training courses is required for understanding.

The device is KNX Data Secure-compatible. KNX Data Secure can be configured in the ETS project and offers protection against manipulation in building automation. Detailed knowledge on this subject is required. A device certificate (FDSK), which is attached to the device (QR code sticker), is required for commissioning a KNX Secure device. During installation, the device certificate must be removed from the device and kept in a safe place.

The planning, installation and commissioning of the device are carried out with KNX-certified software.

systemlink commissioning

The function of the device is software-dependent. The software is to be obtained from the product database. You can find the latest version of the product database, technical descriptions as well as conversion and additional support programmes from our website.

easylink commissioning

The function of the device is configuration-dependent. The configuration can also be performed using devices developed specially for simple setting and commissioning.

This type of configuration is only possible with devices compatible with the easylink system. easylink stands for easy, visually supported commissioning. Preconfigured standard functions are assigned to the inputs/outputs by means of a service module.

Functional description

The devices are monoblock modules with an integrated bus coupling unit. The following functions can be assigned to the buttons: Switching/toggling, dimming, shutter/blind, timer, value 1 byte, value 2 bytes, colour control, room thermostat extension unit, priority, scene, 2-channel mode, step switch and automatic control deactivation. The assignment of the individual functions is freely selectable for each button and defined by the setting in the ETS.

The status LEDs integrated in the operation buttons can be used to display the returned status of the triggered function.

Function

Correct use

- Operation of loads, e.g. light on/off, dimming, blind up/down, saving and opening light scenes, etc.
- Installation into wall box according to DIN 49073

Product characteristics

- Commissioning and programming in S-mode and E-mode
- KNX Data Secure-compatible
- Push-button functions: Switching/dimming, shutter/blind, value transmitter, timer, colour control, scene, room thermostat extension unit, priority, 2-channel mode, step switch and automatic control deactivation
- With status LEDs to the left and right of the push buttons
- Function and colour of the status LEDs configurable for the device

WAK1011

WAK1014

WAK1016

WAK1018

1 function buttons

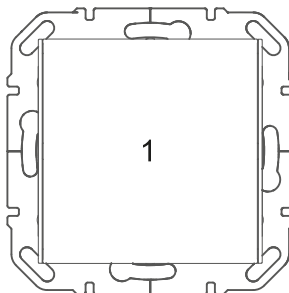

2 function buttons

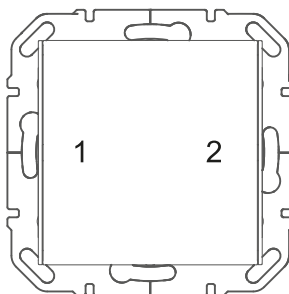

4 buttons

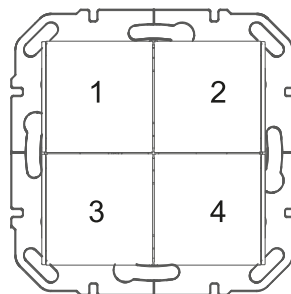

6 buttons

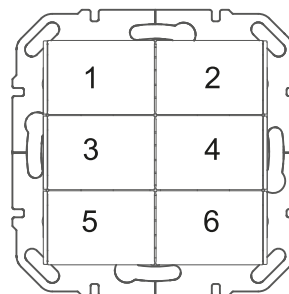

8 buttons

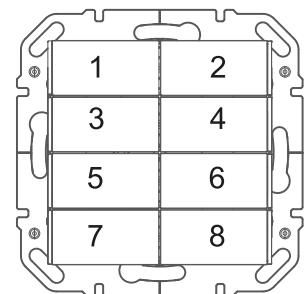

4 function buttons

Table 2: Number and order of buttons per device / Number of function buttons on the device (WAK1011xx)

WAK1011

WAK1014

WAK1016

WAK1018

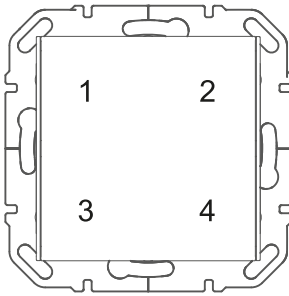

Table 2: Number and order of buttons per device / Number of function buttons on the device (WAK1011xx)

6 Operation

Triggering of functions and operation of electrical loads takes place via push-button operation areas (Fig. 6, dashed) and can be set individually for each device.

Example: Push button 4-gang (WAK1014xx)

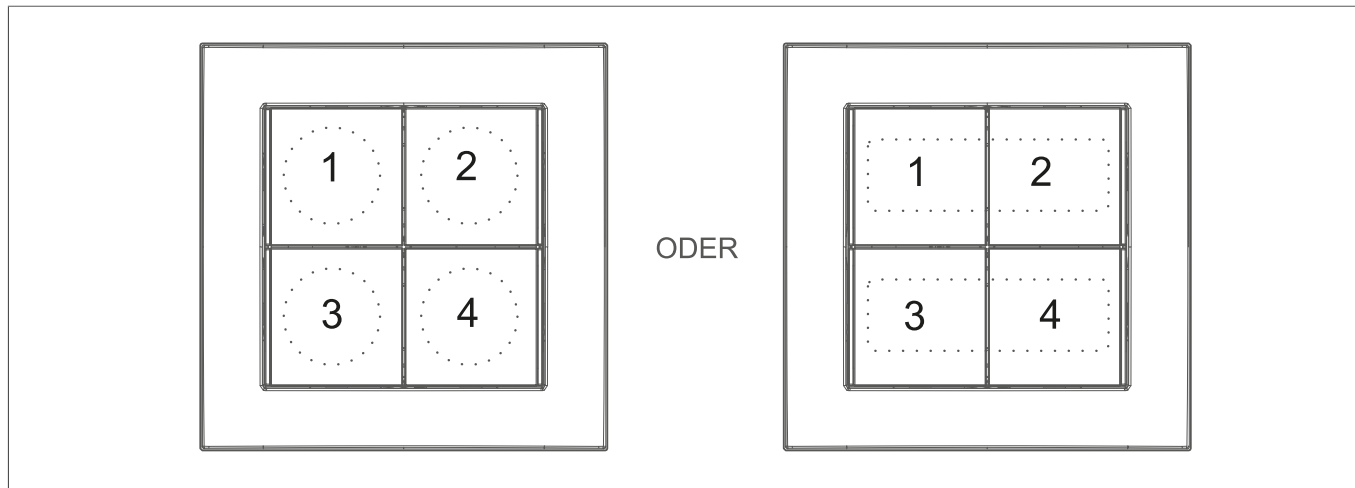

Fig. 6: Push button operation areas

Operation of the single button:

- Switching lighting on/off and dimming brighter/darker is carried out alternately by repeated pressing of a push-button operation area.

Operation as rocker (pair of buttons):

- Two adjacent push-button operation areas form a pair of buttons. For example, touching the left-hand area switches the lighting on/makes it brighter; touching the right-hand area switches it off/makes it darker.

7 Information for qualified electricians

7.1 Installation and electrical connection



Danger

Electric shock when live parts are touched!

An electric shock can lead to death!

- Disconnect all connection cables before working on the device and cover any live parts in the area!

Connection and installation of the device

- Mount the supporting ring in the correct position on a wall box (Fig. 7), note the ‘TOP’ marking.

Connect device without external temperature sensor

- Run the bus cable with the connecting terminal through the frame and connect it to the back of the device. Route the KNX bus connection cable underneath the centre bar (Fig. 7/Fig. 8).

Optional:

Connect device with external temperature sensor

- Also run the connection cable for the external temperature sensor with the connecting terminal through the frame and connect it to the back of the device. Feed the connection cables for the external temperature sensor above the centre bar (Fig. 9/Fig. 10).
- Lay an external temperature sensor (see Chapter 10.3, "Accessories") in ductwork and guide out the sensor head at the measurement point.

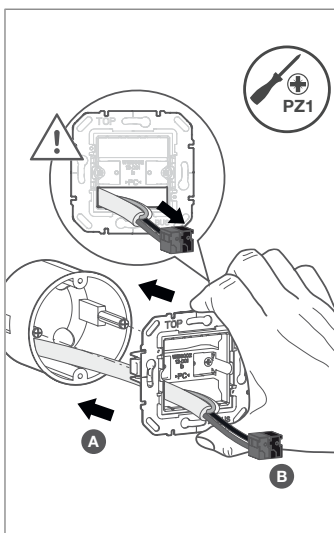

Fig. 7: Fitting the supporting ring

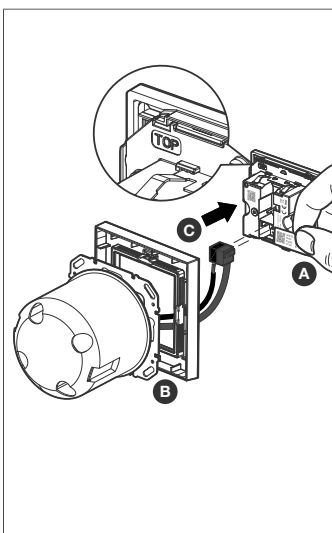

Fig. 8: Connecting the KNX bus connection terminal

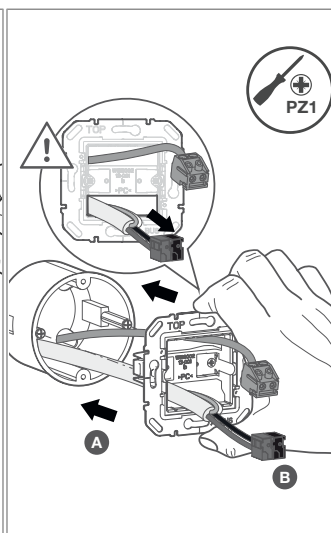

Fig. 9: Optional: Run through cable for ext. temperature sensor

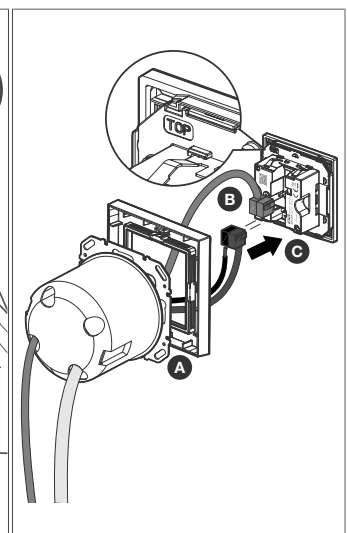

Fig. 10: Optional: Run through cable for ext. temperature sensor

Optional: Apply dismantling protection

- If required, use the screw to establish dismantling protection (Fig. 11).
- Attach the buttons to the push-button module (Fig. 12).



Information

The dismantling protection is only available for WAK1011, WAK1014, WAK1018 devices. Device referenced WAK1016 does not have any dismantling protection.

The dismantling protection screw (WDA9091) should be ordered separately and is not included with the devices ([Accessories](#)).

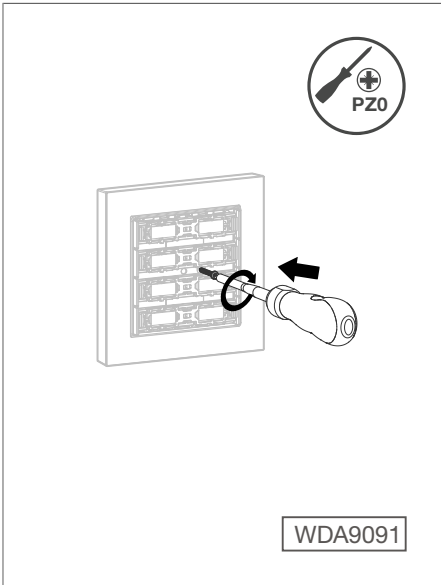

Fig. 11: Establishing dismantling protection

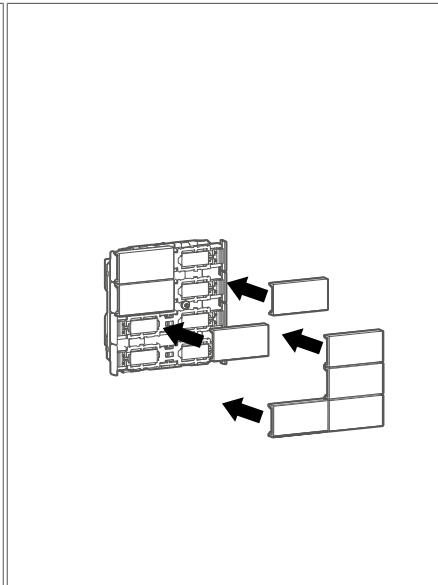

Fig. 12: Attaching the buttons

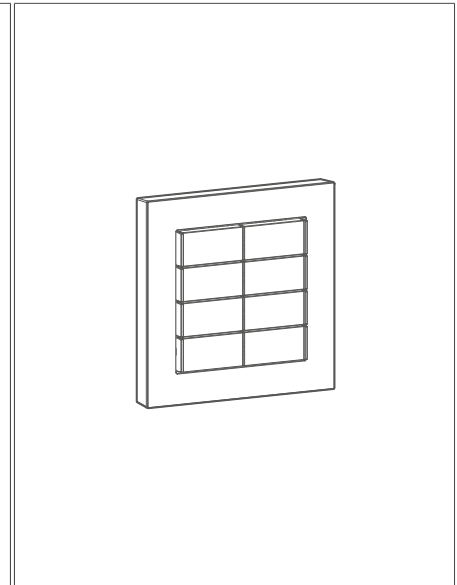

Fig. 13: Fully assembled device

8 Commissioning

The device can be programmed in three ways:

- KNX systemlink mode (standard ETS programming) [see "Commissioning in KNX systemlink mode \(ETS\)", page 15](#)
- KNX Secure mode [see "Commissioning in KNX Secure mode", page 16](#)
- KNX easylink mode [see "Commissioning in KNX easylink mode", page 17](#)

Commissioning in KNX systemlink mode (ETS)

The device is connected and ready for use. The following procedure is usually recommended.

systemlink - Loading the physical address and application software



The physical address can only be assigned to one device. Only one device can be in programming mode.

It is recommended to set the physical address before installation.

- 1 If available, release the buttons using the programming button ([Fig. 5/8: Design and layout of the device](#)).
- 2 Switch on the bus voltage.
- 3 Press the programming button.
The programming LED ([Fig. 5/5: Design and layout of the device](#)) lights up.



If the button does not light up, no bus voltage is present on the device.

- 4 Load the physical address into the device.
The programming LED goes out.
- 5 Load the application software into the device.
- 6 Note down the physical address on the labelling field.



If incompatible application software is loaded, the status LEDs flash to indicate this.

- 7 Reattach the buttons.

Commissioning

Commissioning in KNX Secure mode

- ☑ The device has been installed and connected so that it is ready for operation.
- ① Activate safe commissioning mode in ETS.
- ② Enter the device certificate (QR code) (Fig. 16), scan it (Fig. 15) or add it to the project in ETS.

i

Note!

Use a high-resolution camera to scan the QR code.

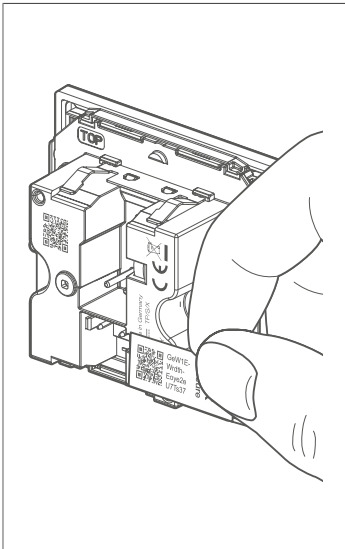

Fig. 14: Removing the device certificate from the device (similar to illustration)

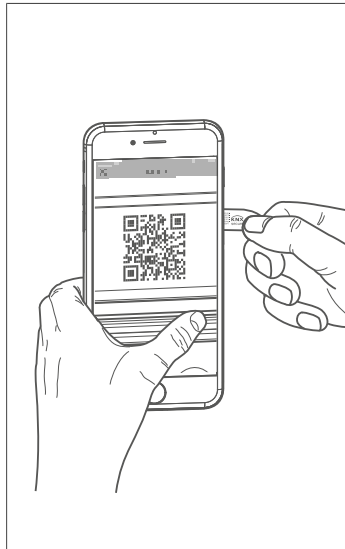

Fig. 15: Scanning the QR code

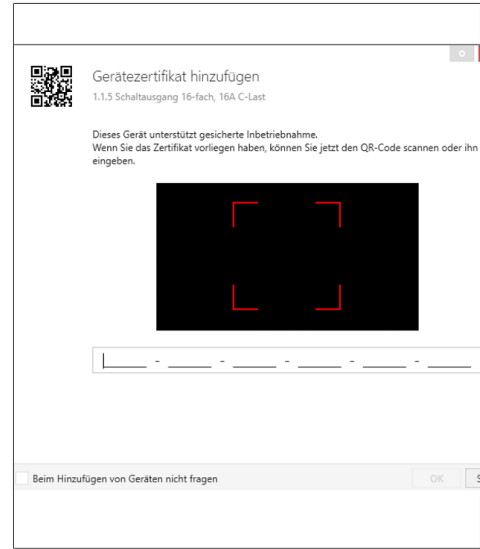

Fig. 16: Entering the QR code manually

- ③ Document all passwords and keep them in a safe place.
- ④ Remove the device certificate (QR code) from the device and store it with the passwords.
- ⑤ Note down the device certificate along with the physical address and item reference in a list.

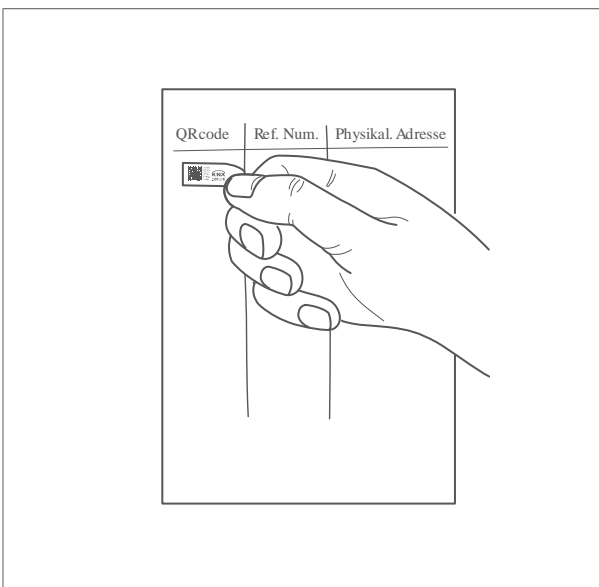

Fig. 17: Storing the device certificate in the project documentation

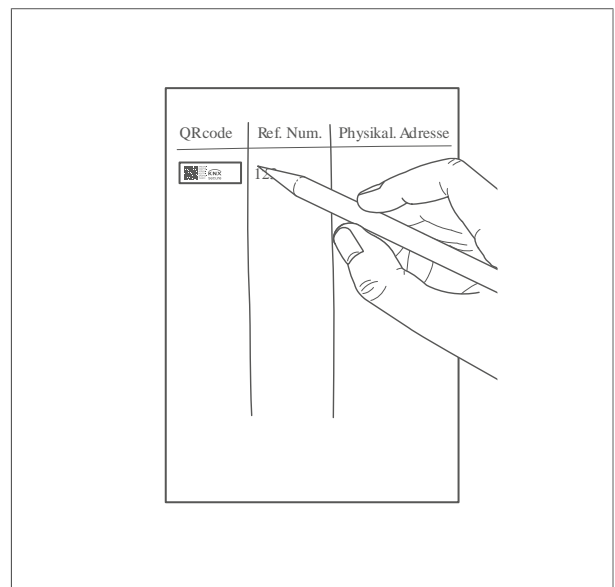

Fig. 18: Noting down the article number and physical address for the device certificate

Commissioning in KNX easylink mode

The function of the device is configuration-dependent. The configuration can also be performed using devices developed specially for simple setting and commissioning.

This type of configuration is only possible with devices compatible with the easylink system. easylink stands for easy, visually supported commissioning. Preconfigured standard functions are assigned to the inputs/outputs by means of a service module.

Commissioning the device

The device has been installed and connected correctly.

- ① Switch on the mains voltage.
- ② Switch on the bus voltage.

Depending on the parameterisation, the status LEDs of the buttons light up.

9 Dismantling

Dismantling the device



Danger

Electric shock when live parts are touched!

An electric shock can lead to death!

- Isolate all connection cables before working on the device and cover any live parts in the area!

- 1 Remove the buttons from the push-button module (see Fig. 19).
- 2 Optional: Undo the dismantling protection screw (see Fig. 20).
- 3 Remove the push-button module from the supporting ring. Hold on to the design frame (see Fig. 21).
- 4 Remove the KNX bus connection terminal from the device (see Fig. 22).
- 5 Optional: Disconnect the connecting terminal of the temperature sensor.

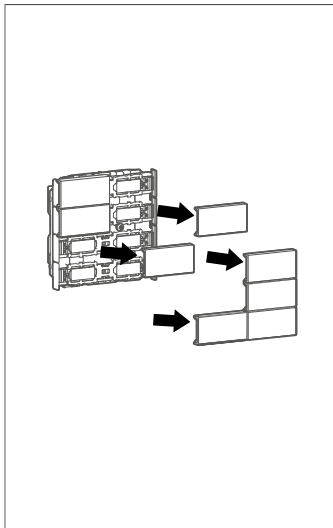

Fig. 19: Removing the buttons

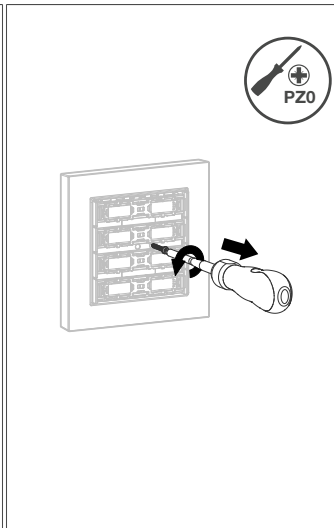

Fig. 20: Undoing the dismantling protection screw

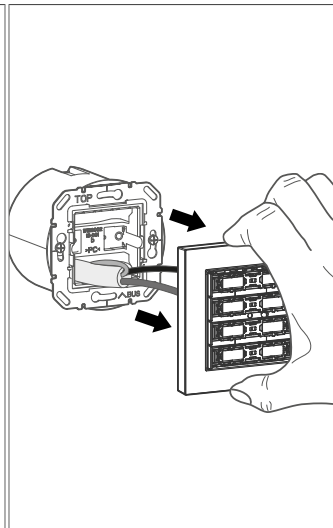

Fig. 21: Removing the device from the supporting ring

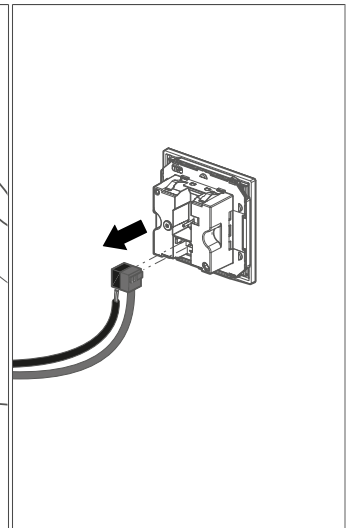

Fig. 22: Disconnecting the KNX bus connection terminal



Dispose of the device in line with the corresponding guidelines of the country (see [Disposal note](#)) or contact the point of sale for any warranty claim.

10 Appendix

10.1 Technical data

KNX Medium	TP1-256
Commissioning mode	system link, easy link
KNX supply voltage	21 ... 32 V $\overline{\text{SELV}}$
BUS connection mode	Bus connection terminal
KNX current consumption	Typ. 30 mA
Power consumption	typ. 150 mW
Degree of protection	IP20
Overvoltage class	III
Operating height	Max. 2000 m
Operating temperature	-5° ... +45°C
Storage/transport temperature	-20° ... +70°C
Dimensions	55 x 55 x 28 mm

10.2 Troubleshooting

Bus operation not possible.

Bus voltage is not present.

- 💡 Check bus connection terminals for correct polarity.
- 💡 Check the bus voltage by briefly pressing the programming button ([Fig. 5/8: Design and layout of the device](#)). The red LED lights up when bus voltage is available.

10.3 Accessories

Accessories mandatory

Cover for KNX push button, 1-gang	WAK7011xx
Cover for KNX push button, 1-gang, imprint	WAK7111xx
Cover for KNX push button, 1-gang, backlit	WAK7211xx
Cover for KNX push button, 4-gang	WAK7014xx
Cover for KNX push button, 4-gang, imprint	WAK7114xx
Cover for KNX push button, 4-gang, backlit	WAK7214xx
Cover for KNX push button, 6-gang	WAK7016xx
Cover for KNX push button, 6-gang, imprint	WAK7116xx
Cover for KNX push button, 4-gang, backlit	WAK7216xx
Cover for KNX push button, 8-gang	WAK7018xx
Cover for KNX push button, 8-gang, imprint	WAK7118xx
Cover for KNX push button, 8-gang, backlit	WAK7218xx

Optional accessories

Anti-theft protection PZO screw	WDA9091
KNX bus connection terminals, 2-pole, red/black	TG008
Floor temperature sensor	EK090
KNX system line Y(ST)Y, 2x2x0.8	TG01x

10.4 Disposal note



Correct Disposal of this product (Waste Electrical & Electronic Equipment).

(Applicable in the European Union and other European countries with separate collection systems).

This marking shown on the product or its documentation indicates that it should not be disposed of with other household waste at the end of its working life. To prevent possible harm to the environment or human health from uncontrolled waste disposal, please separate this device from other types of waste. Recycle the device responsibly to promote the sustainable reuse of material resources.

Household users should contact either the retailer where they purchased this product, or their local government office, for details of where and how they can take this device for environmentally safe disposal.

Business users should contact their supplier and check the terms and conditions of the purchase contract. This product should not be mixed with other commercial waste for disposal.



Berker GmbH & Co. KG

Zum Gunterstal

66440 Blieskastel

Germany

T +49 6842 945 0

F +49 6842 945 4625

info@hager.com

hager.com