

6LE09720A
8241506

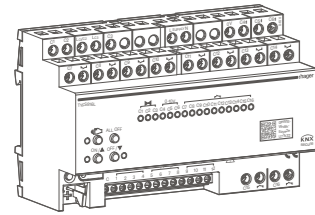

EN
IT
PT
SV

Quickguide

- EN Multi control module, 12 in. / 16 out.
- IT Modulo di controllo multifunzione 12 IN-PUT / 16 OUTPUT

- EL Πολυλειτουργικός ενεργοποιητής διαματιών 12 in. / 16 out.
- PT Módulo multifunções, 12 entradas / 16 saídas, KNX Secure
- SV Multikontrollmodul, 12 ingångar/16 utgångar, KNX Secure

TYFS816L
Multi control module, 12 in. / 16 out.

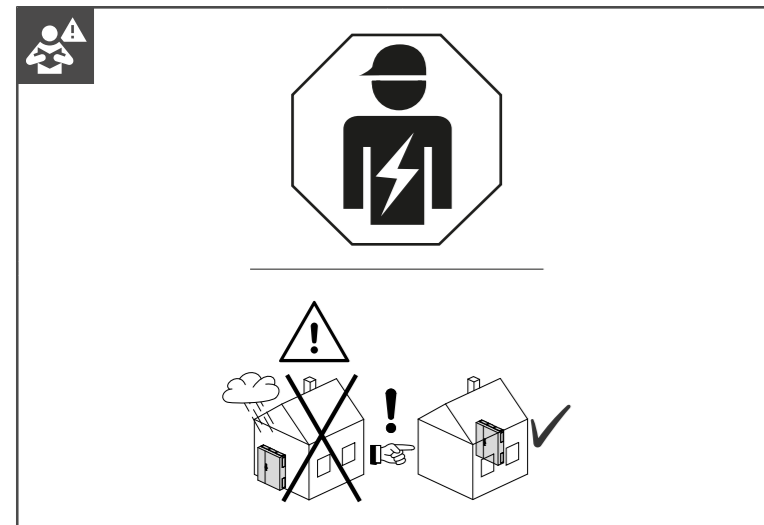

TP Bus 30V RF S KNX IP20

PZ1

ETS ≥ 5.7.7

More information
hgr.io/r/TYFS816L

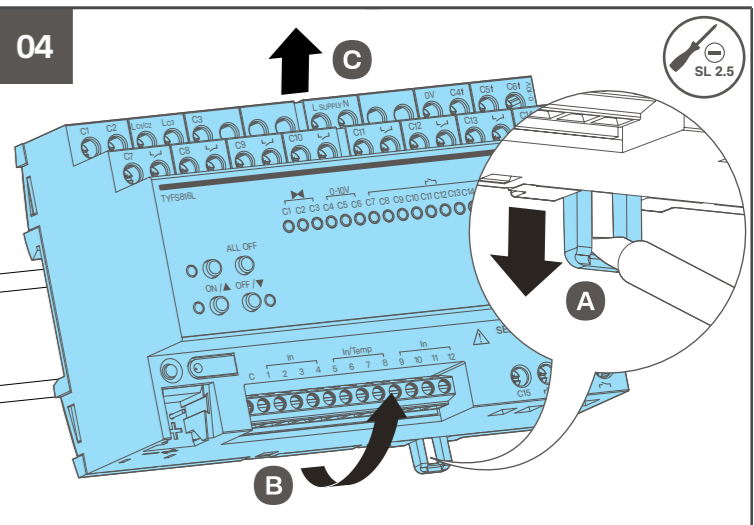
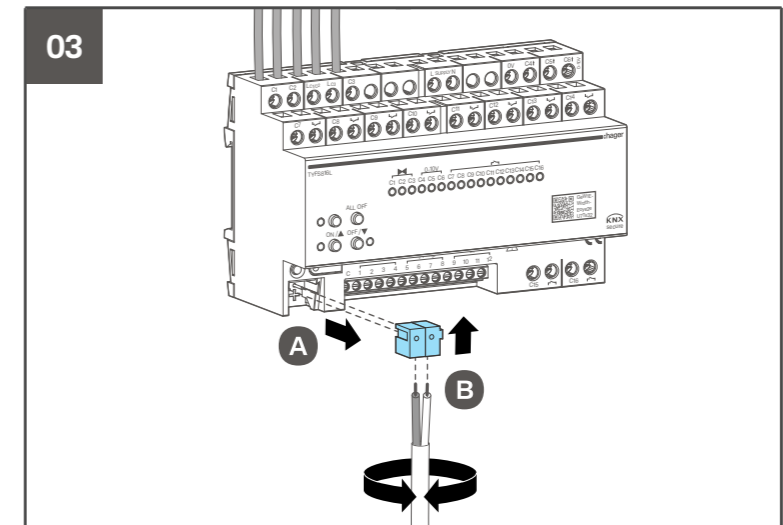
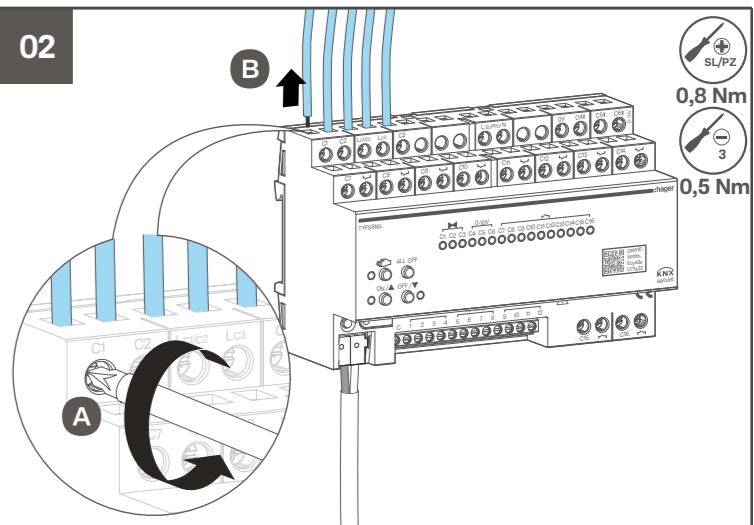
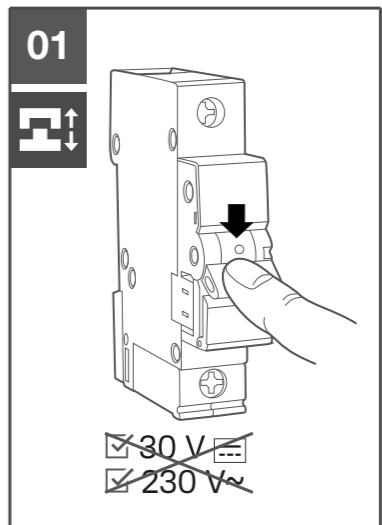
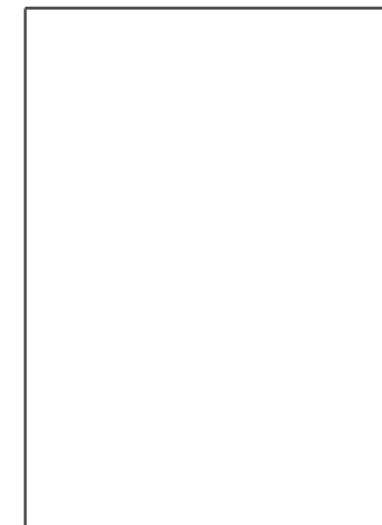
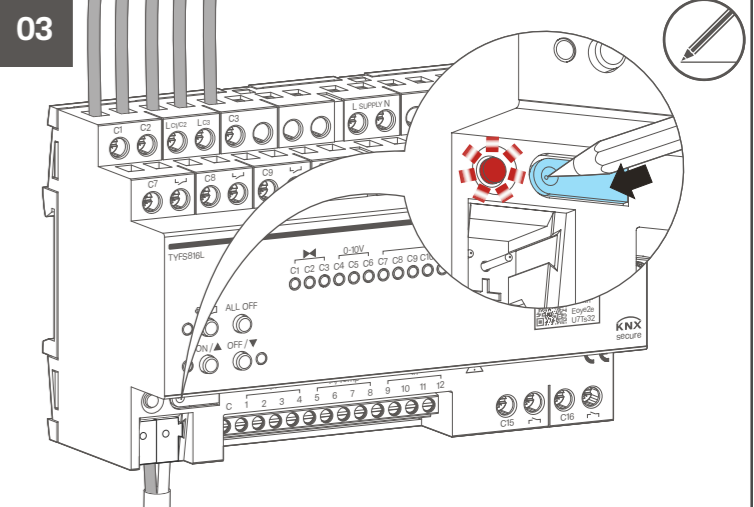
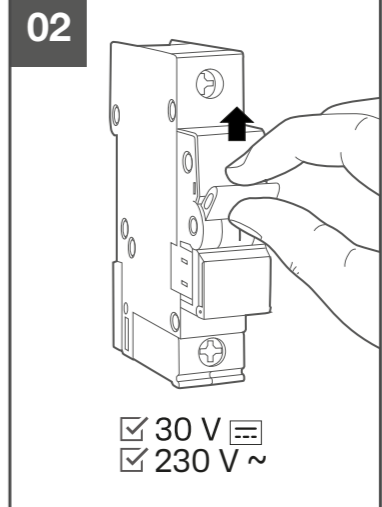
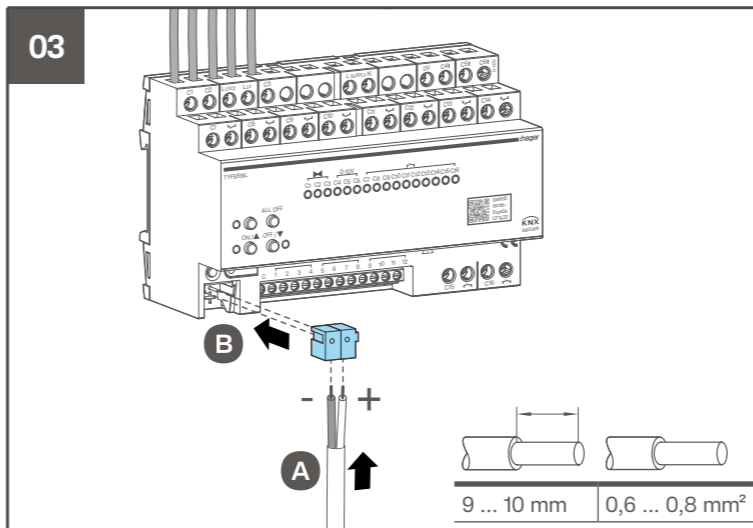
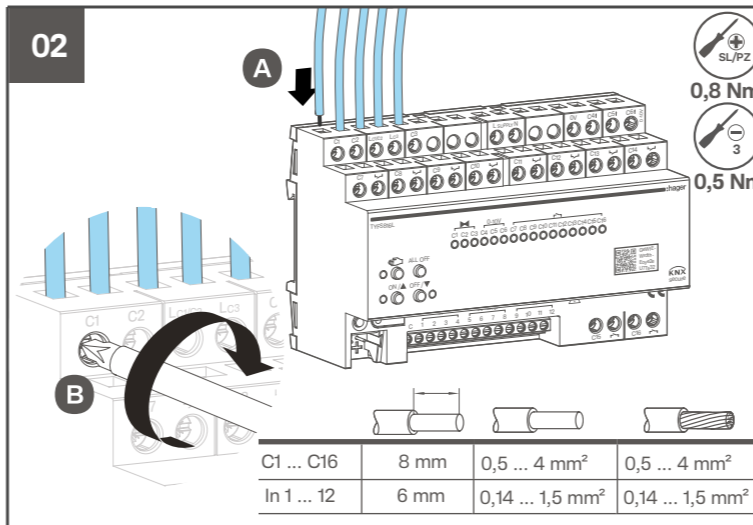
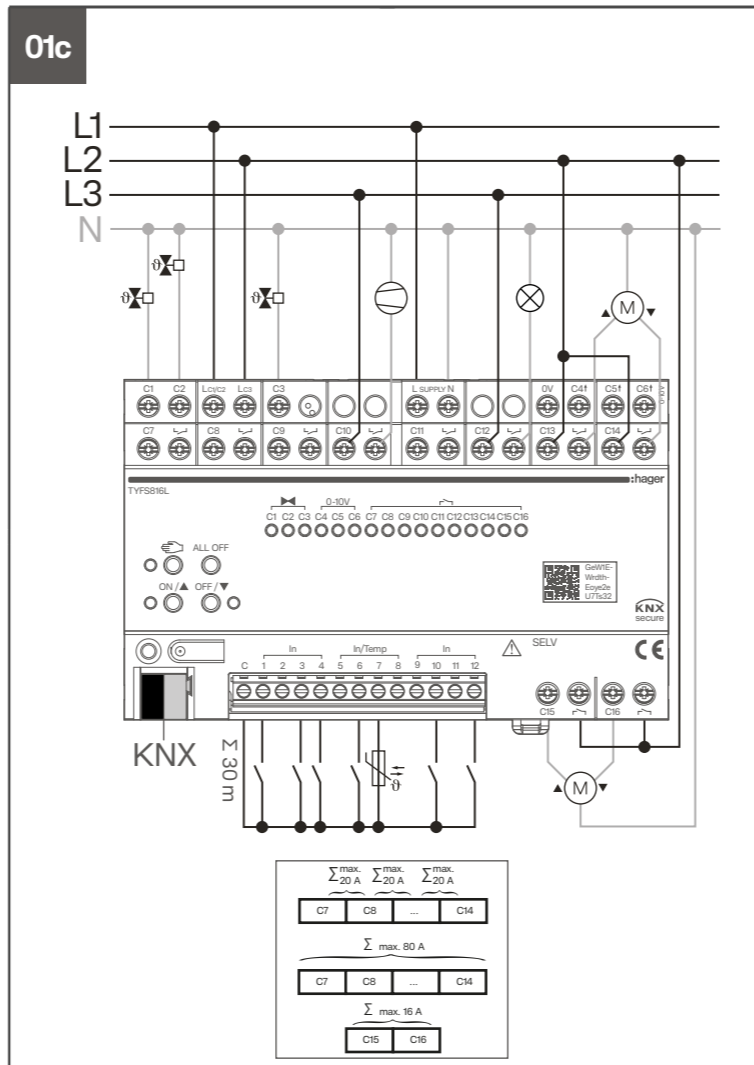
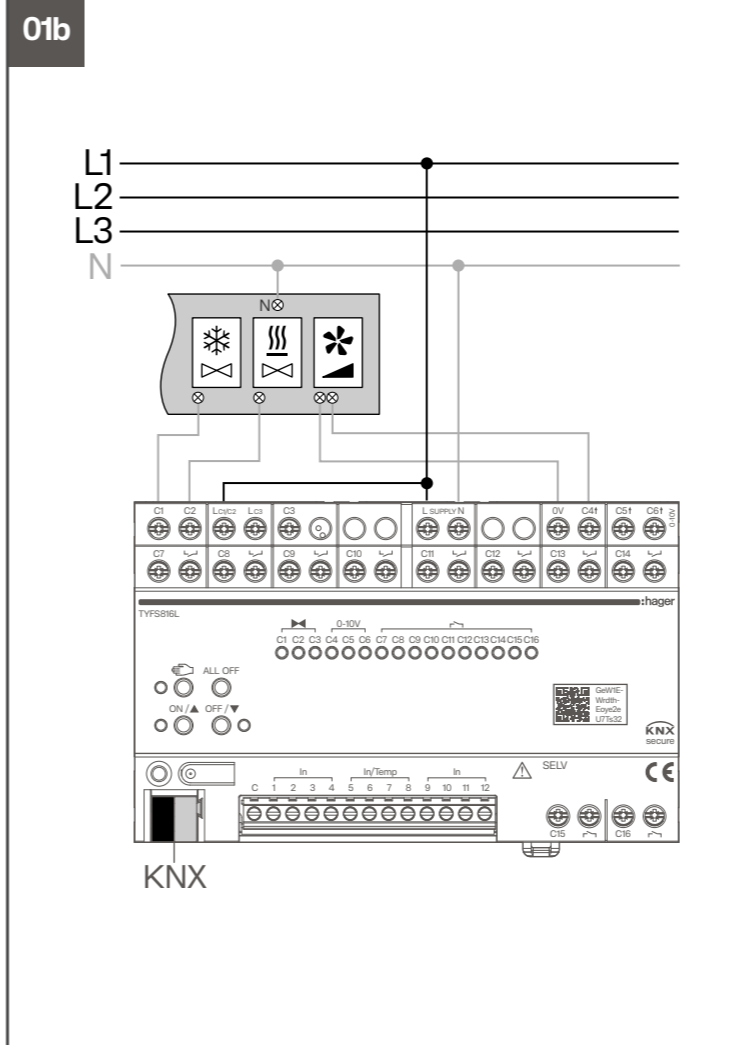
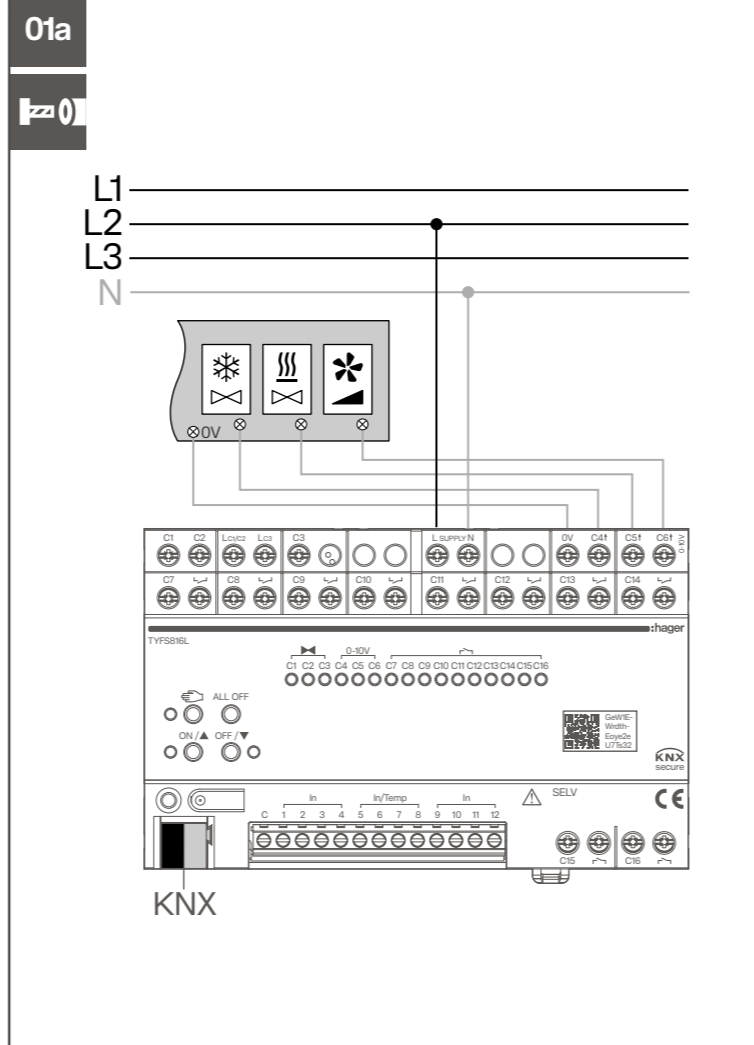
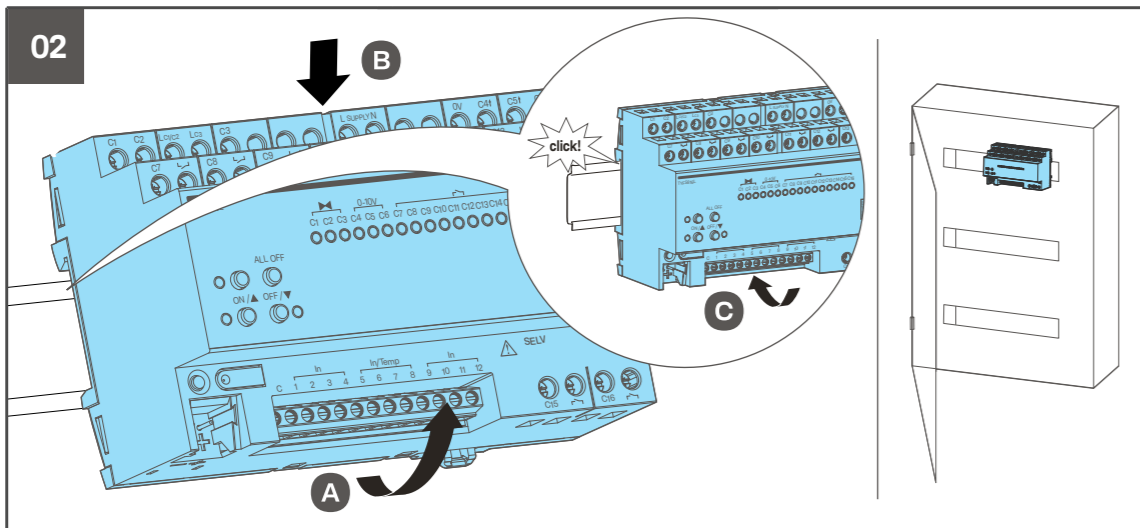
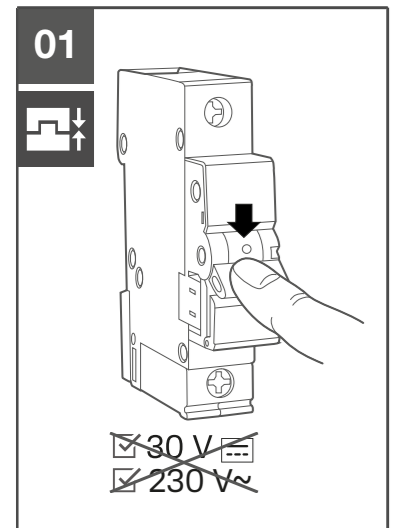
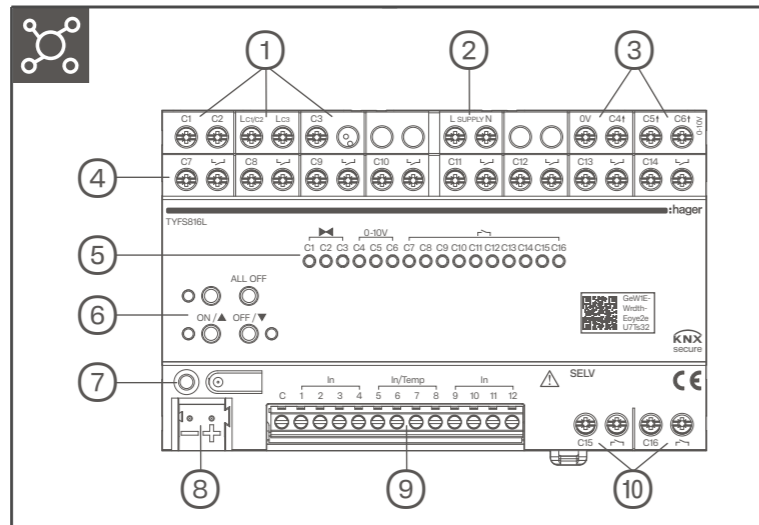
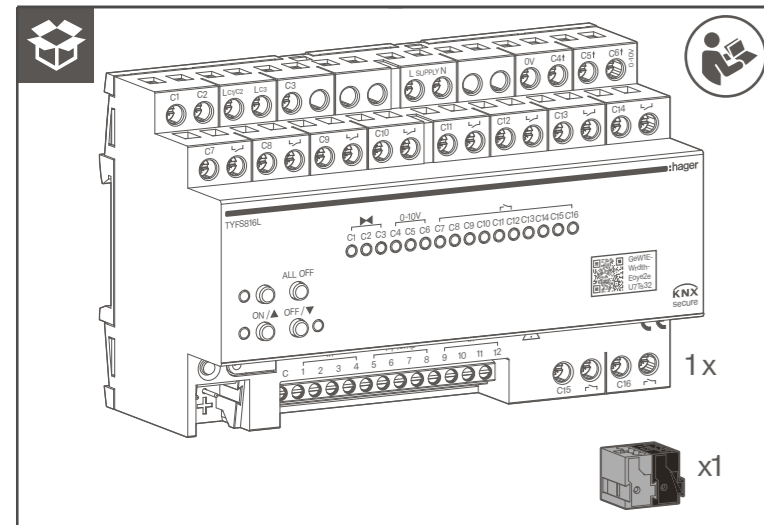

Supply L/N	AC 110/230V~ 50/60Hz
C1 ... C3	ε 10 W - 230V~ / 5 W - 110V~
C4 ... C6	0-10 V DC / 10 mA
In1 ... 4 / In9 ... 12	5 V DC SELV / max. 3,2 mA
In/Temp 5 ... 8	5 V DC SELV / max. 3,2 mA

	C7 ... C14
min	100 mA - 230V~ / 100 mA - 110V~
	3680 W - 230V~ / 1840 W - 110V~
	3680 W - 230V~ / 1840 W - 110V~
	3000 W - 230V~ / 1500 W - 110V~
	3000 W - 230V~ / 1500 W - 110V~
	400 W - 230V~ / 200 W - 110V~
	max 6A - 230V~ / max 3A - 110V~

	C15 ... C16
min	100 mA - 230V~ / 100 mA - 110V~
	1000 W - 230V~ / 500 W - 110V~
	1000 W - 230V~ / 500 W - 110V~
	1000 W - 230V~ / 500 W - 110V~
	1000 W - 230V~ / 500 W - 110V~
	400 W - 230V~ / 200 W - 110V~
	max 3A - 230V~ / max 1,5A - 110V~

EN Safety instructions

Electrical devices must only be installed and assembled by a qualified electrician in accordance with the relevant installation standards, guidelines, regulations, directives, safety and accident prevention directives of the country. Failure to comply with these installation instructions may result in damage to the device, fire or other hazards. These instructions are an integral component of the product and must be retained by the end user.

Design and layout of the device

- Valve outputs
- Connection of mains voltage power supply
- Analogue outputs 0–10 V
- Relay outputs C7 ... C14
- Status LEDs, outputs C1 ... C16
- Button panel for manual operation
- Programming button and programming LED
- KNX connection
- Extension units
- Relay outputs C15/C16

Correct use

- Switching of electric loads 230 V AC
- Switching of electric motors 230/240 V AC
- Control of 0–10-V loads
- Inputs to poll conventional, dry contacts
- Sending of telegrams on the KNX bus (reporting statuses, counter levels etc.)
- Installation on DIN rail according to IEC 60715

Installation and electrical connection

	Danger
	Electric shock when live parts are touched!
	An electric shock can lead to death!
	<ul style="list-style-type: none">Disconnect all connection cables before working on the device and cover any live parts in the area!

	Caution
	Impermissible heating if load of the device is too high!
	The device and the connected cables may get damaged in the connection area!
	<ul style="list-style-type: none">Do not exceed the maximum current carrying capacity!

	Caution
	Risk of destruction with parallel connection of several motors on one output!
	Final position switches could fuse together. Motors, hangings and the device may be destroyed!
	<ul style="list-style-type: none">Only connect one motor per output!

- Install the device on the DIN rail and connect it. Bus connection terminals must be located at the bottom.

Commissioning

systemlink: Loading the physical address and application software

- For detailed information on commissioning in systemlink or KNX Secure mode, please refer to the product-specific QR code.

Technical data	
KNX Medium	TP1-256
KNX supply voltage	21 ... 32 V SELV
Auxiliary tension	110/230 V~ +10/-15%; 50/60 Hz
Surge voltage	4 kV
Power dissipation	Max. 14 W
KNX current consumption	14...24 mA
Interlock time if direction of travel changes	Software-dependent
Operating height	Max. 2000 m
Degree of contamination	2
Operating temperature	-5° ... +45°C
Dimensions	8 modules, 8 x 17,5 mm

IT Istruzioni di sicurezza

L'installazione di apparecchi elettrici deve essere eseguita esclusivamente da un installatore qualificato in base alle norme di installazione, alle direttive, alle condizioni e alle disposizioni antinfortunistiche e di sicurezza in vigore nel paese. Il mancato rispetto delle istruzioni per l'installazione può provocare danni all'apparecchio, incendi o altri pericoli. Queste istruzioni per l'uso sono parte integrante del prodotto e devono restare in possesso dell'utilizzatore finale.

Disegno e struttura del dispositivo

- Uscite valvole
- Collegamento dell'alimentazione tensione di rete
- Uscite analogiche 0-10 V
- Uscite relè C7 ... C14
- LED di stato, uscite C1 ... C16
- Pannello dei tasti per il funzionamento manuale
- Tasto di programmazione e LED di programmazione

- collegamento KNX
- Scatole di derivazione
- Uscite relè C15/C16

Uso conforme alle indicazioni

- Commutazione delle utenze elettriche 230 V CA
- Commutazione dei motori elettrici 230/240 V CA
- Controllo delle utenze 0-10 V
- Ingressi per contatti puliti a potenziale libero convenzionali
- Invio di telegrammi sul bus KNX (report degli stati, livelli dei contatori, ecc.)
- Installazione sulla guida DIN in conformità con IEC 60715

Installazione e collegamento elettrico

	Pericolo
	Scosse elettriche in caso di contatto con componenti sotto tensione!
	Una scossa elettrica può portare alla morte!
	<ul style="list-style-type: none">Prima di svolgere lavori sul dispositivo, scollegare tutte le linee collegate e coprire i componenti sotto tensione nella zona circostante!

	Attenzione
	Riscaldamento non consentito se il carico del dispositivo è troppo elevato!
	Il dispositivo e i cavi collegati possono subire danni nell'area di collegamento!
	<ul style="list-style-type: none">Non superare il carico ammissibile massimo della corrente!

	Attenzione
	Rischio di danneggiamento in caso di collegamento in parallelo di più motori su un'uscita!
	I finecorsa potrebbero danneggiarsi. I motori, le tende e l'apparecchio potrebbero venire danneggiati irrimediabilmente!
	<ul style="list-style-type: none">Collegare esclusivamente un motore ad ogni uscita!

- Installare il dispositivo sulla guida DIN e collegarlo. I morsetti di collegamento bus devono trovarsi in basso.

Messa in servizio

systemlink: Scaricare l'indirizzo fisico e il software applicativo

- Per informazioni dettagliate sulla messa in funzione nella modalità systemlink o KNX Secure, consultare il codice QR specifico del prodotto.

Dati tecnici	
Strumento KNX	TP1-256
Tensione di alimentazione KNX	21 ... 32 V SELV
Tensione ausiliaria	110/230 V~ +10/-15%; 50/60 Hz
Tensione d'isolamento	4 kV
Potenza dissipata	Max. 14 W
Consumo di corrente KNX	14...24 mA
Tempo di interblocco in caso di cambio di direzione di marcia	Dipendente dal software
Altitudine massima di funzionamento	Max. 2000 m
Grado di inquinamento	2
Temperatura d'esercizio	-5 °C ... +45 °C
Dimensione	8 moduli, 8 x 17,5 mm

PT Instruções de segurança

Os dispositivos elétricos têm de ser instalados e montados por um electricista qualificado, de acordo com as normas de instalação, orientações, regulamentos, diretivas e regulamentos de segurança e prevenção de acidentes relevantes do país. O não cumprimento destas instruções de instalação pode resultar em danos no dispositivo, incêndio ou outros perigos. Estas instruções são uma parte integrante do produto e devem ser retidas pelo utilizador.

Desenho e esquema do aparelho

- Saídas para válvulas
- Ligação da alimentação da tensão de rede
- Saídas analógicas de 0–10 V
- Saídas relés C7 a C14
- LEDs de estado das saídas C1 a C16
- Botões para comando manual
- Botão e LED de programação
- Ligação KNX
- Extensões
- Saídas relés C15/C16

Utilização correta

- Comutação de cargas elétricas de 230 V A
- Comutação de motores elétricos de 230/240 V A
- Controlo de cargas de 0–10 V
- Entradas para verificação de contactos secos convencionais
- Envio de telegramas no bus KNX (comunicação de estados, níveis de contadores, etc.)
- Instalação em calhas DIN, de acordo com a norma IEC 60715

	Perigo
	Choque elétrico em caso de contacto com partes sob tensão!
	Um choque elétrico pode causar a morte!
	<ul style="list-style-type: none">Desligue todos os cabos e cubra todas as peças sob tensão na área, antes de efetuar trabalhos no produto!

	Cuidado
	Aquecimento excessivo se a carga do produto for demasiado elevada!
	O produto e os cabos ligados podem ficar danificados !
	<ul style="list-style-type: none">Não exceda a corrente máxima!

	Cuidado
	Risco de destruição em caso de ligação em paralelo de vários motores numa saída!
	Os interruptores de fim de curso podem fundir-se. Os motores, os mecanismos e o aparelho podem ser destruídos!
	<ul style="list-style-type: none">Ligar apenas um motor por saída!

- Instale o aparelho na calha DIN e ligue-o. Os bornes de ligação de bus devem situar-se na parte inferior.

Colocação em funcionamento

systemlink: Carregamento do endereço físico e do software da aplicação

- Para obter informações detalhadas sobre a colocação em funcionamento no modo systemlink ou KNX Secure, consulte o código QR específico do produto.

Dados técnicos	
Meio KNX	TP1-256
Tensão de alimentação KNX	21 a 32 V SELV
Tensão auxiliar	110/230 V~, +10/-15%; 50/60 Hz
Tensão de choque	4 kV
Potência dissipada	Máx. 14 W
Consumo de corrente KNX	14 a 24 mA
Tempo de bloqueio se a direção de deslocamento mudar	Dependente do software
Altura de operação	Máx. 2000 m
Grau de poluição	2
Temperatura de funcionamento	-5 a +45 °C
Dimensões	8 módulos, 8 x 17,5 mm

SV Säkerhetsinstruktioner

Elektriska enheter får enbart installeras och monteras av en kvalificerad elektriker i enlighet med gällande standarder, riktlinjer, bestämmelser och direktiv för installation samt säkerhets- och olycksförebyggande direktiv i landet. Underlåtenhet att följa dessa installationsanvisningar kan leda till skador på enheten, till brand eller andra risker. Dessa instruktioner är en integrerad del av produkten och måste bevaras av slutanvändaren.

Enhetens design och layout

- Ventilutgång
- Anslutning av nätspänningsförsörjning
- Analoga utgångar 0–10 V
- Reläutgångar C7 ... C14
- Status-LED-lampor, utgångar C1 ... C16
- Knappanel för manuell drift
- Programmeringsknapp och programmerings-LED
- KNX-anslutning
- Expansionsenhet
- Reläutgångar C15/C16

Korrekt användning

- Omkoppling av elektriska belastningar 230 V AC
- Omkoppling av elmotorer 230/240 V AC
- Styrning av belastningar på 0–10 V
- Ingångar för polling av konventionella kontakter
- Telegram på KNX-bussen (statusrapportering, räknarnivåer osv.)
- Montering på DIN-skena enligt IEC 60715

Installation och elektrisk anslutning

	Fara
	Elektrisk stöt när strömförande delar vidrörs!
	En elektrisk stöt kan leda till dödsfall!
	<ul style="list-style-type: none">Koppla bort alla anslutningskablar före arbeten på enheten och täck över alla strömförande delar i området!

	Försiktighet
	Otillåten uppvärmning om belastningen på enheten är för hög!
	Enheten och de anslutna kablarna kan skadas i anslutningsområdet!
	<ul style="list-style-type: none">Överskrid inte den maximala strömbelastningskapaciteten!

	Försiktighet
	Risk för att motorn förstörs vid parallell koppling av flera motorer i en utgång!
	Ändlägesbrytare kan smälta ihop. Motorer, hängare och enheten kan förstöras!
	<ul style="list-style-type: none">Anslut endast en motor per utgång!

- Fixera enheten på DIN-skenan och anslut den. Bussanslutningsklämmorna måste vara placerade nertill.

Driftsättning

systemlink: Läser in den fysiska adressen och applikationsprogramvaran

- For detaljerad information om driftsättningen i systemlink eller KNX Secure-läget hänvisas till den produktspecifika QR-koden.

Tekniska data	
KNX-medium	TP1-256
Matarspänning för KNX	21 ... 32 V SELV
Hjälpsspänning	110/230 V~ +10/-15 %, 50/60 Hz
Stötspänning	4 kV
Effektförlust	Max. 14 W
Strömförbrukning KNX	14 ... 24 mA
Föreglingstid om köriktningen ändras	Programvaruberoende
Drifthöjd	Max. 2000 m
Kontamineringsgrad	2
Drifttemperatur	-5° ... +45°C
Mått	8 moduler, 8 x 17,5 mm

EL Oδηγίες ασφαλείας

Oι εργασίες εγκατάστασης και συναρμολόγησης ηλεκτρικών συσκευών επιτρέπεται να εκτελούνται αποκλειστικά από επαγγελματίες ηλεκτρολόγο μηχανικό σύμφωνα με τα ισχύοντα σχετικά πρότυπα εγκατάστασης, κατευθυντήριες γραμμές, κανονισμούς, οδηγίες, οδηγιές ασφάλειας και πρόληψης ατυχημάτων της χώρας. Η μη συμμόρφωση με αυτές τις οδηγίες εγκατάστασης μπορεί να προκαλέσει ζημιά στη συσκευή, πυρκαγιά ή άλλους κινδύνους. Αυτές οι οδηγίες αποτελούν αναπόσπαστο μέρος του προϊόντος και πρέπει να φυλάσσονται από τον τελικό χρήστη.

Σχεδιασμός και διάταξη της συσκευής

- Έξοδοι ηλεκτροβανών
- Σύνδεση τάσης δικτύου
- Αναλογικές έξοδοι 0-10 V
- Έξοδοι ρελέ C7 ... C14
- LED κατάστασης, έξοδοι C1 ... C16
- Μπουτόν χειροκίνητου ελέγχου

- Μπουτόν και λυχνία LED προγραμματισμού
- Σύνδεση KNX
- Ψηφιακές εισοδοι
- Έξοδοι ρελέ C15/C16

Ορθή χρήση

- Έλεγχος ηλεκτρικών φορτίων 230 V AC
- Έλεγχος ηλεκτρικών μοτέρ 230/240 V AC
- Έλεγχος φορτίων 0-10V
- Είσοδοι για ζήρες επαφές (π.χ. διακόπτες, μπουτόν, αισθητήρες)
- Αποστολή τηλεγραφημάτων στο KNX bus (αναφορά καταστάσεων, μετρητές, κλπ)
- Εγκατάσταση σε ράγα τοποθέτησης σύμφωνα με το IEC 60715

Εγκατάσταση και ηλεκτρική σύνδεση

	Κίνδυνος
	Κίνδυνος ηλεκτροπληξίας σε περίπτωση επαφής με μέρη υπό τάση!
	Η ηλεκτροπληξία μπορεί να οδηγήσει στον θάνατο!
	<ul style="list-style-type: none">Αποσυνδέστε όλα τα καλώδια σύνδεσης πριν από την εκτέλεση εργασιών στη συσκευή και καλύψτε όλα τα υπό τάση μέρη στον χώρο!

	Προσοχή
	Υπερθέρμανση εάν το φορτίο της συσκευής είναι πολύ υψηλό!
	Η συσκευή και τα συνδεδεμένα καλώδια ενδέχεται να υποστούν ζημιά στην περιοχή σύνδεσης!
	<ul style="list-style-type: none">Μην υπερβαίνετε το μέγιστο επιτρεπόμενο ρεύμα!

	Προσοχή
	Κίνδυνος καταστροφής σε περίπτωση παράλληλης σύνδεσης πολλών κινητήρων σε μία έξοδο!
	Οι επαφές ενδέχεται να κολλήσουν. Τα μοτέρ, οι κουρτίνες και η συσκευή μπορεί να καταστραφούν!
	<ul style="list-style-type: none">Συνδέστε μόνο ένα μοτέρ ανά έξοδο!

- Στερεώστε τη συσκευή στη ράγα τοποθέτησης και συνδέστε την. Οι ακροδέκτες σύνδεσης bus πρέπει να βρίσκονται στο κάτω μέρος.

Πρώτη λειτουργία

systemlink: Φόρτωση της φυσικής διεύθυνσης και του λογισμικού εφαρμογής

- Για λεπτομερείς πληροφορίες σχετικά τον προγραμματισμό ή την θέση σε λειτουργία του KNX Secure, ανατρέξτε στον κωδικό QR για το συγκεκριμένο προϊόν.

Τεχνικά δεδομένα	
Μέσο KNX	TP1-256
Τάση τροφοδοσίας KNX	21 ... 32 V SELV
Βοηθητική τάση	110/230 V~ +10/-15%; 50/60 Hz
Υπέρταση	4 kV
Απώλεια ισχύος	μεγ. 14 W
Κατανάλωση ρεύματος KNX	14...24 mA
Χρόνος αλλαγής κατεύθυνσης ρολού	Εξαρτάται από το λογισμικό
Ύψος λειτουργίας	Μέγ. 2000 m
Βαθμός ρύπανσης	2
Θερμοκρασία λειτουργίας	-5° ... +45°C
Διαστάσεις	8 στοιχεία πίνακα, 8 x 17,5 mm