

Operating and installation instructions

HVAC control

Temperature control

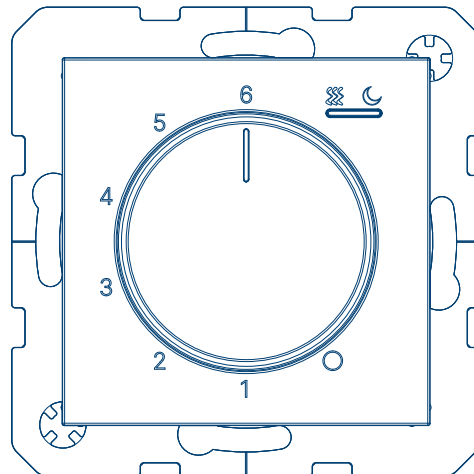

Electronic thermostat 230 V/15 W, heating/cooling

WAN5011xx

CE

:hager

1	Introduction.....	3
2	Safety instructions.....	5
3	Scope of delivery.....	6
4	Design and layout of the device.....	7
5	Function.....	8
5.1	Functional description.....	8
5.2	Correct use.....	8
5.3	Product characteristics.....	8
6	Operation.....	9
6.1	Control types.....	10
6.2	Open window detection.....	11
6.3	Status LEDs.....	12
6.4	Valve protection function.....	13
6.5	Frost protection/overheating protection.....	13
6.6	Factory settings.....	14
6.7	Eco mode.....	14
7	Information for qualified electricians.....	16
7.1	Connection and installation of the device.....	16
7.2	Configuration.....	17
7.3	Commissioning.....	20
7.4	Dismantling.....	20
7.4.1	Dismantling the device.....	20
8	Appendix.....	21
8.1	Technical data.....	21
8.2	Troubleshooting.....	21
8.3	NTC floor temperature sensor specification.....	22
8.4	Disposal note.....	23

1 Introduction

These instructions describe the safe and correct installation and commissioning of the thermostat. These instructions are provided as information in addition to the product.

Symbols used

- Single-step instruction or any sequence.
- ① Multi-step instruction. Sequence must be maintained.
- List
- ▶ Reference to additional documents/information









	Scope of delivery		Installation by a qualified electrician
	Suitable for use throughout Europe and Switzerland		Directive 2012/19/EU on waste electrical and electronic equipment

Table 1: Symbols used

Symbol	Warning word	Consequence of non-observance
	Danger	Leads to serious injuries or death.
	Warning	Can lead to serious injuries or death.
	Caution	Can lead to minor injuries.
	Caution	Can lead to device damage.
	Note	Can lead to physical damage.

Introduction

Symbol	Description
	Warning against electric shock.
	Warning against damage from electricity.
	Electronic devices may only be assembled, installed and configured by a specialist with electrical training and certification in accordance with the relevant installation standards of the country. The accident prevention regulations valid in the appropriate countries must be complied with.

These instructions are also aimed at electrically trained specialists in the field of sanitary, heating and air conditioning technology.

2 Safety instructions

Electrical devices may only be installed and assembled by a qualified electrician in accordance with the relevant installation standards, guidelines, regulations, directives, and safety and accident prevention regulations of the country of installation.

Failure to comply with these installation instructions may result in damage to the device, fire or other dangers.

3 Scope of delivery

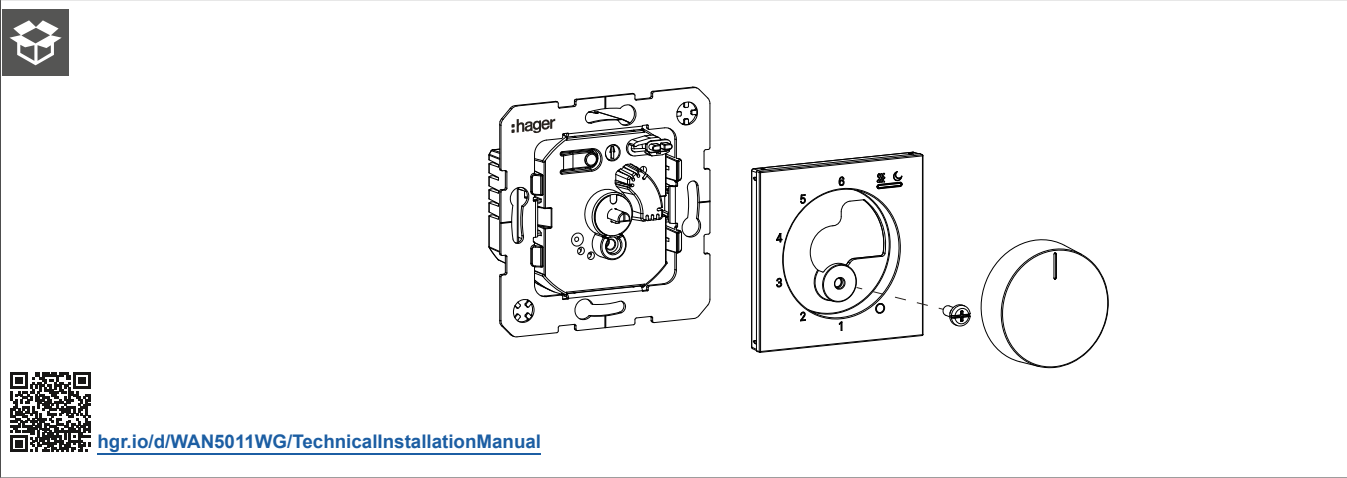

Fig. 1: Scope of delivery WAN5011xx

4 Design and layout of the device

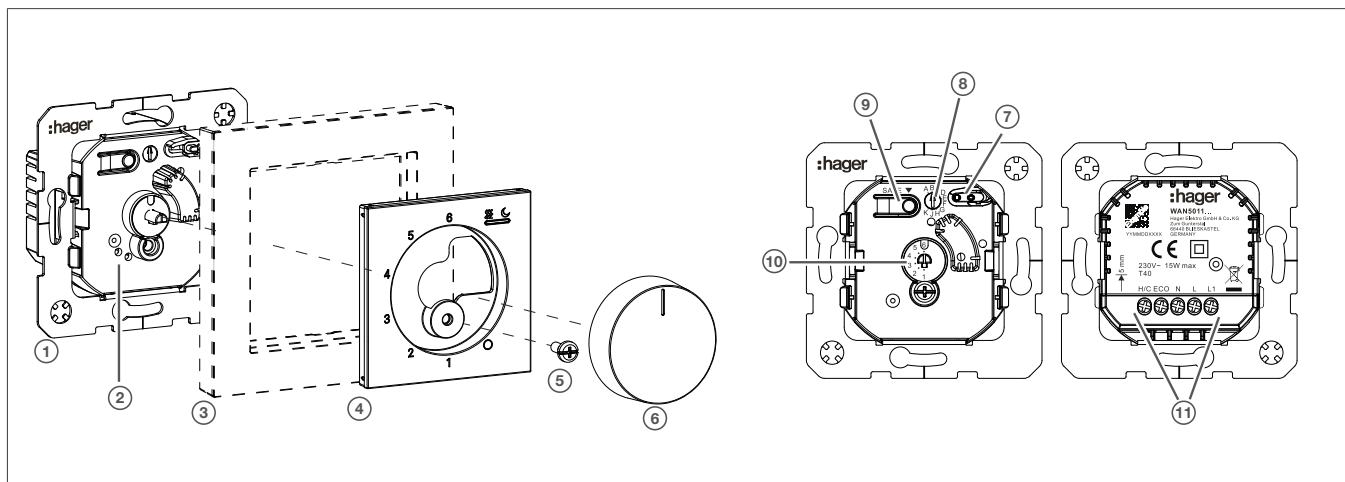

Fig. 2: Design and layout of the device

- ① Supporting ring
- ② Thermostat inserts
- ③ Frame (not in scope of delivery)
- ④ Centre piece
- ⑤ Fastening screw
- ⑥ Setting knob
- ⑦ Status LED
- ⑧ **MENU** selection switch
- ⑨ **SAVE** button
- ⑩ Adjusting knob
- ⑪ Connecting terminals

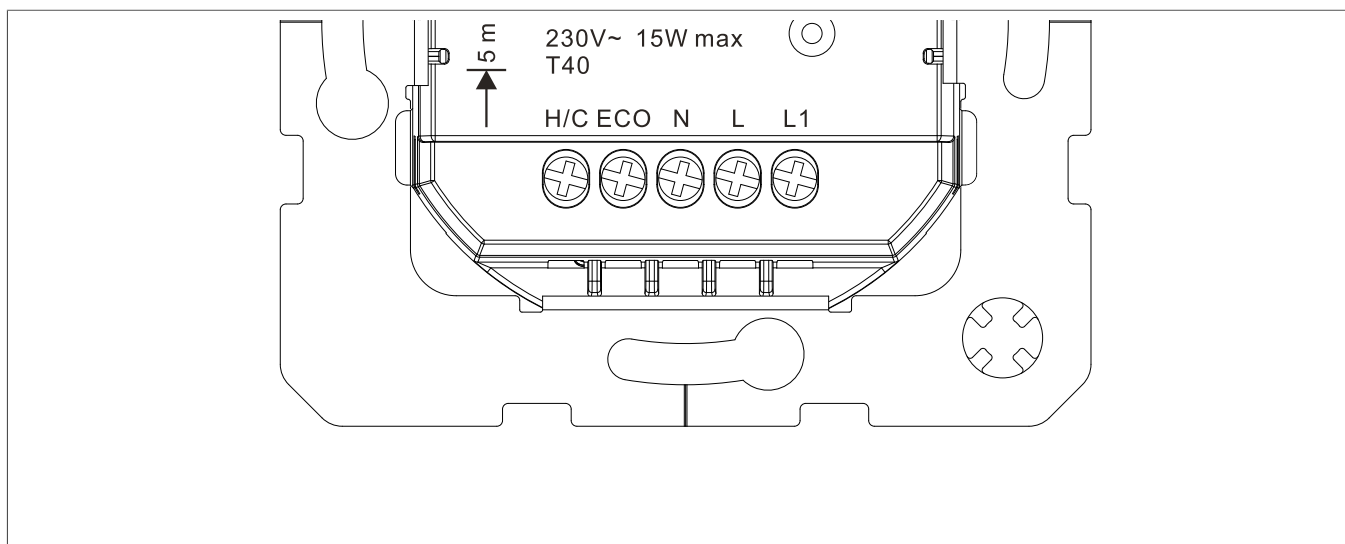

Fig. 3: Detailed view of connection terminals

5 Function

5.1 Functional description

The thermostat controls the room temperature in enclosed spaces. It is controlled using the measured value provided by the internal temperature sensor.

The thermostat can be individually configured using the **MENU** selection switch and the **adjusting knob**.

5.2 Correct use

- Controlling room temperature (heating/cooling)
- Only suitable for indoor applications
- Mounting in 60 mm windproof wall box

5.3 Product characteristics

- Manual adjustment of the comfort temperature
- Temperature limitation of the comfort temperature can be adjusted
- Manual deactivation of temperature control
- Input terminal for activating the setback temperature (ECO) via the central clock
- Internal temperature sensor
- Overheating protection
- Frost protection function
- Open window function
- Mode of operation of control output: Pulse width modulation (PWM) or two-point
- Valve protection function (1 x weekly opening and closing of the valve)
- Two status LEDs
- Status LEDs can be switched off

6 Operation

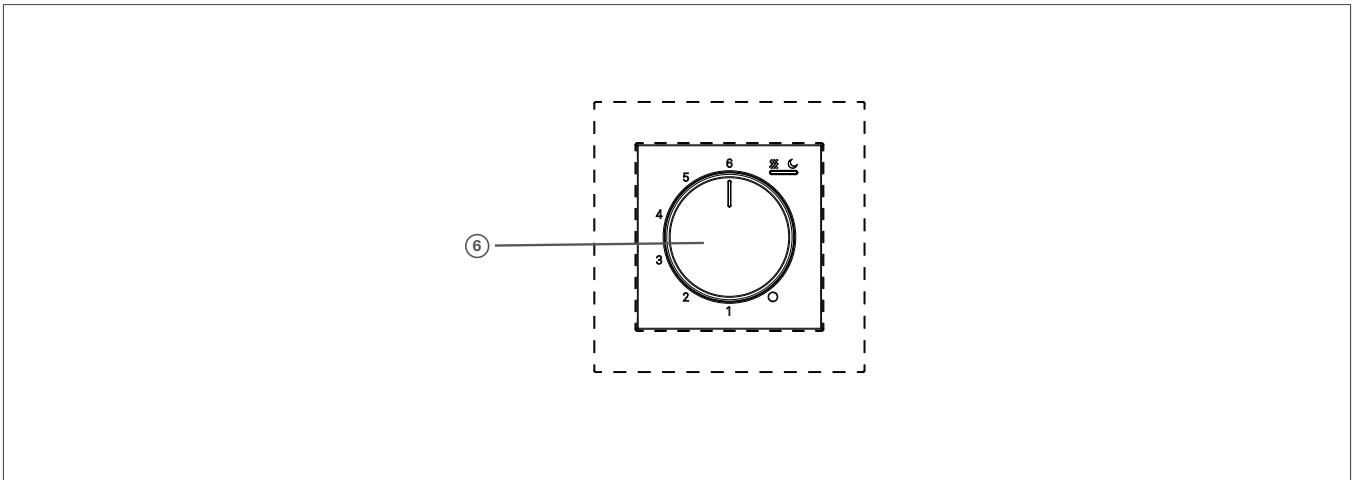

Fig. 4: Control elements

⑥ Setting knob

Switching the device on/off and setting the temperature value (Fig. 4/6)

- Turn the setting knob to position **0**: The device is switched off.
- Press the setting knob briefly: The device switches ECO mode on or off.
- Press and hold the setting knob: The device switches the status LEDs on or off.
- Turn the setting knob: The temperature value is changed.

Heating/cooling mode

The device can switch between heating and cooling mode. The connection conditions (see Connection and installation of the device) must be observed.

An energised H/C connection terminal means cooling mode. If this connection terminal is not energised, the device is in heating mode.

Setting the temperature setpoint

Specify the room temperature setpoint using the setting knob:

- Heating:
When the setpoint is undershot, the device switches on.
- Cooling:
When the setpoint is exceeded, the device switches on.

The setting range is max. 5°C to 30°C.

Setting value (scale)	0	1	2	3	4	5	6
Temperature value [°C] *	OFF	5	10	15	20	25	30

Table 2: Setting values on the setting knob

* Only valid in the default setting

The set temperature assigned to mark 6 is the highest permissible temperature and mark 1 is the lowest permissible temperature. The set temperatures are scaled linearly along the 180 degrees.

- Turn the setting knob to the desired setting.

Eco mode

Eco mode reduces the heating or cooling output in the room to save energy and costs. The device sets a lower room temperature than the comfort temperature set manually on the device. Eco mode can be activated manually on the device or automatically via a time switch, for example.

The device switches to Eco mode when the Eco connection is switched from de-energised to energised and exits Eco mode when the Eco connection is switched from energised to de-energised.

The user can switch Eco mode on and off by pressing the setting knob (6). This function can be deactivated in the settings.

The device follows the last request with a certain logic. This means that pressing the setting knob (6) takes precedence over the status of the Eco connection immediately before it was pressed. However, if the connection status changes after pressing the setting knob (6), the connection status takes precedence.

If the setting knob (6) for the set temperature is **not** in the **OFF position** and **Eco mode is activated**, the set temperature in heating mode will drop by 4°C compared to the setpoint set with the setting knob and will rise by 4°C in cooling mode. The Eco mode LED lights up. The Eco mode logic is subject to the minimum and maximum temperatures specified in the settings.

If the setting knob for the set temperature is in the **OFF position** and **Eco mode is activated**, the **set temperature does not change** (either 'OFF' or 'Frost protection' as defined in the settings). The Eco mode LED remains lit.

6.1 Control types

The device can be operated in two different control modes.

- 2-point control mode (2PT)
- Pulse width modulation (PWM) - factory setting



To ensure good controllability of the system, it is recommended to use pulse width modulation (PWM) as the control mode.



2-point control mode

The 2-point control mode or the 2-point controller is the simplest of the two controller types in terms of operation. The controller can only switch the thermostat ON or OFF. The controller switches the output value on if the setpoint is undershot, or turns it off if the setpoint is exceeded (heating).

The controller is equipped with an in-built hysteresis in order to prevent the it from constantly switching the output value on and off. The controller calculates the switch-on and switch-off points using the hysteresis and the current setpoint. The hysteresis value is also stored permanently and cannot be changed directly on the device. In the menu settings, it is possible for the specialist craftsman to adjust the hysteresis value to the conditions.

The 2-point controller should be used where the output value can only accept the two states ON or OFF and the actual temperature does not have to be controlled precisely to the setpoint.

Due to the inertia of the heating system, the actual temperature swings slightly below the set switch-on point and exceeds the set switch-off point slightly. The actual temperature therefore always fluctuates in the 2-point controller within a range which is slightly greater than the set hysteresis.

When 2PT is selected, the difference between the switch-on and switch-off points must be set in a range of 0.5k to 1.2k.

Example:

If the setpoint is 20°C and the 2PT value 1.0k is selected, heating starts below 19.5°C and stops above 20.5°C.

Switching PI-control (PWM)

The switching PI control (PWM), pulse wide modulation control, also has continuous PI control. However, with such a control, the output signal (0 to 100%) of the PI control is not passed on to the output value, but is only processed internally. The PWM control subsequently converts the output value from the output signal of the PI control into a switch on/off pulse. However, this switch on/off pulse does not have a fixed switch on/off point as with the 2-point control, but the length of the pulses is determined by means of the output value calculated by the PI control (cycle time). The larger the calculated output value of the PI control, the greater is the ratio of the switch on/off times.

The cycle time is permanently stored in the system for the PWM control. The cycle time is the time which comprises a cycle, that is to say the duration of a switch on/off pulse (Fig. 0). The duration of the switch-on pulse is calculated from the product of the calculated output value and cycle time, e.g. for a cycle time of 10 min. and a calculated output value of 70%, the switch-on pulse is: $0.7 \times 10 \text{ min} = 7 \text{ min}$. The remaining 3 minutes of the cycle are therefore dedicated to the switch-off pulse. A short cycle time causes the switch-on pulses to occur at fairly short intervals. This prevents the temperature from lowering too much and the actual value remains stable.

The PWM control provides fairly good control results because it retains the advantages of continuous PI control (control to desired setpoint, no overshoot) in spite of limited switching states. For instance, one application field is electrothermal drives.

The time period for the work cycle is between 5 and 30 minutes.

The time period for the work cycle is between 15 and 30 minutes.

6.2 Open window detection

Open window detection detects a sudden change in room temperature when a window is opened. If a temperature drop of 5°C is detected within 15 minutes, the **open window detection** function is executed.

Window detection is defined as follows:

- ☑ Open window detection is activated on the device.
- The room temperature drops by 5°C within 15 minutes.
 - Open window is detected.
 - The set temperature is changed to the lowest permissible setpoint.
 - The right status LED flashes green.

Open window detection is cancelled by the following events:

- The measured air temperature is higher than the previously measured air temperature (0.1°C after 1 minute of filtration).
- 30 minutes after 'Open window' is detected.
- By pressing or turning the setting knob.

If the open window detection function is cancelled, the room temperature is reset based on the position of the setting knob and the flashing of the status LED is stopped

6.3 Status LEDs

Switching off the status LEDs

The status LEDs can be switched off permanently, e.g. night mode.

Switching off the status LEDs permanently

- Press and hold the setting knob for more than 3 s.
The status LEDs are permanently switched off.



If status LEDs permanently switched off mode/night mode is active, the LEDs are switched on briefly and automatically switched off again when the device is operated.

Switching the status LEDs back on

- Press and hold the setting knob for more than 3 s.
- The status LED display is activated.



This setting is stored in a non-volatile memory. The settings are stored and are available after a power failure.

The device has two status LEDs (7) that indicate the status of the device during operation and the status of the device during configuration by the installer.

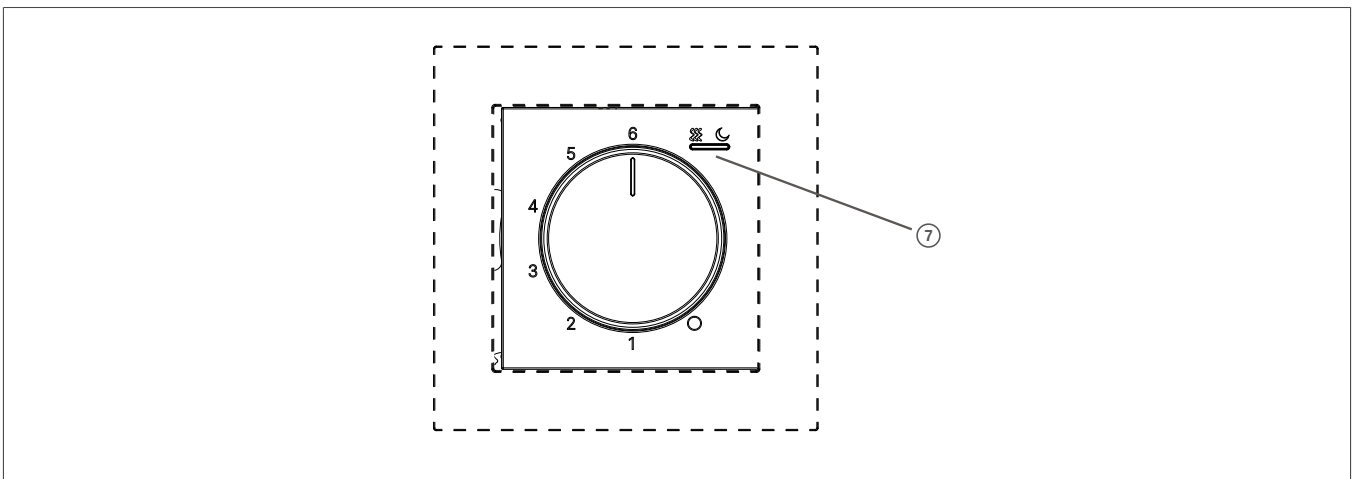

Fig. 5: Status LED view

Status LED display in normal operating mode

Status LED, left

Heating mode	ON	LED lights up permanently in red
	OFF	LED is off
Cooling mode	ON	LED lights up permanently in blue
	OFF	LED is off

Table 3: Heating/cooling mode - left status LED

Status LED, right

ECO mode	ON	LED lights up permanently in green
	OFF	LED is off

Table 4: ECO mode - right status LED

Status LED, right

Open window detection	Open window detection has triggered	LED flashes green
	Open window detection cancelled	LED is off

Table 5: Open window detection — right status LED

6.4 Valve protection function

The device has a valve protection function that prevents the valve from sticking by regularly opening and closing it completely.

If a radiator thermostat is not operated within a period of 7 days/168 hours, the radiator thermostat is automatically opened and closed completely once.

6.5 Frost protection/overheating protection

Frost protection (if activated)

- Frost protection means that in a heating system, the frost protection function is carried out automatically when the room temperature drops below 5°C to prevent freezing of the water in the heating pipes or the entire heating system.

Overheating protection (if activated)

- ▶ Overheating protection means that in a cooling system, the protection against overheating is carried out automatically when the room temperature rises above the value of 40°C in order to protect people and animals from heat

If the setting knob (6) is in position 0-Off and frost protection and/or overheating protection is deactivated, all **outputs are always switched off**.

If frost protection/overheating protection is activated and the setting knob is in position 0-Off, the following temperature settings apply:

- If the frost protection temperature falls below 5°C, heating mode is activated.
- If the temperature rises above 40°C, cooling mode is activated.

6.6 Factory settings

The device can be reset to the factory settings. Proceed as follows:



Caution

Resetting the device to the factory settings must only be carried out by a qualified specialist in electrical, sanitary, heating and ventilation technology.

- Turn the MENU selection switch (10) to position 6.
- Keep the **SAVE** button pressed for 10 s.

The device is reset to the parameters from the as-delivered state (factory setting).

The device is restarted.

6.7 Eco mode

Eco mode reduces the heating or cooling output in the room to save energy and costs. The device sets a lower room temperature than the comfort temperature set manually on the device. Eco mode can be activated manually on the device or automatically via a time switch, for example.

The device switches to Eco mode when the Eco connection is switched from de-energised to energised and exits Eco mode when the Eco connection is switched from energised to de-energised. The device checks the status of the ECO connection when it is switched on to determine the corresponding status.

The user can switch Eco mode on and off by pressing the setting knob (6). This function can be deactivated in the settings.



Caution

Changes to the factory settings must only be carried out by a qualified specialist in electrical, sanitary, heating and ventilation technology.

The device follows the last request with a certain logic. This means that pressing the setting knob (6) takes precedence over the status of the Eco connection immediately before it was pressed. However, if the connection status changes after pressing the setting knob (6), the connection status takes precedence.

If the setting knob (6) for the set temperature is **not** in the **OFF position** and **Eco mode is activated**, the set temperature in heating mode will drop by 4°C compared to the setpoint set with the setting knob and will rise by 4°C in cooling mode. The Eco mode LED lights up. The Eco mode logic is subject to the minimum and maximum temperatures specified in the settings.

If the setting knob for the set temperature is in the **OFF position** and **Eco mode is activated**, the **set temperature does not change** (either 'OFF' or 'Frost protection' as defined in the settings). The Eco mode LED remains lit.

When the device exits Eco mode, the LED must be switched off. Eco mode must not be stored in a non-volatile memory. After switching on, the value for Eco mode must be defined immediately by the status of the Eco connection.

7 Information for qualified electricians

7.1 Connection and installation of the device

Connection and installation of the device



Danger

Electric shock when live parts are touched!

An electric shock can lead to death!

- Disconnect all connection cables before working on the device and cover any live parts in the area!

Connect the device in heating or cooling mode

A 2 A miniature circuit breaker must be used to protect the device.

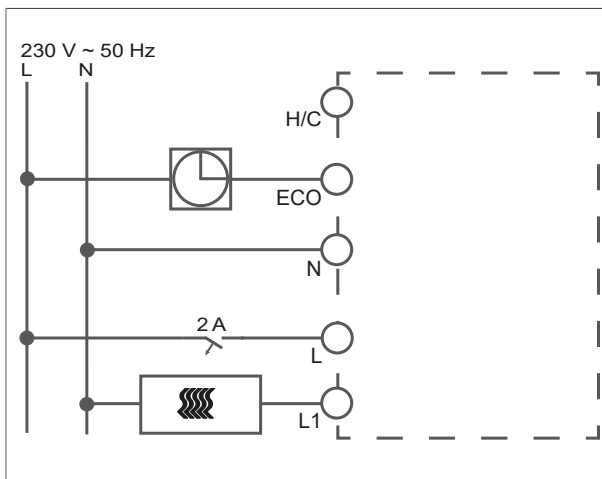

Fig. 6: Electrical connection for heating

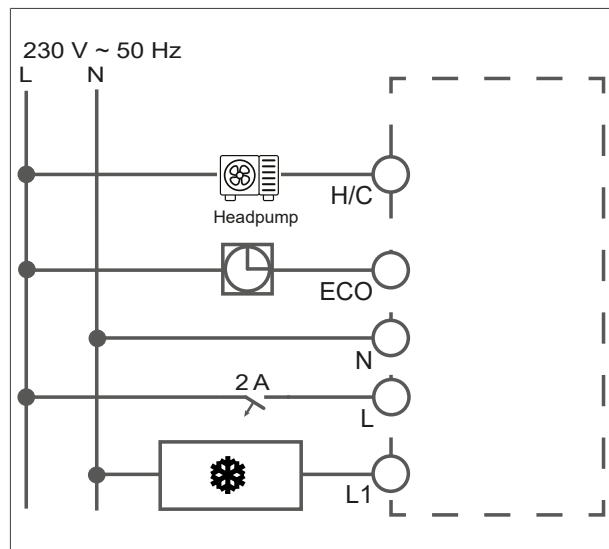

Fig. 7: Electrical connection for cooling

L - Outer conductor (phase)

N - Neutral conductor

L1 - Load connection, heating

ECO - Temperature reduction

H/C - Heating/cooling changeover contact

L - Outer conductor (phase)

N - Neutral conductor

L1 - Load connection, cooling

ECO - Temperature reduction

H/C - Heating/cooling changeover contact



The n-conductor must be connected to the thermal re-circulation as a power supply, otherwise large temperature variations should be expected.

☑ The flush-mounted or hollow-wall box is installed in the wall and plastered in.

- 1 Connect the controller for heating or cooling according to the connection diagram.
- 2 Mount the device on the wall box using the supporting ring.
- 3 Attach the frame and fix it in the correct position with the centre plate and fastening screw.
- 4 Attach the setting knob.

7.2 Configuration

Status LED display in configuration mode

During the individual configuration of the device, the two status LEDs indicate the selected menu and the set value in the selected menu by the number of flashes.

Status LED, right	If the position of the adjusting knob (8) is changed, the number of LED flashes corresponds to the value currently configured for the corresponding function.
Status LED, left	The number of LED flashes corresponds to the set value.

Table 6: Configuration mode - left/right status LED

MENU selection switch position (8)	A	B	C	D	E	F	G	H	J	K
Number of right status LED flashes	1	1	3	2	1	1	1	1	1	1
Default parameters	NO	PWM	20 min 1.0K	Inactive	Active	ON (5°C)	30	5	30	16

Table 7: Number of right status LED flashes

Example of changing the default parameters

- 1 Turn the **MENU** selection switch (8) to position A.
The right status LED indicates the default value by flashing green once.
- 2 Turn the adjusting knob (10) to position 3.
- 3 Keep the SAVE button (9) pressed for < 1 s.
The left status LED indicates the newly set value by flashing red three times.

Configuring the device

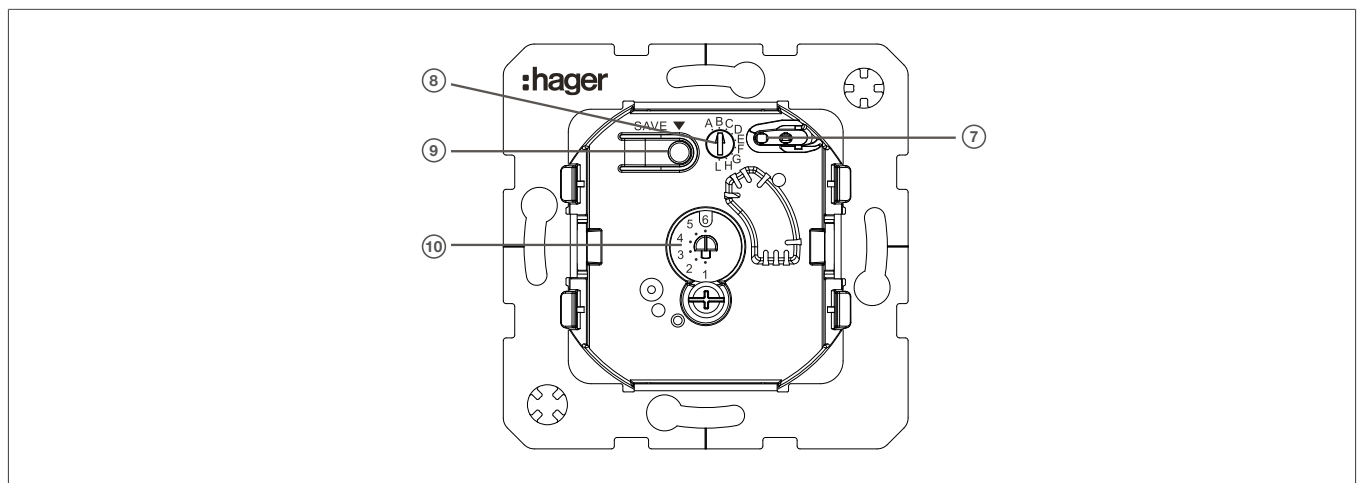

Fig. 8: Configuring the device

- ⑦ Status LED
- ⑧ **MENU** selection switch
- ⑨ **SAVE** button
- ⑩ Adjusting knob

The device can be individually configured before use. The configuration is set using the **MENU** selection switch and the adjusting knob. The **SAVE** button is used to save the settings.

The following table lists the setting parameters.

- Turn the **MENU** selection switch to the desired position (A ... K).
The status LED flashes as many times as corresponds to the configuration value.
- Turn the adjusting knob to position (1 ... 6).
- Keep the **SAVE** button pressed for 1 s.
Set values are stored and the status LED flashes as many times as corresponds to the configuration value.
- Repeat this process for the other parameters.

	Position of the setting potentiometer	Value
Contact type, NO/NC	A	1: NO * 2: NC
Selection of control type (PT/PWM)	B	1: PWM * 2: 2PT
Parameters for PWM	C	1: 5 min 2: 10 min 3: 20 min * 4: 30 min 1.2 K
Parameters for 2PT	C	1: 0.5 K 2: 0.8K 3: 1.0K * 4: 1.2K
Open window function	D	1: Active 2: Inactive *
Manual selection of ECO mode	E	1: Active * 2: Inactive
Frost protection	F	1: Active * 2: Inactive
Upper limit for heating	G	1: 30 * 2: 28 3: 26 4: 24 5: 22
Lower limit for heating	H	1: 5 * 2: 9 3: 12 4: 16 5: 18
Upper limit for cooling	J	1: 30 * 2: 29 3: 28 4: 27 5: 26
Lower limit for cooling	K	1: 16 * 2: 18 3: 20 4: 22 5: 24

Table 8: Setting parameters

* Default setting

Configuring open window detection

The open window detection function can be configured as follows.

Activating open window detection on the device

- Turn the **MENU** selection switch to position D, parameter **Active/inactive open window detection**.
The right status LED flashes twice for the currently set open window detection value.
- Turn the adjusting knob to position 1, open window detection active.
- Press and hold the **SAVE** button for 2 s.

The right status LED flashes once for the currently set open window detection value.

Open window detection is activated.

7.3 Commissioning



The controller requires a certain amount of time to adjust itself to the room temperature. For this reason, the switching point will deviate from the room temperature directly after installation. Switching point accuracy will only occur after approx. 1 to 2 operating hours.

After the first power-on or restart, the device switches on all LEDs for 2 seconds and then starts normal operation.

Commissioning the device (factory settings)

The device can be commissioned with the settings in the as-delivered state. The factory settings can be found in the table ([Tab. 8: Setting parameters](#)).

Operate the device as described in the **Operation chapter** ([6 "Operation"](#)).

7.4 Dismantling

7.4.1 Dismantling the device



Danger

Electric shock when live parts are touched!

An electric shock can lead to death!

- Disconnect all connection cables before working on the device and cover any live parts in the area!

The device is voltage-free. All live wires are switched off.

- 1 Remove the setting knob from the device.
- 2 Loosen the fastening screw while pulling the frame and the centre plate off the device.
- 3 Loosen the fastening screws and pull the device out of the wall box.
- 4 Loosen and disconnect the connecting cables.
- 5 Insulate the connecting cables.



Dispose of the device in line with the corresponding guidelines of the country ([see Disposal note](#)) or contact the point of sale for any warranty claim.

8 Appendix

8.1 Technical data

Switching element	Triac
Temperature range can be adjusted via rotary controls	5 ... 30°C
Nominal voltage	230 V AC
Frequency	50 Hz
Switching current	65 mA (15 W)
Switch on current	2 A
Power consumption standby mode	≤0.5 W
Switching capacity heating / cooling	15 W
Switching accuracy	~0.5 K
Built-in depth	32 mm
Operating temperature	-10 ... +40°C
Storage/transport temperature	-25 ... +70°C
Degree of contamination	2
Rated surge voltage	4 kV
ErP Energy class	IV
Mode of action	1 Y
Overvoltage category	III
Protection class (after complete installation of cover)	II
Conductor cross-section of screw terminals	1.5 mm ² ... 1 x 2.5 mm ²

8.2 Troubleshooting

Large temperature variations in control

No n-conductor connected.

💡 Connect the n-conductor.

The controller is poorly positioned.

💡 Change the position of the controller.

The temperature measurement is influenced by draughts in or through the wall box.

💡 Use a windproof wall box and find and eliminate the cause of draughts.

8.3 NTC floor temperature sensor specification

Resistance values of temperature sensors in ohms

Temperature [°C]	NTC 2K	NTC 10K EK090	NTC 12K	NTC 15K	NTC 33K
-10	8947	37614	63929	71478	207659
-5	7079	31395	49012	55778	155354
0	5642	26200	37942	43924	117358
5	4527	21412	29645	34887	89493
10	3657	17581	23364	27936	68838
15	2973	14502	18567	22543	53473
20	2431	12016	14871	18325	41854
25	2000	10000	12000	15000	33000
30	1654	8358	9752	12359	26209
35	1376	7016	7978	10248	20878
40	1151	5913	6569	8548	16744
45	967	5003	5442	7171	13539
50	816	4250	4535	6048	11010
55	693	3625	3800	5128	8990
60	590	3102	3201	4370	7382

Table 9: Resistance values in ohms

8.4 Disposal note



Correct disposal of this product (electrical waste).



(Applicable in the European Union and other European countries with separate collection systems)

This marking shown on the product or its documentation indicates that it should not be disposed of with other household waste at the end of its working life. To prevent possible harm to the environment or human health from uncontrolled waste disposal, please separate this device from other types of waste. Recycle the device responsibly to promote the sustainable reuse of material resources.

Household users should contact either the dealer where they purchased this product, or their local government office, for details of where and how they can take this device for environmentally safe disposal.

Commercial users should contact their supplier and check the terms and conditions of the purchase contract. This product should not be mixed with other commercial waste for disposal.



Berker GmbH & Co. KG

Zum Gunterstal

66440 Blieskastel

Germany

T +49 6842 945 0

F +49 6842 945 4625

info@hager.com

hager.com