

Operating and installation instructions

Switches and protective dev. NH fuse switch disconnecter

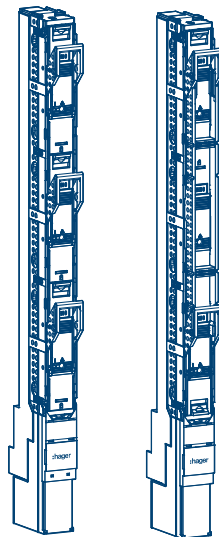

Size NH00/185 mm, flat
LV8*

fv+ CE

:hager

1	About these instructions.....	4
1.1	Target groups.....	4
1.2	Symbols used.....	4
2	Function.....	6
2.1	Intended use.....	6
3	Safety.....	7
3.1	Safety instructions.....	7
3.2	Requirements for operators.....	7
4	Scope of delivery and accessories.....	9
4.1	Scope of delivery and dimensions.....	9
4.2	Accessories.....	9
4.3	Design and layout of the device.....	11
5	Installation.....	12
5.1	Preparing installation.....	12
5.2	Installation with M8 screws.....	14
5.3	Installation using hooks.....	15
5.4	Installation of the IP2X-system devices.....	16
5.5	Completing installation.....	16
5.6	Installation of the touch protection cover and the blanking cover.....	18
6	Electrical connection.....	19
7	Fuse links.....	22
7.1	Inserting and removing fuse links.....	22
7.2	Fuse monitoring and testing.....	23
8	Completing the installation.....	25
8.1	Sealing.....	25
8.2	Labelling.....	25

9	Operation.....	27
9.1	Voltage absence test (VAT).....	27
9.2	Securing the device in closed position using a padlock.....	27
9.3	Unlocking the device in the closed position.....	28
9.4	Positioning the device in park position.....	30
9.5	Securing the device in park position using a padlock.....	32
9.6	Unlocking the device in the park position.....	33
9.7	Locking piece storage.....	34
10	Electronic fuse monitoring system.....	36
11	Appendix.....	40
11.1	Technical data.....	40
11.2	Disposal note.....	41

1 About these instructions

These instructions describe the safe and proper installation, commissioning and operation of the **fv+ NH00/185 mm flat** fuse switch disconnectors with product references LV8*. These instructions are part of the device. Keep the instructions for use throughout the life of the device and pass them on if necessary.

Read these instructions carefully before beginning all work and before using the fuse switch disconnectors. No warranty is accepted for damage caused by failure to follow these instructions.

i

Depending on the type of fuse switch disconnector, the depictions in these instructions may differ visually. If device-specific information is required, this is indicated at the appropriate point.

1.1 Target groups

All devices may only be assembled, installed and configured by a specialist with electrical training and certification in accordance with the relevant installation standards of the country. The accident prevention regulations valid in the appropriate countries must be complied with.

In addition, these instructions are intended for operators of systems with fuse switch disconnectors.

1.2 Symbols used

Symbol	Description
●	Instruction for a single step or in any order
①	Instruction for multiple step actions. The order must be followed.
①	Identification and description of device components
-	List
▶	Reference to documents / additional information

The symbols explained below are mainly used in the Quick Guide that is included in the product packaging.

	Contents of the packaging		Product dimensions		Required tools
	Device overview		Installation		Installation
	Installation/final installation		Settings		Mandatory accessories
	Optional accessories		Dismantling accessories		Mounting orientation can be rotated by 180°
	Correct execution		Part no longer needed/to be disposed of		Not included in scope of delivery
	Labelling		Must be installed by an electrician		Two-person assembly



Protective earth (IEC 60417-5019)



Applicable in all Europe and in Switzerland



Note on disposal of waste electrical and electronic equipment (WEEE)

Danger levels in warning information

Symbol	Signal word	Consequences in the event of non-compliance
	Danger	Causes serious injury or death.
	Warning	May cause serious injuries or death.
	Caution	May cause minor injury.
	Caution	May cause serious damage to the device.
	Note	May cause damage to the device.

In addition to the general warning symbol in accordance with ISO 7010 as shown above, additional warning symbols specifically representing the danger are used in the technical documentation for the product.

Symbol	Description
	Risk of electric shock.
	Risk of damage due to mechanical overload
	Risk of damage to the equipment due to electricity
	Risk of fire damage
	Risk of heating or overheating

Other symbols used

Symbols explained below are also derived from ISO 7010 and are used in the technical documentation for the product for information that requires special attention and urgent recommendations.

Symbol	Definition
	Important note
	Information that must be read before using the product
	Disconnect all live cables to the product

2 Function

The fv+ NH fuse switch disconnecter size 00 is a device designed to provide reliable protection against overloads and short circuits in low voltage systems by using NH fuse links, ensuring the safety of both people and electrical installations. In addition, it enables safe manual disconnection of circuits, even under load. It is suitable for use in main and sub distribution boards and is designed and tested according to IEC/EN 60947-3.

2.1 Intended use

NH00 fuse switch disconnectors with vertical design according to IEC/EN 60947-3 shall only be used as follows:

- For NH fuse links in sizes 00
- For vertical mounting on busbar systems with 185 mm centre-to-centre spacing
- Use silver-plated fuse links or solid links only
- For indoor use only or in suitable outdoor enclosures



Note

For many device variants the mounting orientation can be rotated by 180°.

Permitted environmental conditions

- Do not operate in areas that are at risk of explosion or flooding
- Maximum installation altitude: 2000 m above sea level
- Operating temperature range: -25 °C to 55 °C

3 Safety

3.1 Safety instructions



The instructions belonging to this device are a component part of the product and must be available to specialist personnel at all times.

Read and comply with the instructions.



Qualified electricians

The installation and maintenance of all devices may only be carried out by a qualified electrician in accordance with the relevant installation standards, guidelines, regulations, safety and accident prevention regulations of the country.



Danger

Danger due to electric shock

Risk of death or serious injury

- 1 Disconnect the device before carrying out any work on the device (all poles and all sides).
- 2 Lock the switching devices in the disconnect position. Take into account all circuit protection devices that supply dangerous voltages to the device.



Danger

Risk of electric shock if the device is to be installed or maintained under voltage

Risk of death or serious injury

- Wear appropriate personal protective equipment (PPE).



Attention

Failure to comply with these installation instructions may result in damage to the device or system.

- Maintenance work must only be carried out by a qualified electrician in accordance with national regulations.

3.2 Requirements for operators

The operator is responsible for the correct and safe use of the fuse switch disconnectors. The operator is only deemed to be using the fuse switch disconnectors in accordance with the correct use if they meet the requirements imposed on them and comply with the conditions for operating and maintaining the fuse switch disconnector as described in these instructions.

Every person who operates a system with fuse switch disconnectors must undergo safety training. This training must be provided by qualified and accredited specialists.

All electrical work must be carried out by qualified electricians only.

Procedures requiring specific knowledge (e.g. electrical, mechanical, construction) must only be carried out by specially trained personnel with the appropriate equipment for this work.

Keep all protective devices in good condition and in good working order.

4 Scope of delivery and accessories

4.1 Scope of delivery and dimensions

Scope of delivery

- Fuse rail
- Screws for cable connection (reference dependent)
- Quick Guide for installation

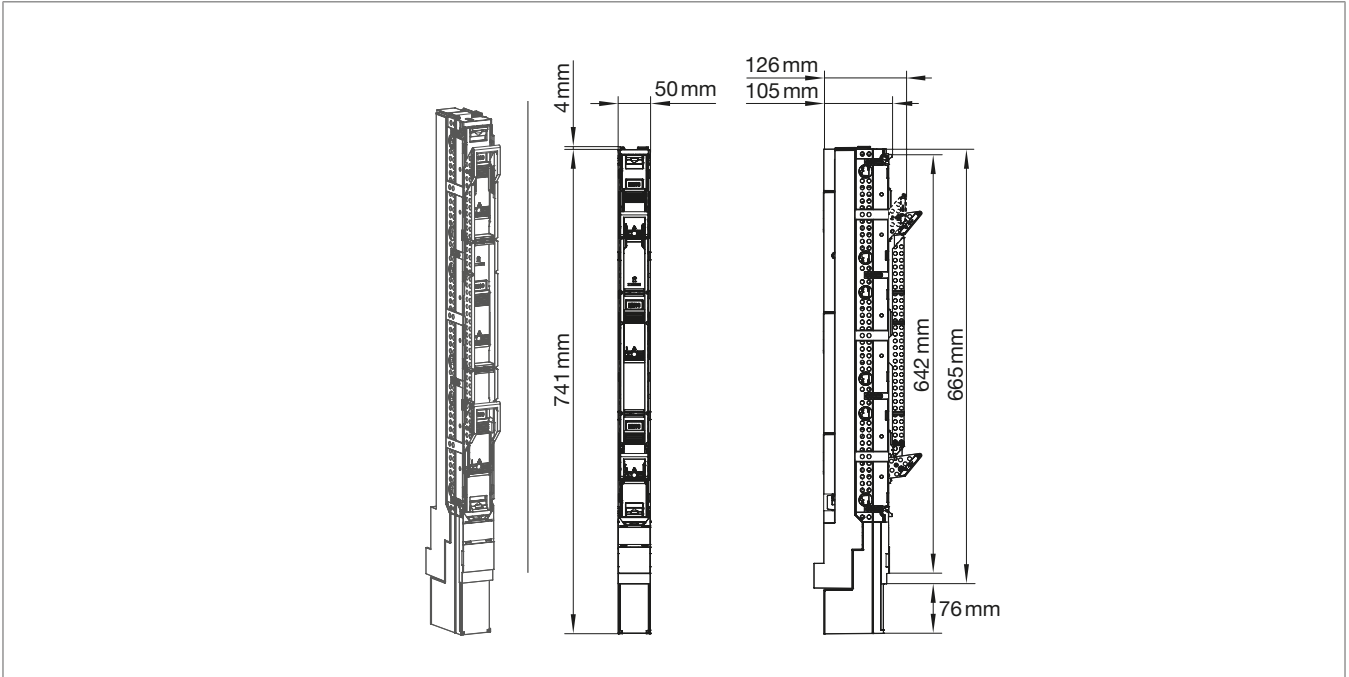

Figure: Dimensions

4.2 Accessories

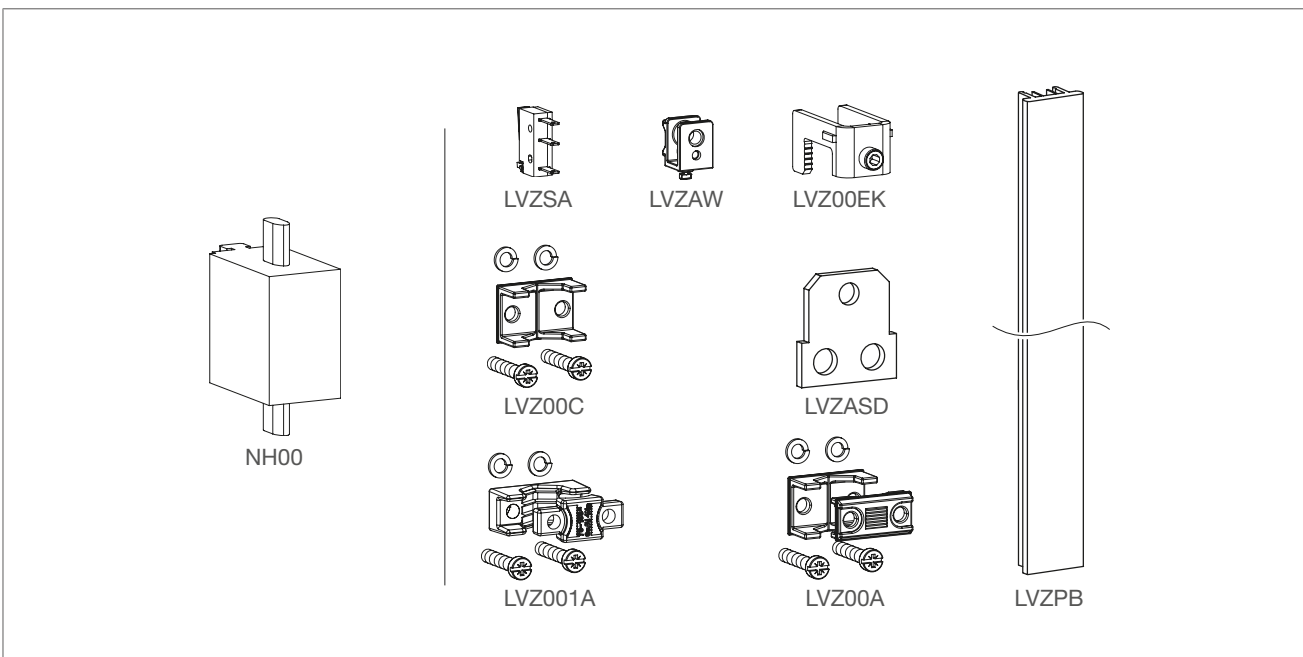
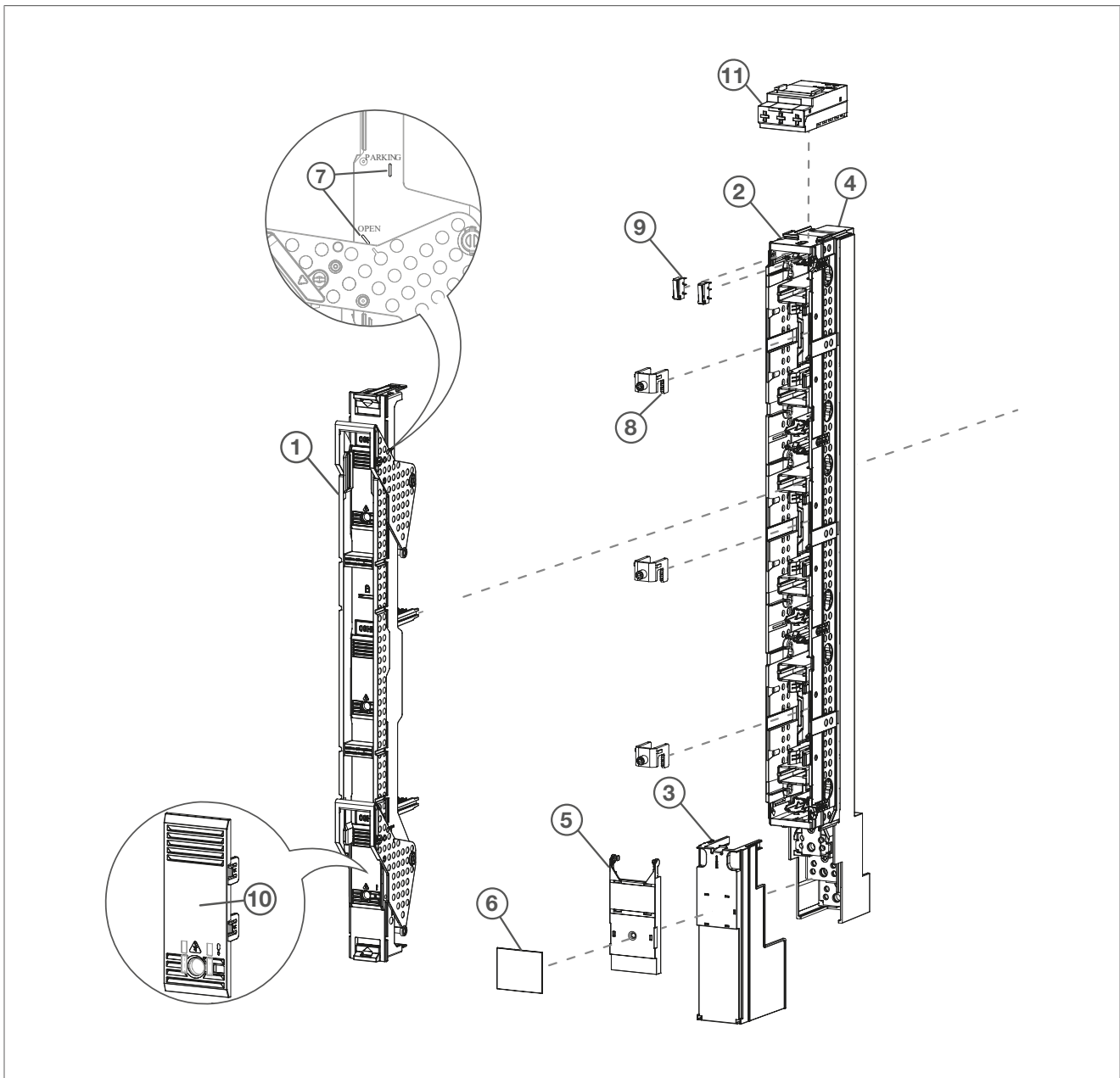

Figure: Accessories

Reference	Description
NH00	NH Fuse link size 00
LVZSA	Switch position indicator, microswitch opener and closer
LVZ00C	Pressure plates for cable direct connection 1,5-95 mm ² size 00
LVZ001A	Pressure plates prism for size 00 185mm; 70-150 mm ² ; corrosion-resistant
LVZAW	Angle bracket lateral for mounting the sideframes
LVZ00EK	Hook
LVZASD	Double connection lug size 00/185 for 2 conductors up to 35 mm ² , stainless
LVZ00A	Prisms connection 95 mm ² for size 00/60-100-185 mm, corrosion-resistant
LVZPB	Sideframe, 850 mm long, to cover the sides

This list includes the accessories mentioned in the technical documentation for the product. Hager expressly reserves the right to make changes or additions, even if these are not referred to in these instructions.

4.3 Design and layout of the device



- ① Fuse switch lid
- ② Fuse switch cage
- ③ Terminal cover
- ④ Fuse switch base
- ⑤ Nameplate holder
- ⑥ Nameplate (rotatable)
- ⑦ Handle position indicator
- ⑧ Hooks
- ⑨ Microswitch
- ⑩ Sliding window
- ⑪ Fuse monitoring

5 Installation

5.1 Preparing installation



Danger

Electric shock when live parts are touched!

An electric shock can lead to death!

- Before working on the device, disconnect the power supply. Consider all circuits that could supply the device with dangerous voltages.
- Lock the switching devices in the disconnect position.
- Use a suitable measuring device to check that the device is volt-free.
- During maintenance work, set up safety barriers and attach a hazard sign.
- It is essential to wear appropriate personal protective equipment (PPE) when working on live equipment.

Installation is done using screw fastening (M8) or a hook system.

Most assembly steps are identical for 3-pole and 1-pole fuse switch disconnectors. The differences are highlighted below.

- 1 Pull down the handle(s) to open the fuse switch lid (1). For the 3-pole version use both hands.
- 2 Press down the buttons on the fuse switch lid and remove it.

3-pole

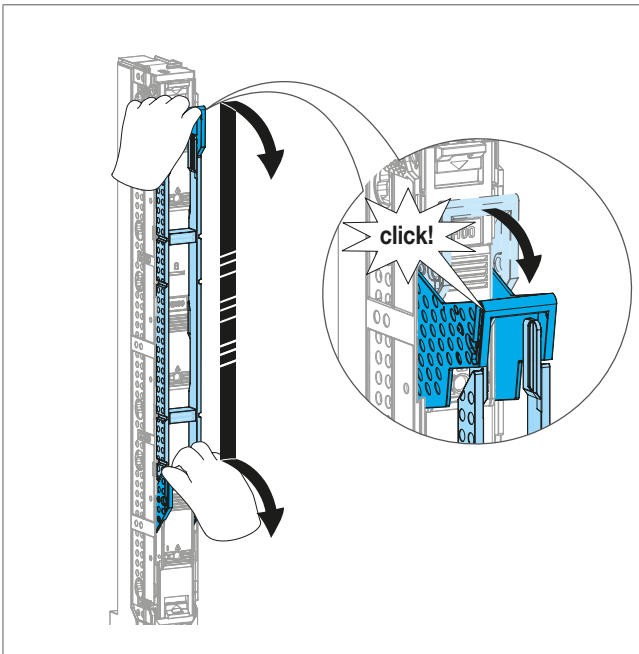

1-pole

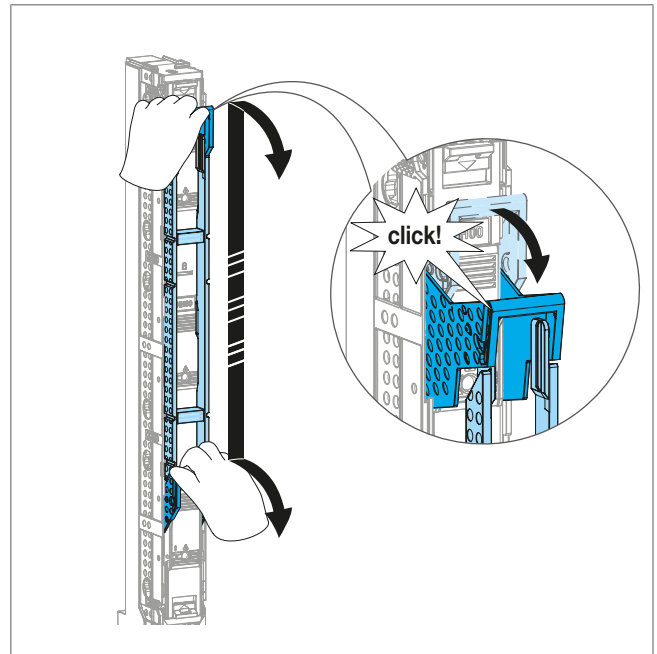

Figure: Removing the fuse switch lid

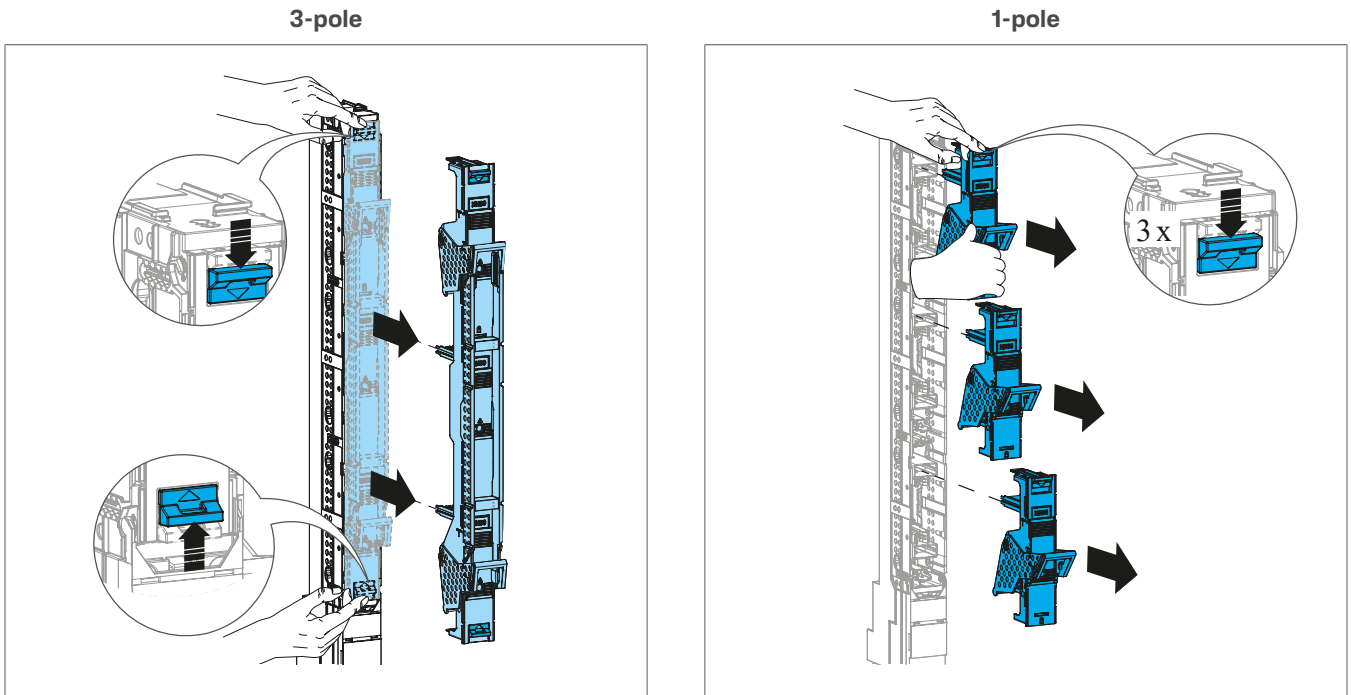

Figure: Removing the fuse switch lid

- 3 Insert a slotted screwdriver (2-6 mm) into the openings provided and carefully open the cover flaps downwards.

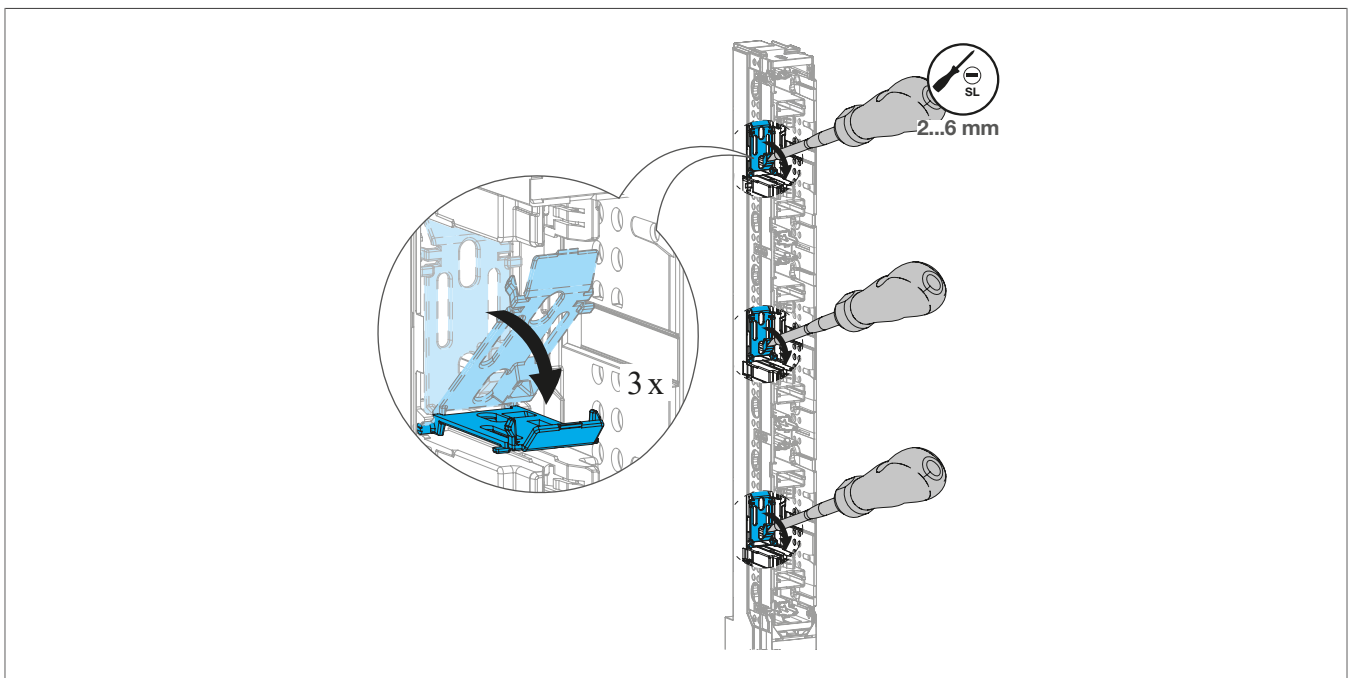

Figure: Opening the cover flaps

Installing the LVZSA microswitch option

- 4 Connect the cables to the microswitch and insert the accessory vertically into the device until the lower stop. The levers must point outwards.

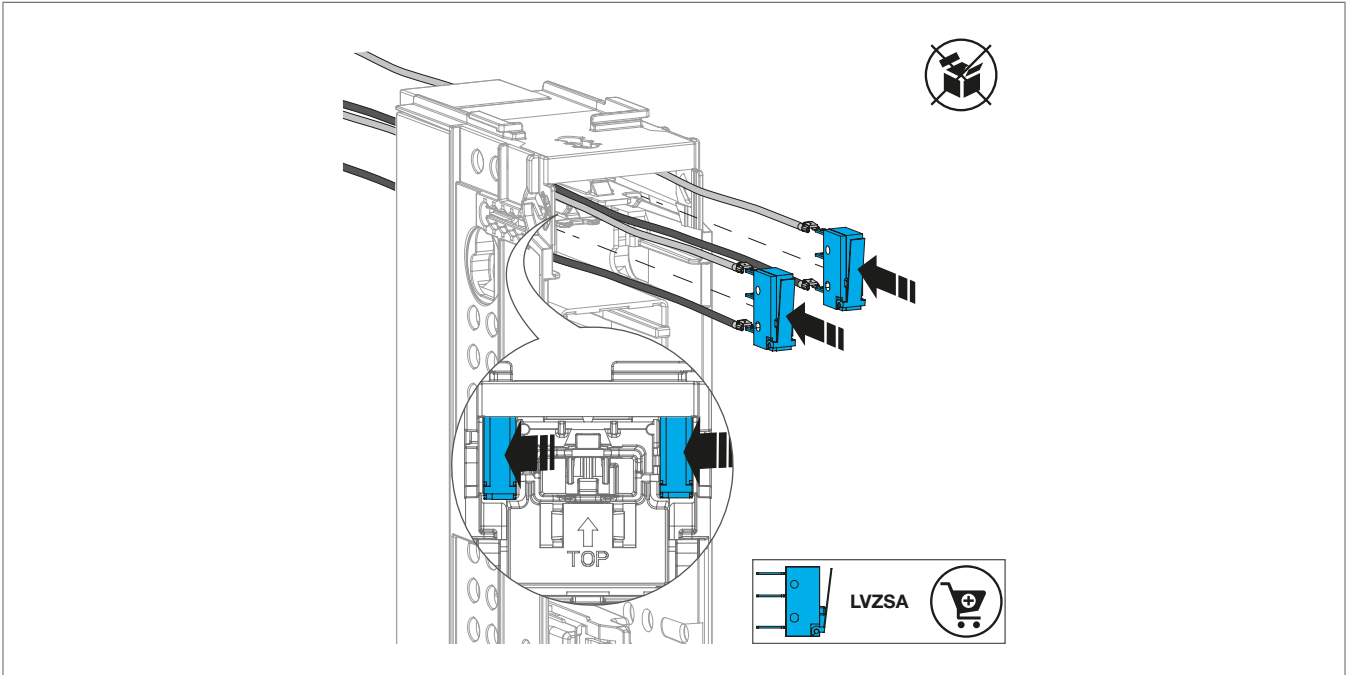

Figure: Installing the microswitch

5.2 Installation with M8 screws

- 1 Align the device with the busbars (see figure, A).
- 2 Insert the screws through the fuse switch cage and the holes in the fuse switch base into the dedicated screwholes of the busbars (see figure, B).
- 3 Tighten the screws evenly and completely.

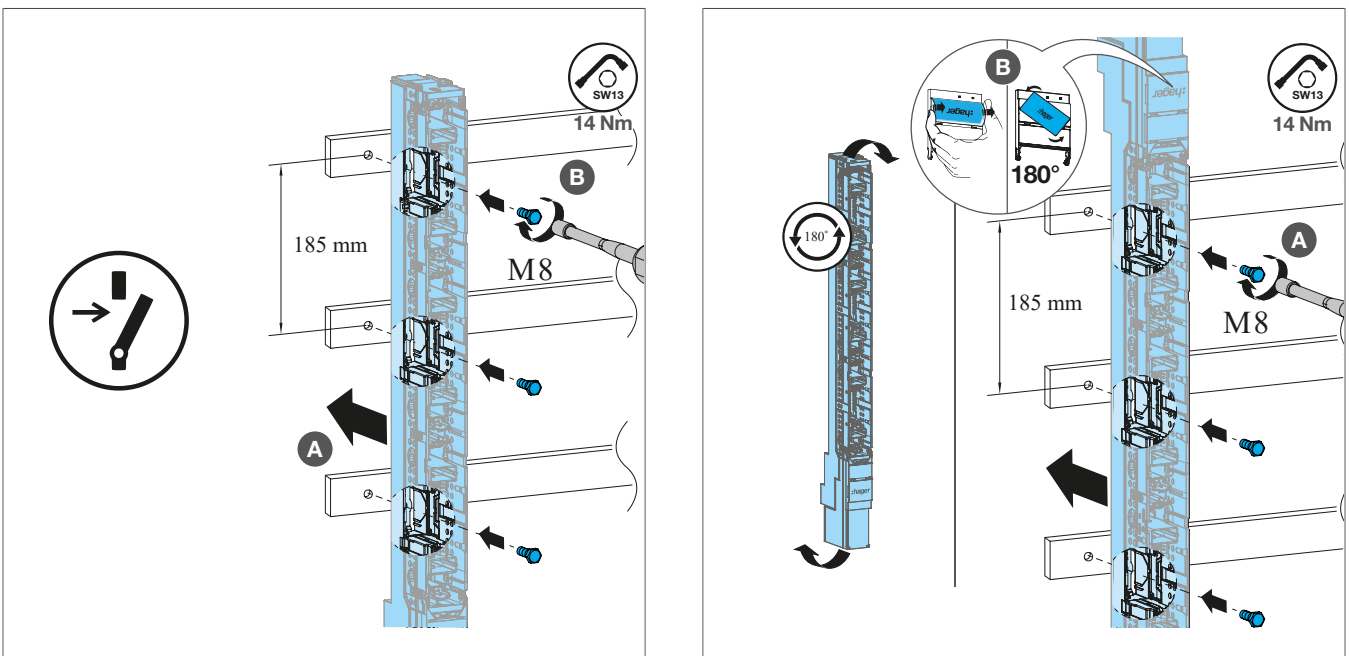

Figure: Tightening of the M8 screws (right shows 180° rotated)



Mounting orientation rotated by 180°

Alternatively, the fuse switch disconnecter can be installed rotated 180°. In this case, rotate the device and follow the same steps. Support the device from below. The nameplate can also be rotated.

5.3 Installation using hooks

Use the LV8Z00EK accessory for installation using hooks.

- 1 Align the device with the busbars (see figure, A)
- 2 Slide the hooks into the rails in the interior of the device base until the stop (see figure, B).
 - For 40 mm busbars use the upper rail.
 - For 30 mm busbars use the lower rail.
- 3 Tighten the screws of the hooks (see figure, C).

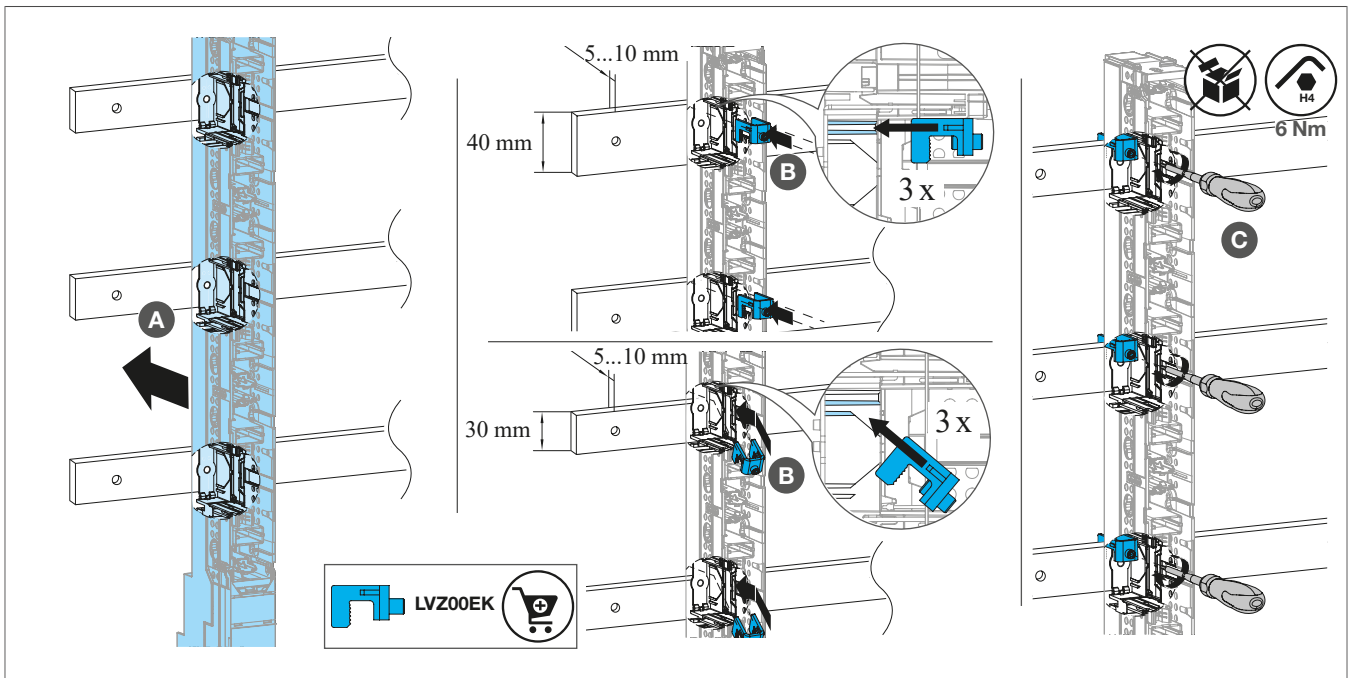

Figure: Installation using hooks



Mounting orientation rotated by 180°

Rotate the device 180°. Then Follow the steps as described before.

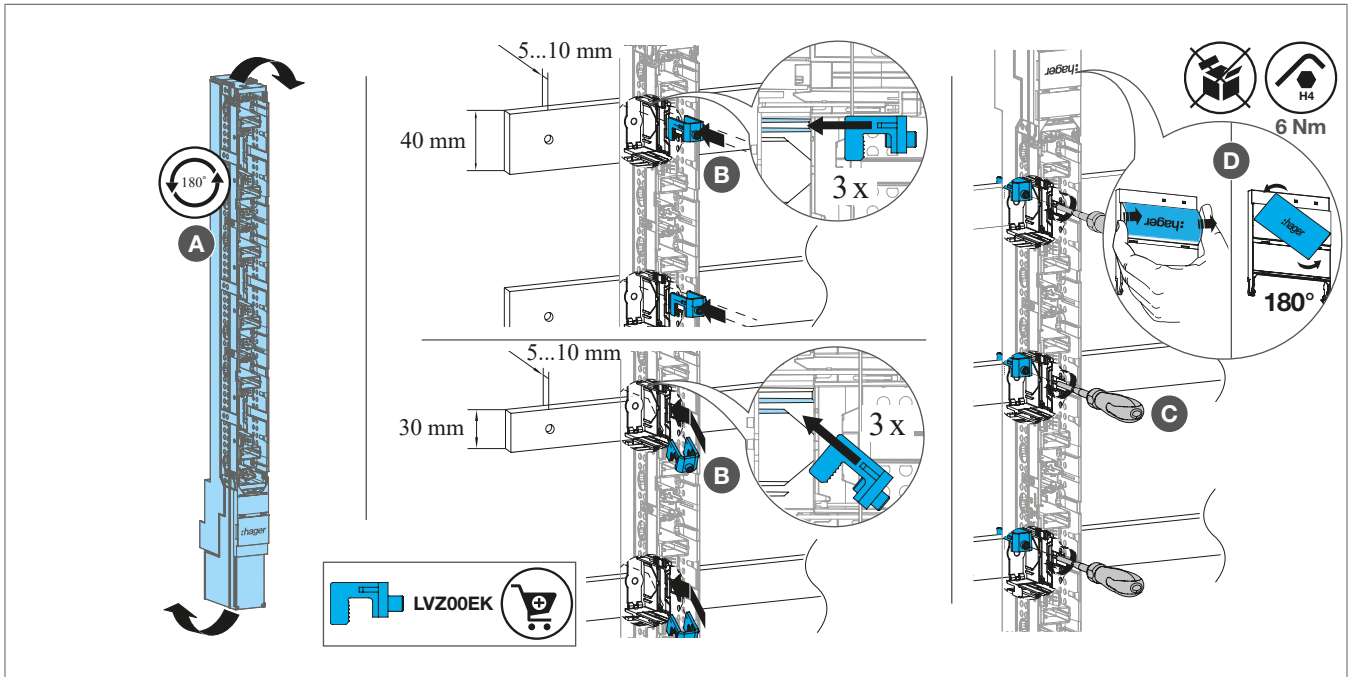

Figure: Installation using hooks, rotated 180°

5.4 Installation of the IP2X-system devices

- The devices LV8SG00PSTE and LV8SG00PSTP can only be mounted with hooks.
- Use the lower rails for the hooks (refer to step 2 of chapter 'Installation using hooks').
- Rotating by 180° is not possible.

5.5 Completing installation

- 1 Secure the window by fastening with 3 mm self-tapping screws (one piece per window).

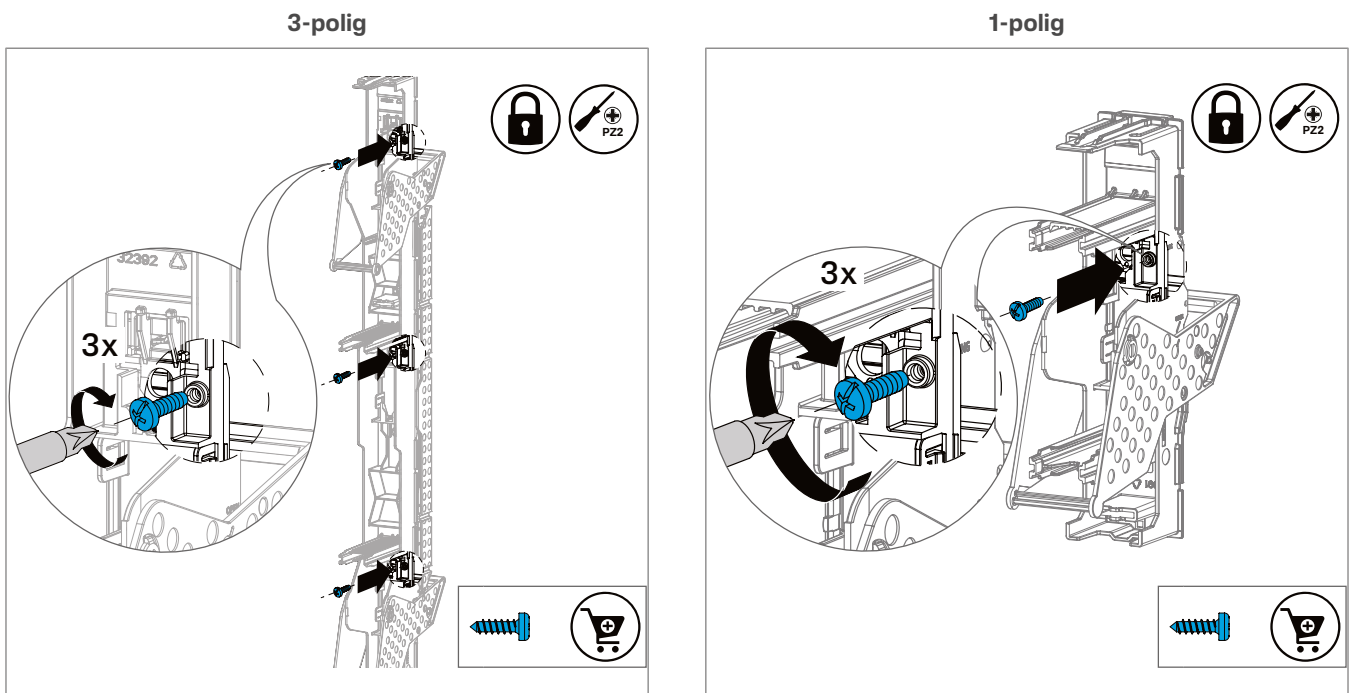

Figure: Securing the window

Inserting and closing the fuse switch lid

- 1 With the handle in **open** position, Insert the fuse switch lid (1) at the appropriate mounting slots of the fuse switch cage.
A clicking sound and noticeable locking confirm the correct seating.
- 2 Close the lid by folding back the handle until it clicks into place.

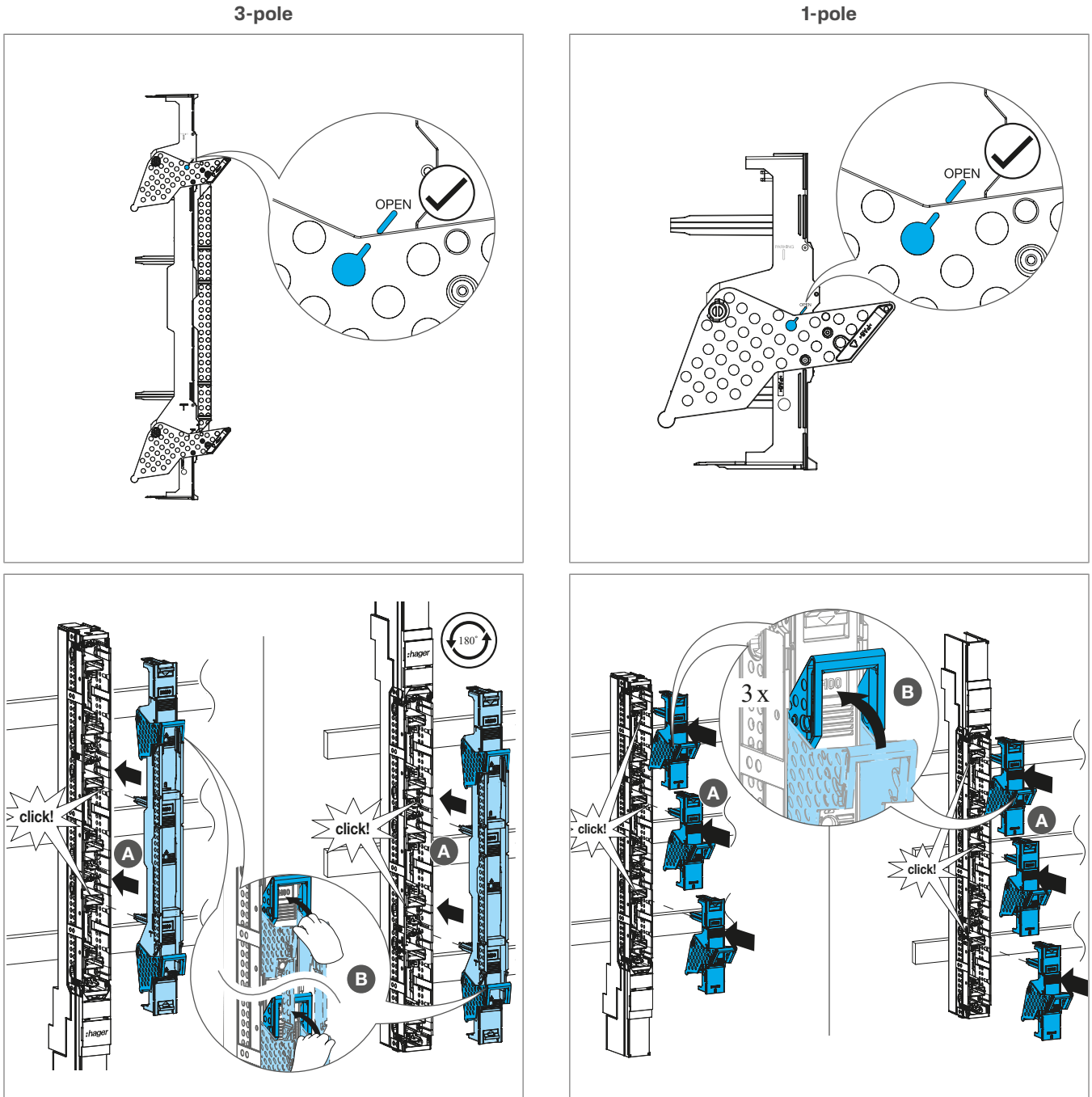

Figure: Inserting and closing the fuse switch lid



Mounting orientation rotated by 180°

The fuse switch lid always fits in in the upright position.

5.6 Installation of the touch protection cover and the blanking cover

Securing the touch protection cover using angle brackets

- 1 Insert the LVZAW (angle bracket) accessory and turn it 90° **anti-clockwise**.
- 2 Secure the touch protection cover with M6 screws.

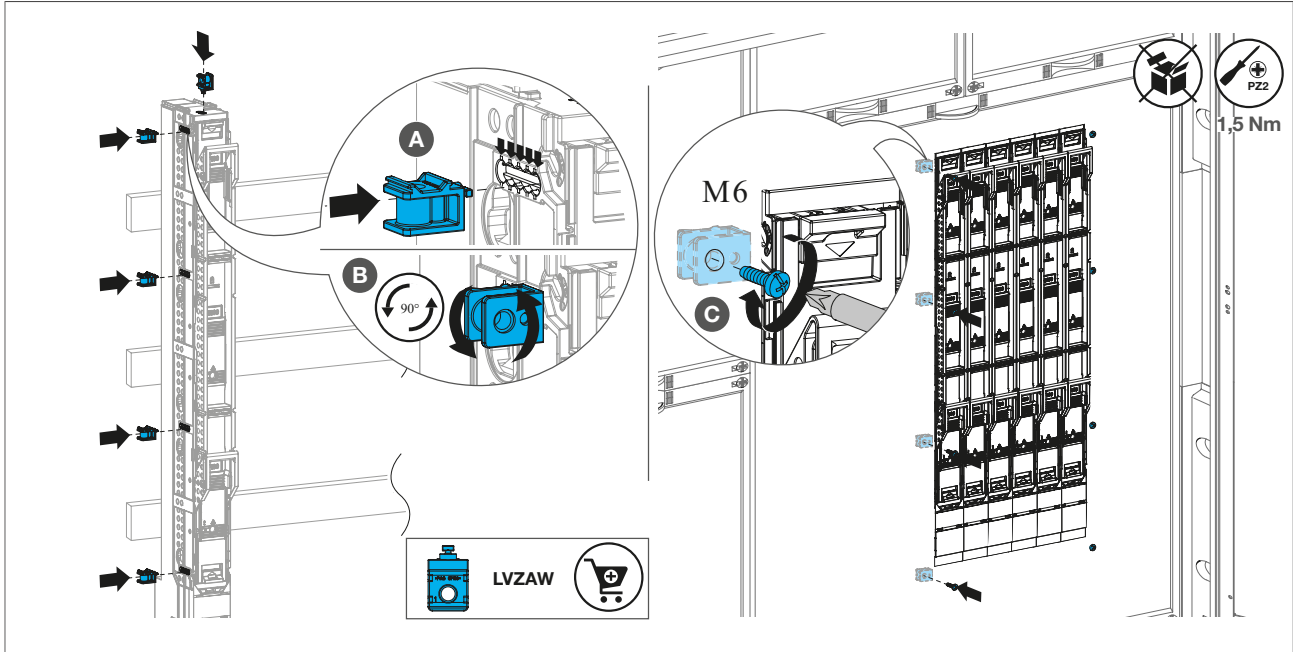

Figure: Securing the cover using angle brackets

Mounting the sideframe

- 1 Insert the LVZAW (angle bracket) accessory and turn it 90° **clockwise**.
- 2 Clip on the LVZPB (sideframe) accessory.

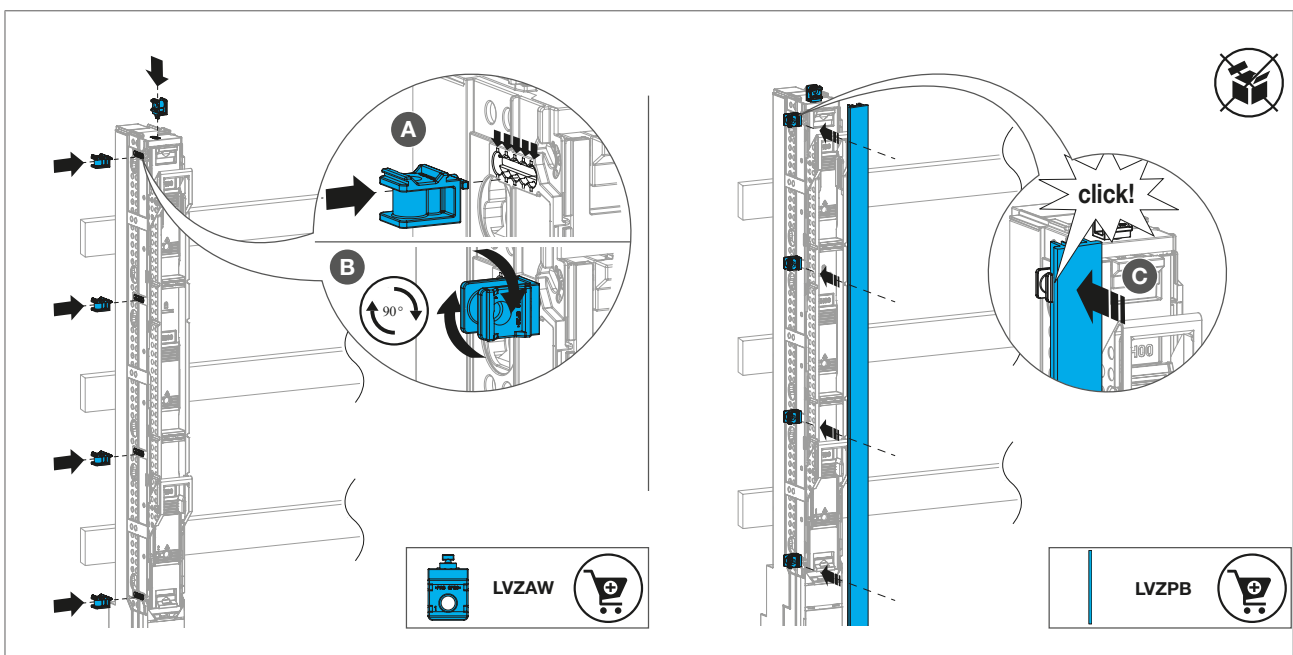

Figure: Mounting the sideframe

6 Electrical connection



Danger

Electric shock when live parts are touched!

An electric shock can lead to death!

- Before working on the device, disconnect the power supply. Consider all circuits that could supply the device with dangerous voltages.
- Lock the switching devices in the disconnect position.
- Use a suitable measuring device to check that the device is volt-free.
- During maintenance work, set up safety barriers and attach a hazard sign.
- It is essential to wear appropriate personal protective equipment (PPE) when working on live equipment.



Danger

Risk of fire due to loose cables

Cables that are not sufficiently secured can heat up during operation and cause arcing

- Use only permitted cable types with the corresponding cross section
- Strip the conductor ends to the specified length and screw them to the specified tightening torque.

The terminal connections and permissible conductor cross-sections are specified on the terminal marking and in the technical documentation.

The specified tightening torques and conductor types (solid, flexible, with conductor sleeves) must be observed.







					re 	rm 	se 	sm 
M8 screws	M8	14 Nm	Cu/Al	1 x 70 ... 95 mm ²				
Cage terminals	M5	5 Nm	Cu			2.5 ... 95 mm ²		
LVZ00C	2 x M5	4 Nm	Cu		1.5 ... 95 mm ²			
LVZ00A	2 x M5	4 Nm	Cu/Al			1.5 ... 95 mm ²		
LVZ001A	2 x M5	4 Nm	Cu/Al			70 ... 150 mm ²		
LVZASD	2 x M8	14 Nm	Cu/Al	2 x 35 mm ²				

Table 1: Conductor cross-sections and tightening torques

Connecting the cables

- 1 Using a slotted screwdriver, take out the terminal cover (3) and pull it off the side guides. Do not tilt while doing so.

Electrical connection

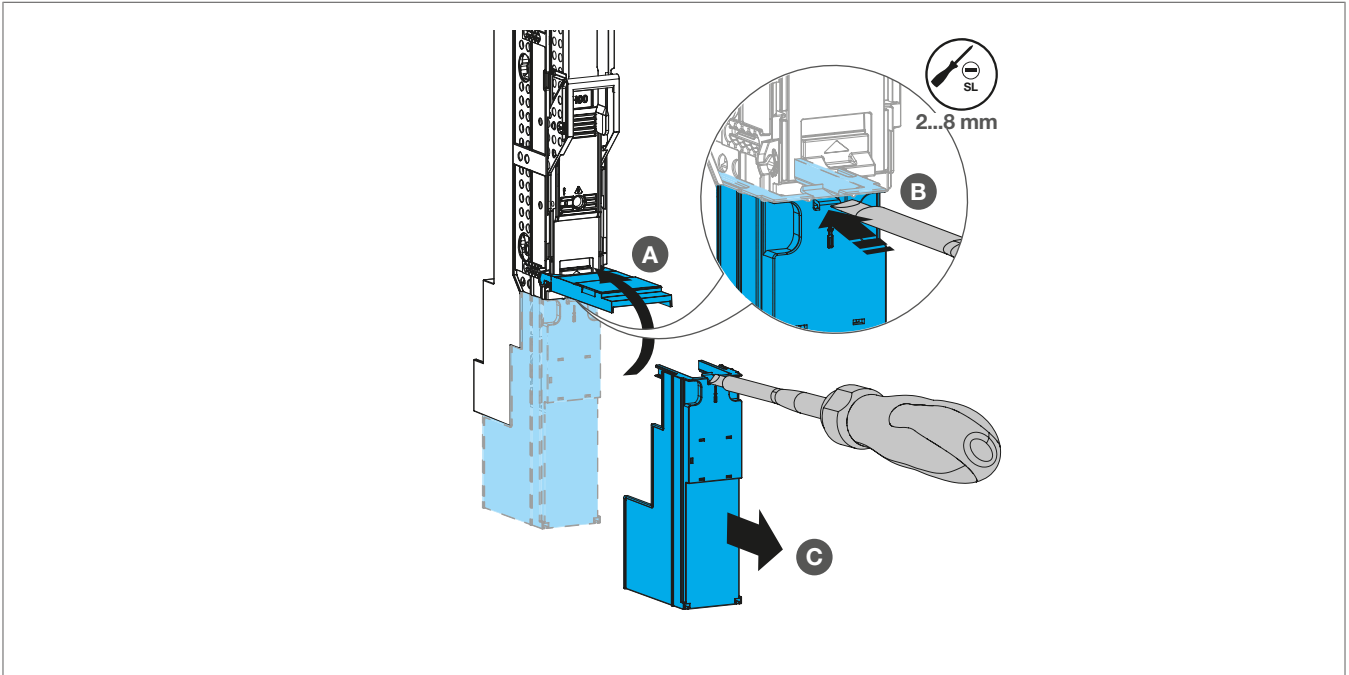
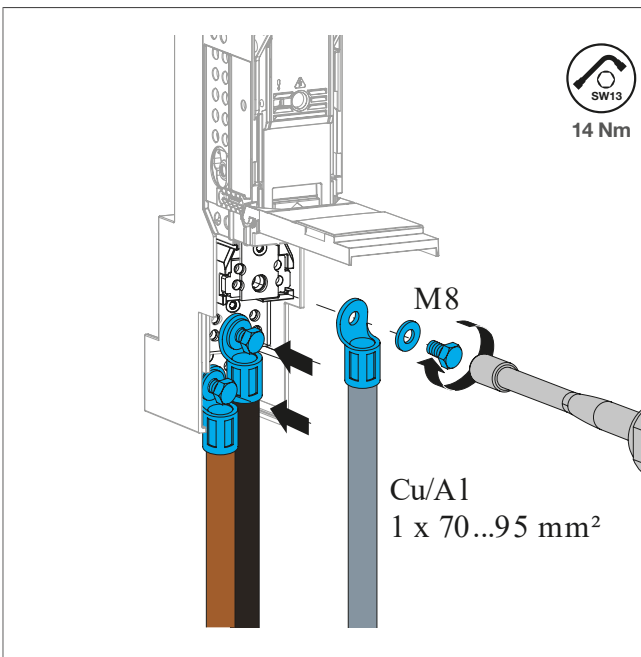
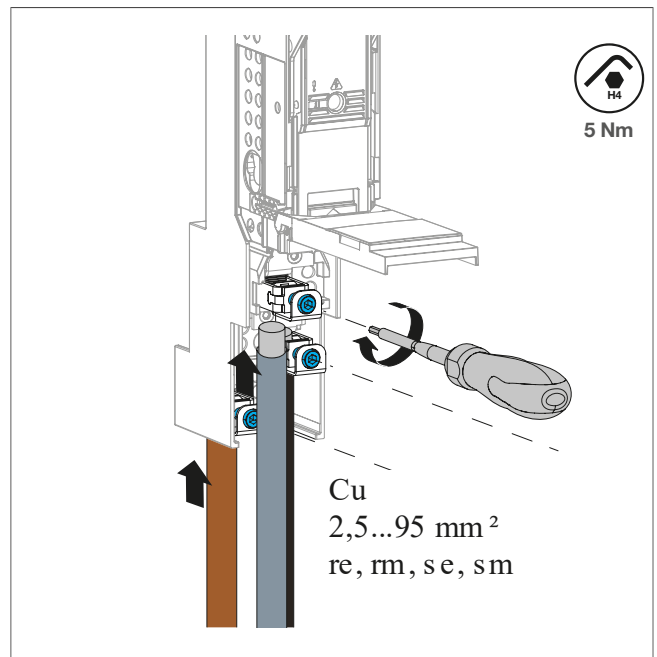

Figure: Open the connection compartment

Following scenarios are possible for connecting the cables to the fuse switch disconnecter.



Connection with standard M8 screws and cable lugs



Connection with cage clamps

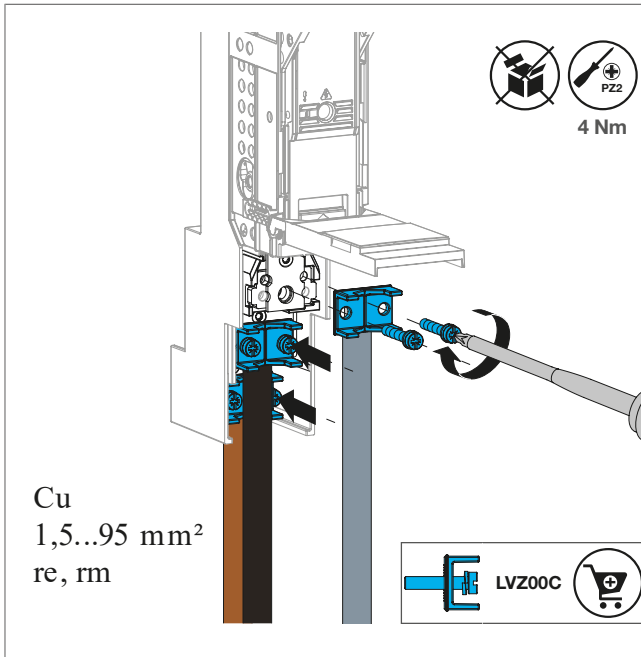

Connection with LVZ00C terminal adapter (accessory)

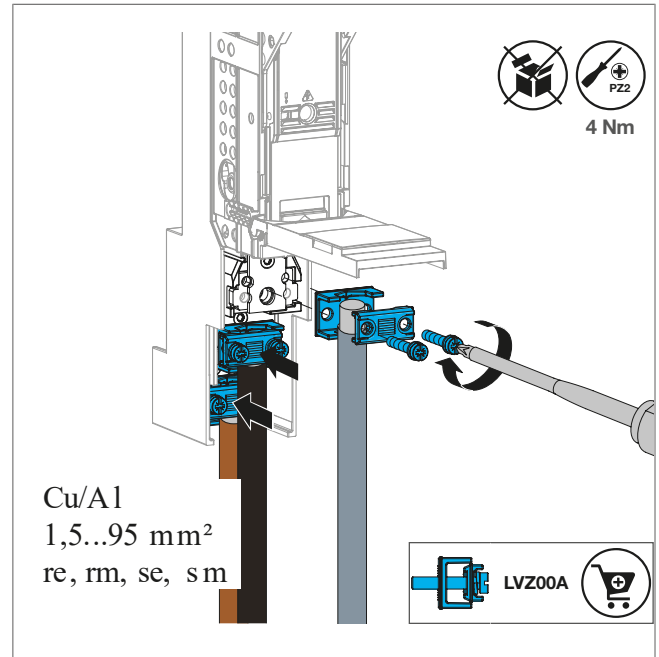

Connection with LVZ00A terminal adapter (accessory)

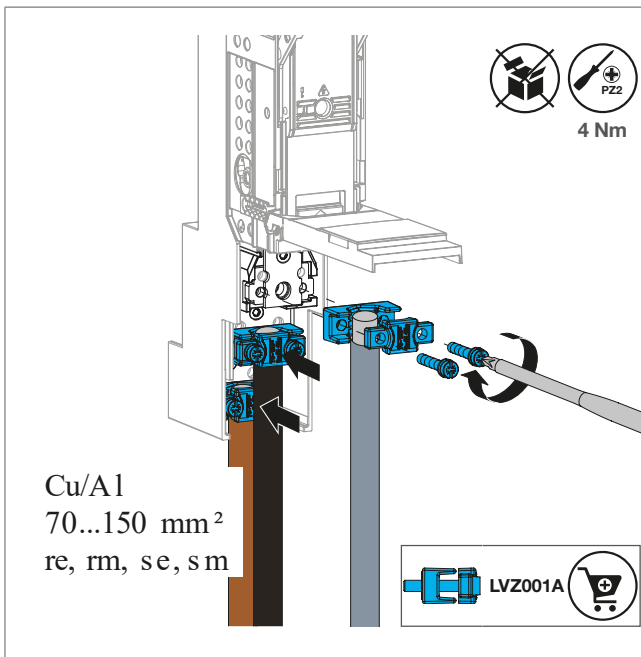

Connection with LVZ001A terminal adapter (accessory)

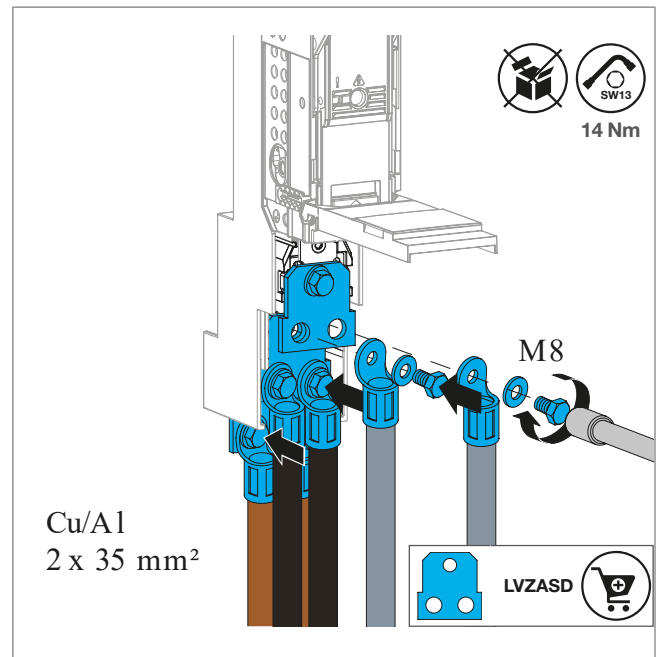

Connection with LVZASD terminal adapter (accessory)

7 Fuse links

7.1 Inserting and removing fuse links



Danger

Electric shock when live parts are touched!

An electric shock can lead to death!

- Before working on the device, disconnect the power supply. Consider all circuits that could supply the device with dangerous voltages.
- Lock the switching devices in the disconnect position.
- Use a suitable measuring device to check that the device is volt-free.
- During maintenance work, set up safety barriers and attach a hazard sign.
- It is essential to wear appropriate personal protective equipment (PPE) when working on live equipment.

Inserting the fuse links

- Insert the fuse links into the fuse link holders until they click into place.

3-pole

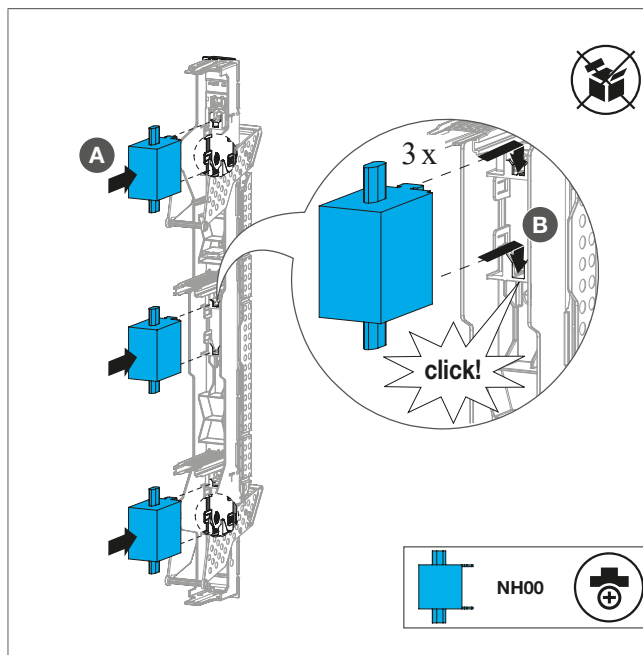

1-pole

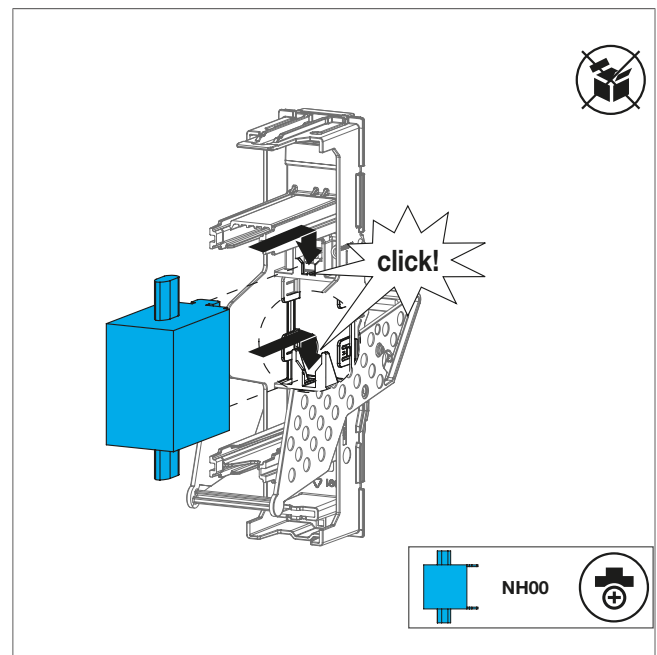

Figure: Inserting fuse links

Removing the fuse links



Caution

Burns caused by heated fuse links!

During operation of the device, the fuse links can heat up significantly and cause burns.

- After removing the fuse links don't touch them until they have cooled down.

- Release and remove the fuse links by pressing the blue fuse link release button.

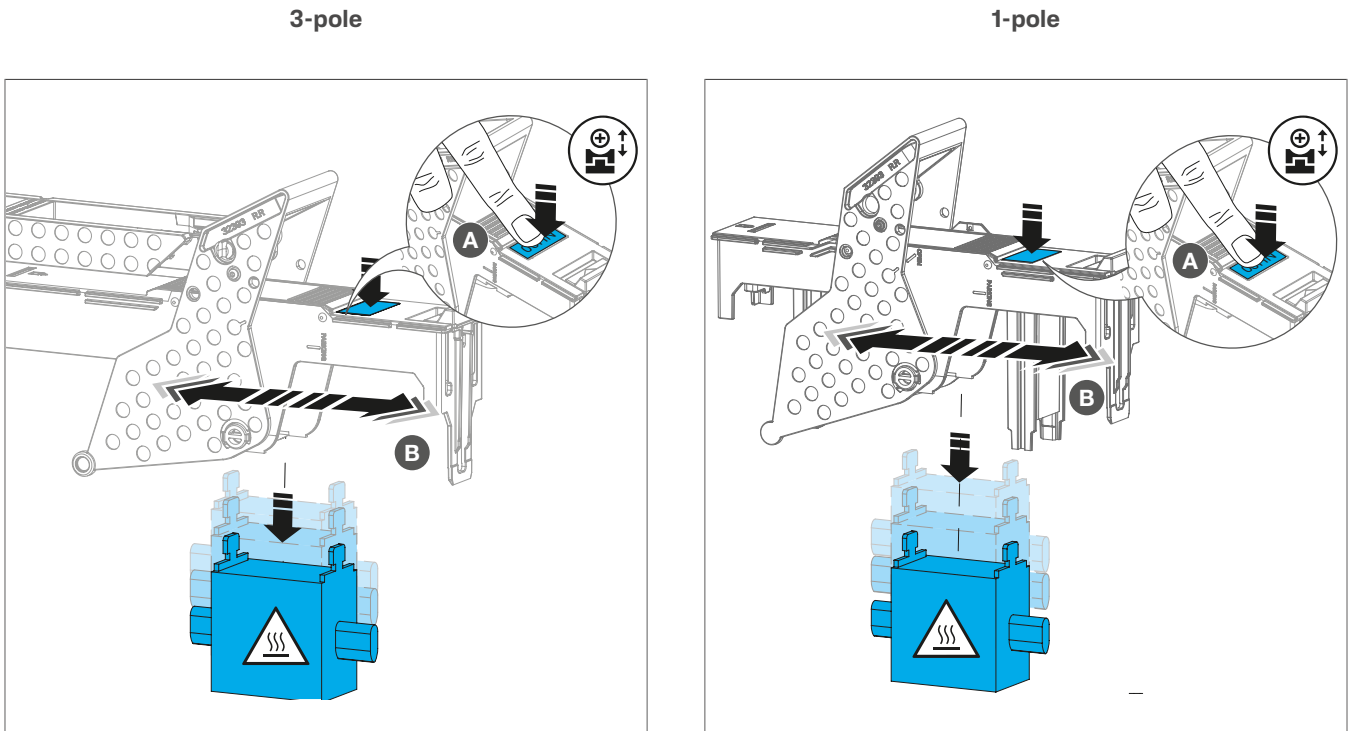

Figure: Removing fuse links

7.2 Fuse monitoring and testing

Testing fuse monitoring (FM test)

This function is only applicable for the product variant with integrated fuse monitoring (11).

► For more information, see [\(Electronic fuse monitoring system\)](#).

- ☑ The fuse switch disconnecter is mounted and connected.
- ☑ The fuse switch lid (1) is securely locked.

- Test correct functioning of the fuse monitoring by pressing the test button located on the front top of the module.

During the test phase all LEDs will blink in red and the NO/NC state are switched.

After some seconds the LEDs return to steady green and the NO/NC return to normal state.

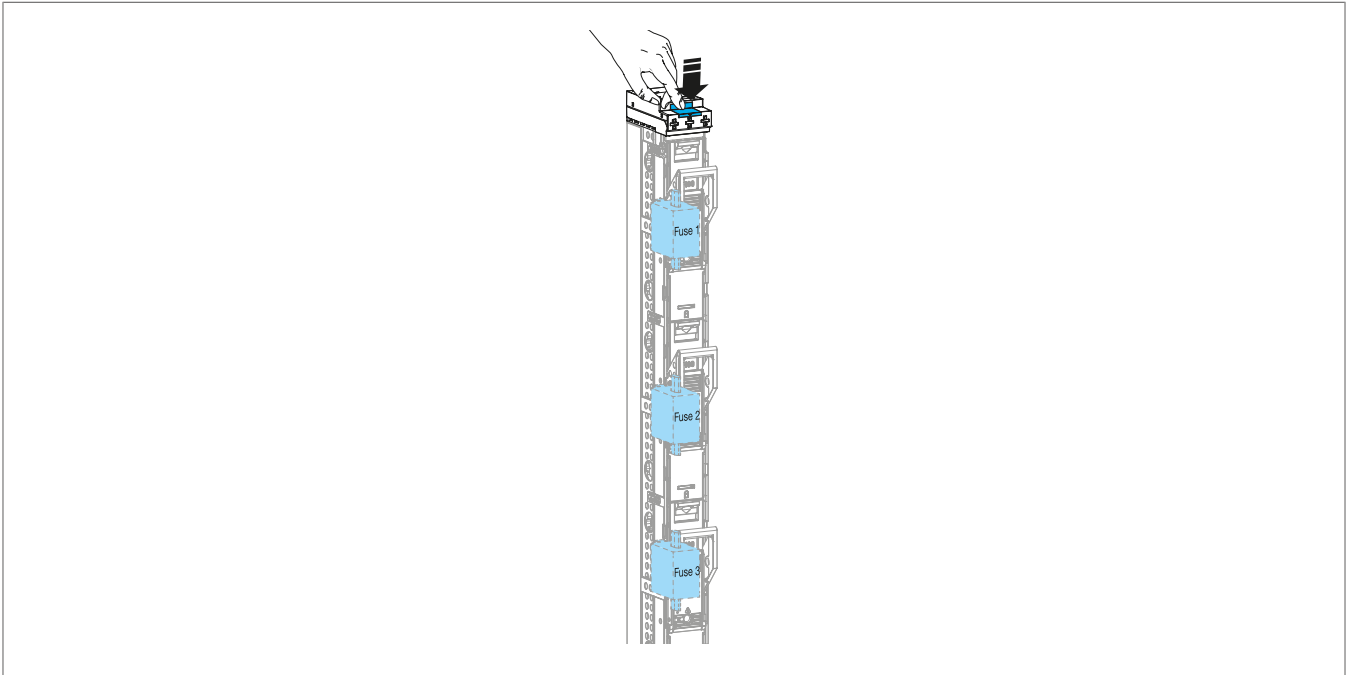

Figure: Fuse monitoring test button

Checking the control LED

The fuse monitoring provides information about the condition of each fuse link by the status of its control LED:

- A steady green light indicates that the fuse link is OK.
- Red blinking indicates that the associated fuse link has tripped or no fuse link is installed in the respective phase.
- If the LED is off there is an error. Refer to chapter [\(Electronic fuse monitoring system\)](#).

Examples

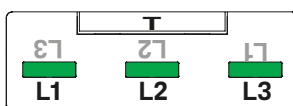

All fuse links are ok.

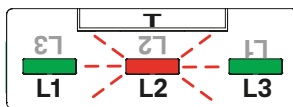

Fuse links of L1 and L3 are ok.
 Fuse link of L2 has tripped.

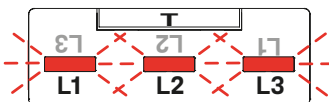

All three fuse links have tripped.

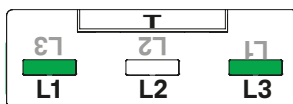

Fuse links in L1 and L3 are ok.
 Error on fuse link for L2 (refer to chapter 10).

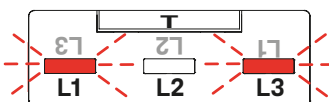

Fuse links for L1 and L3 have tripped.
 Error on fuse link for L2 (refer to chapter 10).

8 Completing the installation

8.1 Sealing

- ① Insert the sealing wire through the corresponding openings on the handle (three times for the 1-pole).
- ② Fasten the seal using an approved sealing tool.
- ③ Document the seal number for future traceability.

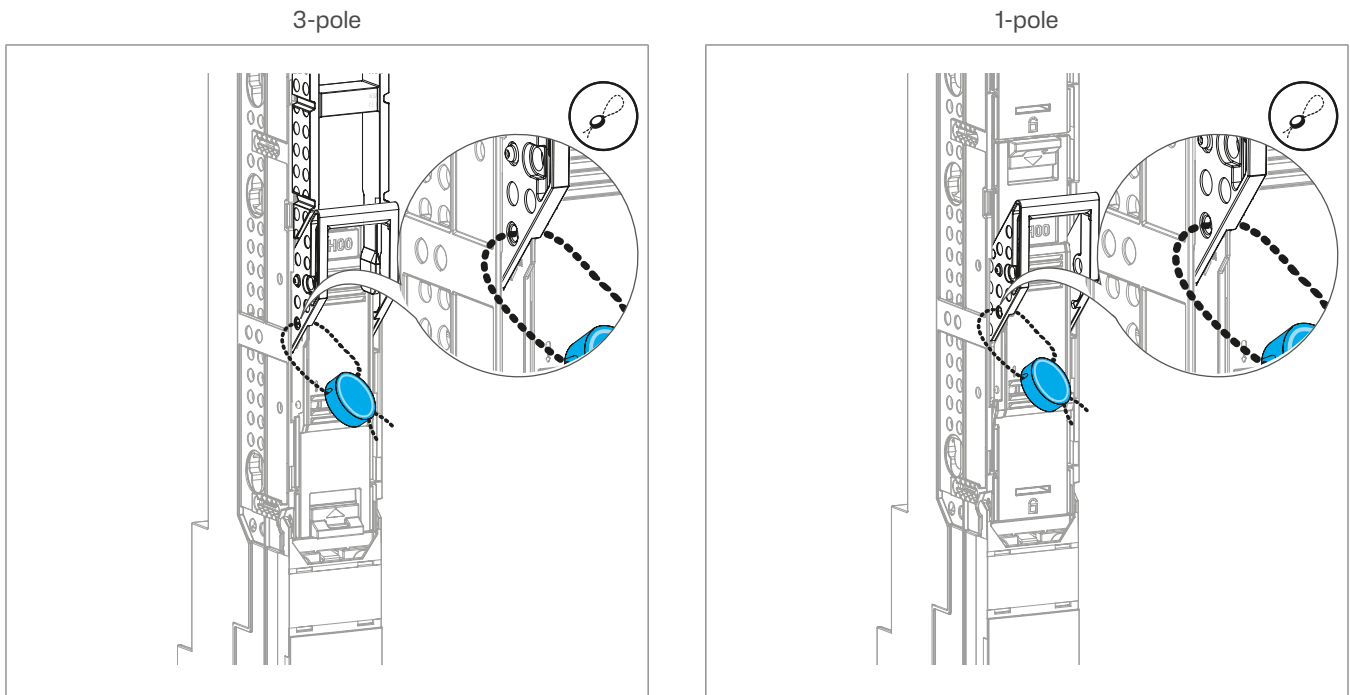

Figure: Sealing

8.2 Labelling

Labelling the nameplate

- ① Fold up the nameplate holder (5).
- ② Pull out the identification paper to the right.
- ③ Add information to the identification paper.
- ④ Reinsert the identification paper.
- ⑤ If necessary, an additional label can be clipped on the nameplate holder.

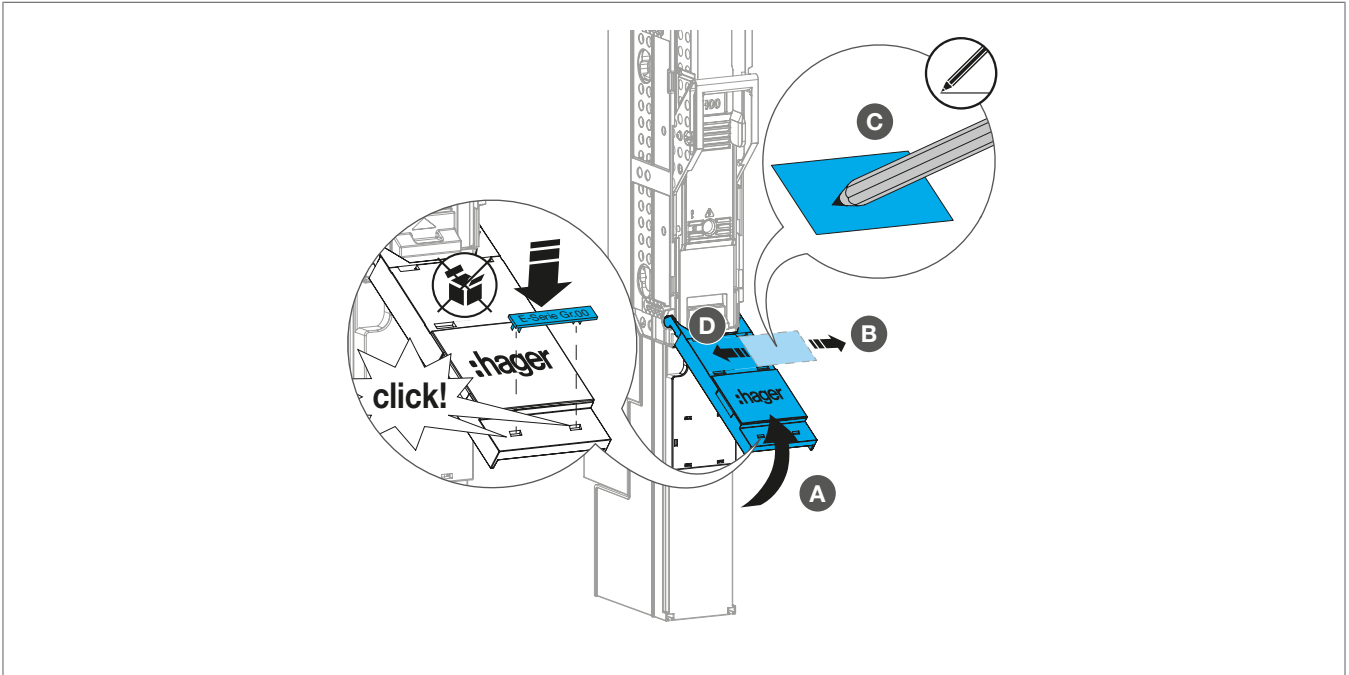

Figure: Labelling the nameplate

Customizing the position of the nameplate holder

The nameplate holder can also be placed on the top of the device.

- 1 Fold up the nameplate holder (5) by 45°.
- 2 Carefully spread both retaining lugs.
- 3 Pull out the nameplate holder.
- 4 Place the nameplate holder on the top of the device by aligning its retaining lugs with the dedicated slots.
- 5 Click the retaining lugs into place.
- 6 Turn the nameplate (6) 180° so that Hager is again legible.

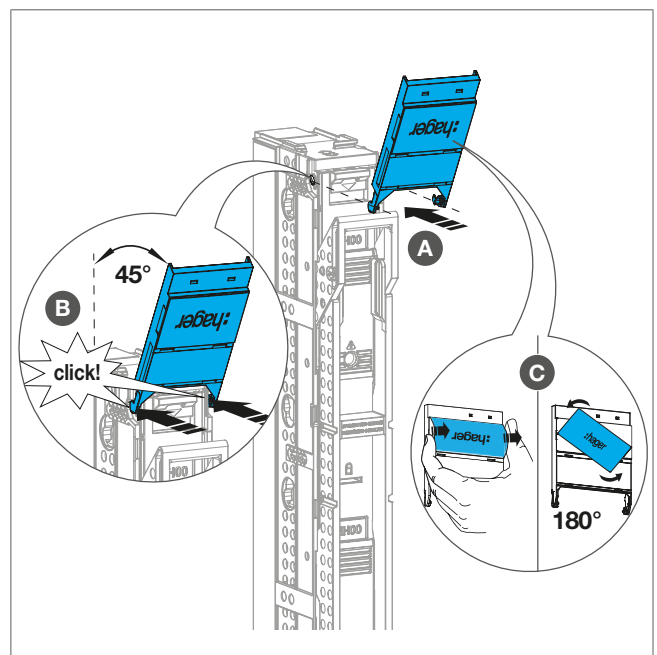
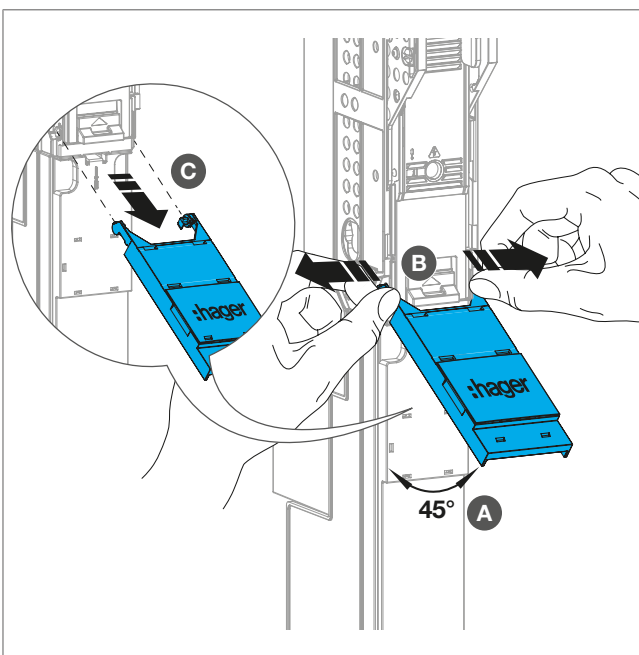

Figure: Customizing the position of the nameplate holder

9 Operation

9.1 Voltage absence test (VAT)

- 1 Use a flat-head screwdriver to gently lift open the sliding window (10) (see figure left, A and B).
- 2 Perform the voltage test through the dedicated opening (see figure right, A).
- 3 Then close the sliding window again (see figure right, B) to ensure the IP3X degree of protection on the front of the device.

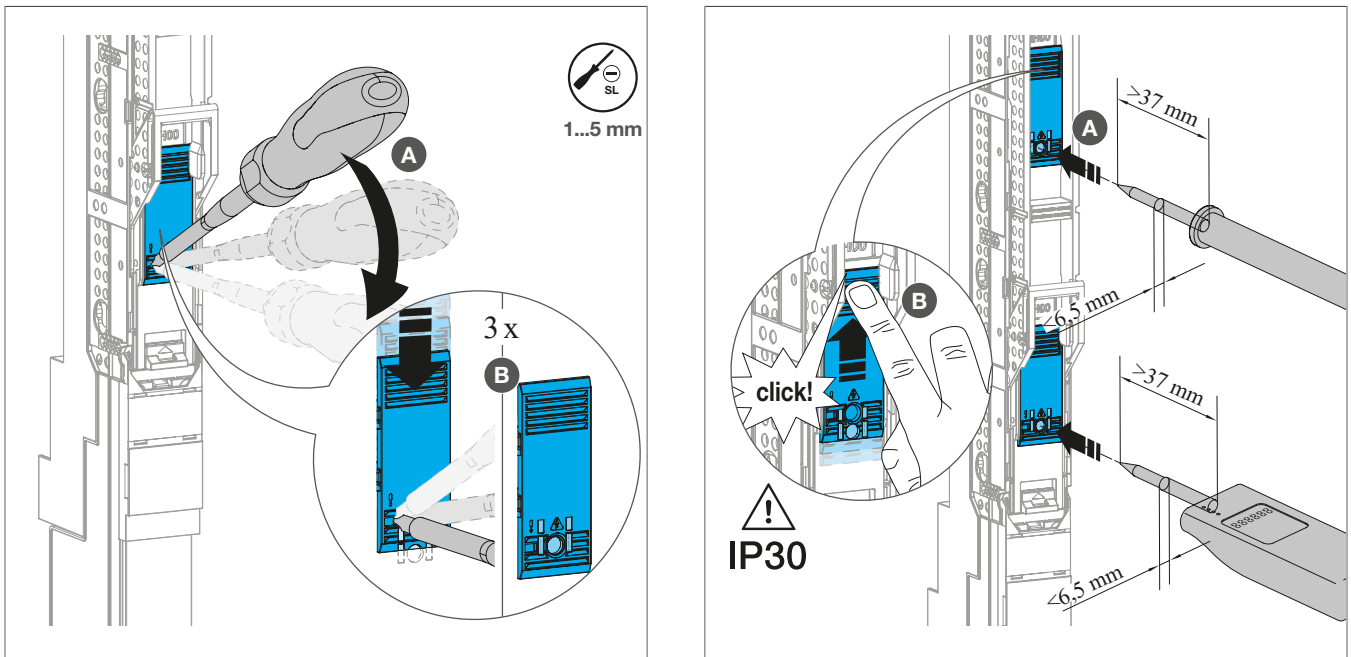

Figure: Voltage absence test (VAT)

9.2 Securing the device in closed position using a padlock

☑ The fuse switch lid is in the closed position.

- 1 Insert the locking piece LV8ZLP into the dedicated slot of the fuse switch lid until it clicks into place. The **Closed** mark is visible.
- 2 Insert a padlock of maximum 8 mm shackle thickness (accessory) into the **Closed** opening of the locking piece.
- 3 Close the padlock.

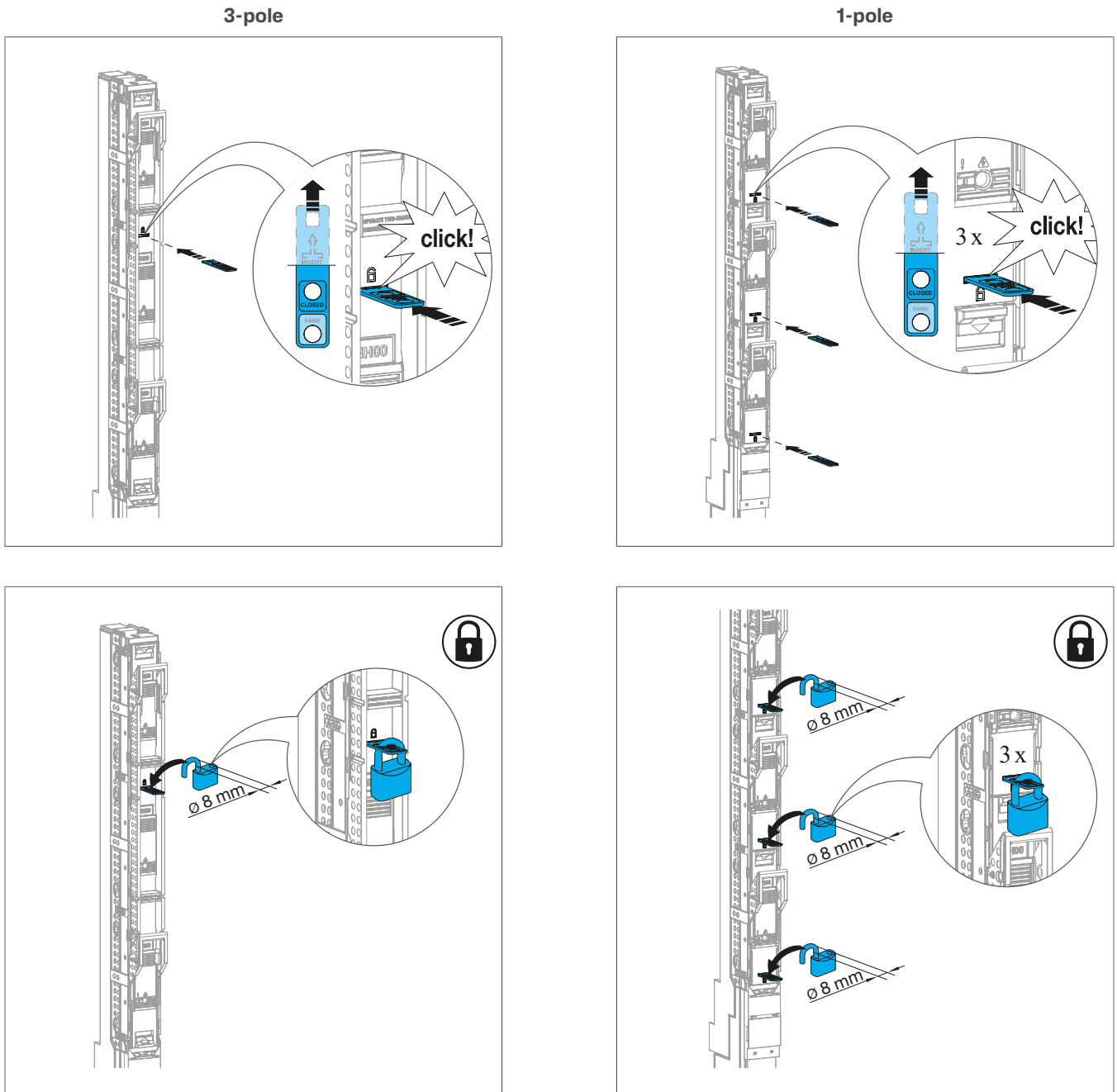

Figure: Securing the device in closed position using a padlock

9.3 Unlocking the device in the closed position

- 1 Open and remove the padlock.
- 2 Pull down the handle to open the fuse switch lid (1). For the 3-pole use both hands.
- 3 Press down the buttons on the fuse switch lid and remove it.
- 4 Pull out the locking piece.

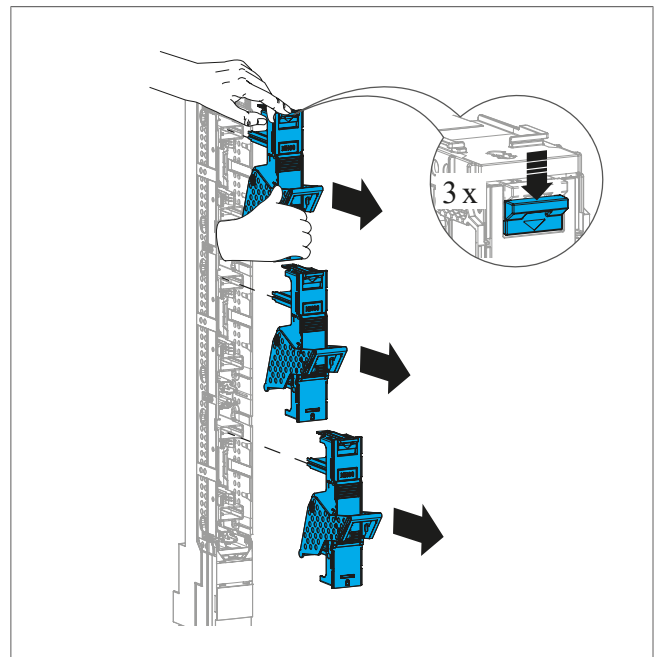
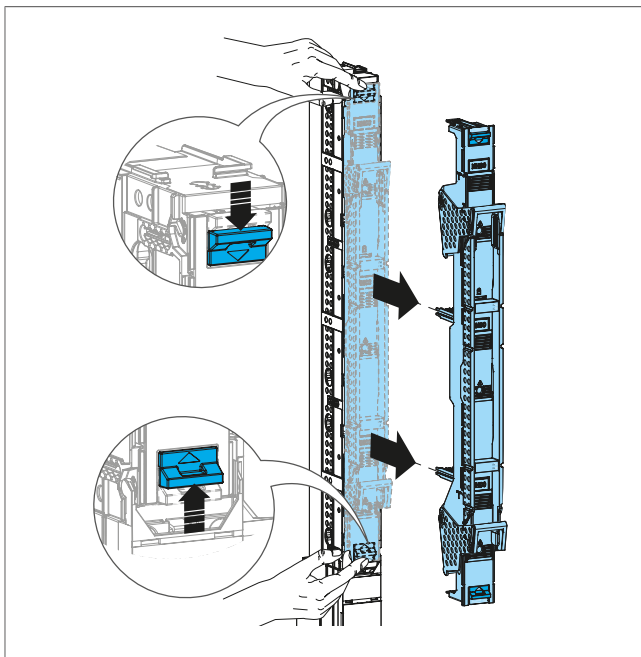
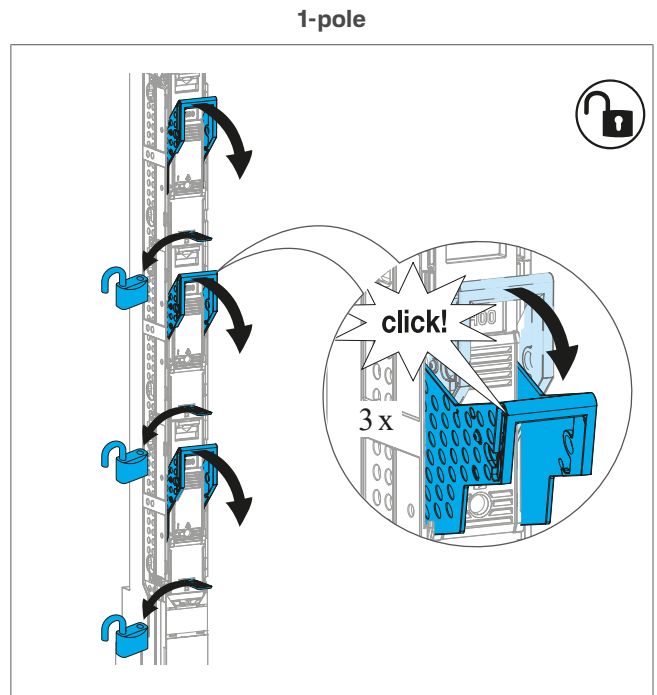
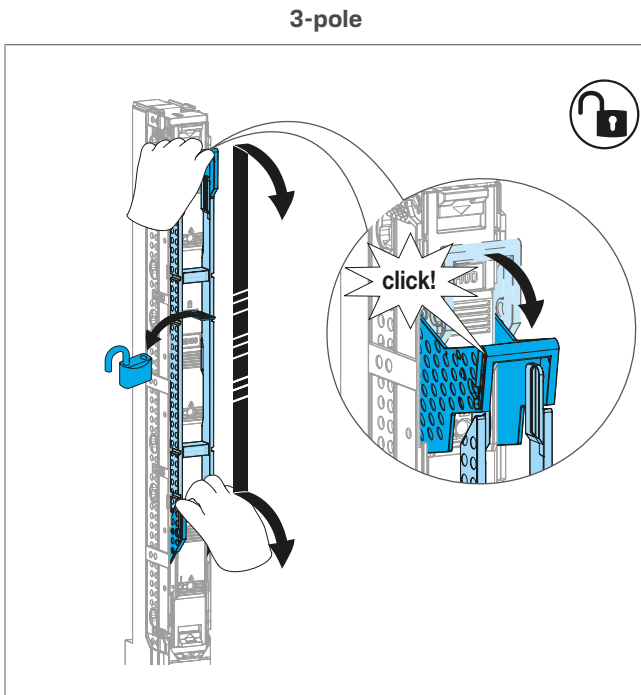

Figure: Unlocking the device in the closed position

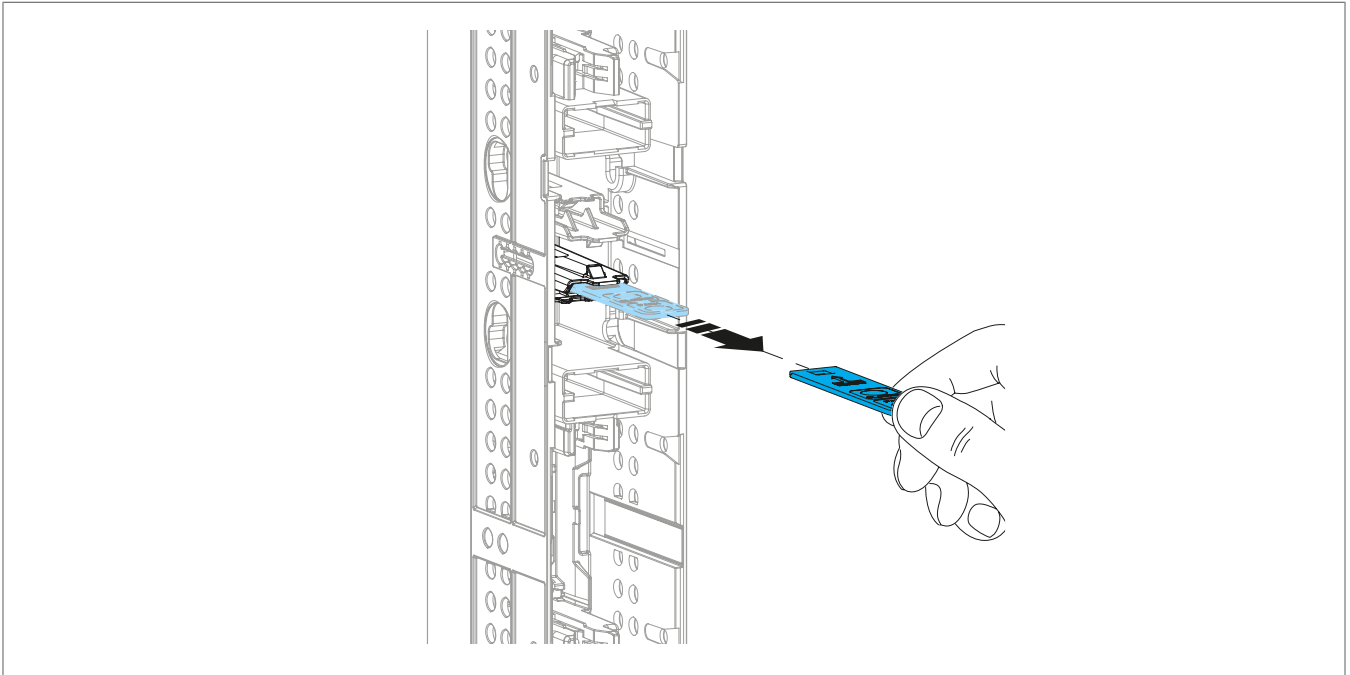

Figure: Unlocking the device in the closed position

9.4 Positioning the device in park position

☑ The device is in closed position.

- ① Pull down the handle to open the fuse switch lid (1). For the 3-pole use both hands.
- ② Press down the buttons on the fuse switch lid and remove it.
- ③ Push the handle up to engage the park position until it clicks into place (see figure, indicator **Parking** in the handle)
- ④ Rotate the fuse switch lid (front side facing inwards) and insert it into the fuse switch cage.
The device is in parking position.

3-pole

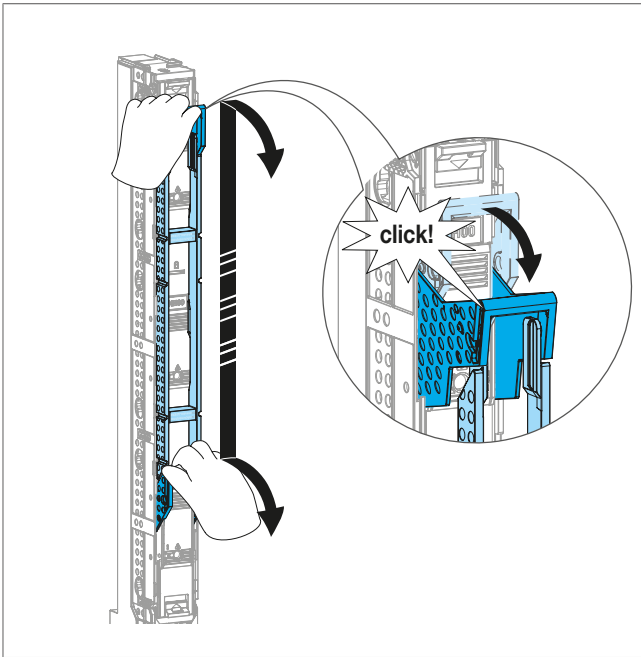

1-pole

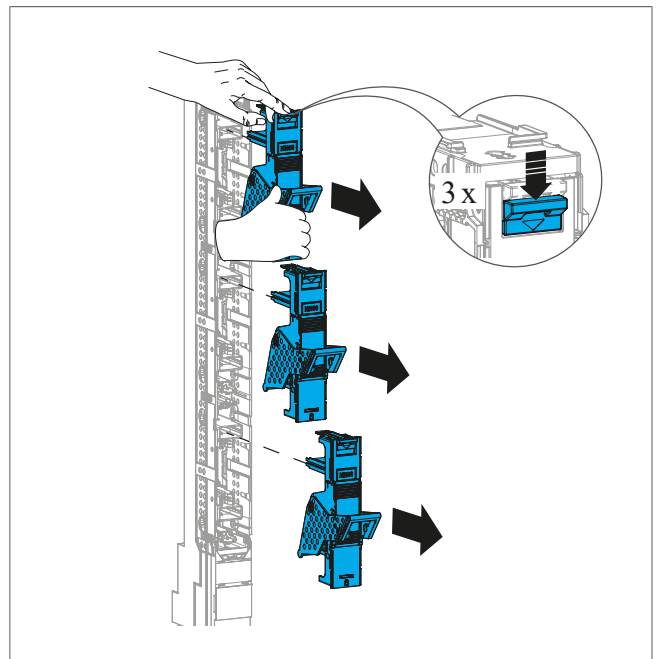
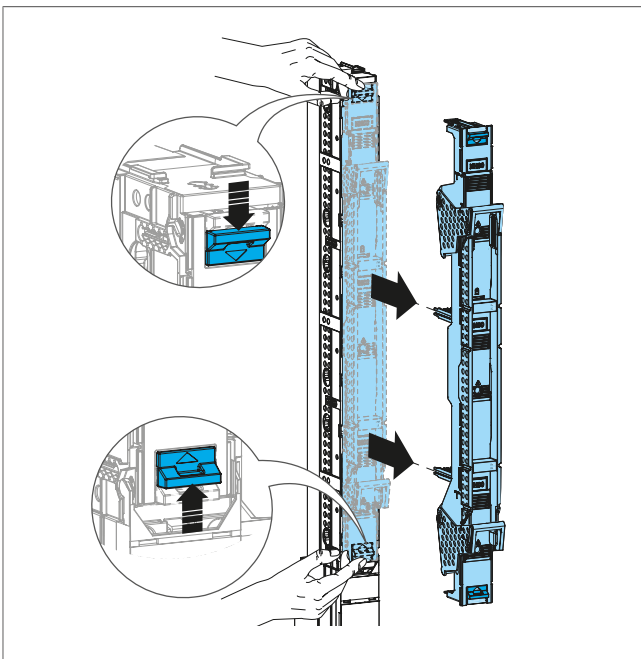
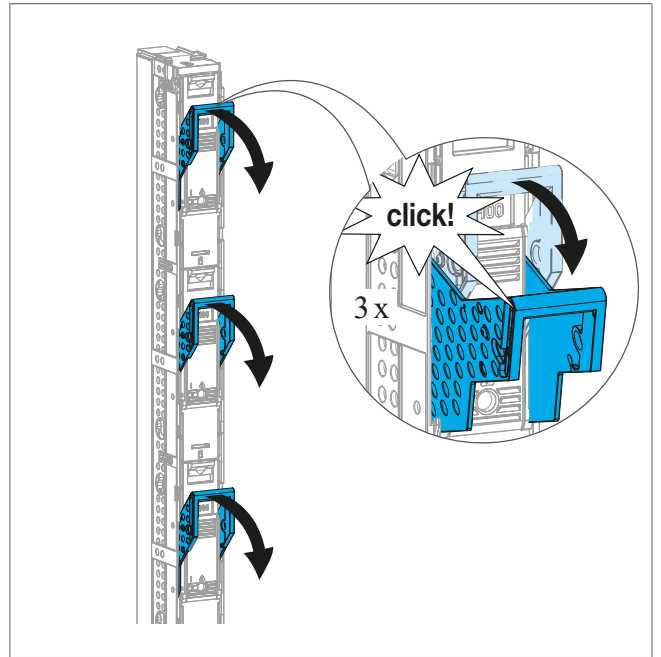

Figure: Positioning the device in park position

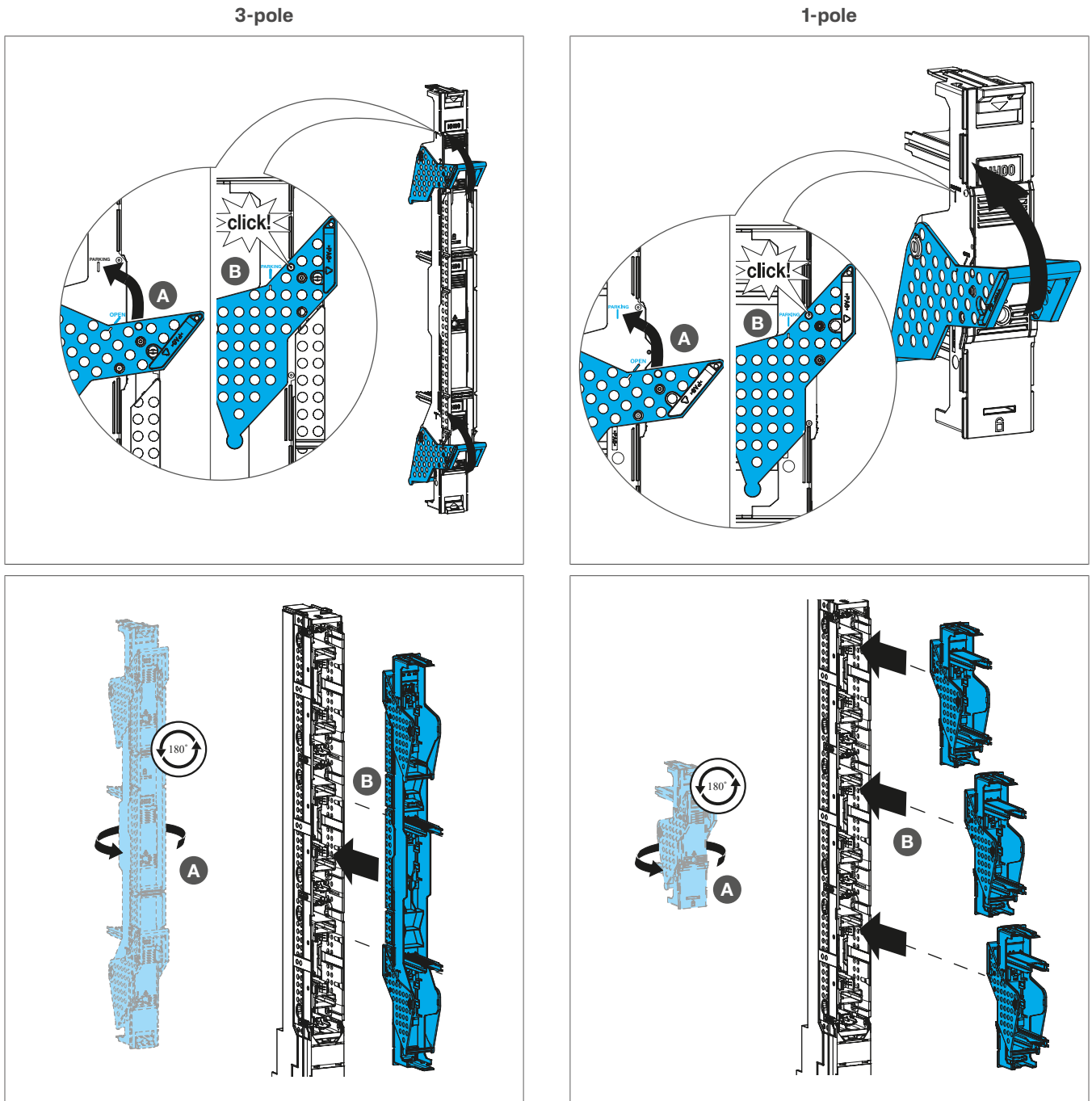

Figure: Positioning the device in park position

9.5 Securing the device in park position using a padlock

☑ The fuse switch lid is in the parking position.

- ① Fully insert the locking piece LV8ZLP into the dedicated slot of the fuse switch lid until it clicks into place.
- ② Insert a padlock of maximum 8 mm shackle thickness (accessory) into the **Park** opening of the locking piece.
- ③ Close the padlock.

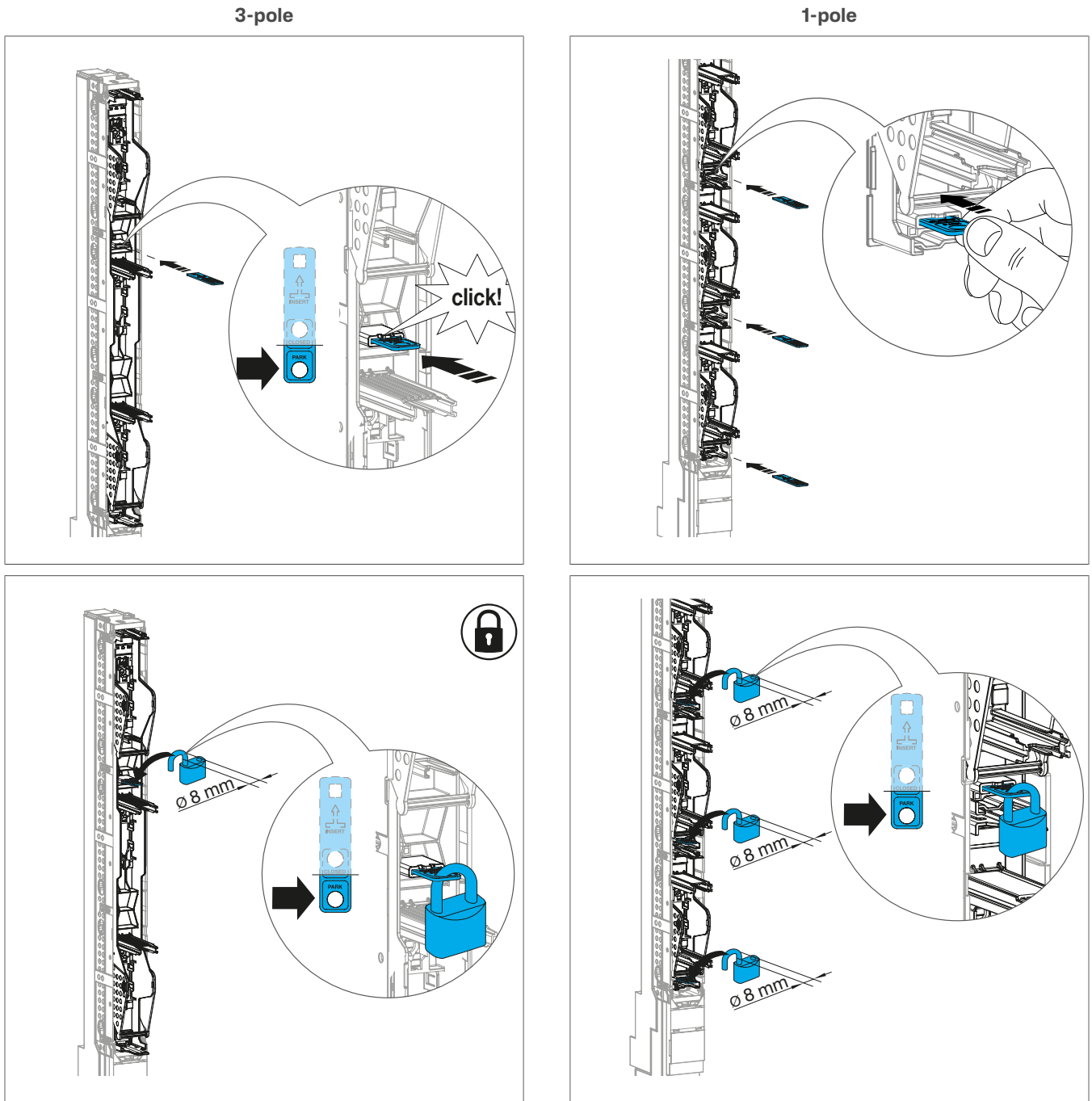

Figure: Securing the device in park position using a padlock

9.6 Unlocking the device in the park position

- 1 Open and remove the padlock.
- 2 Remove the fuse switch lid (1) from the fuse switch cage (2).
- 3 Pull the locking piece LV8ZLP out.



In some cases, the sealing or locking piece is pulled out together with the cover.

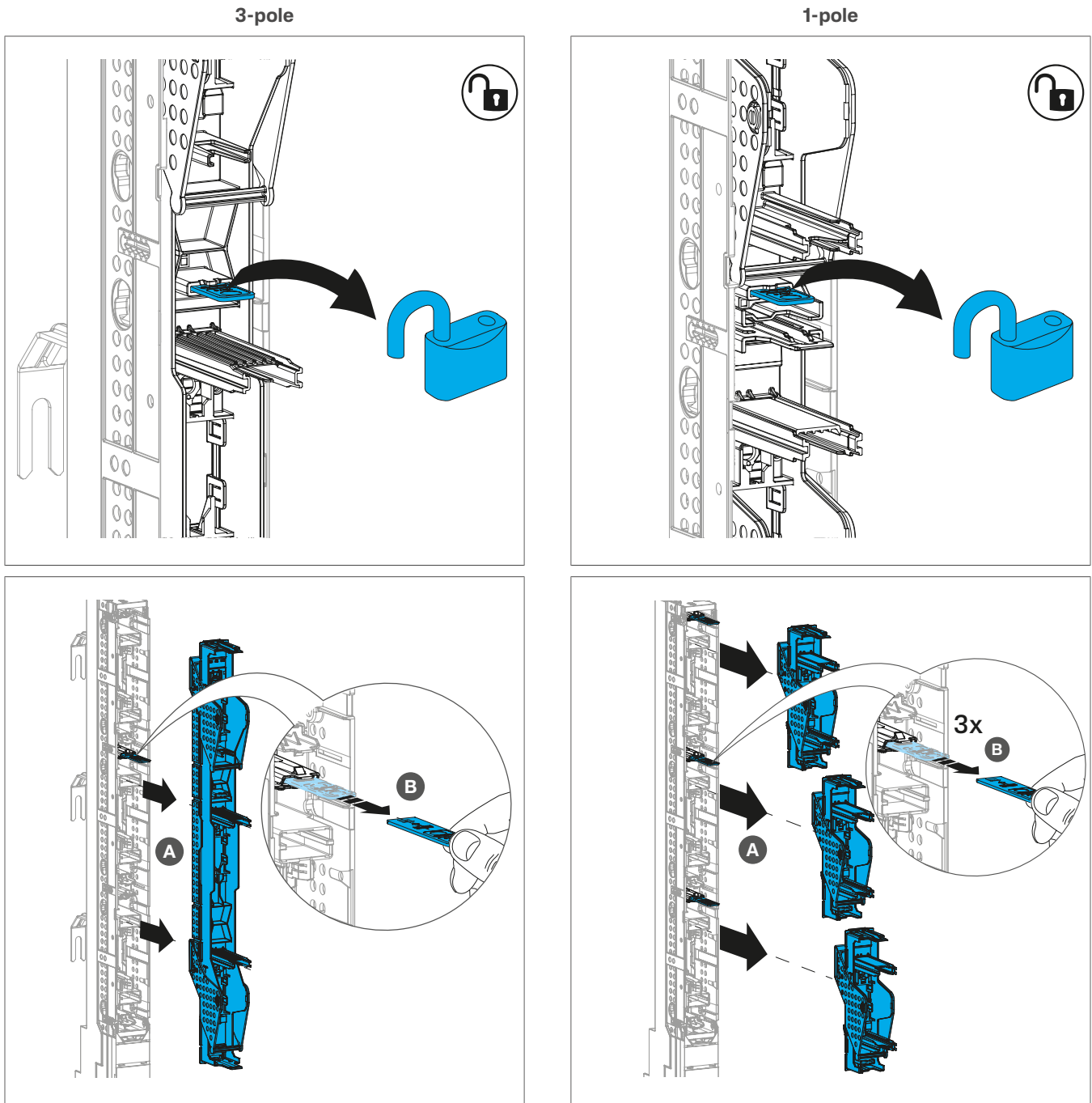

Figure: Unlocking the device in the park position

9.7 Locking piece storage

The locking piece LV8ZLP can be kept in a dedicated storage slot inside the fuse switch lid.

- Insert the locking piece into the dedicated slot until it clicks into place.

3-pole

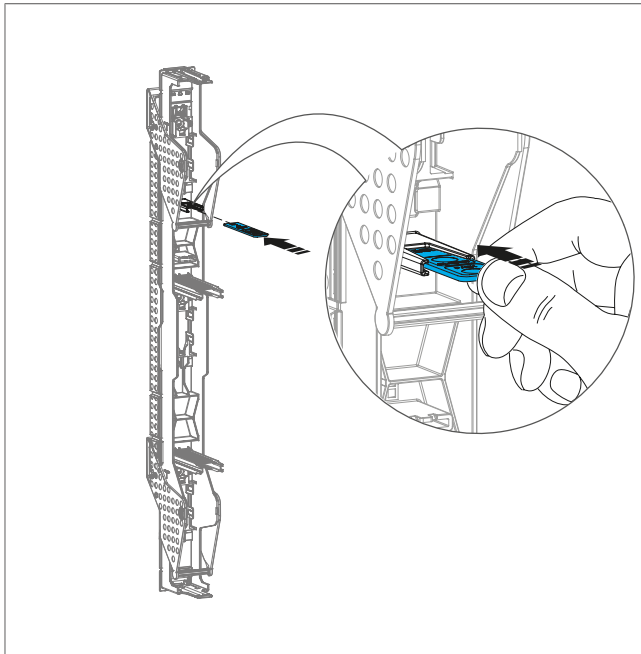

1-pole

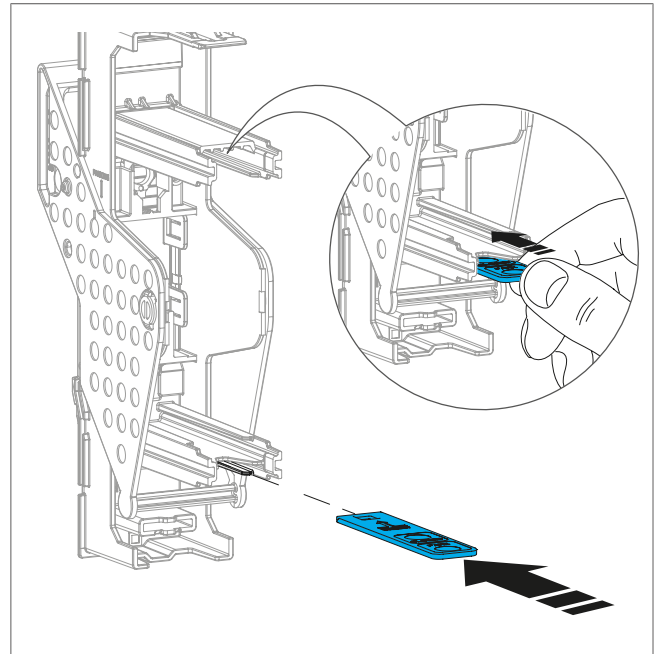

Figure: Locking piece storage

10 Electronic fuse monitoring system

Operation Conditions

- ☑ Correct switching state of auxiliary contacts only after commissioning, under voltage and with inserted fuse links.



NO 13-14	Open	Closed
NC 21-22	Closed	Open



Only use fuse links with live gripping lugs and ensure continuity between both gripping lugs. Check specifications of the fuse link manufacturer.

Testing fuse monitoring (FM test)

- ☑ The device is in operational mode.
- Test correct functioning of the fuse monitoring by pressing the test button located on the front top of the module.

During the test phase all LEDs will blink in red and the NO/NC state are switched.

After some seconds the LEDs return to steady green and the NO/NC return to normal state.



Do not remove any fuse links for testing.
 Generator operation is not possible.
 Device can be used regardless of the direction of current flow.

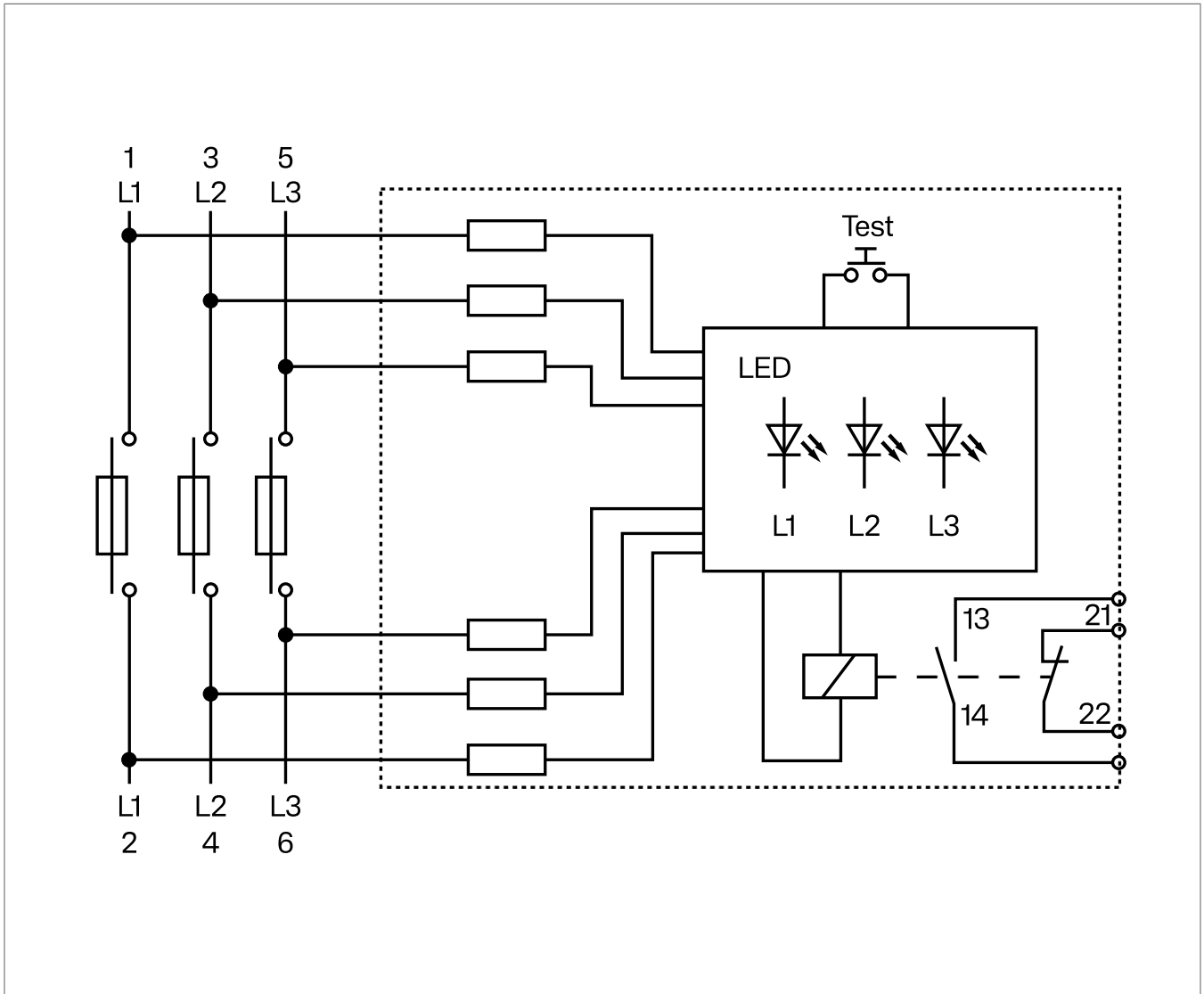



Figure: Terminal Diagram

Functional description

- Each phase (L1, L2, L3) has its own LED indicator, which indicates the status of the respective fuse link:

 LED steady green: The fuse link for the phase is intact (normal operation).

 LED blinking red: The fuse link for the phase has tripped.

- NO/NC output contacts switch if at least one fuse link has tripped.
- If one or more LEDs are off:
 - The power supply is interrupted on the relevant phase.
 - The device has failed or has a malfunction.
 - The fuse link status cannot be determined.

 Dielectric tests (electrical insulation tests) with 2200 V AC and 500 V DC for housing according to IEC 61439-1 can be performed without disconnecting the fuse monitoring.

Electronic fuse monitoring system

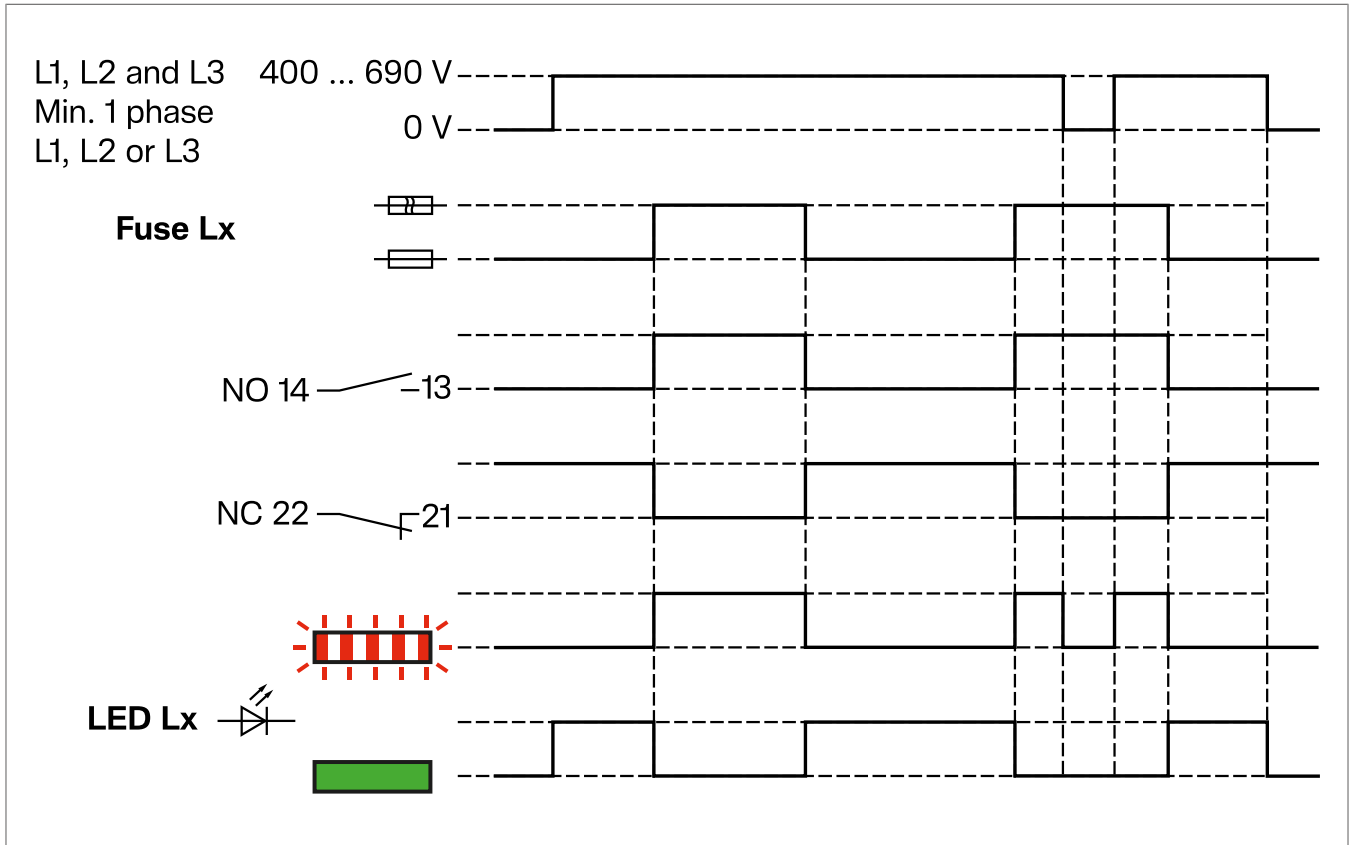

Figure: Functional diagram

Designation	Value	
Rated operating voltage U_e of the main switching device	AC 400 ... 690 V	
Rated insulation voltage U_i	AC 1000 V	
Nominal voltage of the supply system	AC 277 V/480 V	AC 400 V/690 V
Overtoltage category of the supply system	IV	IV
Rated impulse withstand voltage U_{imp} of the main switching device and electronic fuse monitoring system	6 kV	8 kV
Rated conditional short circuit current (with protection by NH fuse links)	Restriction specified by switching device.	
Permissible ambient temperature	-25 to +85 °C	
Function	Differential voltage > 30 V, independent of the incoming side.	
Signal output / Level of protection of secondary system	Relay with NO contact and NC contact. Output with reinforced insulation according to IEC 60947-1 (SELV).	
Rated voltage/current signal output	AC 250 V max. 5 A	
Rated frequency	50/60 Hz Combination with frequency converter operation is not permitted.	

Table 2: Technical data electronic fuse monitoring

11 Appendix

11.1 Technical data

Fuse switch disconnectors fv+ (LV8*) size NH00, elevated or flat

Without or with fuse monitoring (FM).

Description	NH00	NH00 + FM
Rated operating voltage U_e	690 V / 800 V ^[1] AC	690 V AC
Rated operating current I_e		
- 400 V	160 A	160 A
- 500 V	160 A	160 A
- 690 V	160 A	160 A
- 800 V	63 A	-
Frequency	50 Hz / 60 Hz	50 Hz / 60 Hz
Power dissipation of device without fuse-links	22 W	22 W
Power dissipation of device at full load	58 W	58 W
Max. power dissipation of fuse-links P_n	12 W	12 W
Operating temperature	-25 °C ... +55 °C	-25 °C ... +55 °C
Storage / transport temperature	-40 °C ... +70 °C	-40 °C ... +70 °C
Temperature Conventional free air thermal current I_{th} with fuse-links / with solid links	160 A / 220 A	160 A / 220 A
Utilization Category		
- 400 V	AC23-B / 160 A	AC23-B / 160 A
- 500 V	AC22-B / 160 A	AC22-B / 160 A
- 690 V	AC22-B / 160 A	AC22-B / 160 A
- 800 V	AC21-B / 63 A	-
Rated conditioned short-circuit current		
- 400 V	120 kA	120 kA
- 500 V	120 kA	120 kA
- 690 V	100 kA	100 kA
- 800 V	30 kA	-
Rated short-time withstand current I_{cw} 1 s	5 kA	5 kA
Rated insulation Voltage U_i	1000 V	1000 V
Rated impulse withstand voltage U_{imp}	8000 V	8000 V
Overload category	IV	IV
Degree Pollution according IEC 60664	3	3
IP Protection		
- Front with closed cover	IP3X	IP3X
- Front with opened cover	IP2X	IP2X
- Lateral Side	IP2X	IP2X
- Front without cover	IP2X	IP2X
Electric endurance in number of cycles	200	200
Number of mechanical operations	1400	1400

[1] No restrictions to switch off the handle under load at 800 V AC. Use appropriate personal protective equipment.

11.2 Disposal note

Disposal note



Correct disposal of this product (electrical waste).

(Applicable in the European Union and other European countries with separate collection systems)

This marking shown on the product or its documentation indicates that it should not be disposed of with other household waste at the end of its working life. To prevent possible harm to the environment or human health from uncontrolled waste disposal, please separate this device from other types of waste. Recycle the device responsibly to promote the sustainable reuse of material resources.

Household users should contact either the dealer where they purchased this product, or their local government office, for details of where and how they can take this device for environmentally safe disposal.

Commercial users should contact their supplier and check the terms and conditions of the purchase contract. This product should not be mixed with other commercial waste for disposal.



Hager Electro GmbH & Co. KG

Zum Gunterstal

66440 Blieskastel

Germany

+49 6842 945 0

+49 6842 945 4625

info@hager.com

hager.com