

Light control

Dimmer insert

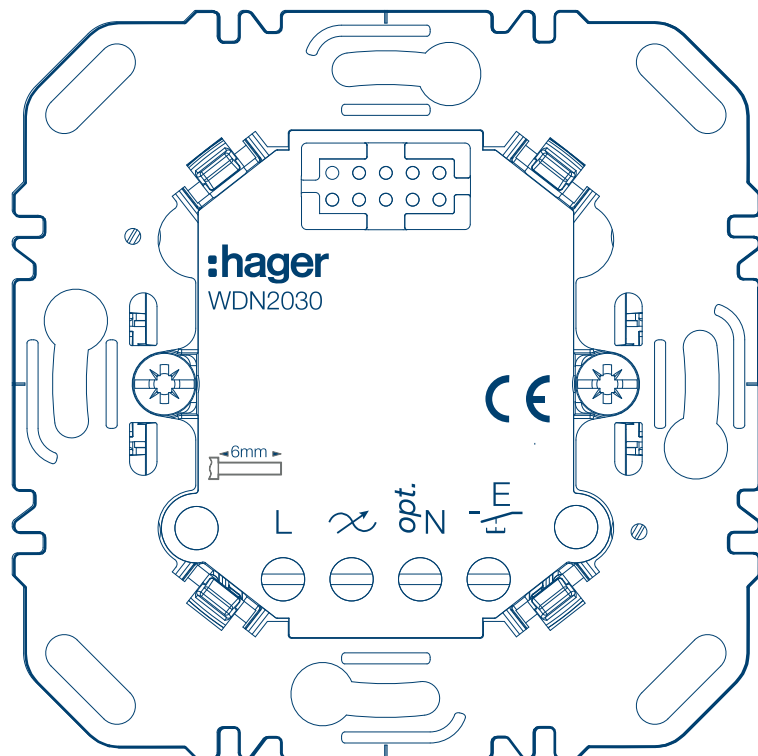

Dimmer insert, 1-gang
WDN2030

CE

1	Introduction.....	3
2	Safety instructions.....	4
3	Design and layout of the device.....	5
3.1	Dimensions.....	5
4	Function.....	6
4.1	Intended use.....	6
4.2	Product characteristics.....	6
5	Operation.....	7
6	Installation and electrical connection.....	8
7	Technical data.....	11
8	Accessories.....	13
9	Troubleshooting.....	14
10	Disposal note.....	15

1 Introduction

This manual describes the installation of the dimmer insert. The device is part of the modular electronics platform, which can be connected via the Matter wireless standard.

In addition to the Quick Guide provided with the product, you can find:

- Detailed product characteristics
- Important notes on switching/dimming behaviour with connected loads
- Troubleshooting



► Also follow the operating instructions for the application module required for operation (e.g. Push button, connectable, 1-gang). They explain the operation of the complete device and the corresponding setting options.

System overview

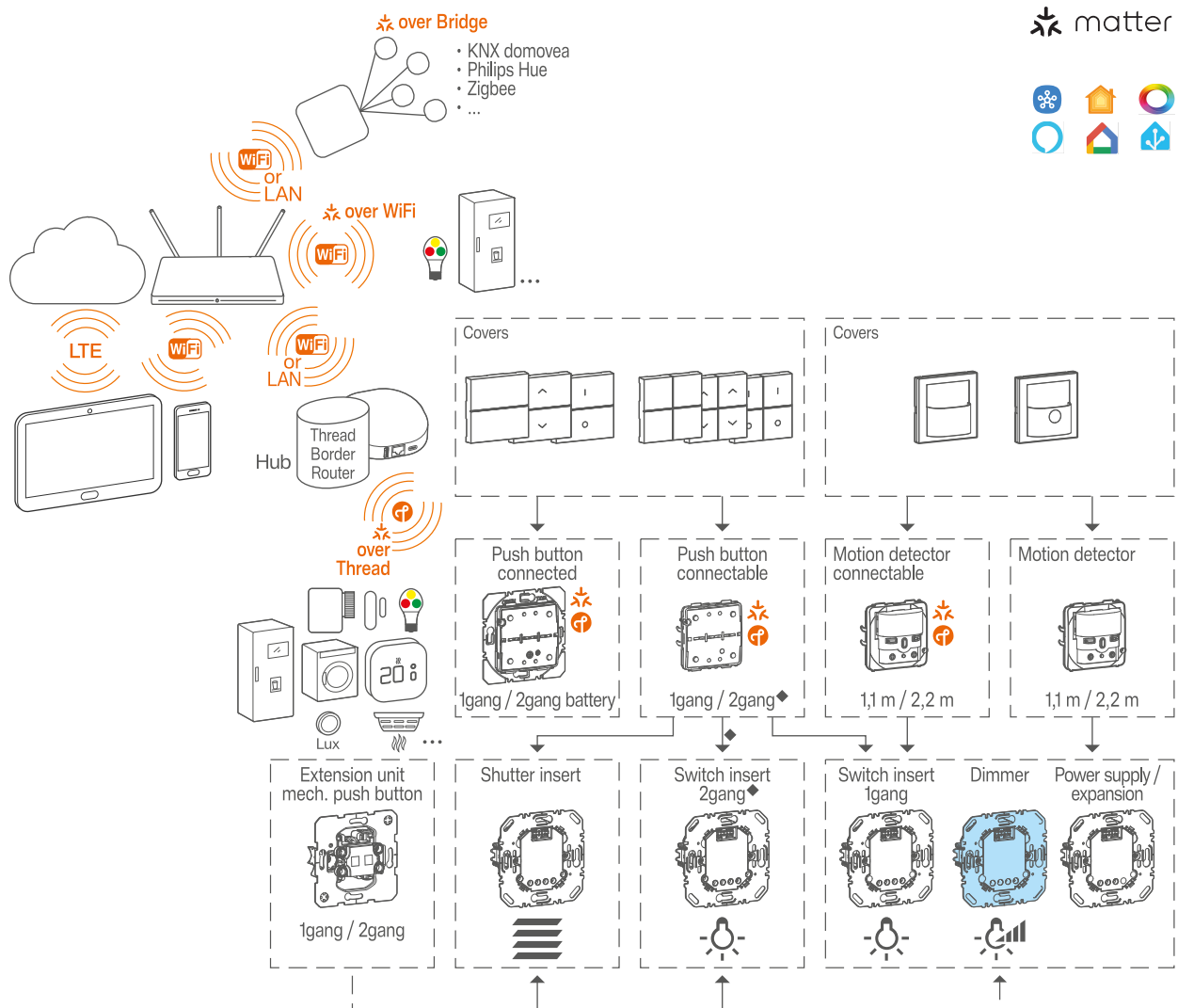

2 Safety instructions

Electrical devices may only be installed and assembled by a qualified electrician in accordance with the relevant installation standards, guidelines, regulations, directives, and safety and accident prevention regulations of the country of installation.

Failure to comply with these installation instructions may result in damage to the device, fire or other dangers.

Danger due to electric shock. Do not operate the device without application module.

Danger due to electric shock. The device is not suitable for safe disconnection of the mains supply. Even when the device is switched off, the load is not galvanically separated from the mains supply.

Do not connect any non-dimmable lamps, their transformers or operating devices. Observe manufacturer's data.

Fire hazard. When operating with conventional transformers, secure each transformer on the primary side according to the manufacturer's specification. Use safety transformers that comply with EN 61558-2-6 (VDE 0570 Part 2-6) only.

3 Design and layout of the device

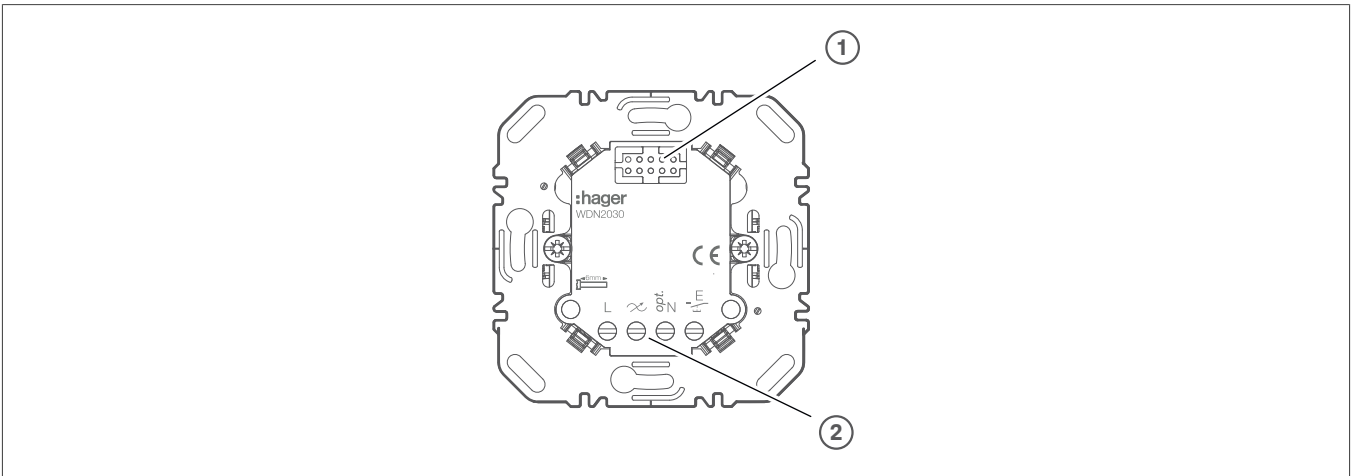

- ① Interface between insert/application module
- ② Connecting terminals

3.1 Dimensions

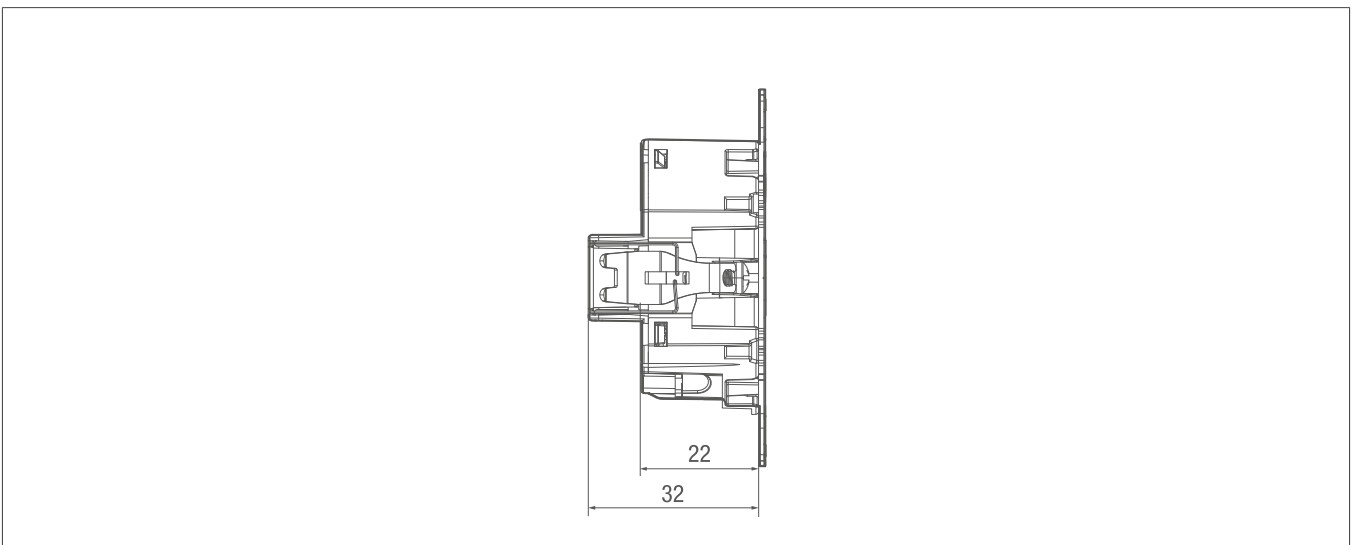

Fig. 1: Built-in depth

4 Function

4.1 Intended use



Switch and dim lighting. Supported load types and power values see Technical Data.



Only suitable for use in indoor areas with no drip and no spray of water

Installation into wall box according to DIN 49073 (recommendation: Deep box)

Operation with a suitable application module (see Accessories)



Only use dimmable loads.

No mixed load operation of capacitive and inductive loads possible.

4.2 Product characteristics

- Automatic setting of load-dependent dimming principle and optional settings via the application module e.g. for dimmable 230 V LED lamps
- Soft start for bulb protection
- Electronic short circuit protection
- Electronic overload and overheating protection
- Electronic interference signal suppression e.g. for ripple control pulses
- Minimal switch-on brightness level either factory-set or settable manually via the application module.
- Extension unit for push button (NO contact) or motion detector extension units ([see Accessories](#))
- Advanced smart home functions when using a Matter compatible application module

5 Operation

Refer to the operating manual of the appropriate application module for information on operation and load adjustment (Refer to Accessories).



Operation, including operation of extension units, is only possible if an application module is attached to the insert.

Information on the dimming behaviour



In 230 V LED lamps, the power supply of the switch insert can cause the lamp to glow slightly even when it is switched off.

Brief flickering during load detection possible. No operation is possible during load detection. This situation does not indicate a defect in the device.

Flickering of connected lamps possible due to the load falling below the specified minimum level, ripple control pulses (tariff signals) from power stations, or replacement of 230 V LED lamps.

If the switching and dimming performance is unsatisfactory in the factory setting, a load setting must be carried out ► see 'Operating instructions of the application module'.

6 Installation and electrical connection



Danger

Electric shock when live parts are touched!

An electric shock can lead to death!

- Disconnect all connection cables before working on the device and cover any live parts in the area!

☑ A miniature circuit breaker in accordance with the connection diagram must be installed as device protection.

① Connect the device according to the connection diagram (Figure 2, 3 or 4).

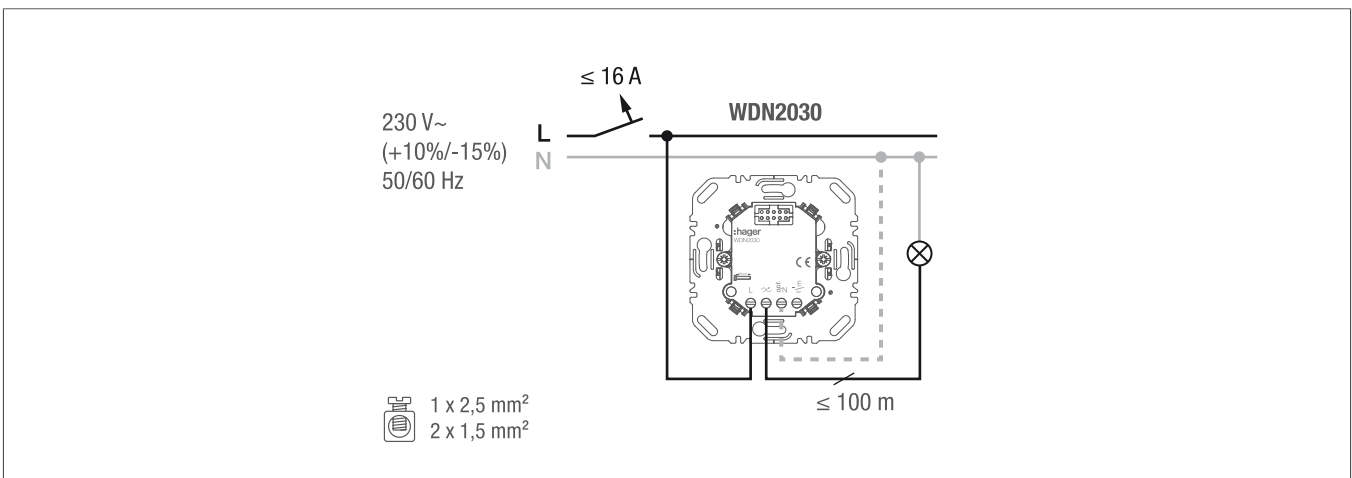

Fig. 2: Connection diagram



The dimmer insert has an optional N-terminal. Operation without neutral conductor possible.

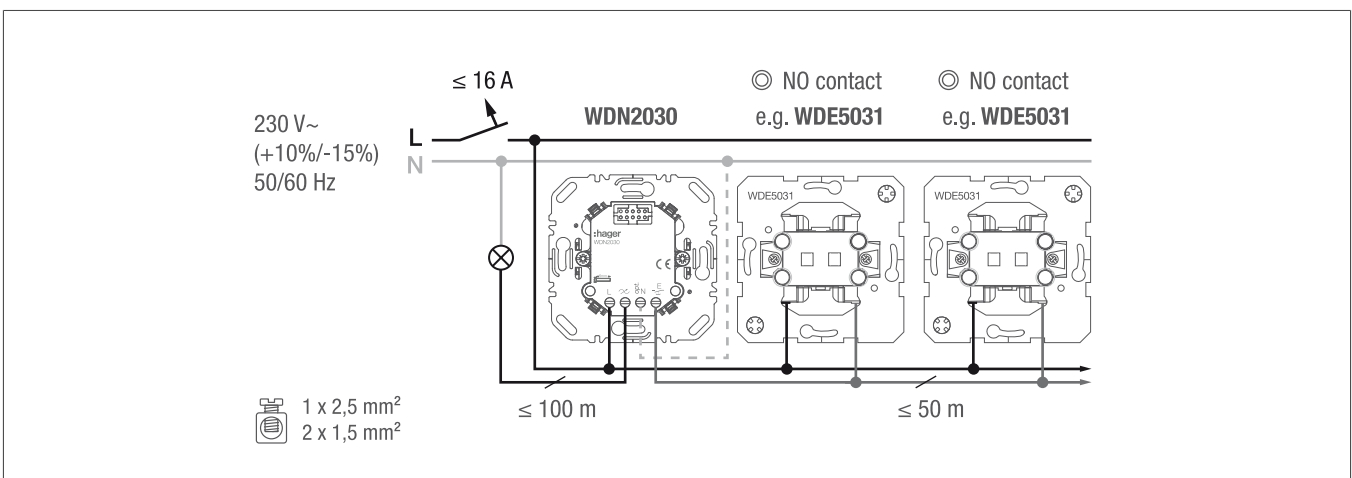

Fig. 3: Connection diagram with optional button extensions



Illuminated mechanical push button extension units must be equipped with a separate N terminal.

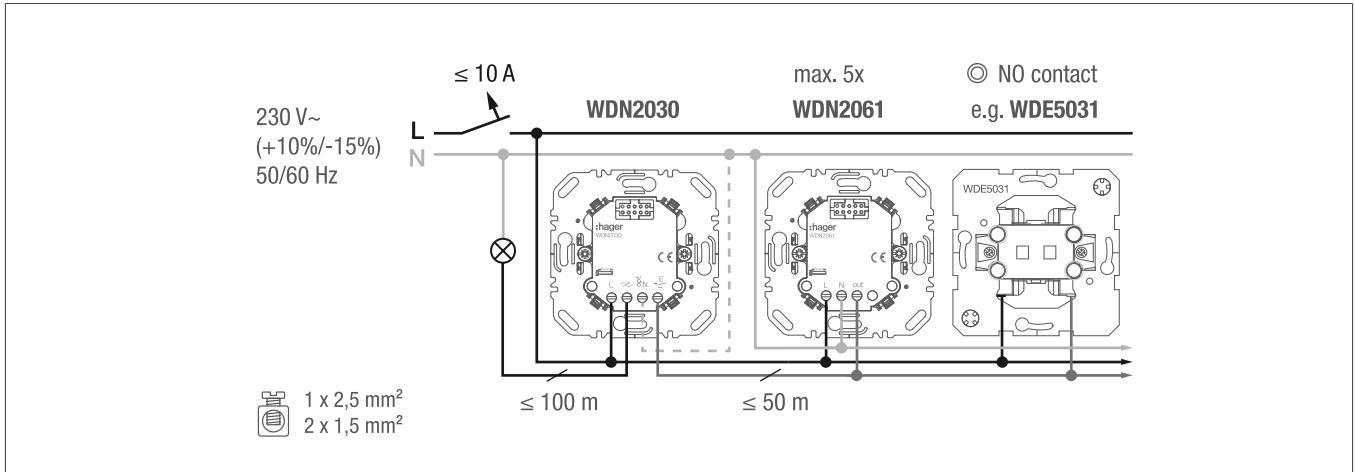
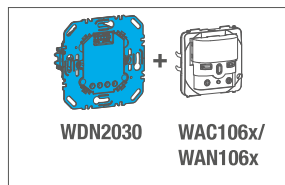

Fig. 4: Connection diagram with optional motion detector extension units and mechanical button extension units



Only use motion detector extension units if the dimmer insert is operated with a motion detector application module.



Motion detector main unit

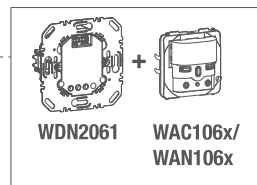

Motion detector extension unit



Note: If a WAC1010/WAC1020 button module is used as an application module, extension unit operation with the WDN2061 is not possible.

- 2 Install the device into a wall box. The connection terminals must be at the bottom.

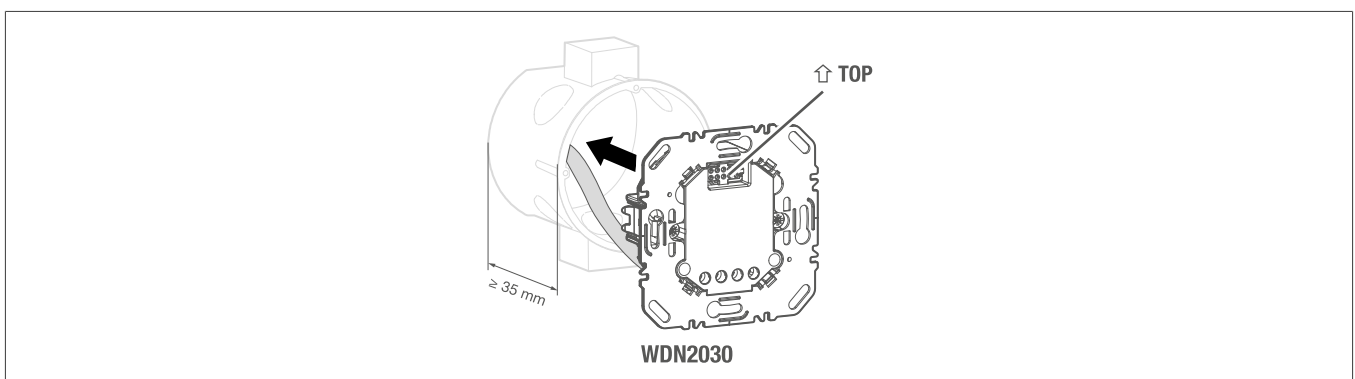

- 3 Mount the frame and application module. ► Follow the instructions for the application module used.
- 4 Secure the application module to the insert using the fixing screw.
- 5 Install the appropriate cover.

Installation and electrical connection

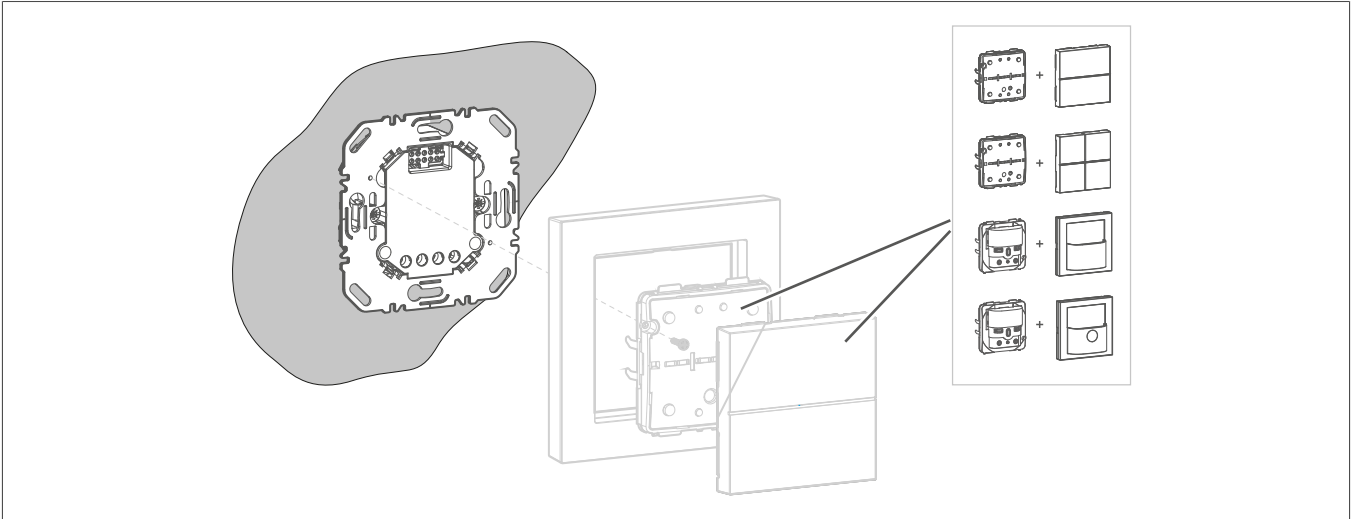

7 Technical data

Nominal voltage	AC 230 V~ (+10% / -15%)
Mains frequency	50/60 Hz
Power consumption (standby)	< 0.2 W
Performance values	(see Tab. 1)
Connecting terminals	1 x 2.5 mm ² / 2 x 1.5 mm ²
Power cable length	Max. 100 m
Extension unit cable length	Max. 50 m
Number of extension unit push buttons, unilluminated	unlimited
Number of extension units for power supply module WDN2061 + application module	5
Built-in depth housing	22 mm
Claw guidance installation depth	32 mm
Operating temperature	-5 °C ... +45 °C
Storage/transport temperature	-20°C ... +60°C
Relative humidity (without condensation)	10 ... 95 %
Degree of protection	IP20

Type of load	Performance values
Incandescent lamps, HV halogen lamps	
- At 50 Hz	20 ... 350 W
- At 60 Hz	20 ... 325 W
NV halogen lamps	
- with electronic/dual-mode transformers	20 ... 400 VA
- with conventional transformers	20 ... 200 VA
Dimmable 230 V LED lamps (phase cut-on)	
- At 50 Hz	3 ... 60 W
- At 60 Hz	3 ... 55 W
Dimmable 230 V LED lamps (phase cut-off)	3 ... 200 W

Table 1: Load types - Power values at 25°C

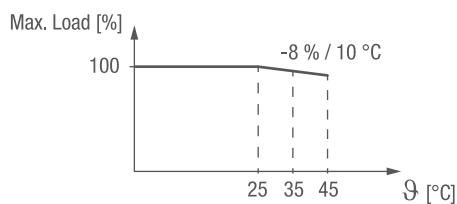

Fig. 5: Performance reduction per 10°C above 25°C

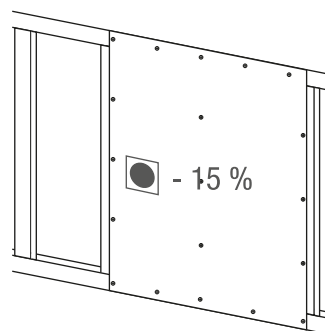

Fig. 6: Performance reduction when installed in hollow walls

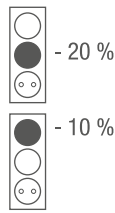

Fig. 7: Performance reduction when installed in multiple combinations

Important information about LED lamps:



Power data for LED lamps are typical values for 230 V mains voltage.

For LED loads of 50 W or more, we recommend operation in “LED mode 2”. ► See the operating instructions of the application module.

If the switching/dimming performance here is not satisfactory, the “Load factory setting” or “LED mode 1” can be selected as an alternative. Note: In “LED mode 1”, the connection output is typically limited to 60 W, depending on the LED!

Do not use non-dimmable 230 V LED lamps.

Important information about transformers:



Conventional transformers should be operated with a minimum nominal load of 50%. Nonetheless, 75% is recommended because in individual cases, depending on the transformer, unstable dimming performance may occur.

Carry out loading of conventional, electronic and dual-mode transformers according to the manufacturer's instructions.

Important notes for connecting multiple loads:









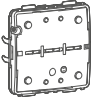
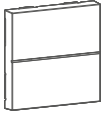
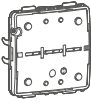
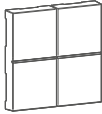

When connecting several loads to the output (parallel connection), optimise dimming performance via the load setting if necessary.

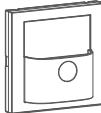
Mixed loads can be connected, provided the total does not exceed the lowest maximum load rating.

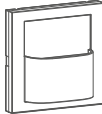
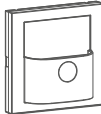
No mixed load operation of capacitive and inductive loads possible.

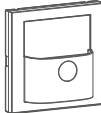
8 Accessories

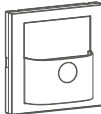
Compatible application modules		+ Correct covers			
	WAC1010 Push button (Matter compatible), 1-gang		WAN7010xx		
	WAC1020 Push button (Matter compatible), 2-gang		WAN7020xx		
	WAC1061 Motion detector (Matter compatible), installation height 1.1m		WAN7030xx		WAN7040xx
	WAC1062 Motion detector (Matter compatible), installation height 2.2m		WAN7030xx		WAN7040xx
	WAN1061 Motion detector, installation height 1.1m		WAN7030xx		WAN7040xx
	WAN1062 Motion detector, installation height 2.2m		WAN7030xx		WAN7040xx

9 Troubleshooting

Device switches off and can only be switched back on after a certain time.

Electronic overheating protection has triggered.

- 💡 Reduce connected load.
- 💡 Check the system situation.

The device switches off but can be switched on again.

- 💡 Short circuit protection has triggered, but in the meantime there is no longer a fault.

If the switching/dimming performance of 230 V LED lamps is unsatisfactory:

- 💡 Carry out a load setting. ► See the instructions for the application module used.



For LED loads of 50 W or more, we recommend operation in “LED mode 2”. Alternatively, the ‘Load factory setting’ or ‘LED mode 1’ can be selected. Note: In “LED mode 1”, the connection output is typically limited to 60 W, depending on the LED!

For flickering after replacing the lamp:

- 💡 Carry out a load setting. ► See the instructions for the application module used.

10 Disposal note

Disposal note



Correct disposal of this product (electrical waste).

(Applicable in the European Union and other European countries with separate collection systems)

This marking shown on the product or its documentation indicates that it should not be disposed of with other household waste at the end of its working life. To prevent possible harm to the environment or human health from uncontrolled waste disposal, please separate this device from other types of waste. Recycle the device responsibly to promote the sustainable reuse of material resources.

Household users should contact either the dealer where they purchased this product, or their local government office, for details of where and how they can take this device for environmentally safe disposal.

Commercial users should contact their supplier and check the terms and conditions of the purchase contract. This product should not be mixed with other commercial waste for disposal.



Berker GmbH & Co. KG

Zum Gunterstal

66440 Blieskastel

Germany

T +49 6842 945 0

F +49 6842 945 4625

info@hager.com

hager.com