

# Switch ranges

## Temperature controller

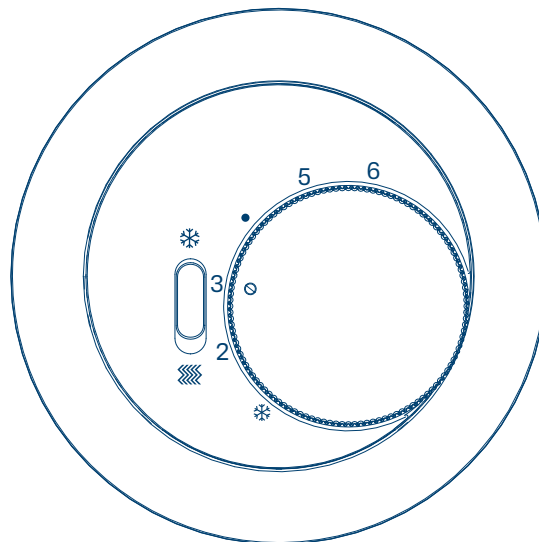

Thermostat, change-over contact with rocker switch heating/cooling

**WLN5029xx**

CE

<b>1</b>	<b>Safety instructions.....</b>	<b>3</b>
<b>2</b>	<b>Design and layout of the device.....</b>	<b>4</b>
<b>3</b>	<b>Function.....</b>	<b>5</b>
3.1	Intended use.....	5
<b>4</b>	<b>Operation.....</b>	<b>6</b>
<b>5</b>	<b>Information for qualified electricians.....</b>	<b>7</b>
5.1	Installation and electrical connection.....	7
5.2	Commissioning.....	9
<b>6</b>	<b>Appendix.....</b>	<b>10</b>
6.1	Technical data.....	10
6.2	Troubleshooting.....	10
6.3	Disposal note.....	10

# 1 Safety instructions

Electrical devices must only be installed and assembled by a qualified electrician in accordance with the relevant installation standards, guidelines, regulations, directives, safety and accident prevention directives of the country.

Failure to comply with these installation instructions may result in damage to the device, fire or other hazards.

## 2 Design and layout of the device

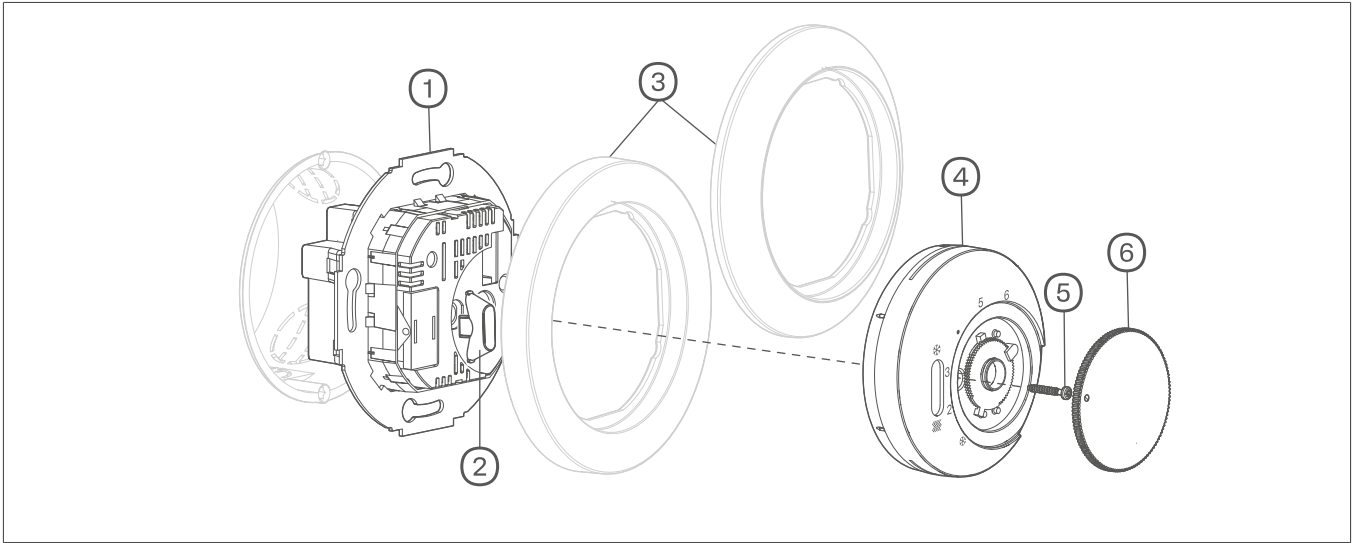

Fig. 1: Design and layout of the device

- ① Thermostat module
- ② Rocker for switch heating/cooling
- ③ Cover frame Serie 1930/R.classic (not included)
- ④ Centre piece with scale
- ⑤ Fastening screw
- ⑥ Setting knob

## **3 Function**

The thermostat controls the temperature in indoor locations. It is controlled using the measured value provided by the internal temperature sensor. The thermal re-circulation (thermal resistor) achieves efficient control during heating operation.

The thermostat incorporates a switch, enabling switching between heating and cooling control.

### **3.1 Intended use**

- For indoor temperature control
- Only suitable for indoor applications
- Installation in wall box according to DIN 49073 (deep box recommended)

## 4 Operation

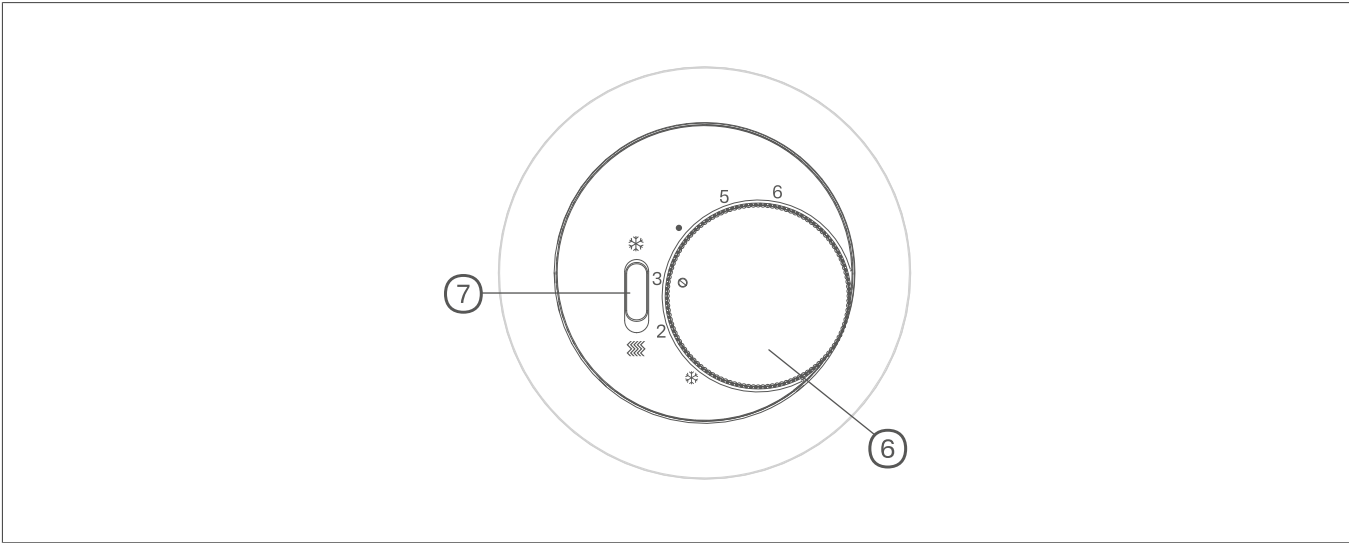

Fig. 2: Control elements

- ⑥ Setting knob
- ⑦ Rocker switch heating/cooling

### Switching heating or cooling mode

i

**Note**

The printing of the heating/cooling slide switch is designed for normally closed valves.

- Set the rocker switch (7) to the desired position.

- ☞ Heating
- ❄ Cooling

The selected operating mode is executed.

### Setting the temperature setpoint

Specify the room temperature setpoint using the setting knob (6):

- Heating:  
When the setpoint is undershot, the device switches on.
- Cooling:  
When the setpoint is exceeded, the device switches on.

The setting range is 5°C to 30°C.

<b>Setting value (scale)</b>	❄	2	3	●	5	6
<b>Temperature [°C]</b>	5	10	15	20	25	30

Table 1: Setting values of the setting knob

- Turn the setting knob to the desired setting.

## 5 Information for qualified electricians

### 5.1 Installation and electrical connection



**Danger**

Electric shock when live parts are touched!

An electric shock can lead to death!

- Disconnect all connection cables before working on the device and cover any live parts in the area!

#### Selecting the location for installation

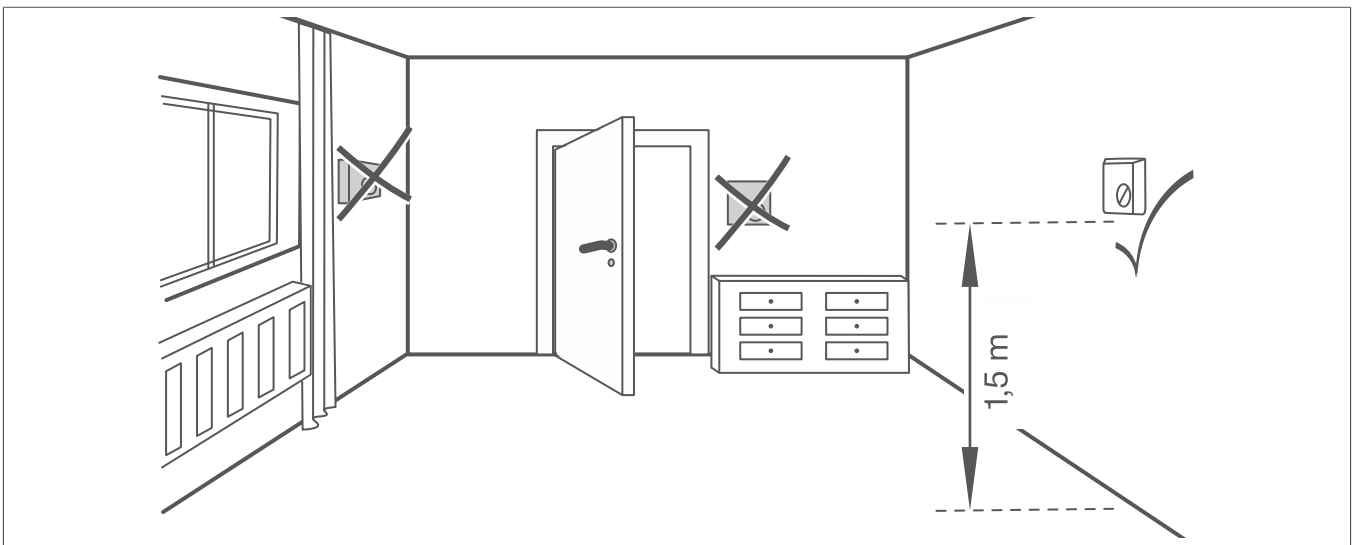

Fig. 3: Recommended installation location

- An inside wall opposite the heating source is the preferred installation location.
- Optimal installation height approx. 1.5 m above the floor.
- Avoid drafts near windows and doors.
- The heated room air should reach the controller without hindrance. Do not mount the controller within shelving units or behind curtains and similar coverings.
- Extraneous heat affects the control accuracy. Avoid direct sunlight and do not install near televisions, radios and heating appliances, lamps, chimneys and heating pipes.
- Avoid mounting in combination with dimmers. If necessary, maintain the greatest possible distance between the two devices. In the case of an arrangement one above the other, the controller must be arranged below the dimmer.
- When mounting the device in hollow walls, ensure that the controller is not exposed to any outside heating or cooling from air draughts or rising cables, also on the rear side.

## Connection and installation of the device

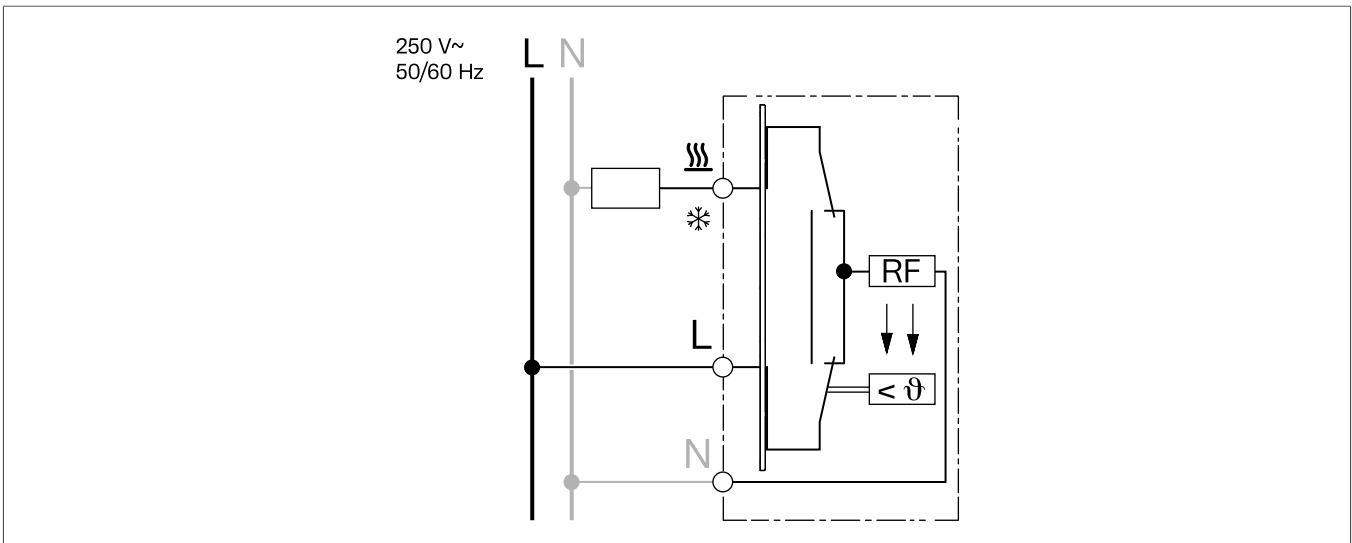

Fig. 4: Connection diagram

**L** Outer conductor (phase)

**N** Neutral conductor

Load connection heating/cooling

**RF** Thermal resistor thermal re-circulation



### Note

The printing of the heating/cooling slide switch is designed for normally closed valves. A maximum of 5 valve drives may be connected to the device.

The **N** conductor must be connected to the thermal re-circulation as a power supply, otherwise large temperature variations should be expected.

- 1 Connect the controller (1) according to the connection diagram (Fig. 4).
- 2 Insert the rocker for heating/cooling switch (2) into the right-hand opening of the rocker switch (7)(Fig. 1).
- 3 Position the centre piece (4) correctly over the cover frame (3) and secure it using the fastening screw (5).
- 4 Attach the setting knob (6).



### Serie 1930

Integration into the Serie 1930 is only possible using 1-gang cover frames with  $\varnothing$  a 58-mm cut-out (WTD3191xx). Installation in multiple-gang combinations is not possible.

## 5.2 Commissioning



### Note

The bi-metal element in the controller requires a certain amount of time to adjust itself to the room temperature. For this reason, the switching point will deviate from the room temperature directly after installation. Switching point accuracy will only occur after approx. 1 to 2 operating hours.

### Limiting the setting range

The temperature setting range can be limited individually using two setting rings under the setting knob.

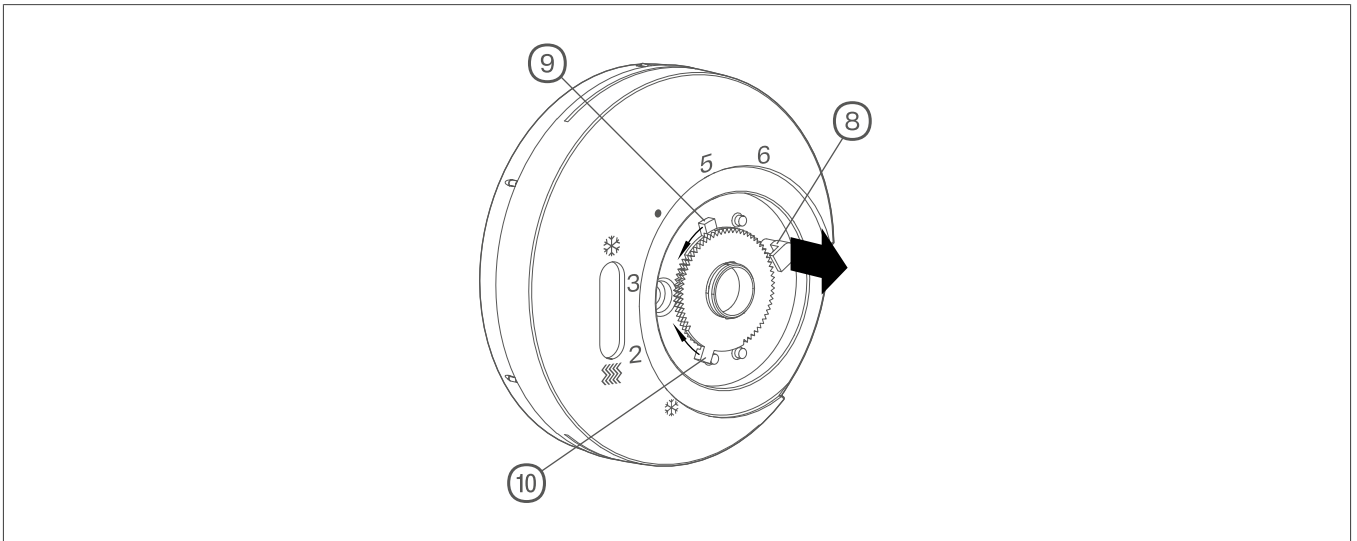

Fig. 5: Limiting the setting range on the centre piece

- ⑧ Locking pin
- ⑨ Setting ring, maximum temperature (red)
- ⑩ Setting ring, minimum temperature (blue)

- 1 Remove the setting knob (6).
- 2 Pull out the locking pin (8) so that the setting rings can be moved freely against each other.
- 3 To set the maximum setpoint, turn the red setting ring (9) in an anti-clockwise direction into the required position.
- 4 To set the minimum setpoint, turn the blue setting ring (10) in a clockwise direction into the required position.



### Note

The printed scale can be used as a rough guide for the setting.

- 5 Push in the locking pin up to the stop.  
The setting rings are locked again.
- 6 Attach the setting knob. When doing this, ensure that the nose on the rotation axis is guided into the appropriate cut-out in the holder of the controller.  
The temperature can be adjusted within the permitted setting range.

## 6 Appendix

### 6.1 Technical data

Type of contacts	Change-over contact
Operating voltage	AC 250 V~, 50 Hz
Rated current heating/cooling	5 (2) A
Temperature setting range	0 ... 30°C
Operating temperature	0 ... 40°C
Storage temperature	-20 ... +70°C
Switching difference temperature	approx. 0.5 K
Temperature change speed of the controlled system	max. 4 K/h
Pollution degree	2
Relative humidity	0 ... 95 % (without condensation)
Degree of protection	IP20
Protection class (when fully assembled)	II
Voltage & current for EMC emission test	230 V/50 Hz
Rated surge voltage	4 kV
Action type	1 C
Software class(es) and structure	Class A
Temperature of the ball pressure test	125 °C
<b>Connecting screw terminals</b>	
Rigid	1 ... 2.5 mm <sup>2</sup>

### 6.2 Troubleshooting

#### Large temperature variations in control

**No thermal feedback because no N-conductor was connected.**

💡 Connect neutral conductor **N**.

### 6.3 Disposal note



**Correct disposal of this product (electrical waste).**

#### (Applicable in the European Union and other European countries with separate collection systems)

This marking shown on the product or its documentation indicates that it should not be disposed of with other household waste at the end of its working life. To prevent possible harm to the environment or human health from uncontrolled waste disposal, please separate this device from other types of waste. Recycle the device responsibly to promote the sustainable reuse of material resources.

Household users should contact either the dealer where they purchased this product, or their local government office, for details of where and how they can take this device for environmentally safe disposal.

Commercial users should contact their supplier and check the terms and conditions of the purchase contract. This product should not be mixed with other commercial waste for disposal.



**Berker GmbH & Co. KG**

Zum Gunterstal

66440 Blieskastel

Germany

T +49 6842 945 0

F +49 6842 945 4625

info@hager.com

**hager.com**