

Installation and operating manual

# Charging station witty one

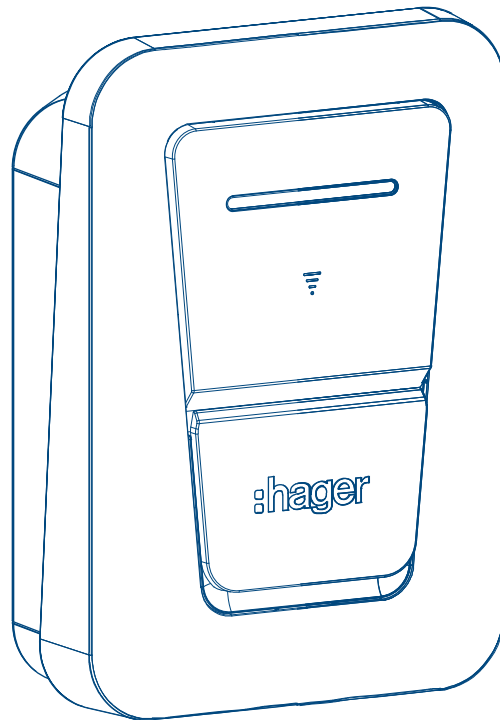

Electric vehicle charging station  
**XVU122SCT-MO**

UK  
CA

**:hager**

<b>1</b>	<b>About this manual.....</b>	<b>4</b>
1.1	Symbols used.....	4
1.2	Affected groups.....	5
<b>2</b>	<b>Safety.....</b>	<b>6</b>
2.1	Correct use.....	6
2.2	Safety instructions.....	6
<b>3</b>	<b>Overview.....</b>	<b>8</b>
3.1	Scope of delivery.....	8
3.2	Dimensions.....	8
3.3	Tools required.....	8
<b>4</b>	<b>Overview of the device.....</b>	<b>9</b>
4.1	External view of the device.....	9
4.2	Internal view of the device.....	9
<b>5</b>	<b>Installation.....</b>	<b>11</b>
5.1	Protective device requirements.....	11
5.2	Pen fault detection.....	13
<b>6</b>	<b>Mounting the charging station.....</b>	<b>14</b>
6.1	Preparatory work.....	14
6.2	Wall mounting.....	15
<b>7</b>	<b>Electrical connection.....</b>	<b>17</b>
7.1	Connection to the power terminal block.....	17
7.2	Connection of the metering board with CT.....	18
<b>8</b>	<b>Settings.....</b>	<b>22</b>
8.1	Operating current and connection type.....	22
8.2	Reset from the charging station.....	22
<b>9</b>	<b>Final assembling.....</b>	<b>24</b>

<b>10</b>	<b>Commissioning.....</b>	<b>25</b>
<b>11</b>	<b>Advanced Configuration.....</b>	<b>26</b>
11.1	Configuration via the Hager charge application.....	26
11.2	Configuration via Monta.....	29
<b>12</b>	<b>Charging station operation.....</b>	<b>31</b>
12.1	Operation with a badge.....	31
12.2	Operation with the MONTA app.....	32
<b>13</b>	<b>Charging an electric vehicle.....</b>	<b>33</b>
13.1	Preparation for a charging session.....	33
13.2	Stopping a charging session.....	33
13.3	LED light strip.....	33
<b>14</b>	<b>Maintenance.....</b>	<b>35</b>
<b>15</b>	<b>Appendix.....</b>	<b>36</b>
15.1	Technical specifications.....	36
15.2	Identification of compatible vehicles in accordance with EN 17186.....	37
15.3	CE+UKCA Declaration of Conformity.....	37
15.4	Disposal of the charging station.....	37
15.5	Warranty.....	38
15.6	Software security updates.....	38

# 1 About this manual

This manual describes the correct and safe installation and commissioning of the charging station for electric vehicles. These instructions are an integral part of the device. Keep these instructions throughout the service life of the device and pass them on if necessary.

## 1.1 Symbols used

### Text icons





Symbol	Description
●	Action instruction in a single step or in any order.
①	Instructions for multi-step actions. Order must be complied with.
-	Enumeration
▶	Reference to documents / additional information

### Indication icons



	Contents of the package		Product dimensions		Tools required
	Mounting		Installation		Final mounting
	Description of the device		Settings		Optional accessories
	Installation by an electrician		Alternating current (IEC 60417-5032)		Protective earth (IEC 60417-5019)
	Applicable throughout Europe and Switzerland		When displayed on a device or attached to the documents of the product, the symbol opposite indicates that the device must not be disposed of with household waste when it reaches the end of its service life.		For more information, refer to the installation and commissioning instructions
	Applicable in the United Kingdom				

### Degrees of danger warnings

Symbol	Signal word	Consequences in case of non-compliance
	Danger	Causes serious injury or death.
	Warning	May cause serious injuries or death.
	Caution	May cause minor injuries.
	Attention	May cause damage to the device.
	Comment	May cause damage.

Symbol	Description
	Risk of electric shock.
	Risk of damage due to mechanical overload.
	Risk of damage from electricity. Risk of electric shock
	Risk of fire damage.

**Information**

Symbol	Signal word	Definition
	Comment	Indicates important instructions for use.
	Information	Indicates useful information about the product.

**1.2 Affected groups**



The assembly, installation and configuration of electronic devices must only be carried out by a specialist trained in the electrotechnical field and certified in compliance with the local installation standards in force. Accident prevention recommendations applicable in the country must be complied with.

These instructions are also intended for the operator of the charging station and for specialists trained in the electrotechnical field.

Commissioning requires knowledge of network technology.

## 2 Safety

### 2.1 Correct use

The charging station is used to charge electric or rechargeable hybrid vehicles. It is only intended for use in private and semi-public areas with open access (private properties, company car parks or depots). It is designed to be mounted in a fixed vertical position on a wall or stand, either indoor or outdoor.

The charging station should be permanently connected to the AC mains. The charging stations comply with the Radio Equipment Directive 2014/53/EU (RED) and SI 2017/1206 Radio Equipment Regulations 2017 (as amended).

#### Restrictions on use

Installation on the ceiling of a room or on the ground is prohibited. Any intervention in internal areas of the device and any modification of the pre-wiring, other than the operations described in this manual, is prohibited and voids the warranty, as well as any other form of guarantee. Interventions of this type can damage electronic components.

### 2.2 Safety instructions



#### Danger

Risk of injuries that may cause death in case of electric shock

- Before working on the device, the upstream circuit breaker(s) must be switched off. After opening the charging station, make sure that all power cables are voltage-free.
- When installing, doing maintenance work, or restoring power to the charging station, ensure that ambient conditions, such as rain, fog, snow, dust or wind, do not constitute a source of danger.



#### Warning

Risk of fire due to device overload

If the power cable is not properly dimensioned, there is a risk of fire due to device overload.

- Prepare the power cable according to the technical specifications of the device.



#### Caution

Risk of injury due to falling/tipping of the charging station

Use appropriate fixings to prevent the charging station from falling and causing injuries.

- Adapt the installation accessories to the requested conditions at the installation location. The fixings supplied are suitable for concrete and masonry.



#### Caution

Risk of damage to the charging station if prohibited charging accessories are used

- Do not use a connection adapter between the charging cable and the vehicle.
- The charging cable must not be extended.

**Warning**

Risk of data loss when connected to the Internet

Unauthorised access can result in loss of data.

- Before operating the device, appropriate security measures must be taken to protect the network from unauthorised access.

**Warning**

Risk of malfunctioning due to electromagnetic influences

Electromagnetic fields can interfere with the transmission of signals through very low voltage lines.

- Please follow the recommendations and standards applicable for SELV electrical circuits during cable installation.
- Lay power lines and extra low voltage (Ethernet) lines separately from each other.

### 3 Overview

#### 3.1 Scope of delivery

- Make sure the contents of the package are complete and intact.

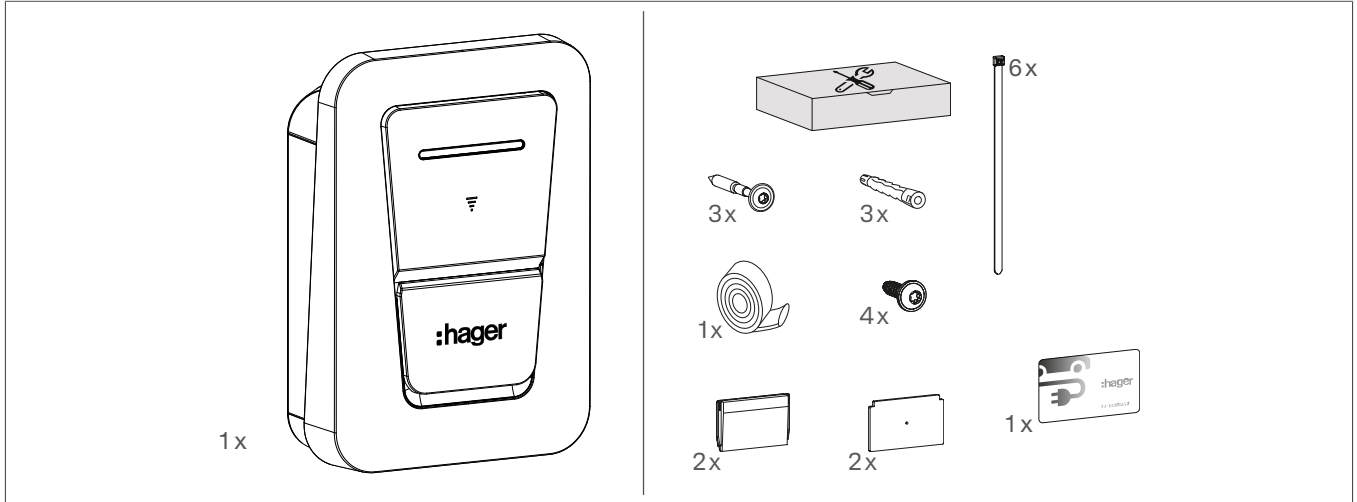

#### 3.2 Dimensions

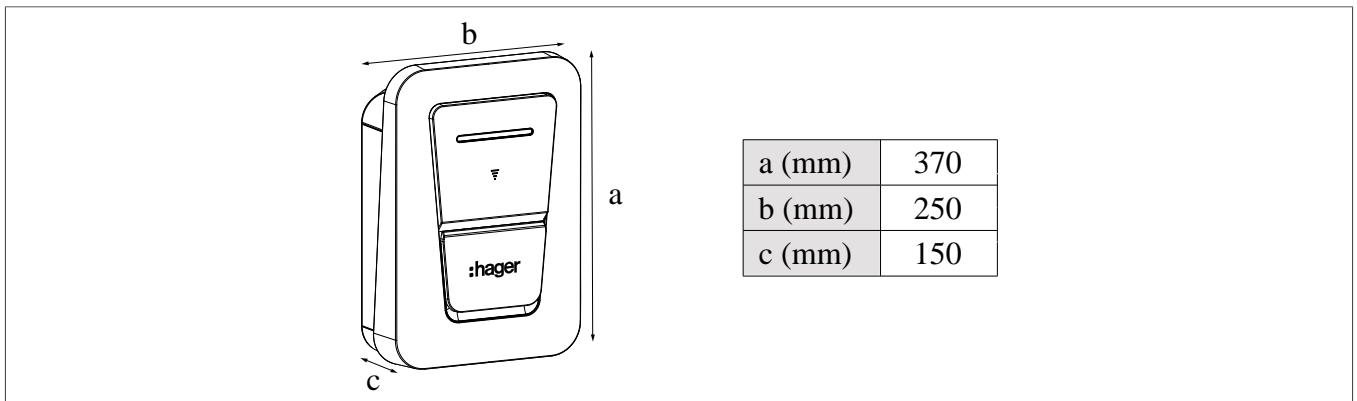

#### 3.3 Tools required

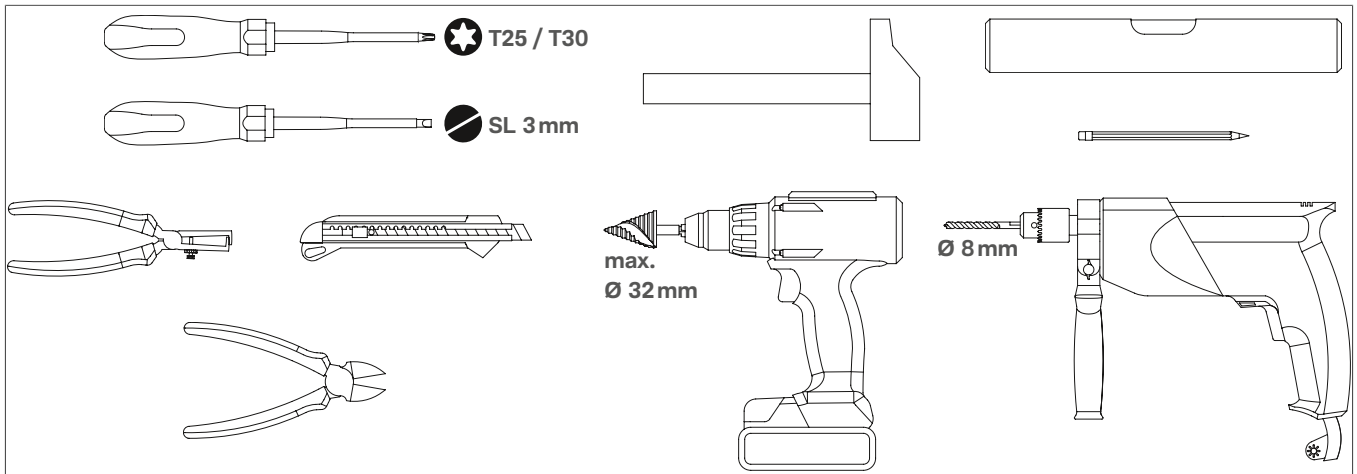



# Overview of the device

## Internal view of the device

- ① Mode 3 type T2S connection socket
- ② Supply terminal block
- ③ Slots for optional cards
- ④ Cable entry sleeve
- ⑤ Securing the cables

### Charging station base

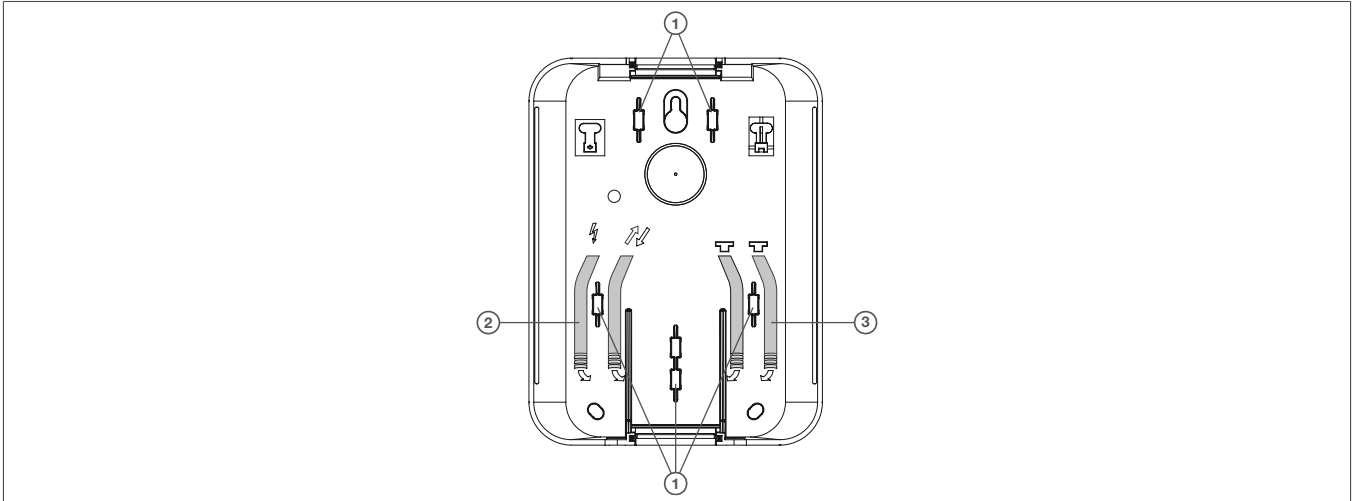

- ① Securing the cables
- ② Sleeve for power supply cable and input/output cables (optional)
- ③ Cable inlets and outlets for optional cards

### Label

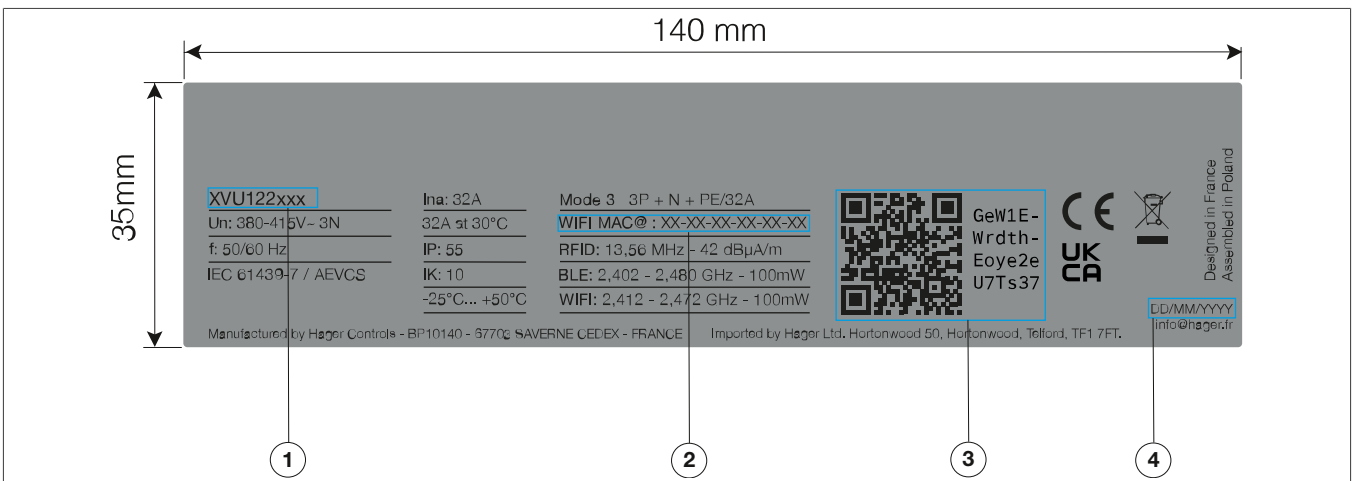

- ① Product reference - Variable field
- ② Mac Address - Variable field
- ③ QR code - Variable field
- ④ Manufacturing date- Variable field

## 5 Installation



### Danger

Danger of death by electric shock.

Contact with live parts can cause death by electric shock.

- Before working on the device, unlock all the corresponding circuit breakers, check that they are voltage-free and secure them before restarting the device.
- Cover the nearby conductive parts.



### Warning

Risk of fire due to device overload.

If the power cable is not properly dimensioned, there is a risk of fire due to device overload.

- Prepare the power cable according to the technical specifications of the device.

The charging station has been designed for indoor and outdoor use. It is therefore necessary to comply with the installation conditions.

- Do not install the charging station in an explosion-hazard area (EX environment), or in premises where ammonia is present.
- Do not install the charging station in a passageway area to avoid any risk of tripping on the charging cable.
- The charging station must not be exposed to a water jet (wash station, pressure washer, garden hose)
- The charging station must be protected, as far as possible, from direct sunlight to avoid overheating and visual degradation of the plastic components.
- The power supply line of the charging station must be dimensioned according to the technical characteristics of the device and installed in compliance with the installation requirements in force.

### 5.1 Protective device requirements

- Each individual charging station shall be protected by a separate RCD with a rated RCD of 30 mA.
- No other load should be connected to this circuit.
- The protective device shall cut off all phases, including the neutral conductor. This charging station has a built-in protection of 6 mA DC and is therefore compatible with type A and F residual-current devices.

#### Dimensioning of the protective device

The charging terminal must be protected by a 40 A circuit breaker curve B or C with the appropriate breaking capacity for the installation.

The power supply to the charging station must not be able to supply more than 6 kA in the event of a short circuit.

Dimension the devices according to the information on the rating plate, the technical specifications and the setting dial of the charging station.

$$I_{(\text{setting dial})} \leq I_{(\text{protective device})} \leq I_{(\text{power cable})} \leq I_{(\text{nominal current})}$$

- Residual current circuit breakers (RCBO) 3P+N 6kA C-40A 30mA A Class.

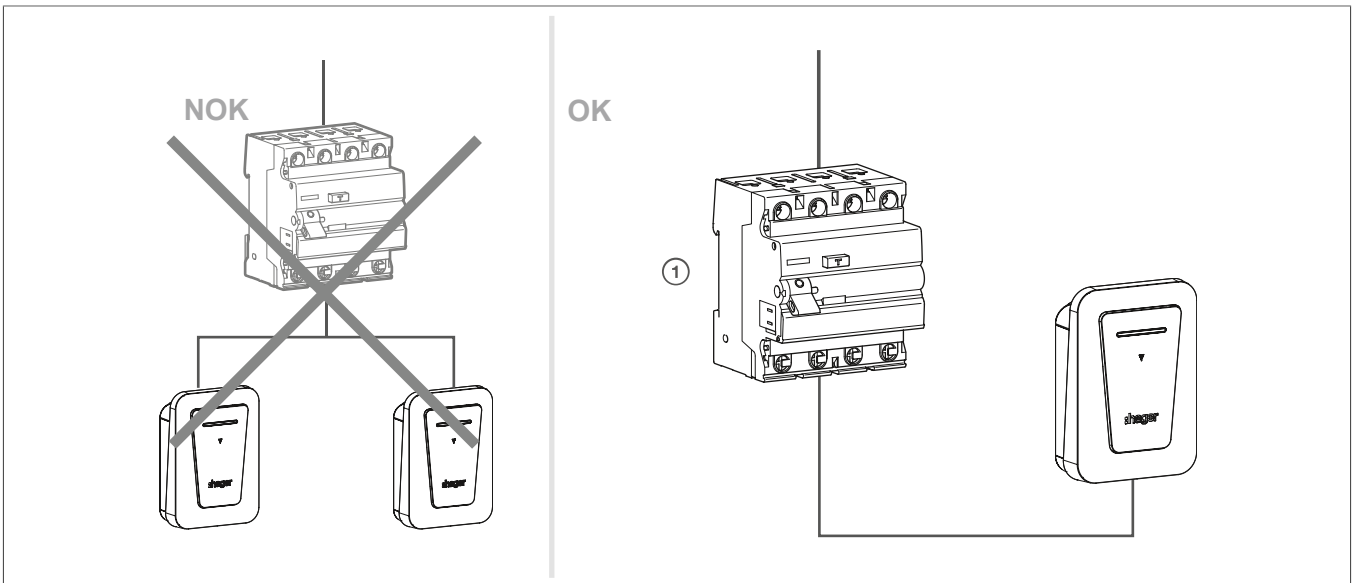

① 3P+N 6kA C-40A 30mA A Class

**Earth resistance and neutral systems allowed**

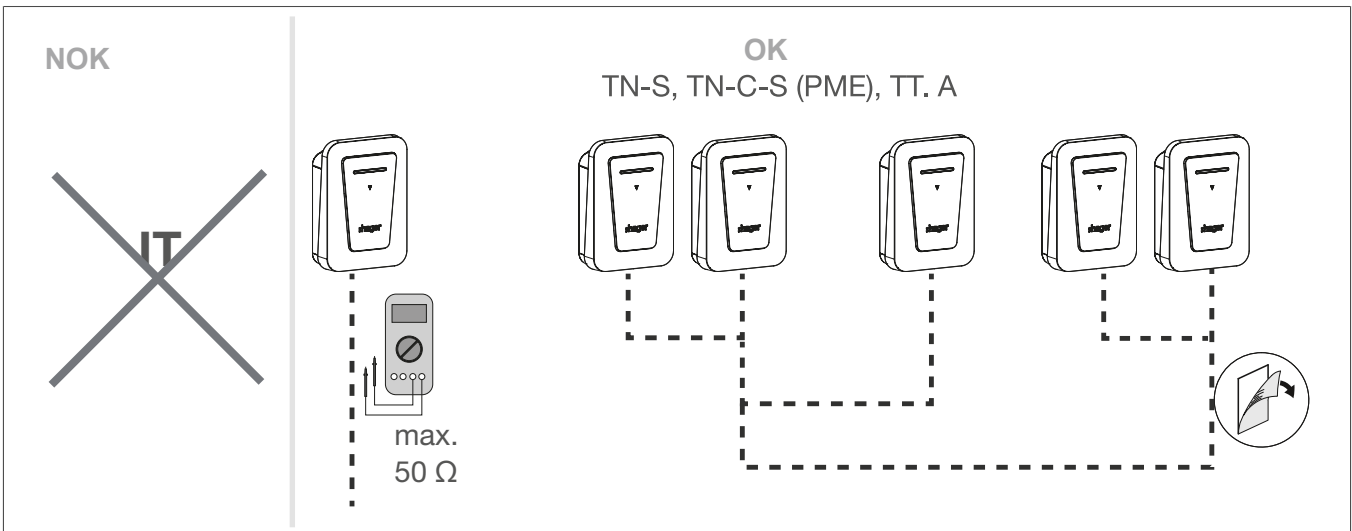

**Caution**

According to EN IEC 61851-1, this charging station incorporates a DC-CDC compliant with IEC 62955. If a DC component > 6 mA is detected at the fault current, this DC-CDC acts on the embedded power relays of the charging station, which automatically cut off the power supply to the charge point. This 6 mA DC detection device eliminates the need for a Type B residual current device. All circuits of the building must be installed in completely the same structure (from the electrical point of view).

**Information**

A maximum of 5 charging stations can be connected to one earth terminal, with a recommended earth resistance of max. 50 Ω.

**Danger**

Damage to the charging station or electric vehicle during the charging process due to high voltages.

Transient overvoltages due to atmospheric phenomena or switching can destroy electronic components.

- Install overvoltage protection units upstream of the electronic household consumption meter. Upon the dimensioning step, take local conditions into account.

Provide surge protection devices for charging stations in public and semi-public areas, in accordance with the local standards in force.

## 5.2 Pen fault detection

In electric vehicle charging installations in the UK and Ireland, protection against PEN faults is a key regulatory requirement. The PME/TN-C-S low-voltage networks, which are widely used in the UK and Ireland, combine the neutral and protective conductors into a single conductor known as the PEN. If the pen breaks, dangerous voltages may appear on the metal grounds of the terminal or vehicle, exposing the user to a serious risk of electric shock. BS 7671:2018 + A2:2022 therefore require the use of a device capable of identifying these faults and simultaneously disconnecting L, N and PE from the vehicle in the event of a fault.



This charging station is compatible with IET 01:2024, which defines the operating requirements of pen fault detection devices for domestic and similar charging installations. This compliance ensures adequate protection in the event of a pen driver abnormality, in accordance with the technical requirements published by the IET.

## 6 Mounting the charging station

### 6.1 Preparatory work



#### Danger

Danger of death by electric shock.

Contact with live parts can cause death by electric shock.

- Before working on the device, unlock all the corresponding circuit breakers, check that they are voltfree and secure them before restarting the device.
- Cover the nearby conductive parts.



#### Danger

Risk of injury due to falling/tipping of the charging station

Use appropriate fixings to prevent the charging station from falling and causing injuries.

- Adapt the installation accessories to the requested conditions at the installation location. The fixings supplied are suitable for concrete and masonry.



#### Information

Upon delivery, the front panel and the mounting bracket are not screwed in.

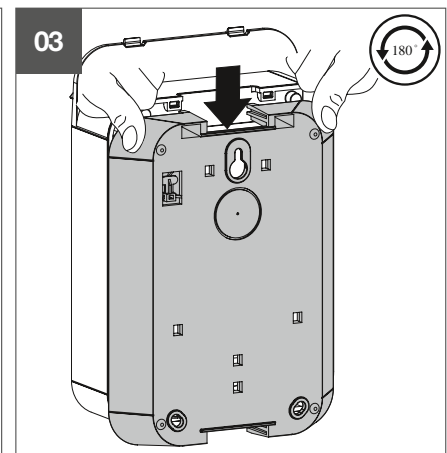
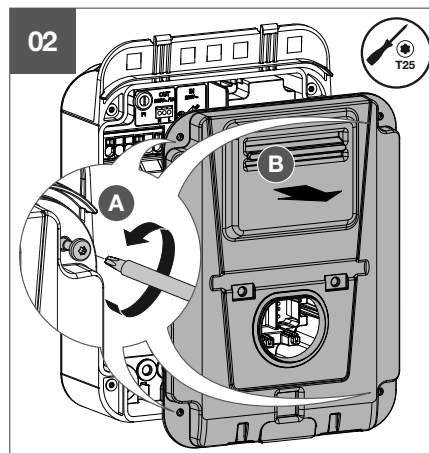
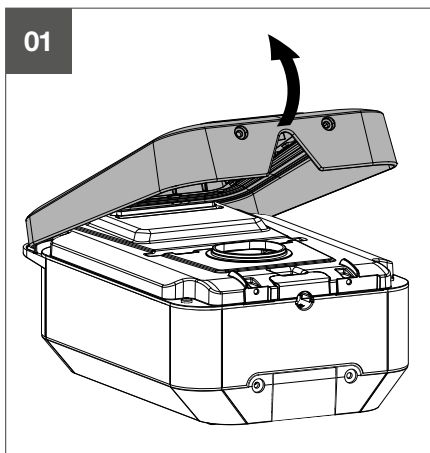

#### Prerequisites

Mounting can be done on a wall, column or pole. Horizontal installation on the ceiling or floor is prohibited.

If the temperature difference between the storage and the installation site is too high, the charging station must be brought to ambient temperature

Before mounting the charging station, make sure that all of the cables are present:

- 3 L + N + Earth for a three-phase terminal cable cross-section:
  - The minimum cable cross-section for a charging station with a 16 A power supply is 2.5 mm<sup>2</sup>. It is absolutely necessary to take into account the maximum admissible length of cable.
  - The maximum cross-section of the power conductors is 10 mm<sup>2</sup> for multiwire and single-stranded conductors.

## 6.2 Wall mounting

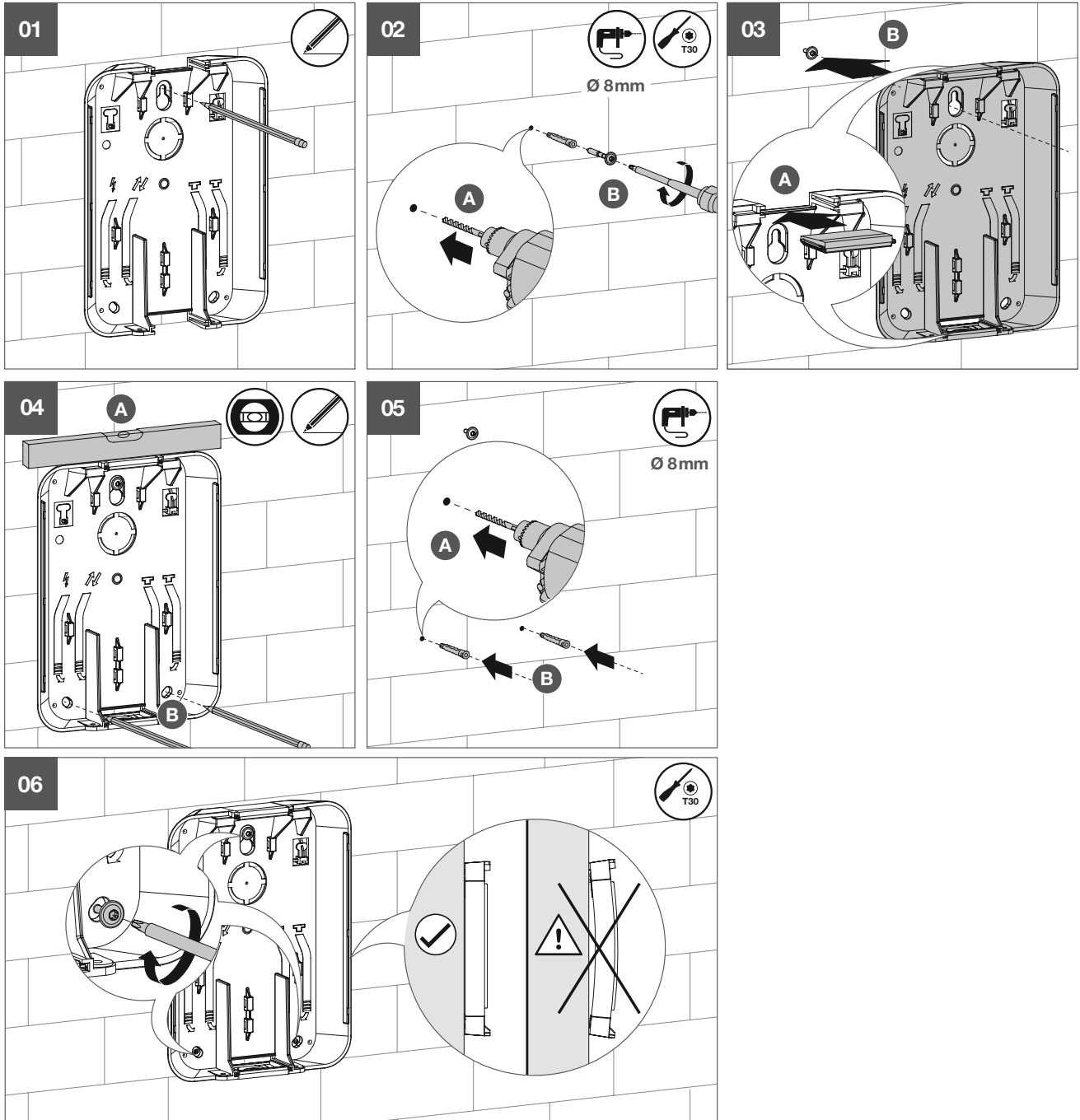

# Mounting the charging station

## Wall mounting

The connecting cables can enter the charging station from the rear, the top, or from below.

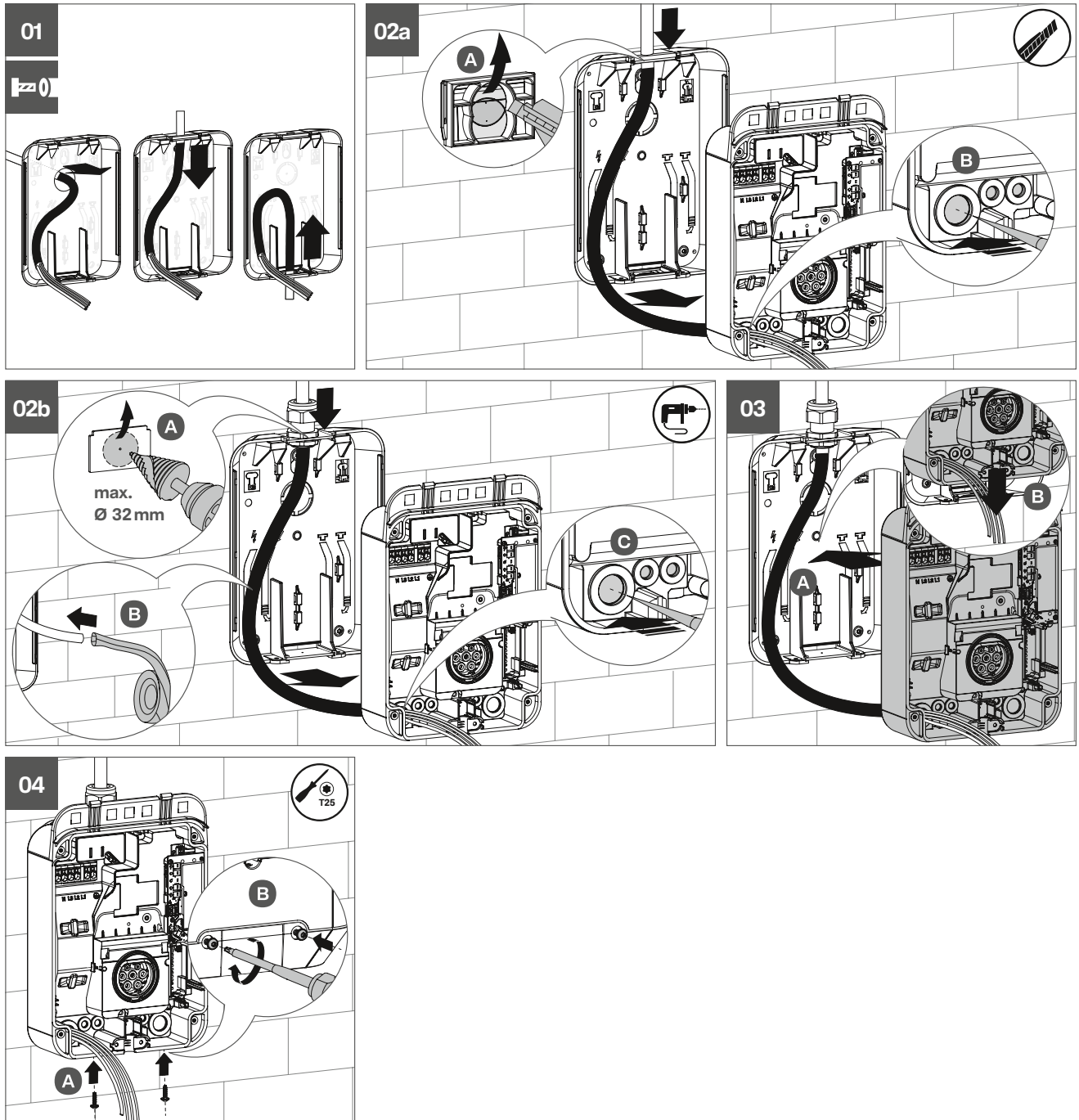

## 7 Electrical connection



### Danger

Danger of death by electric shock.

Contact with live parts can cause death by electric shock.

- Before working on the device, unlock all the corresponding circuit breakers, check that they are voltfree and secure them before restarting the device.
- Cover the nearby conductive parts.



### Caution

Special attention must be paid to the phase order when connecting to the terminal block (marked L3-L2-L1-N).

A critical error occurs if the phase order is not respected and the status LED lights up red continuously. This protection ensures correctly measured and calculated power consumption data.

Phase rotations are allowed but must be configured using the mobile app.

### 7.1 Connection to the power terminal block

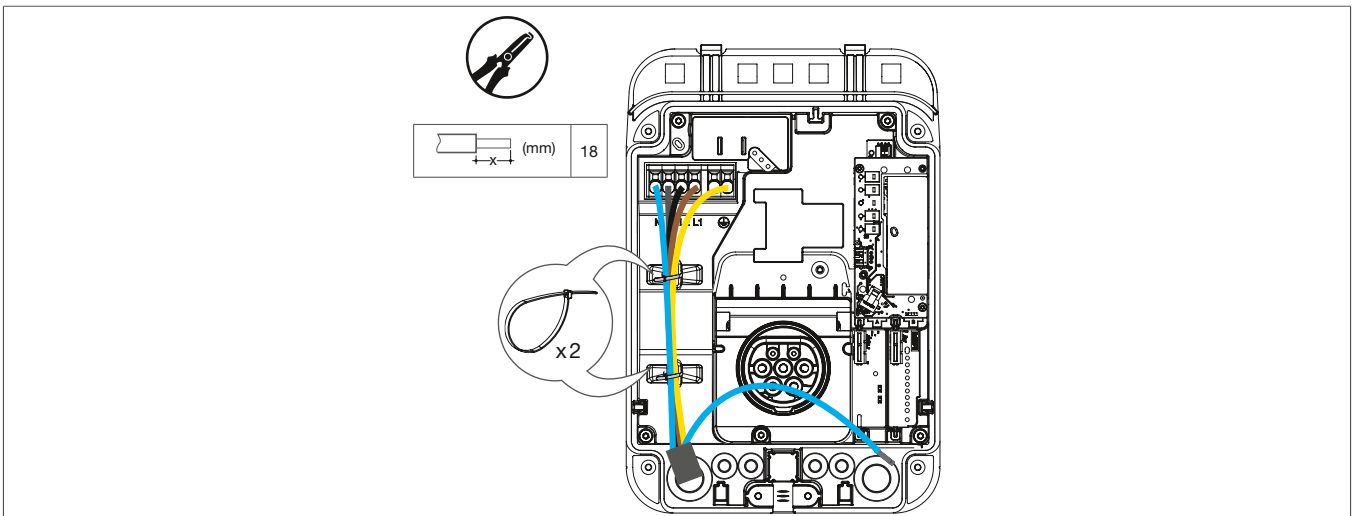

The power supply terminal block is a spring terminal block.

The admissible cable cross-sections are:

- Rigid (min-max): 0.75 mm<sup>2</sup>...10 mm<sup>2</sup>
- Flexible (min-max): 0.75 mm<sup>2</sup>...10 mm<sup>2</sup>
- Flexible with end piece (min-max): 0.75 mm<sup>2</sup>...10 mm<sup>2</sup>

Conductors must be stripped over a length of 18 mm

## 7.2 Connection of the metering board with CT

The metering card is a module intended to be integrated in charging stations for electric vehicles.

It provides real-time information about the electrical power consumption to the charging station, in order to manage the dynamic charge of the vehicle (adapting the vehicle's charge current according to the power consumption of the building).

The **XVA330** (three-phase version) is intended for 3-phase (400 V) installations. It uses 3 current transformers (one per phase: L1, L2, L3). This version is suitable for tertiary buildings, industrial buildings, or domestic installations requiring high power.

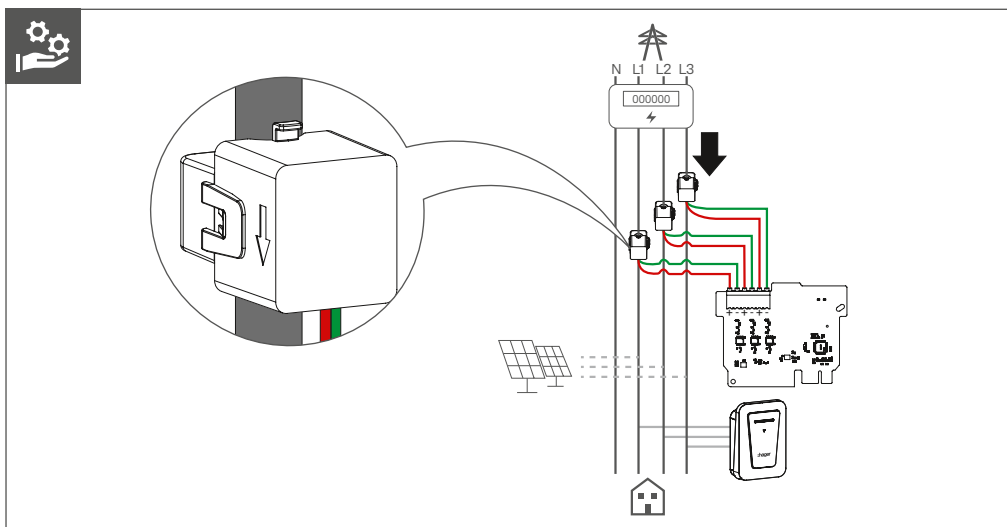

### Description of the card

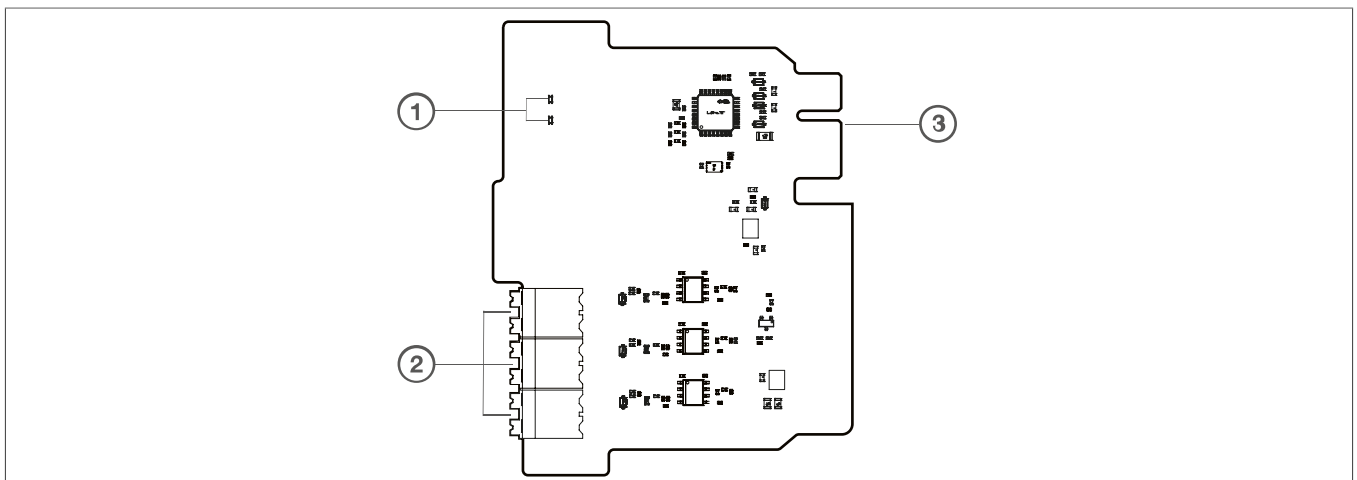

- ① Board status LEDs
- ② Link connector
- ③ Connector Card/charging station

**Function**

Regardless of the model, the option board allows:

- Accurate measurement of currents via current transformers.
- Dynamic load management to prevent power overruns.
- Solar optimization, by automatically adapting the load according to the available photovoltaic production.

**Installing the TC card**

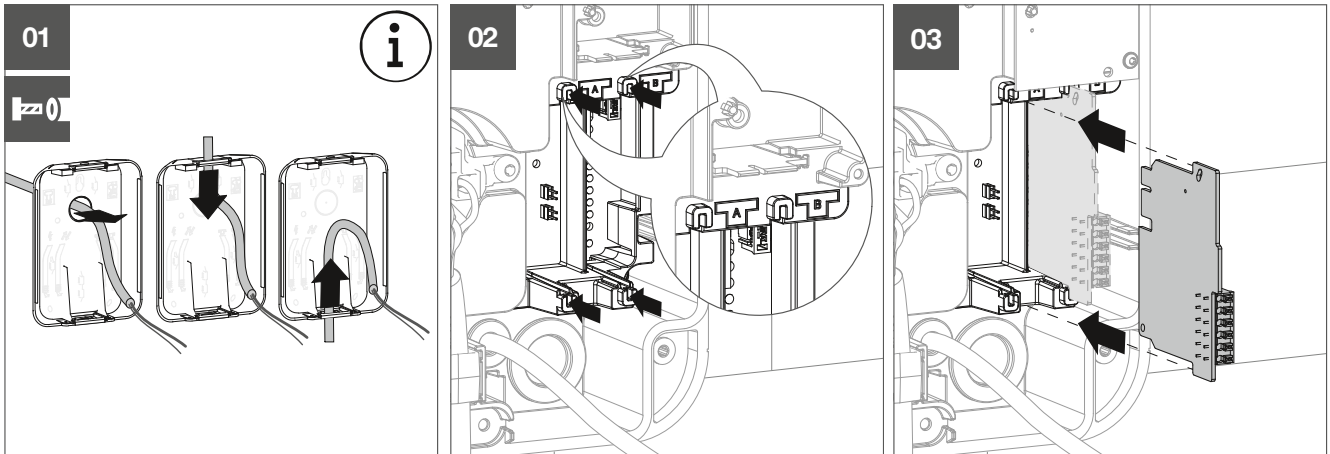

**Information**

The remaining cable should be about 60 cm long to allow connection to the optional board.  
 The optional board can be installed either in slot A or slot B.

**Connecting the board**

- Connection of current transformers to measure the current of your electrical installation.

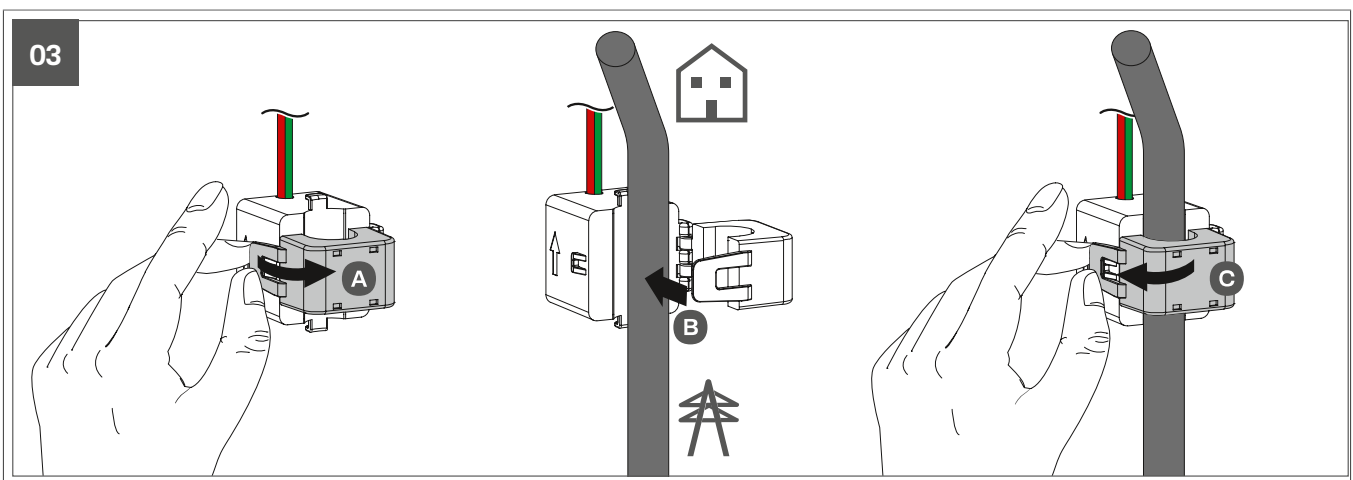

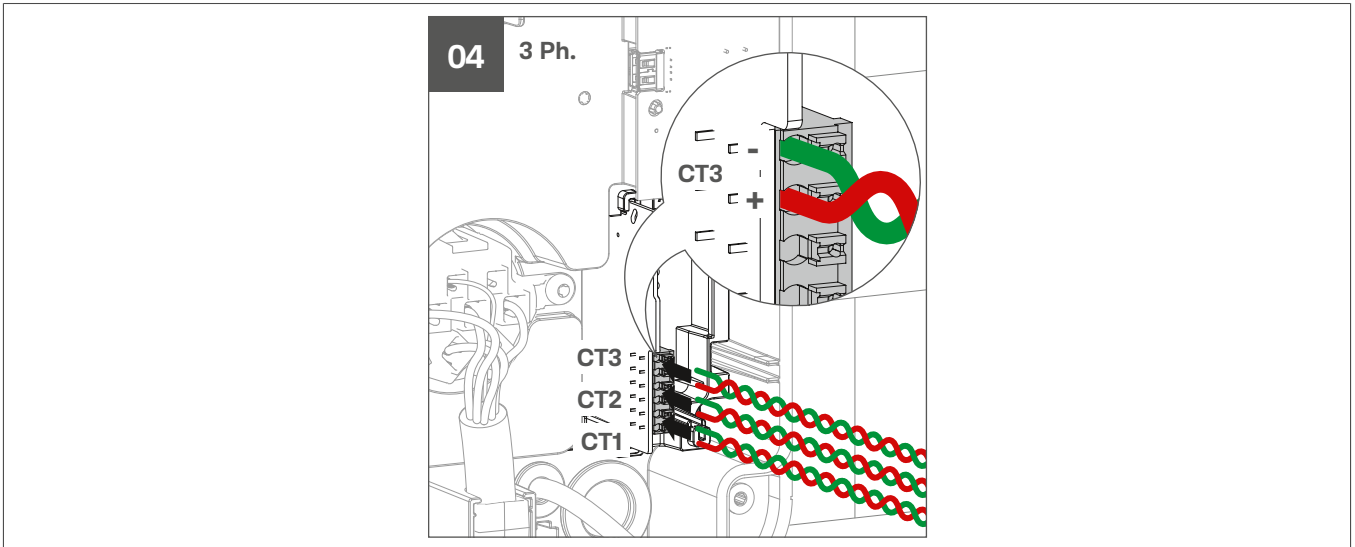

**Information**  
 For direct cabling installation, the cables of the current transformers can be shortened in order to adjust their length and limit measurement disturbances.

**Information**  
 For CT cabling with extension cord not included, it is recommended to use Cat5e FTP Ethernet cable or higher, dedicating one twisted pair per CT to ensure signal integrity.  
 The length of cabling can be extended beyond the original 5 m, up to a maximum of 100 m when an appropriate extension cord is used.  
 As with all measurement wiring, conductors must be routed in separate conduits from the main voltage to minimize electromagnetic interference and ensure accurate measurements.

**Meaning of the card status LED**

The metering board is equipped with LEDs indicating its operating status. However, these LEDs are only active when the cover is removed.

- The charging station should be switched on
- Remove the cover

After about 10 seconds, the LED indicates the operating status of the card.

LED status	Meaning
	Card in operation
	No communication

**Parameterization of the metering board**

Once the card has been installed in the charging station, it can be configured using the **Hager charge** application.

This application, available for download, automatically detects the terminal equipped with the card, accesses the measurement parameters and loads the dynamic management and solar optimization options.

## 8 Settings

### 8.1 Operating current and connection type

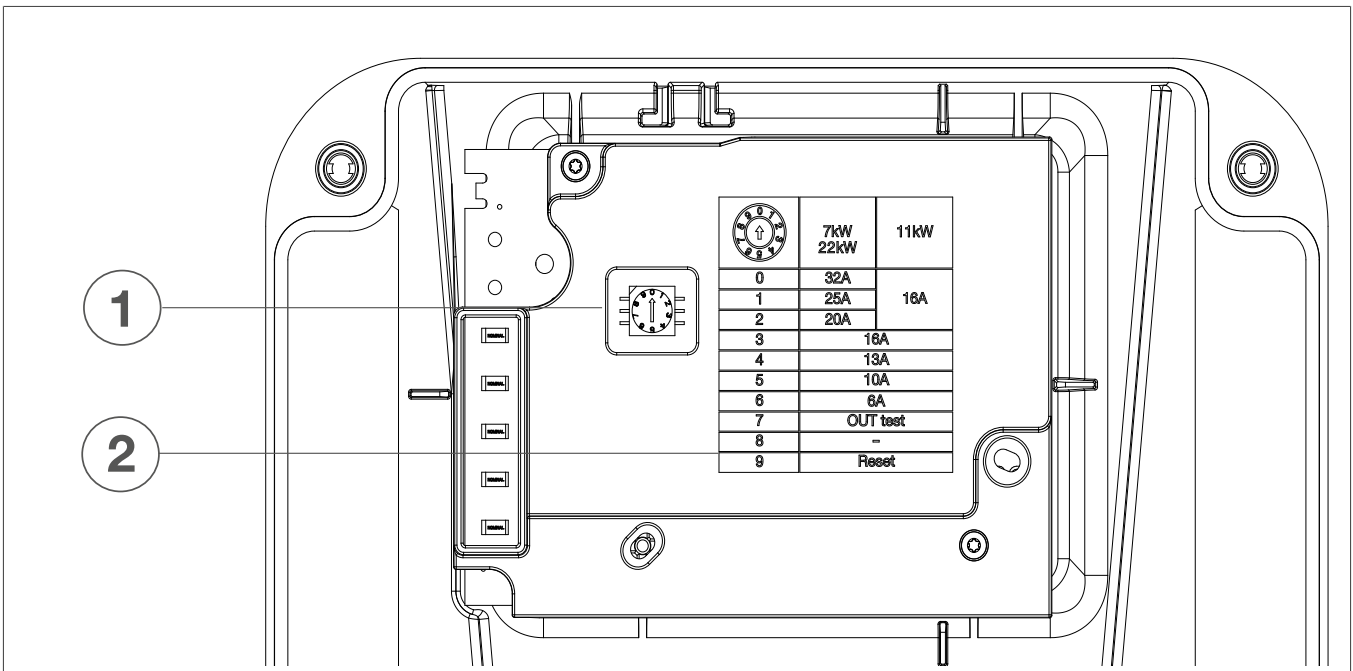

- ① Setting dial
- ② Settings Table

Note the maximum operating current setting on the device:

- Peel off the sticker corresponding to the adjustment made
- Attach this sticker to the charging station near the rating plate.

### 8.2 Reset from the charging station

This procedure resets the charging station without using the application.



#### Information

This procedure will delete :

- the connection with paired phones
- the connection to paired badges and their parameters

#### Reset procedure:

- ① Turn off the charging station for 20 seconds.  
When doing so, take the RCD and all circuit breakers into account.
- ② Set the dial to 9.
- ③ Close the cover and turn on the charging station again.  
The charging station status LED turns red. The charging station is being reset. This is effective as soon as the status LED flashes red.
- ④ Turn off the charging station for 3 minutes.  
When doing so, take the RCD and all circuit breakers into account.

- 5 Open the charging station cover and set the dial between 0 and 6.
- 6 Close the cover and turn on the charging station.

## 9 Final assembling



### Danger

Danger of death by electric shock.

Contact with live parts can cause death by electric shock.

- Do not switch on the charging station until the front of the charging station is locked.

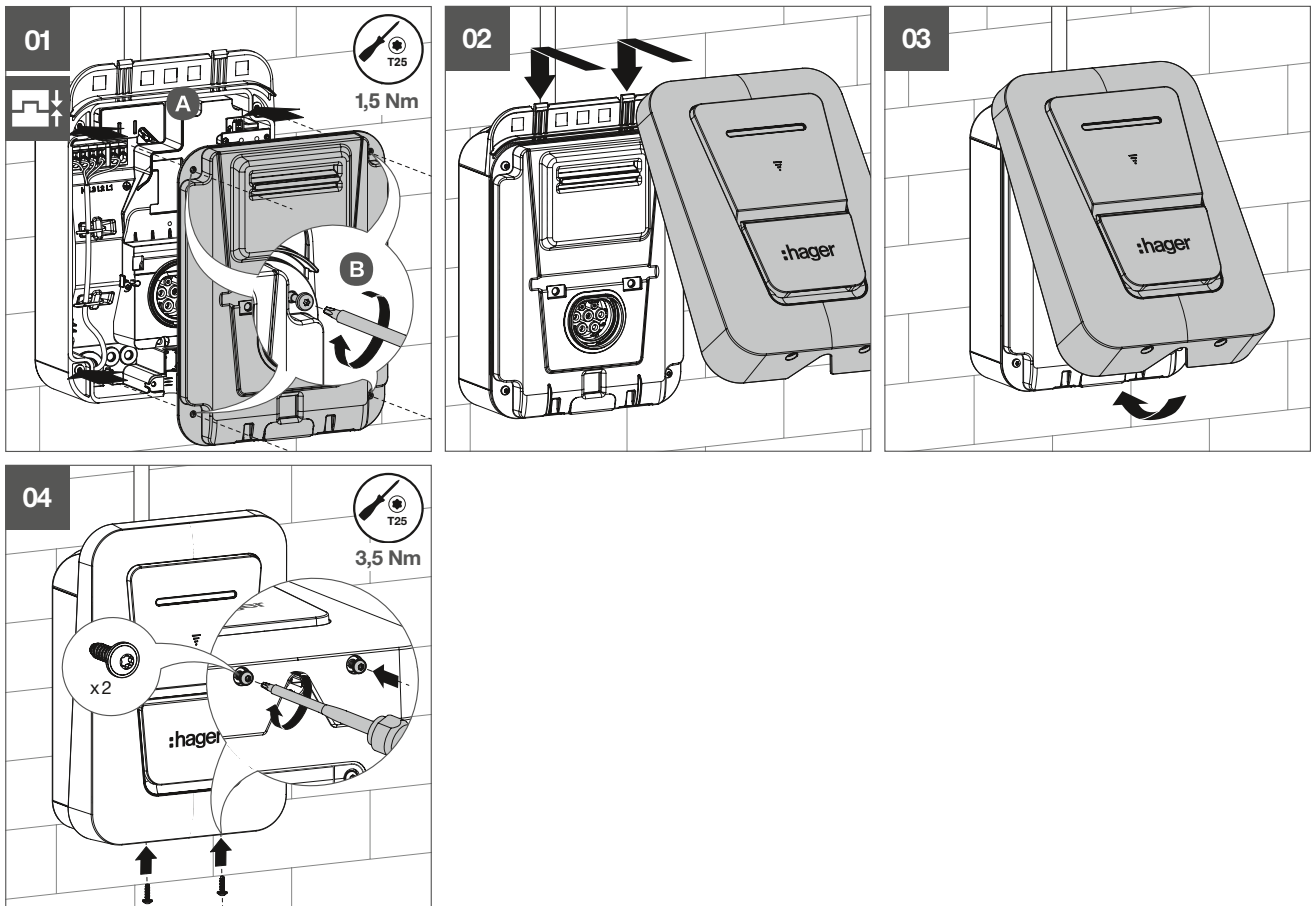

### Information

IP55 protection could be lost:

- If the tightening torque is not respected (see tightening torque picture 1)

## 10 Commissioning



### Information

Before commissioning, check that the charging station is not connected to the electric vehicle.

After the charging station is switched on for the first time, initialization is complete when the LED indicator strip remains solid green.

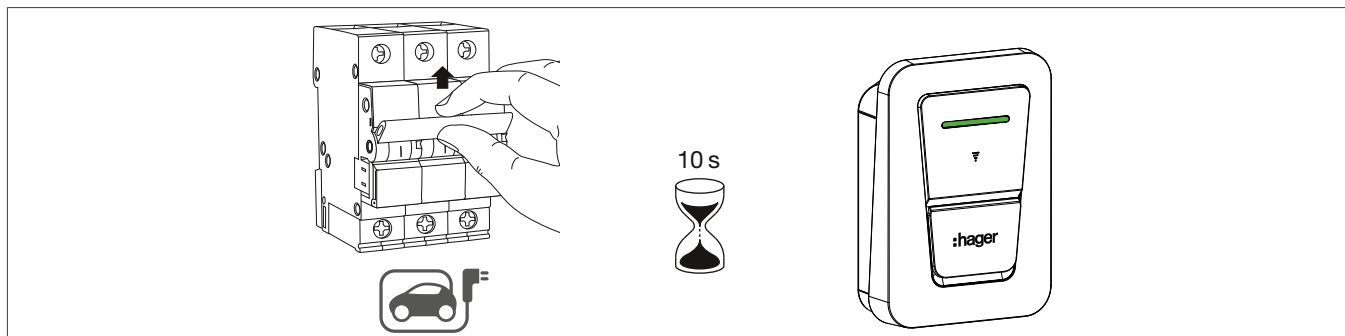

The charging station is now functional. It can be used to recharge an electric vehicle.

## 11 Advanced Configuration

It is also possible to configure the terminal using the Hager charge application, which is available for download. This application allows you to activate and configure the Wi-Fi interface of the charging station to ensure its network access. Once connected to the base station via Bluetooth, simply follow the instructions in Hager charge to finalize the necessary settings.

The charging station shown is compatible with the Open Charge Point Protocol (OCPP) in version 1.6 JSON, guaranteeing complete interoperability with supervision systems compliant with this open standard.

The Monta application is a mobile platform that allows the user to configure, manage and supervise a compatible charging station via the OCPP protocol. It is used to connect the terminal to the network, to configure its operation and to integrate it into the user account for control or supervision. Monta is available on mobile store and can be used once installed following the guided steps on the screen.

### 11.1 Configuration via the Hager charge application

#### 11.1.1 Pairing

Download the free Hager Charge app to your mobile device.



Hager Charge



#### Information

The Bluetooth function  and the location function of your mobile phone must be activated.

- 1 Start the application.
- 2 Accept the general terms and conditions of use.
- 3 Click on 'Next'.
- 4 Click to 'Activate the Bluetooth function'.
- 5 Click on 'Start pairing'.
- 6 Position the pairing badge on the front of the charging station.
- 7 Remove the badge when the indicator on the front panel flashes blue from left to right (this action takes approximately 7 seconds).
- 8 In the application, confirm by clicking the button.  
The application performs a scan and displays the device identified.
- 9 Enter device name (optional).
- 10 Click on 'Pair with this charging station'.
- 11 Confirm by clicking 'Pair'.

When the pairing process is complete, the following screen appears:



### 11.1.2 Configuration of the communication interface

Once the charging station is installed, it is necessary to configure the settings according to the available networks.

On your smartphone:

- 1 Launch the **Hager Charge** application.
- 2 Go to the **General settings** page in the **charging station settings**.

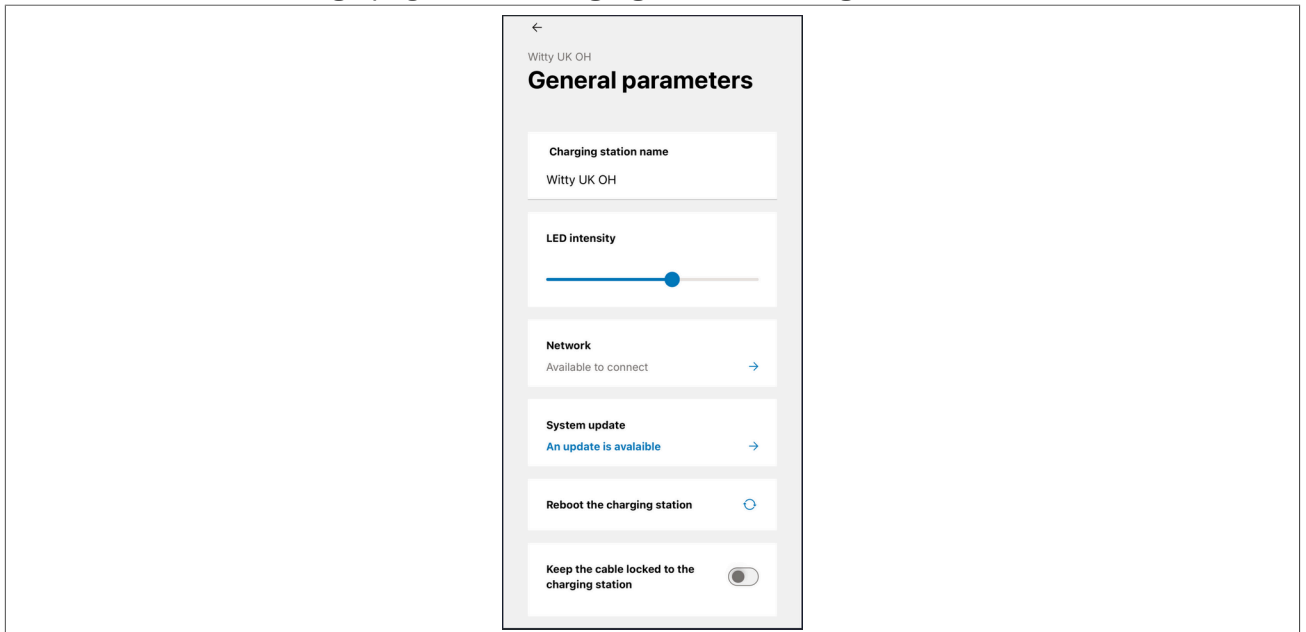

- 3 Click on **Network** to define the settings according to the type of network.

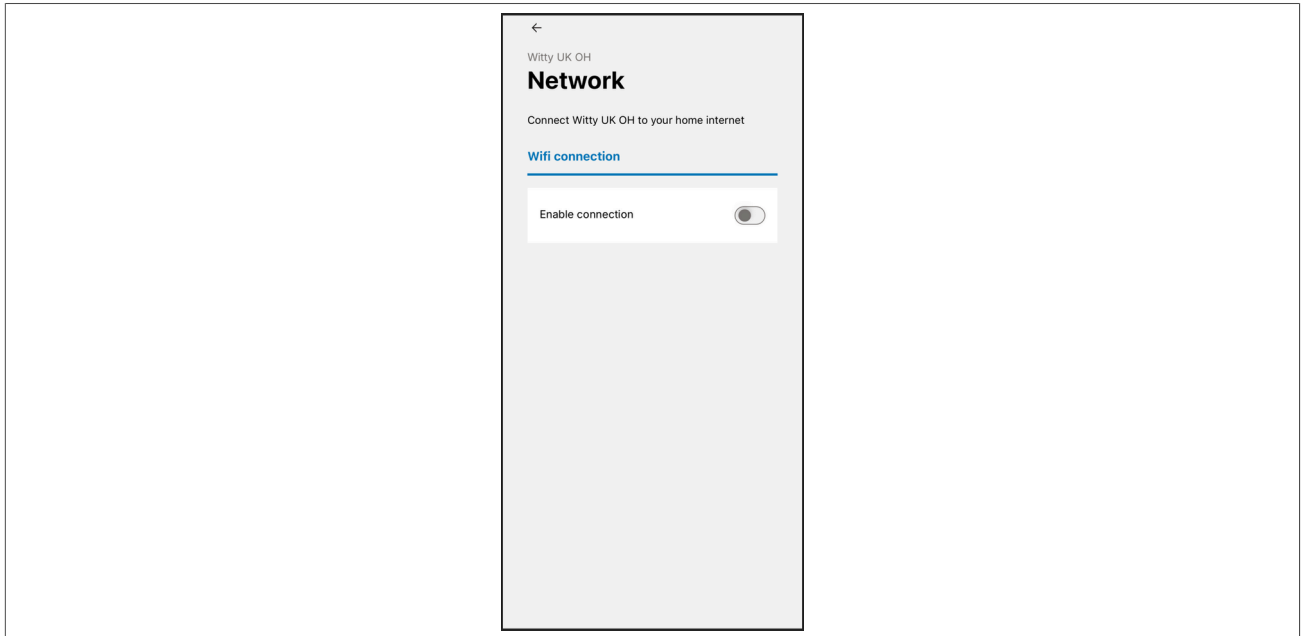

- 4 Select the type of network: **Wired** or **Wireless (Wi-Fi)**

### Wireless Networks (Wi-Fi)

The Wi-Fi network allows a wireless radio connection between the charging station and the router. There are 2 ways to choose the Wi-Fi network (depending on the router model):

- By scanning the QR code present on the Wi-Fi router
  - Click on the blue **Wi-Fi QR Code Scanner** button
  - Scan the QR Code located on the Wi-Fi router
- By manually adding Wi-Fi credentials
  - Click **Manually Add Wi-Fi ID**

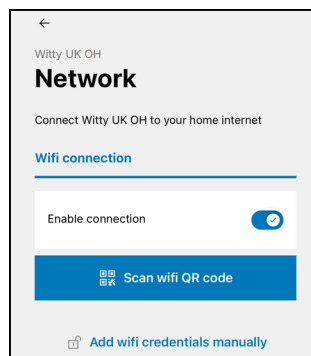

- Enter the network name (SSID)
- Enter the password

By default, the charging station is configured in Dynamic Host Configuration Protocol (DHCP), which automatically assigns an IP address from the router or switch.

If you need to configure an IP manually:

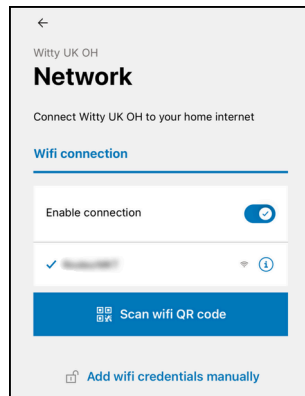

- Click **i** to access the settings

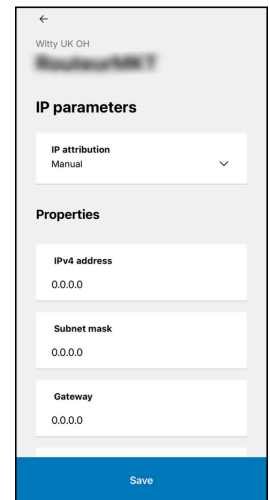
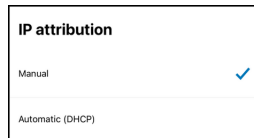
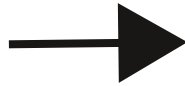
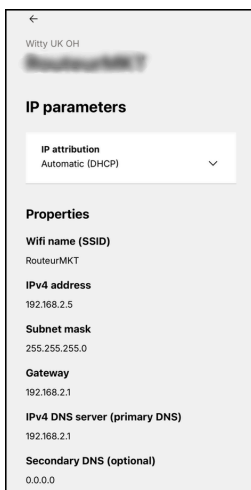

- In **IP Assignment**, select **Manual**.
- Change the settings according to your network.
- Click **Save** to save the new settings

## 11.2 Configuration via Monta

After electrical connection and switching on, the terminal must be configured using the Monta application, compatible with Hager terminals supporting OCPP 1.6-j.

### Downloading the Monta application

The charging station has a QR access code affixed to its outer envelope.

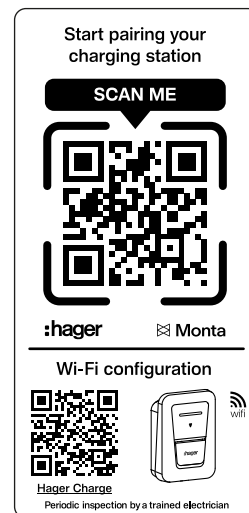
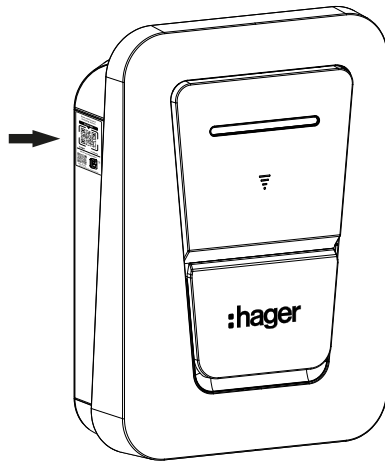

By scanning it with a smartphone, the user is redirected to the download page of the **Monta charge** app, available on the Android and iOS stores. This application allows you to connect the terminal, configure it and activate the associated services (management, monitoring, advanced configuration).

## 12 Charging station operation

### 12.1 Operation with a badge

Access control can be configured on the charging station. To do so, a valid RFID badge for the charging station is needed.

On first use, the first badge presented automatically becomes the administrative badge of the charging station.

This badge is specific to this terminal only and allows configuration operations to be performed.



#### Attention

Unauthorized pairing of badges with the charging station can result in security risks. Any unauthorized person could gain access to the charging station and its features. In order to ensure an adequate level of safety, it is essential to observe the following guidelines:

- Set up the charging station immediately after initialization.
- Pair the first badge as an administrative badge.
- Keep the administrative badge in a safe place, as it allows access to the station's configuration and management functions.

After connecting the charging station plug to the vehicle, the signal strip flashes (green and white) while waiting for the badge.

- Put the badge close to the logo on the front of the charging station.



If the badge is valid, the signal strip flashes blue. Charging begins.

If the badge is not valid, the warning strip flashes red.



Once the administrative badge has been paired with the charging station, only it can be used to reconfigure the charging station.



The same RFID tag can be paired with multiple charging stations, provided that:

- the terminal concerned is not already paired with another administrative badge
- the pairing procedure is performed separately on each terminal.

## 12.2 Operation with the MONTA app

The MONTA app allows users to start, control charging, monitor consumption, schedule sessions, and access private or public charging networks, all from their smartphone. Before to start commissioning the charger should be installed, connected to network and powered – on.

- Start to scan the QR-code to load the Monta Charge app
- On Monta : Create a Monta account (with email address or telephone number if not yet done)
- Complete manually all information's missing
- Connect the charging cable to the charging station and then to your electric vehicle.
- Open the MONTA app.
- Select the corresponding charging station (via the map or by entering its number).
- Start the charging session by pressing **Start charging** in the application.

Charging starts automatically, and its status can be monitored in real time in the MONTA app.

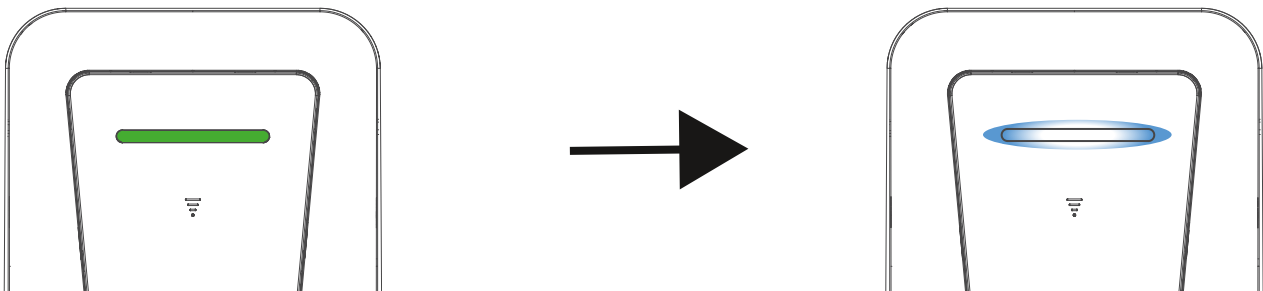

The signal strip flashes blue when charging.

- To stop the charging session, select **Stop charging** in the application.
- Disconnect the charging cable from the car.

## 13 Charging an electric vehicle

### 13.1 Preparation for a charging session

The charging station is ready to operate when the LED signal strip is green.

- Connecting the charging cable to the vehicle
- Connect the charging cable to the charging socket of the charging station.

The vehicle is ready to be charged and the charging process can start.





### 13.2 Stopping a charging session

Charging can be stopped:

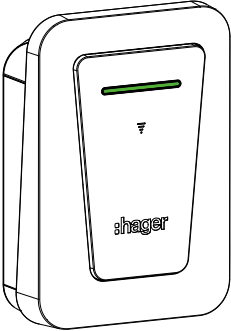

- Through the vehicle (please refer to your vehicle’s user manual for further information).
- By holding an authorised RFID badge near the logo  on the front of the charging point.
- Using the **MONTA** app.

### 13.3 LED light strip

**Operation:**

		Charging Station Ready
		Waiting for vehicle authorisation or waiting for sufficient power on the network
		Waiting for user authorisation
		Charging in progress

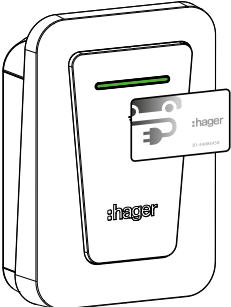
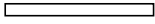
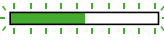
**Operation with the badge:**

	<1s		RFID badge reading
	3s< 6s		Charging to forcing or returning to default mode
	6s<		Pairing mode

**Fault display:**



**Caution**

Damage to the charging station due to a critical error.

- If a critical error is indicated by a solid red light, turn off the charging station for 2 minutes to clear the error.

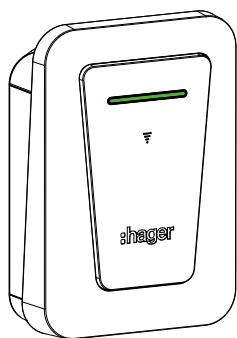

Charging station faulty

Pen fault detected

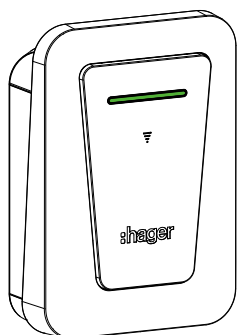

Pen fault detected



Signaling a pen fault detected, **user action** is required to acknowledge the fault



Information

The **user action** consists of disconnecting the vehicle from the charging station.

## 14 Maintenance



### **Danger**

Danger of death by electric shock.

Contact with live parts can cause death by electric shock.

- Before working on the device, switch off all relevant circuit breakers.
- Cover the nearby conductive parts.
- Before carrying out any work on the device, disconnect the charging cable from the charging station and the electric vehicle

Maintenance work must be carried out at regular intervals, taking into account the age and condition of the device, environmental factors as well as usage levels.

Semi-annual maintenance by operator/end customer (recommendation)

- Check that there is no damage to the outside of the unit. In case of damage, take the unit out of service immediately and contact a qualified electrician.
- Check that the electrical switching and safety devices in the secondary distribution system are functioning perfectly and have no visible defects.

## 15 Appendix

### 15.1 Technical specifications



#### Information

This document is not contractually binding and is subject to change without notice

#### Environmental conditions

Operating temperature	-25°C to +50°C
Storage temperature	-35°C to +70°C
Relative humidity	5% to 95%
Protection	IP 55 - IK 10
Maximum operating altitude	2000 m
Degree of contamination	3
Shock voltage $U_{imp}$	4 kV
Rated breaking capacity $I_{cn}$ AC according to IEC60898-1	6 kA

#### Electrical characteristics

Voltage $U_e$	380 V~ / 415 V~ -15 % / +10 %
Nominal insulation voltage $U_i$	250 V~ / 500 V~
Frequency of use $f_n$	50/60 Hz +/- 1%
Maximum charging current / power mode 3	32 A - 22 kW
Electrical protection class	Class I (protective earth)
Overvoltage category	III
Earth connection diagram	TN-S, TN-C-S, TT
Upstream protection	RCBO C40 6000 3 (according to IEC60898-1)
Power consumption at idle	5 W
Conductor cross-section (rigid)	2.5 - 10 mm <sup>2</sup>
Conductor cross-section (flexible)	2.5 - 10 mm <sup>2</sup>
Integrated residual-current protection	6 mA $\overline{\text{=}}$

#### Mechanical properties

Weight	3.8 kg
Height	368 mm
Width	255 mm
Depth	150 mm

#### Packaging specifications

Weight	7.9 kg
Height	595 mm
Width	270 mm
Depth	300 mm

#### Classification

Power input	power supply system for electric vehicles (EV) permanently connected to alternating current power supply
Power output	alternating current power supply system for EV
Environmental and operating conditions	for indoor and outdoor use
Location	for open or restricted access areas
Mounting type	surface mount for wall, stand, fixed post, column and conduit mounting. DO NOT INSTALL horizontally on ground or ceiling
Charging mode	mode 3 via T2S socket
Adapter (in accordance with the standard EN IEC 61851-1)	No plug adapter may be used between the charging station and the charging cable or between the charging cable and the car. Adapters may only be used in the charging socket of

**Classification**

	the electric vehicle if they have been specially designed and approved for this purpose by the vehicle or charging station manufacturer and comply with applicable national standards. These adapters must comply with all standards applicable to the adapter parts that are connected to the charging cable plug or the charging socket of the electric vehicle. These specific conditions of use must be indicated on the adapter, e.g. IEC 62196 series. The use of adapters that change the charging mode of the charging station is prohibited.
Cable length and cable extension	No extension of the charging cable is permitted; the charging cable must be in one piece and no longer than 7.5 m

**RFID**

Frequency band	13.553 - 13.56 MHz
Max. radiated power	42 dBμA/m (at 13.56 MHz)

**Bluetooth**

Frequency band	2.402 - 2.480 GHz
Max. radiated power	100 mW

**Wi-Fi**

Frequency band	2.412 - 2.472 GHz
Max. radiated power	100 mW

## 15.2 Identification of compatible vehicles in accordance with EN 17186

Alternating current	EN 62196-2	Type 2	Plug Power socket base	< 480 V RMS	
---------------------	------------	--------	------------------------	-------------	---

## 15.3 CE+UKCA Declaration of Conformity

Hager hereby declares that the charging station products with reference XVU122SCT-MO comply with the RED 2014/53/EU directive and SI 2017/1206 Radio Equipment Regulations 2017 (as amended). The declarations may be viewed at: [www.hagergroup.net](http://www.hagergroup.net).

## 15.4 Disposal of the charging station

**Disposal note**



Correct disposal of this product (electrical waste).

**(Applicable in the European Union and other European countries with separate collection systems).**

This marking shown on the product or its documentation indicates that it should not be disposed of with other household waste at the end of its working life. To prevent possible harm to the environment or human health from uncontrolled waste disposal, please separate this device from other types of waste. Recycle the device responsibly to promote the sustainable reuse of material resources.

Household users should contact either the dealer where they purchased this product, or their local government office, for details of where and how they can take this device for environmentally safe disposal.

Commercial users should contact their supplier and check the terms and conditions of the purchase contract. This product should not be mixed with other commercial waste for disposal.

## 15.5 Warranty

We reserve the right to make **technical or design changes** to the product as part of its continuous improvement.

The product is covered by the **legal warranty in force**.

In the event of a warranty claim, please contact **your business partner** .

## 15.6 Software security updates

Hager will provide **software security updates and support for a period of three years** from the date of sale of the product.

These updates are intended to **address** identified **security vulnerabilities** only.

After this period, the provision of security updates is no longer guaranteed.



**Hager LTD**

Hortonwood 50

Telford-TF1 7FT

United Kingdom

T +44 1 952 677 899

F +44 1 952 675 581

info@hager.com

**hager.com**