

Installation instructions

# Energy management

## flow R3 energy storage system

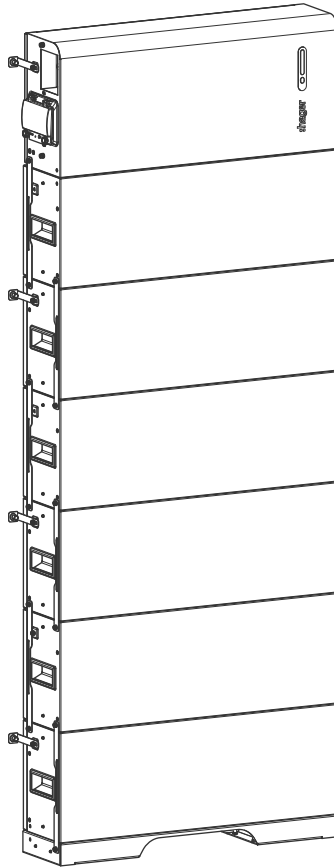

flow R3 energy storage system 6/ 9/ 12 kWh  
**XEM4x0x**

CE

**:hager**

## Legal information

### Legal information

The information contained in these documents is the property of HagerEnergy GmbH. Publication, either in whole or in part, requires written approval.

Internal reproduction, intended for the evaluation of the product or for correct use, is permitted and does not require approval.

### Additional information

The device was developed, produced and tested with special care and using state-of-the-art technology.

HagerEnergy GmbH fulfils the requirements of DIN EN ISO 9001 and proves this through a certified quality management system.

Please obtain the current version of these instructions from the customer portal. Carefully read the instructions. Images in these instructions can deviate from the actual state of production of the device.



For more information on the safe transport of battery modules, please contact us at **+ 49 6842 945 98 00**.

If you have questions, feel free to contact us.

You can find more information on the product and HagerEnergy GmbH on the company website.

HagerEnergy GmbH

Ursula-Flick-Straße 8

D-49076 Osnabrück

Telephone: +49 541 760 268-0

Email: [info@hager.com](mailto:info@hager.com)

Website: [hager.com](http://hager.com)

Portal: [flow.hager.com/documents](http://flow.hager.com/documents) (registration required!)

© 2026 HagerEnergy GmbH. All rights reserved.

This manual applies to the following device:

Device: Battery installation in flow R3

Battery type: DCB-SAHoc

Date and version of these instructions: 2026-03 | Version: A



The instructions of HagerEnergy GmbH are subject to continuous development. The current version of this manual and further information on the use of the product can be downloaded via the QR code shown in the customer portal (registration required!).



<b>1</b>	<b>Battery system components.....</b>	<b>4</b>
1.1	Base plate.....	4
1.2	Battery module DCB-SAHoc.....	6
1.3	Battery management system.....	8
1.4	Scope of delivery.....	10
1.4.1	Accessory pack for battery type DCB-SAHoc.....	10
1.4.2	Communication cable (BE-K1414).....	11
1.4.3	Battery cable (BE-K1416).....	11
1.4.4	Cable set (BE-K1426).....	12
<b>2</b>	<b>Installing the battery modules and BMS.....</b>	<b>14</b>
2.1	Intended use.....	14
2.2	Important information about the lithium-ion battery modules.....	14
2.2.1	General note.....	14
2.2.2	Important information about the main switch of the BMS.....	15
2.3	Safety instructions.....	16
2.4	First aid measures.....	19
2.5	Installing the stackable battery system and BMS.....	20
2.5.1	Aligning and fastening the base plate.....	20
2.5.2	Prepare drill holes for wall brackets.....	22
2.5.3	Installing the battery modules and BMS.....	23
2.5.4	Minimum clear distances between the stackable battery system.....	29
2.5.5	Installing multiple stackable battery systems.....	29
2.5.6	Mount the cover panels.....	30
<b>3</b>	<b>Install battery modules and BMS.....</b>	<b>33</b>
3.1	Safety instructions.....	33
3.2	Connecting the battery modules together.....	33
3.3	Installing the BMS.....	34
3.3.1	Connect the PE cable.....	34
3.3.2	Installation on a stackable battery system.....	35
3.3.3	Retrofitting of battery modules.....	36
3.4	Switch on BMS.....	39
3.5	Display of the battery status on the BMS.....	40
3.5.1	Battery level.....	40
3.5.2	Error codes.....	40
<b>4</b>	<b>Retrofitting individual battery modules.....</b>	<b>43</b>
4.1	Measuring the voltage of the retrofitted battery modules.....	43
4.2	Battery voltages of existing battery modules.....	44
4.3	Installing new battery modules.....	44

# 1 Battery system components

## 1.1 Base plate

### Detailed view

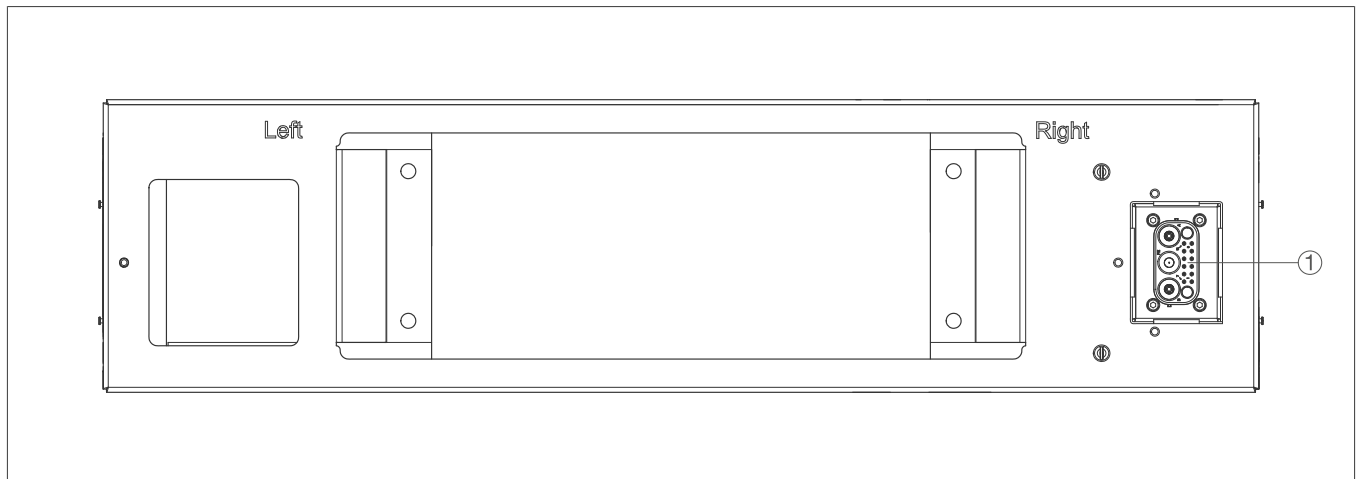

Fig. 1: Base plate detailed view

Item	Description	Function
①	Module output connection	Connectors with power and communication connections

Table 1: Base plate detailed view

**Dimensions**

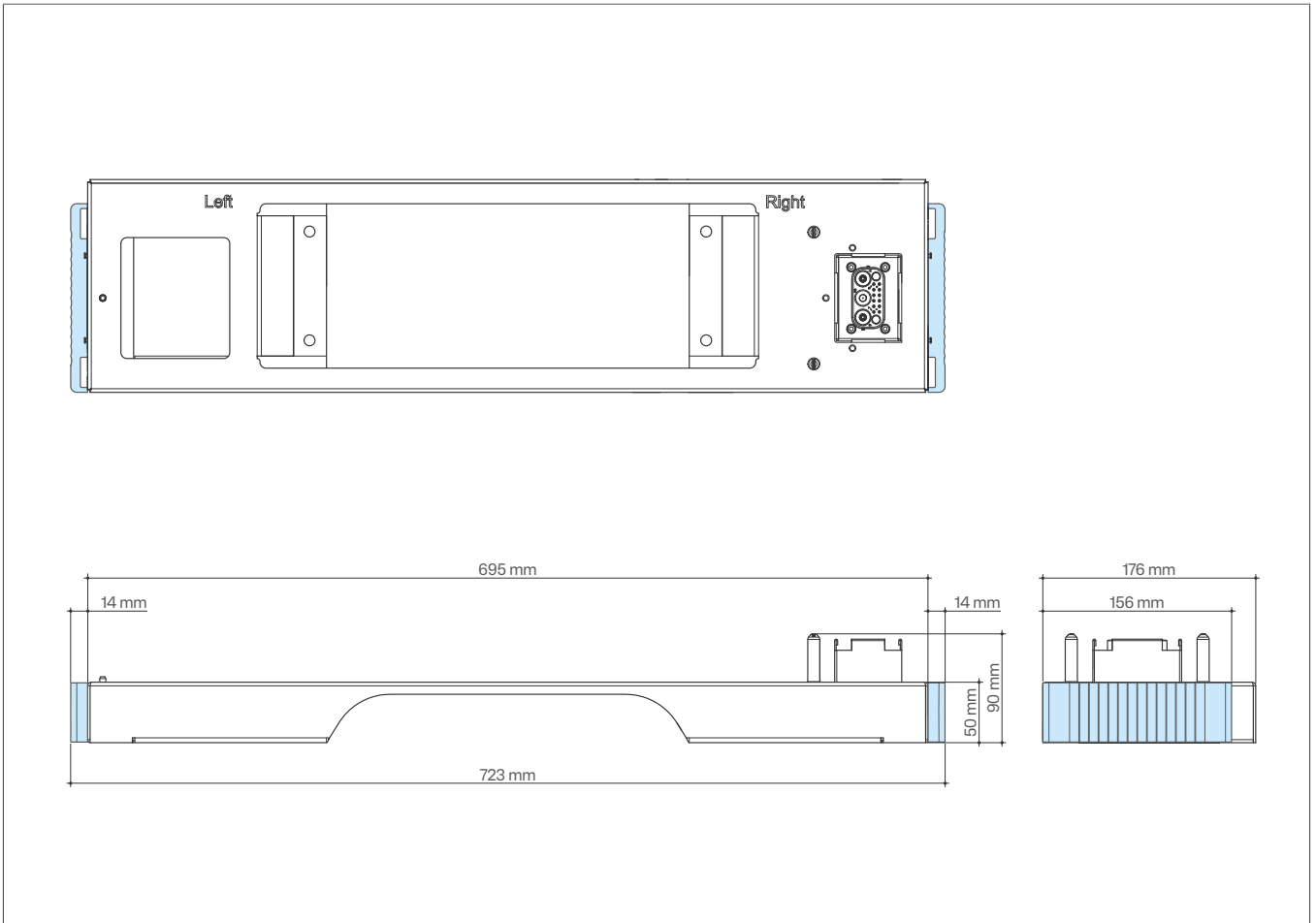

Fig. 2: Base plate dimensions

**Weight**

Weight	3 kg
--------	------

Table 2: Base plate weight

## 1.2 Battery module DCB-SAHoc

### Detailed view

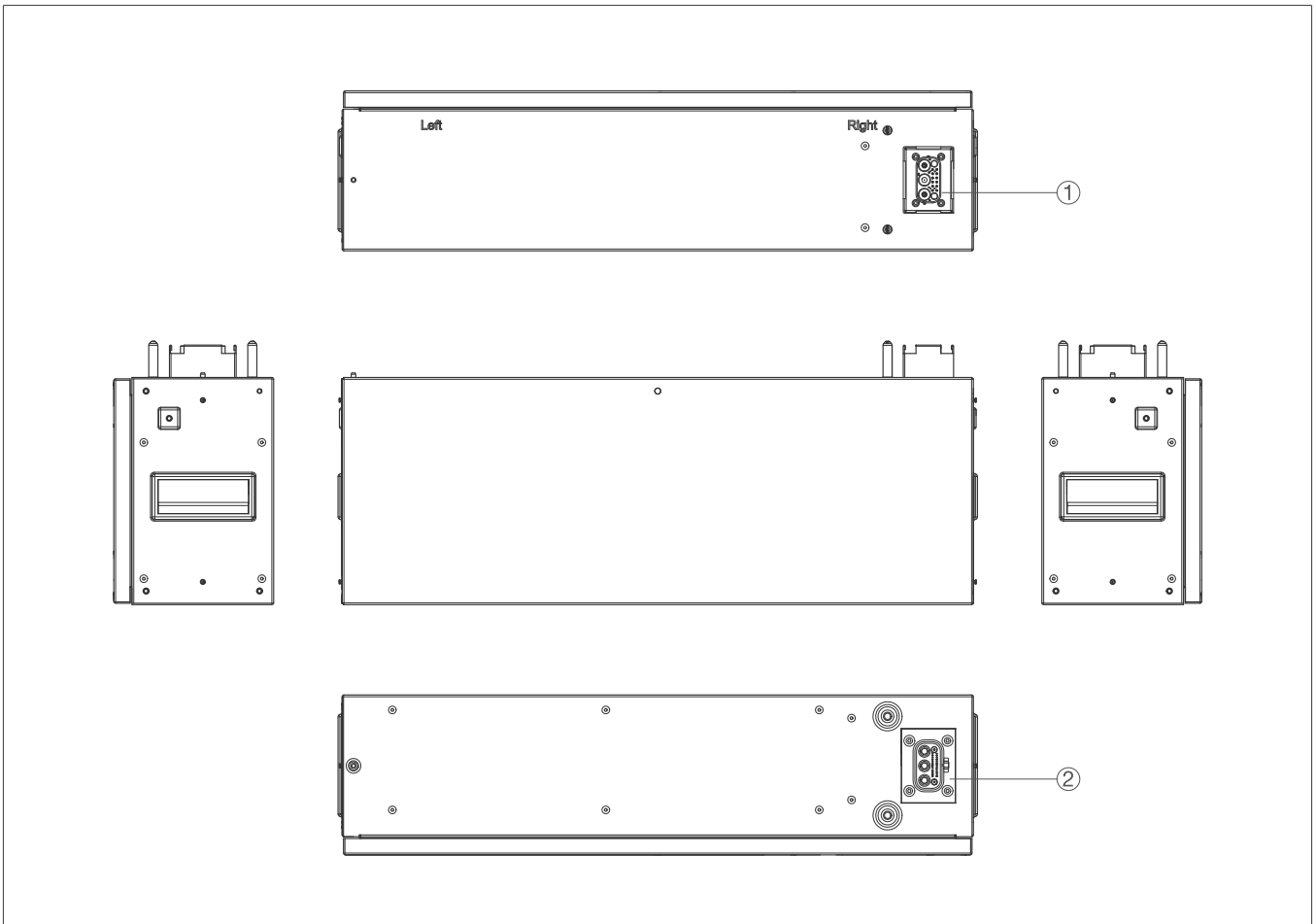

Fig. 3: Battery module detailed view

Item	Description	Function
①	Module output connection	Connectors with power and communication connections on the top
②	Module input connection	Connectors with power and communication connections on the bottom

Table 3: Battery module detailed view

**Dimensions**

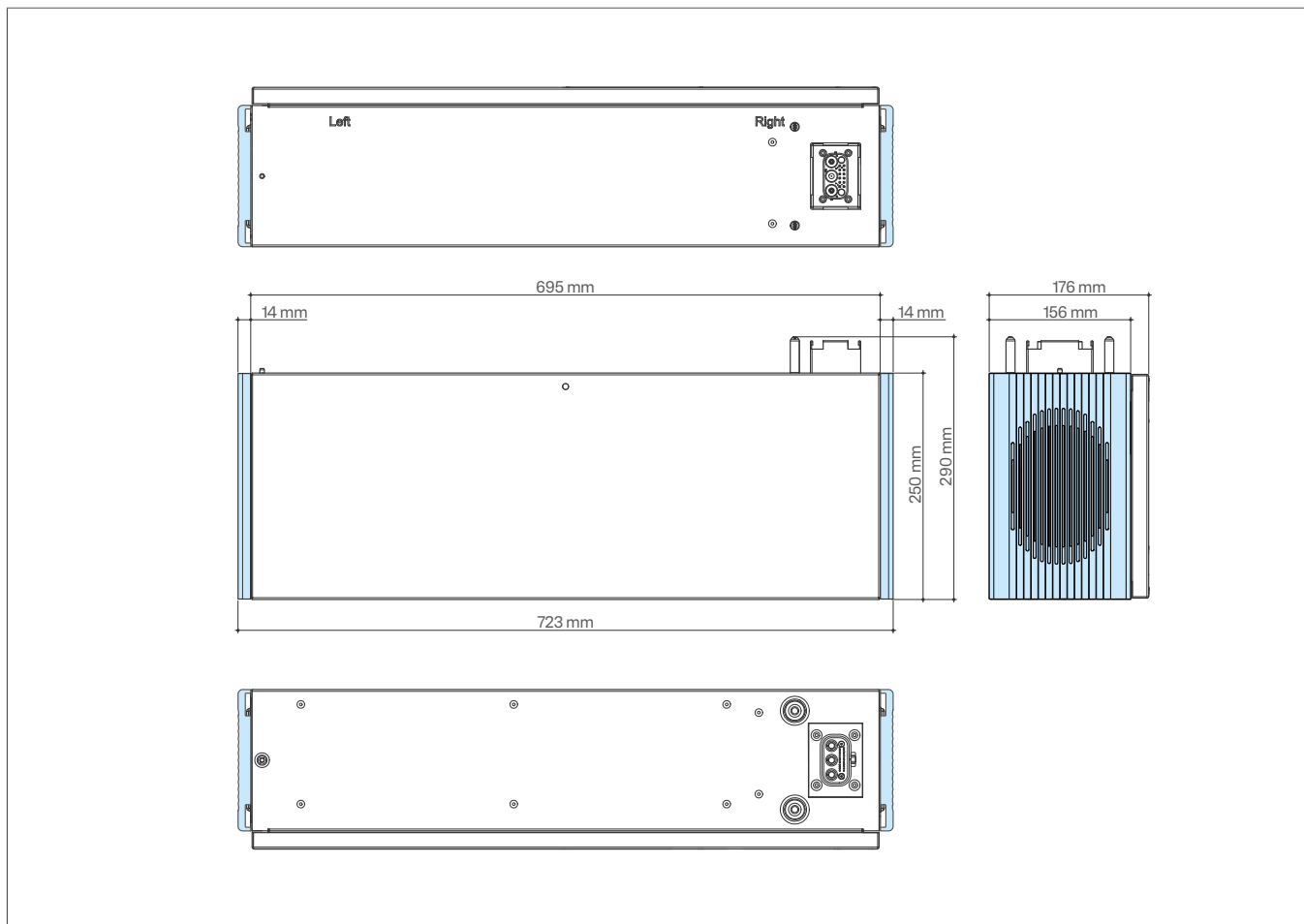

Fig. 4: Battery module dimensions

**i Note**  
In conjunction with the **flow R3**, a battery system can include up to six battery modules.

**Weight**

Weight	33 kg
--------	-------

Table 4: Battery module weight

## 1.3 Battery management system

### Detailed view

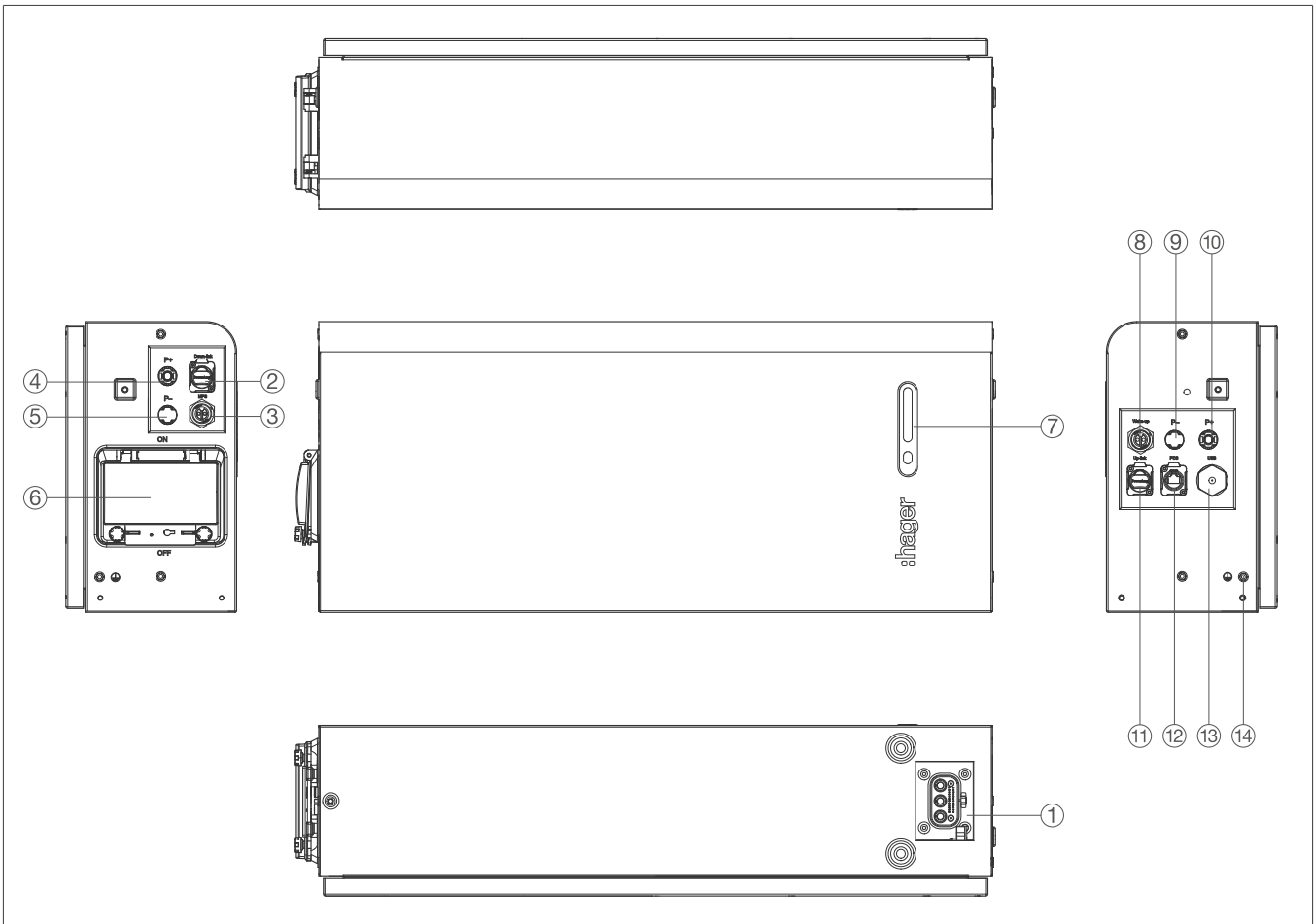

Fig. 5: Battery Management System (BMS) Detailed view (as per drawing)

Item	Description	Function
①	BMS input connection	Connectors with power and communication connections.
②	Downlink	Termination resistor connection <sup>[1]</sup>
③	MPS	Service connection
④	P+	Positive parallel connection
⑤	P-	Negative parallel connection
⑥	Breaker	DC disconnect switch
⑦	SOC R/A	Display showing the battery level, operating mode and alarm status
⑧	Activation	Connection for 12-V activation signal cable
⑨	P-	Negative terminal of the battery cable between the inverter and the BMS.
⑩	P+	Positive terminal of the battery cable between the inverter and the BMS.

Table 5: Battery Management System (BMS) Detailed view

Item	Description	Function
⑪	Uplink	Termination resistor connection <sup>[1]</sup>
⑫	PCS	RJ45 communication connection between the BMS and inverter.
⑬	USB	USB port
⑭	-	Equipotential bonding

Table 5: Battery Management System (BMS) Detailed view

<sup>[1]</sup> The termination resistors are usually plugged into the BMS. Otherwise, they are in the packaging of the BMS.

**Dimensions**

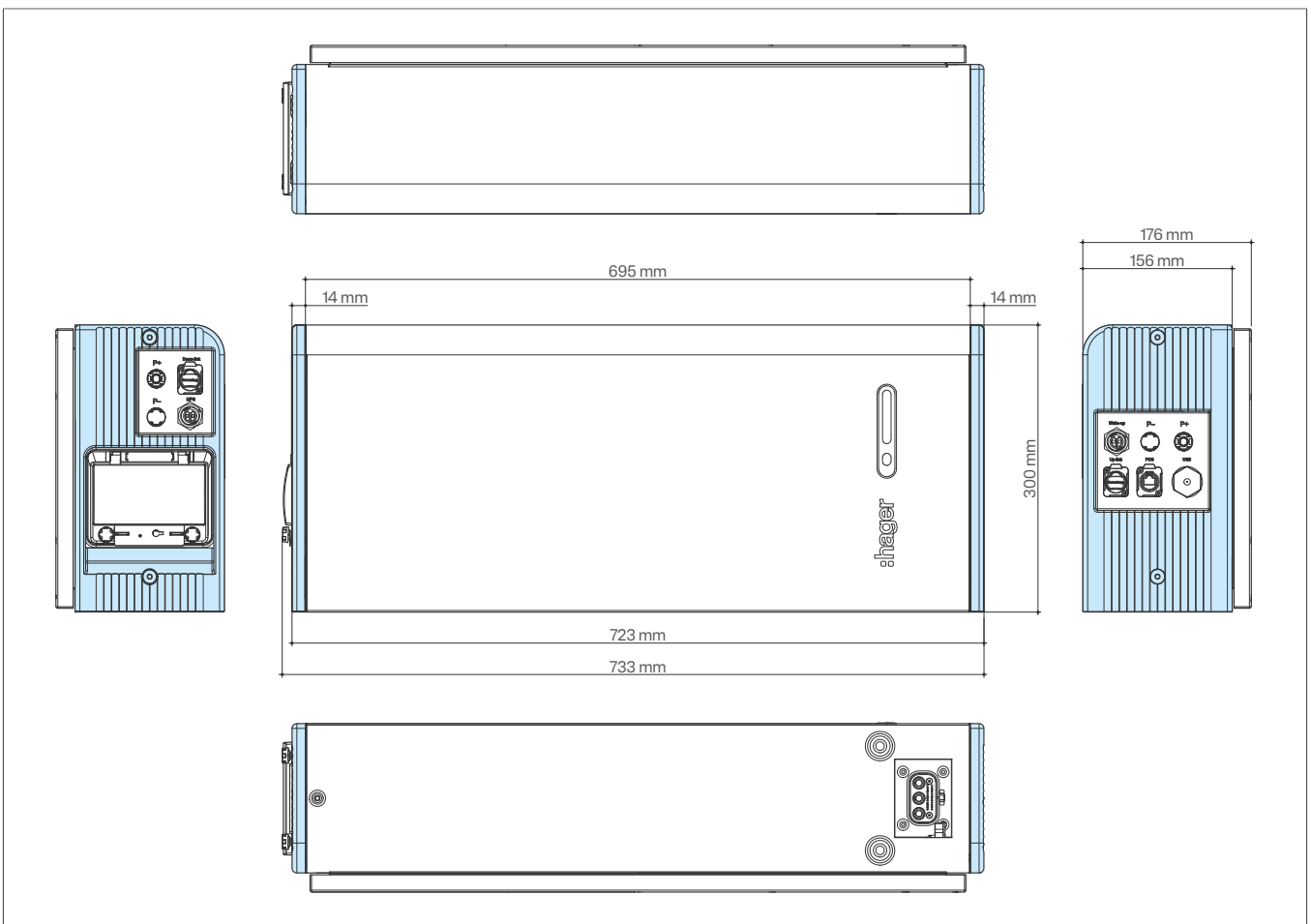

Fig. 6: Battery Management System (BMS) Dimensions

**Weight**

Weight	14 kg
--------	-------

Table 6: Battery Management System (BMS) Weight

## 1.4 Scope of delivery

### 1.4.1 Accessory pack for battery type DCB-SAHOc



**Note**

The scope of delivery shown here may differ from the scope of delivery indicated on the delivery note or may be replaced by alternatives.

Item number	Designation	Number
BE-B1417	flow R3 accessories box	1
BE-K1414	Cable_COM_12V_SYS_HVB, Stack_2,5M	
BE-K1416	Cable_Power_Sys_HVB Stack_2.5M	
<b>Optional:</b>		
BE-K1415	Cable_COM_12V_SYS_HVB Stack_10M	1
BE-K1421	Cable_COM_12V_SYS_HVB Stack_30M	
BE-K1417	Cable_Power_Sys_HVB Stack_10M	
BE-K1422	Cable_Power_Sys_HVB Stack_30M	
<b>Optional:</b>		
BE-K1426	HVB-S_HVB-S_2M S20 cable set for installing multiple stackable battery systems	Number of stackable battery systems minus 1
BE-K1423	Cable_LINK_HVB-S_2M	
BE-K1424	Cable_HVB-S_HVB-S_2M	
BE-K1425	Line_Power BAT MINUS_4M	
CAN gateway OPT3150080000	Prerequisite for using the external power meters from HagerEnergy GmbH	1

Table 7: Accessory pack for battery type

The following information label is located in the additional packaging box (according to VDE-AR-E 2510-2 Application rule:2021-02).

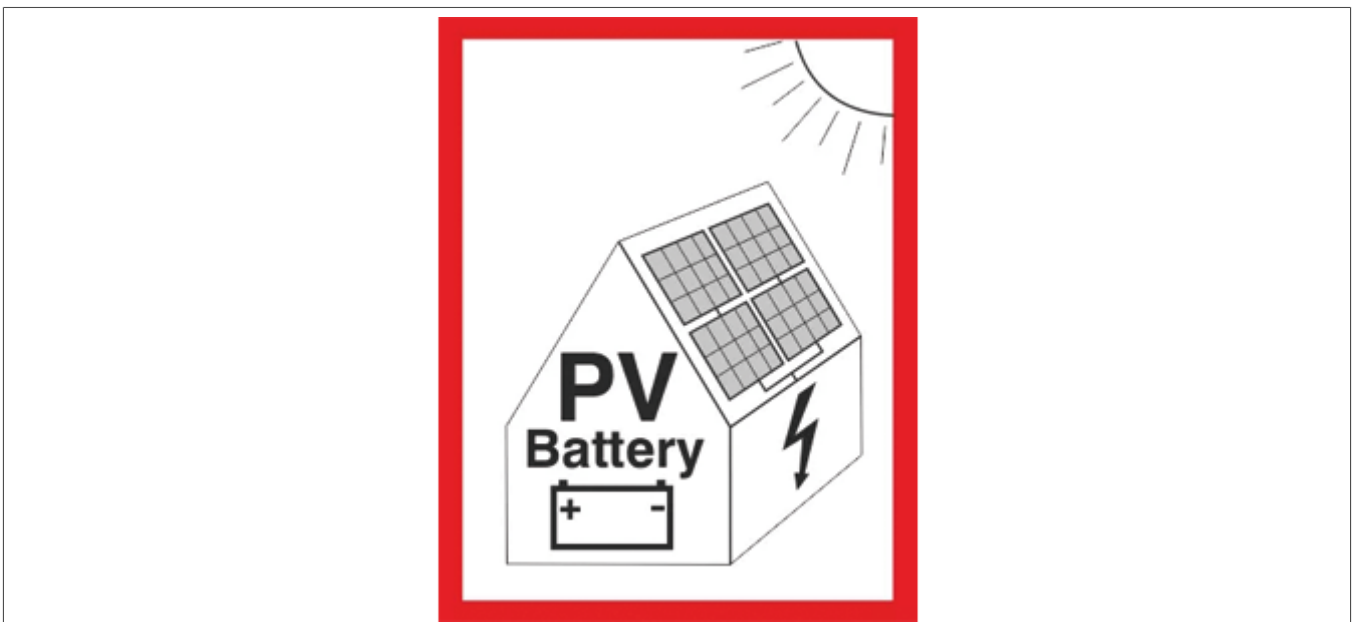

Fig. 7: Information plate for the PV system with energy storage system

In accordance with the standard, this information label indicates the electrical hazards when a storage system is installed. This information label must be permanently affixed by the installer/operator in a clear location near the distribution board.

### 1.4.2 Communication cable (BE-K1414)

Number: 1

The communication cable between the BMS and the inverter system provides a 12-V supply voltage, which is used to activate the battery modules.



Fig. 8: BE-K1414 communication cable

### 1.4.3 Battery cable (BE-K1416)

Number: 1

Battery cable between the inverter and BMS.



Fig. 9: BE-K1416 battery cable

### 1.4.4 Cable set (BE-K1426)



**Note**

The following cables are only used when installing more than one stackable battery system.

#### **Communication cable (BE-K1423)**

Number: Number of stackable battery systems minus 1

Communication cable between the BMS of the stackable battery systems.



Fig. 10: BE-K1423 communication cable

#### **Battery cable (BE-K1424)**

Number: Number of stackable battery systems minus 1

Battery cable between the first and second BMS.



Fig. 11: BE-K1424 battery cable

**Battery cable (BE-K1425)**

Number: 1

Extension for the negative terminal of the BE-K1416 battery cable.



Fig. 12: BE-K1425 battery cable

## 2 Installing the battery modules and BMS

### 2.1 Intended use

HagerEnergy GmbH battery modules are designed for use exclusively in suitable HagerEnergy GmbH storage systems.

HagerEnergy GmbH does not assume any liability for damages and accidents caused by improper or incorrect use of the battery modules.

- Use the battery module only in accordance with the manufacturer's instructions from Hager.
- Handle the battery module with care during transport and comply with the statutory regulations for battery transport!



For more information on the safe transport of battery modules, please contact us at **+ 49 6842 945 98 00**.

- Only use the battery module if it is functional and has no mechanical damage.
- Do not open, disassemble, repair, tamper with or modify the battery module.
- The battery module must not be serviced by the user.
- Do not apply strong forces or mechanical stresses.
- Do not insert foreign objects into the battery module.
- Clean only the external part of the battery module with a dry or slightly moistened cloth, without cleaning products.
- Only for use in indoor areas free of dripping and splashing water

### 2.2 Important information about the lithium-ion battery modules

#### 2.2.1 General note

Take care when handling battery modules!

Battery modules can present potential hazard. Extremely high short circuit currents can be created if handled incorrectly!



#### Note

Battery modules are never completely discharged!

The battery cells of the lithium-ion batteries are installed in a battery module. External ventilation is not required for the use of the battery modules. Their use is harmless in accordance with the manufacturer's instructions.

The battery modules are lithium-ion batteries.

The battery modules have an external battery management system (BMS) that monitors and controls the voltage, the charging and discharging currents, and the cell temperature.

The BMS protects the battery modules against overcharging, deep discharge, overcurrents and temperatures outside the permissible operating range.

In the following, the batteries are referred to as **DCB-SAHoc battery modules**.

**Note**

Make sure that the location where the batteries are installed is within the permissible operating temperature range of between -20°C and +30°C throughout the year.

Using the device outside this temperature range may lead to malfunction and will void the warranty.

## 2.2.2 Important information about the main switch of the BMS

**Use the main switch of the BMS**

Ensure that the main switch of the BMS is set to the **OFF** position:

- Before installing the system
- If the system is switched off for a longer period of time, e.g. prior to commissioning. This prevents deep discharge of the battery modules.
- When retrofitting previously installed systems
- When replacing battery modules
- After manually switching off the system
- After decommissioning the system

**Main switch of the BMS in normal operation**

The BMS main switch does not trip during normal operation!

The BMS main switch only trips in the event of a fault, for example if an overcurrent is detected.

**What should I do if the main switch of the BMS still trips?**

If the BMS main switch trips during normal operation, a detailed analysis must be performed by Hager. An error may be present.

A short circuit may be present if the installation is incorrectly installed. In such a case, the fault must be remedied by Hager Service.

**Manually switching off the system**

To fully shut down the system and prevent the battery modules from remaining in standby mode, switch off the BMS main switch manually. Otherwise, the battery modules could be discharged.

**Attention**

Deep discharge after battery installation.

A long delay between the battery module installation and the Energy management system commissioning can cause module deep discharge.

- It is essential to set the main switch of the BMS to the **OFF** position after installation.

## 2.3 Safety instructions



Electrical devices may only be installed and assembled by a qualified electrician in accordance with the relevant installation standards, guidelines, regulations, directives, and safety and accident prevention regulations of the country of installation.

National regulations and safety requirements must be observed; see also IEC 60364-7-712:2017 (DIN VDE 0100-712:2016-10).



### Danger

Electric shock when touching live parts!

An electric shock can lead to death!

- Before working on the device, disconnect the cables and secure them against reconnection. Verify that the device is voltage free, earth and short circuit it, and cover any nearby live parts.
- Disable or switch off emergency power mode.
- Before opening the device, turn the DC disconnect switch and the battery management system (BMS) main switch to the **OFF** position. Be sure to remove the DC plugs.
- Do not switch off the DC voltage by disconnecting the DC plugs only. Otherwise, there is a risk of arcing.
- All applicable safety regulations, the technical connection requirements (TAB) of the responsible energy supply company and the VDE regulations must be observed when installing and operating the device.
- Calculate and provide the necessary protection for cables and personnel.



### Danger

Danger to life due to electrical voltage!

Due to increased risks of hazards associated with handling batteries, personal protective measures are required.

- Wear electrically insulating protective gloves for working on live parts in accordance with DIN EN 60903.
- Wear safety glasses to prevent parts getting into your eyes in the event of an arc fault caused by a short circuit.

**Danger**

Danger to life due to electrical voltage!

Energised parts can cause serious injuries.

- Read and observe all the printed information provided as well as the technical documentation available online before working on the battery modules.
- Do not install the battery storage system in areas where flooding may occur!
- Do not install the battery storage system in a location with high humidity.
- Reduce dust contamination to a minimum.
- Set the main switch in the BMS to the **OFF** position.
- Wear safety glasses and protective gloves when working on the battery modules.
- Remove conductive jewellery such as watches, bracelets and rings.

**Warning**

Explosion when used improperly.

Improper handling of battery modules can result in explosion, fire or corrosive leakage.

- Do not heat the battery module or expose it to open fire.
- Do not short-circuit the battery module or reverse the polarity.
- Do not subject the battery module to impacts, external damage, or disassembly.

**Danger**

Risk of fire from high temperatures.

If the battery module is exposed to high temperatures, battery fluid may leak and ignite.

- Do not expose the battery module to pressure or temperatures above 55°C.
- Do not place the battery module near a heat source such as a fireplace.
- Do not expose the battery module to direct sunlight.
- Prevent any contact between the battery terminals and electrically conductive materials, such as wires.
- Replace the damaged battery module immediately and dispose of it in an environmentally friendly manner. Wear protective gloves if necessary.
- Replace the battery module only with the same or equivalent type from Hager.

**Danger**

Electric shock when live parts are touched!

An electric shock can lead to death!

- Do not open the battery module.
- Do not touch the battery module with damp hands or expose it to moisture or liquids.
- Keep new and used battery modules away from children and animals.



### Danger

Danger due to battery modules being delivered partially charged.  
Energised parts can cause serious injuries.

- Take special care when making electrical connections.



### Danger

Injuries caused by contact with leaking electrolytes.  
Contact with electrolytes can cause injuries to unprotected eyes and skin.

- To prevent such injuries, do not touch leaking battery modules without protective gloves and wear safety glasses.



### Caution

Live parts on batteries without a separate isolator!  
Serious personal injury due to the presence of voltage throughout the system when the lines between the BMS and the unit are connected and the main switch on the BMS is in the **ON** position.

- Since this type of battery does not have a separate on/off switch, do not switch on the device until it has been carefully checked that the battery modules are installed correctly.



### Caution

Risk of injury due to sharp edges!  
Sharp edges may cause hand injuries.

- Wear gloves when installing and installing the battery modules.



### Caution

Crushing due to high weight!  
Careless storage of the appliance can result in foot injuries.

- Wear safety shoes.



### Attention

Damage to the battery modules during transport!  
The battery module can only be transported safely and without damage in its original protective packaging.

- The battery modules must be transported to the installation location in their original packaging and then removed from the packaging.
- Keep the original boxes of the battery modules. If the battery module is replaced, it can be transported safely in accordance with UN38.3 hazardous goods class 9. This also applies to the subsequent disposal of the battery modules.



**Attention**

Product damage due to mechanical stress!

Battery modules may be damaged if used improperly.

- Do not allow battery modules to come into contact with liquids.
- Do not expose battery modules to pressure loads.
- Do not place objects on battery modules.



**Attention**

Damage to the product due to improper handling!

If the battery modules are used incorrectly, damage to the product can be caused.

- Always handle battery modules carefully. This is because battery modules are never completely discharged. Even if they are obviously discharged, very high short-circuit currents can be caused if they are handled incorrectly.
- Since the battery cells are installed in a battery housing, external ventilation is not required. Use battery modules in accordance with the manufacturer's specifications.

**2.4 First aid measures**



**Danger**

Burn injuries caused by electrolytes.

Leaking battery fluid can easily ignite or produce toxic fumes and cause serious injury.

- In the event of burns, perform first aid and then consult a doctor.
- If you detect smoke or fumes, leave the room immediately to prevent inhaling harmful substances.
- If smoke or gases have been inhaled in large quantities or if there is a noticeable irritation to the respiratory tract, seek medical attention.
- Provide sufficient cooling.



**Danger**

Injuries caused by contact with leaking electrolytes.

Contact with electrolytes can cause injuries to unprotected eyes and skin.

- Rinse eyes thoroughly with water. Then seek medical attention.
- Rinse affected skin sections with water for at least 15 minutes.
- To prevent such injury, do not handle leaking battery modules without protective gloves.

## 2.5 Installing the stackable battery system and BMS

### 2.5.1 Aligning and fastening the base plate

- 1 Position the base plate in an appropriate spot on the surface. Suitable surfaces are flat surfaces that can support the weight of the battery modules. Note the **Left** and **Right** markings.
- 2 Place the base plate 15 to 25 mm away from the wall.

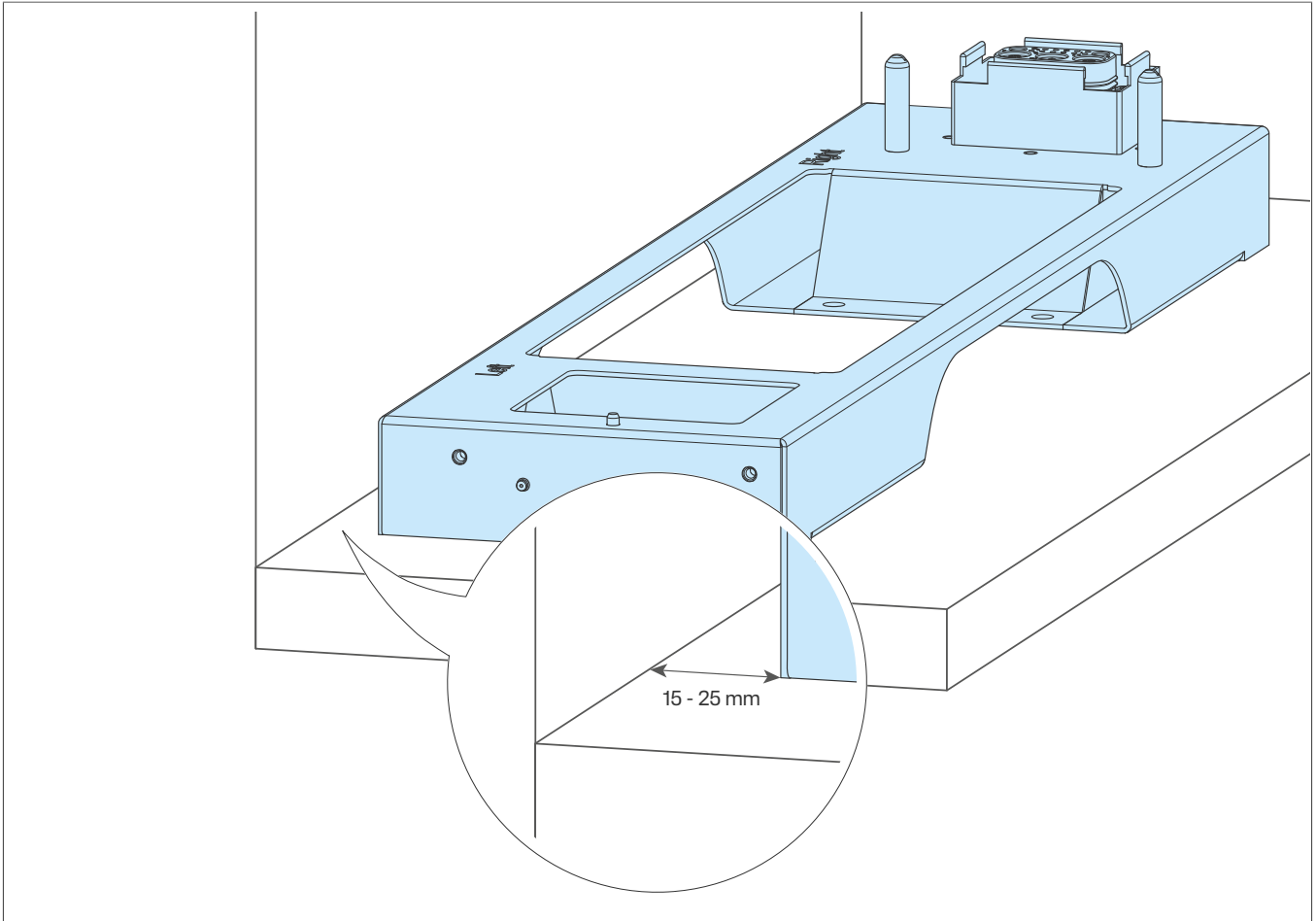

Fig. 13: Aligning the base plate



#### Note

Heavy-duty anchors only need to be used in areas prone to earthquakes.

- 3 Drill four holes ( $\varnothing$  8 mm) through the base plate into the surface.

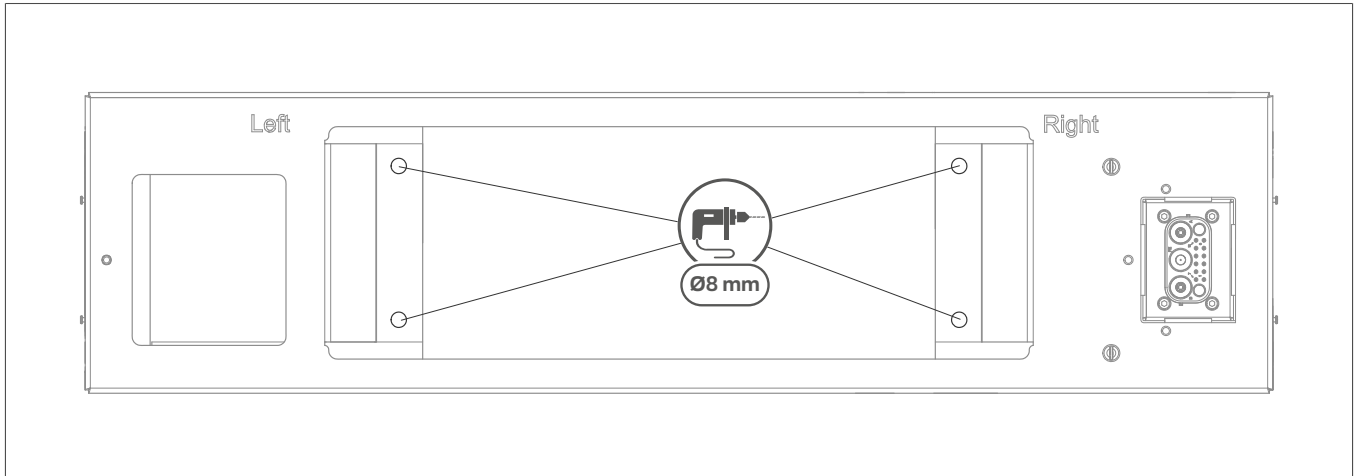

Fig. 14: Drilling the holes

- 4 If necessary, insert four M6 × 60 heavy-duty anchors (1) into the holes.

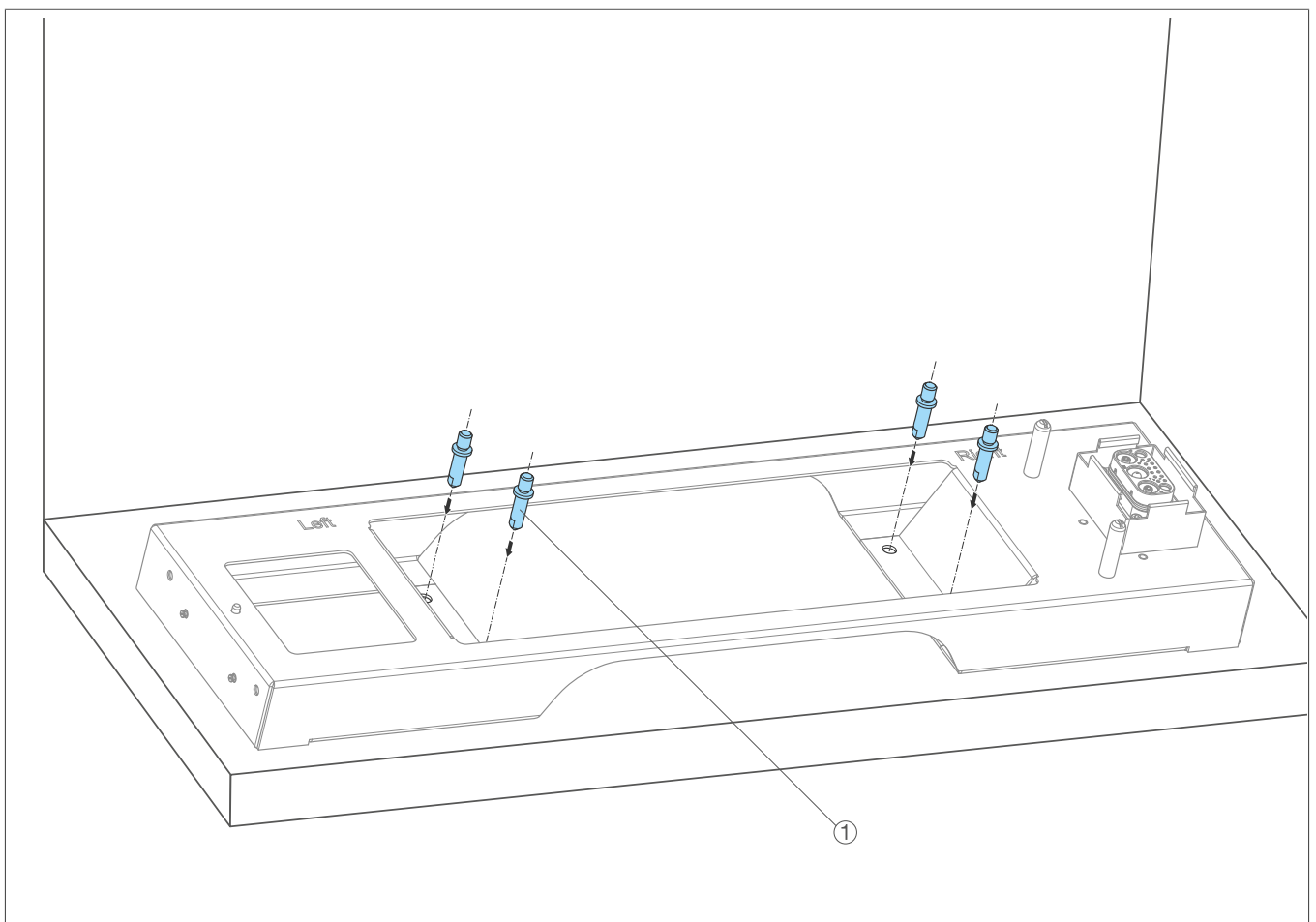

Fig. 15: Insert heavy-duty anchors

- 5 Use a spirit level to check that the base plate is level. If the ground is uneven, take appropriate measures to correct the alignment.

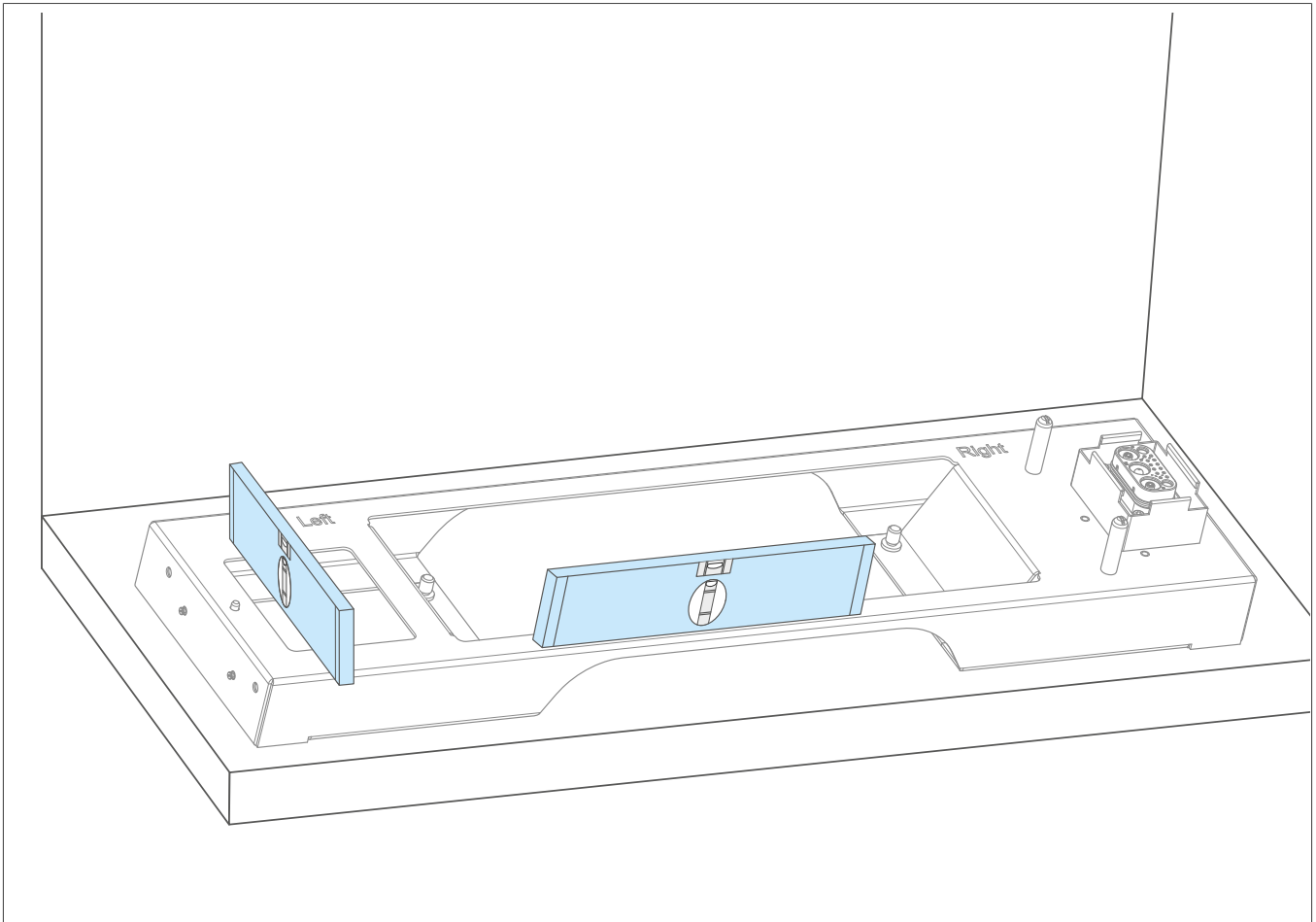

Fig. 16: Aligning and fastening the base plate

- 6 Tighten the heavy-duty anchors to 5 Nm.  
The base plate is installed.

## 2.5.2 Prepare drill holes for wall brackets

The battery modules must also be mounted to a suitable wall with wall brackets.



### Note

Walls made of hard building materials such as concrete or solid masonry are suitable. For this purpose, the appropriate mounting material is supplied. For other walls, such as light-weight walls made of plasterboard, suitable mounting materials must be used.

Mount each battery module on the wall using a wall bracket for both the left and right sides. The BMS must be mounted with two wall brackets.

- 1 Align the supplied drilling template in front of the base plate.



### Note

The drilling template is properly aligned when the line (green arrow in [Fig. 17](#)) at the bottom of the drill template is flush with the top edge of the base plate.

Alignment with the bottom edge of the drill template (red arrow) is incorrect.

- 2 Remove the double-sided adhesive tape from the supplied drill template and stick it to the wall. Alternatively, the dimensions can also be transferred from Fig. 17 to the wall.
- 3 Drill the mounting holes for the battery modules and the BMS according to the system configuration.

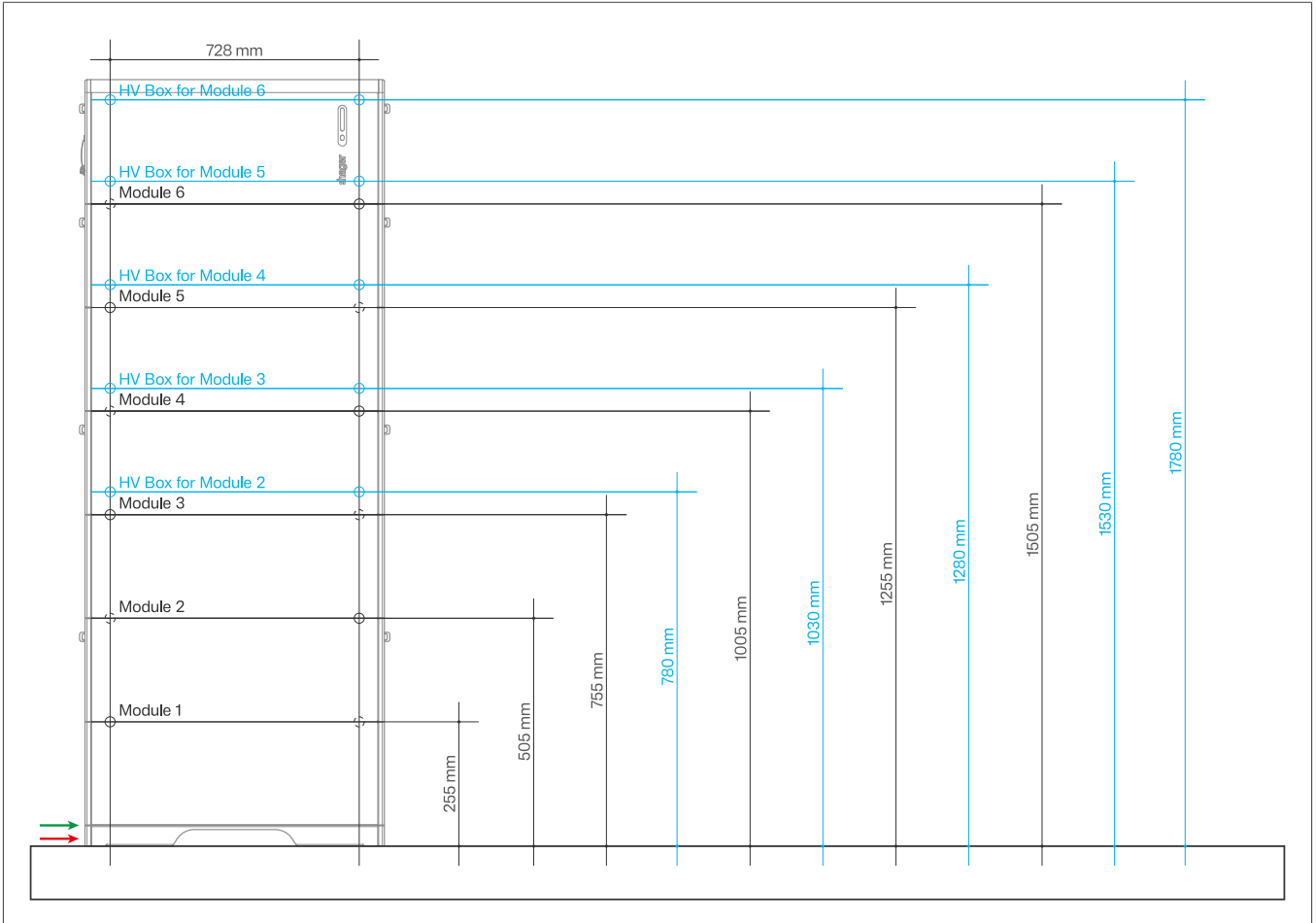

Fig. 17: Dimension drawing of the supplied drilling template (similar to figure)

**Note**  
The number of battery modules depends on the battery capacity ordered.

### 2.5.3 Installing the battery modules and BMS

**Caution**  
Risk of injury due to overturning battery modules!  
The weight of overturning battery modules can cause severe crushing.

- Wear safety shoes.
- After stacking a battery module on another, immediately attach it to the wall using a wall bracket.

The holes for the wall brackets are drilled.

- 1 Note the **Left** and **Right** markings on the base plate and on the battery modules.
- 2 Make sure that there are no objects (shims, gaskets etc.) near the positioning pins (3).

- ③ Make sure that the two gaskets (4) are installed on the underside.
- ④ Carefully place the first battery module (1) on the base plate (2). The positioning pins make sure that the battery module is aligned correctly.

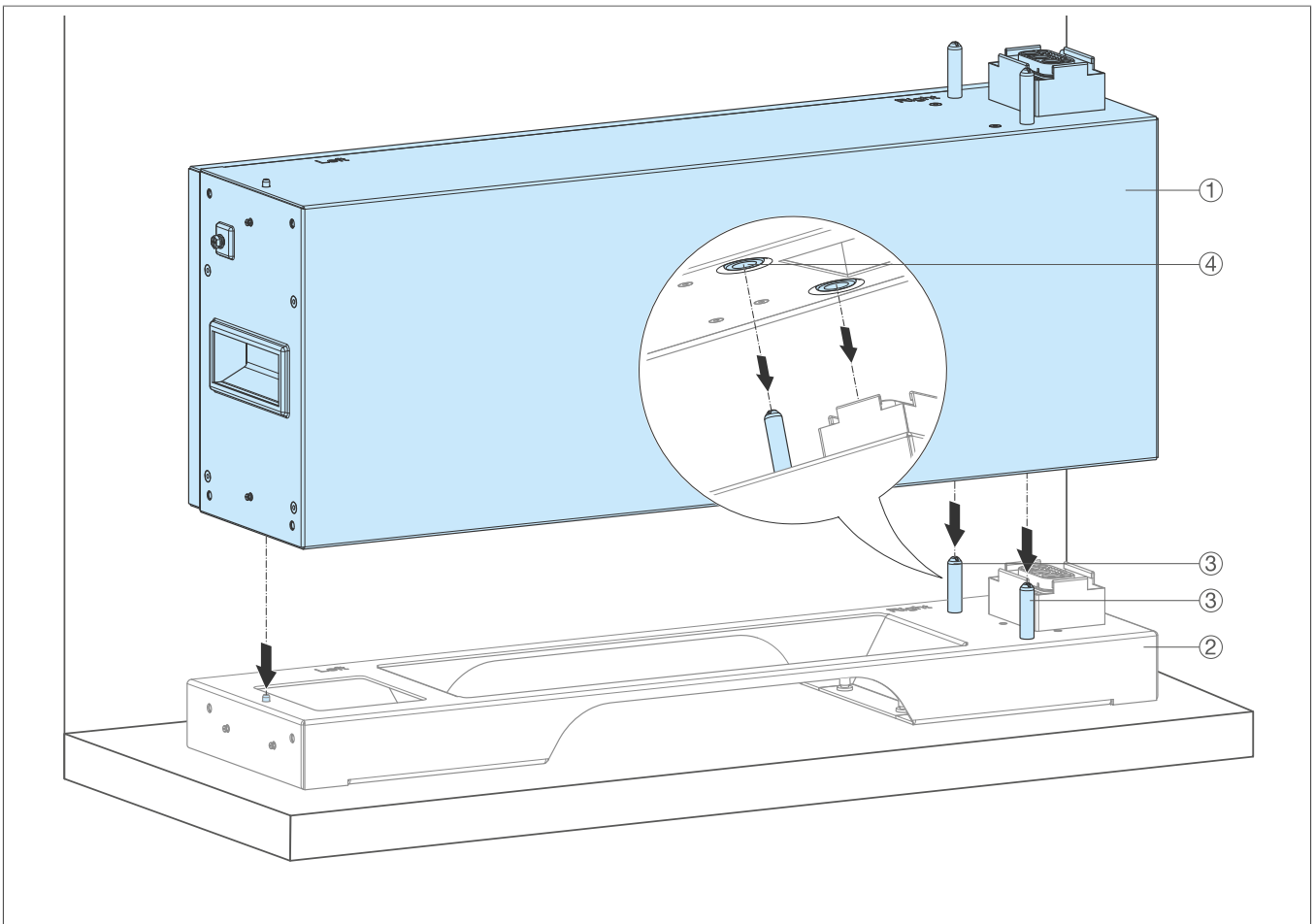

Fig. 18: Install the first battery module

- ⑤ Insert a heavy-duty anchor (5) through the wall bracket (6) into the prepared hole on the left-hand side.
- ⑥ Tighten the heavy-duty anchor to a torque of 5 Nm.
- ⑦ Screw the wall bracket onto the left side of battery module 1 using an M5 × 12 combination screw (7).
- ⑧ Tighten the combination screws to a torque of 3 Nm.

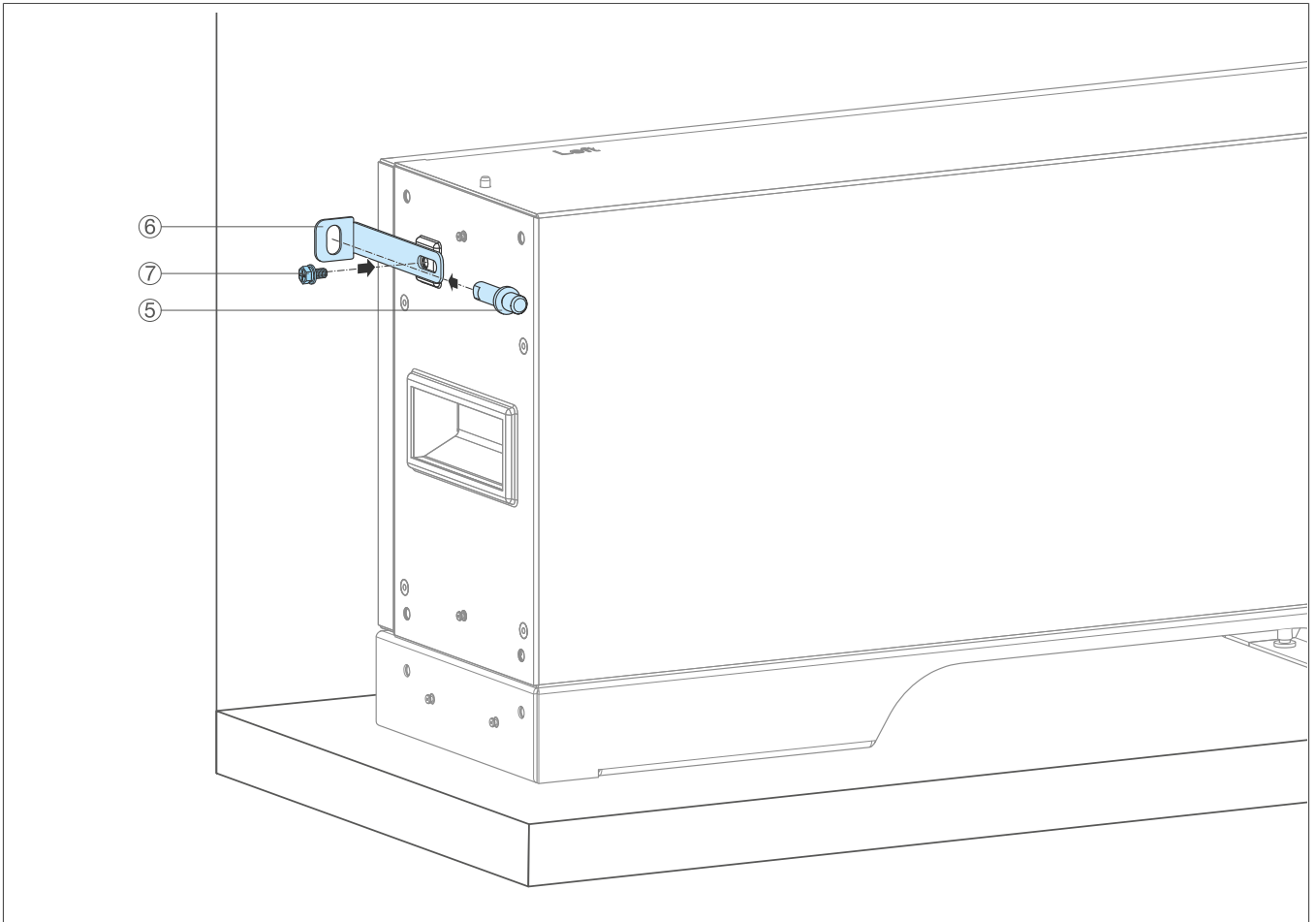

Fig. 19: Installing the first wall bracket

- 9 Carefully place battery module 2 (8) on battery module 1 (1).
- 10 Fasten the connecting rails (10) to the left and right sides of the base plate (9) and battery module 2 using M5 × 12 combination screws (11).
- 11 Tighten the combination screws to a torque of 3 Nm.

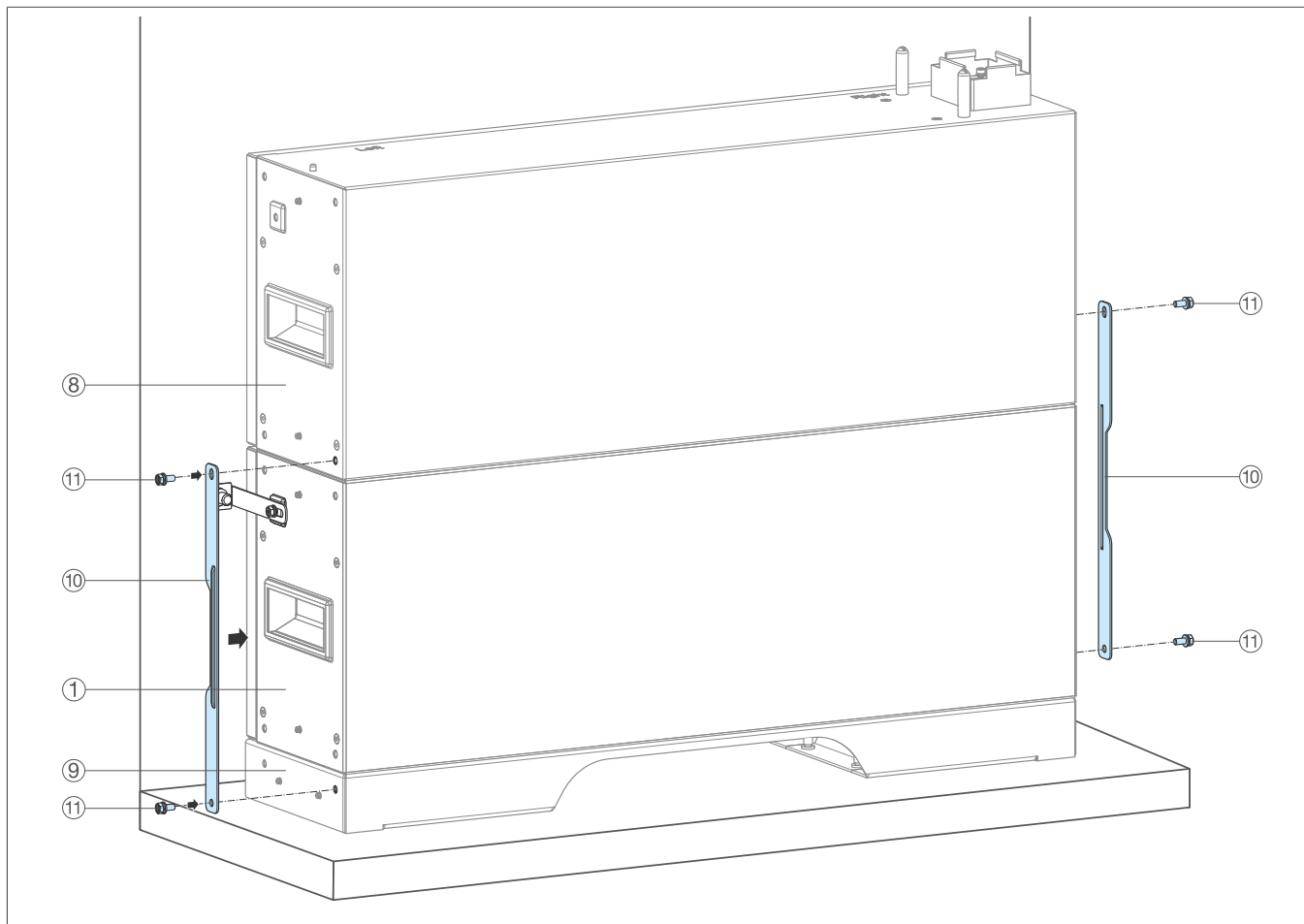

Fig. 20: Installing the first connecting rails

- 12 Insert the next heavy-duty anchor for the second battery module through the wall bracket (12) into the prepared hole on the right side.
- 13 Tighten the heavy-duty anchor to a torque of 5 Nm.
- 14 Screw the wall bracket onto the right-hand side of battery module 2 using a combination screw M 5 x 12.
- 15 Tighten the combination screws to a torque of 3 Nm.

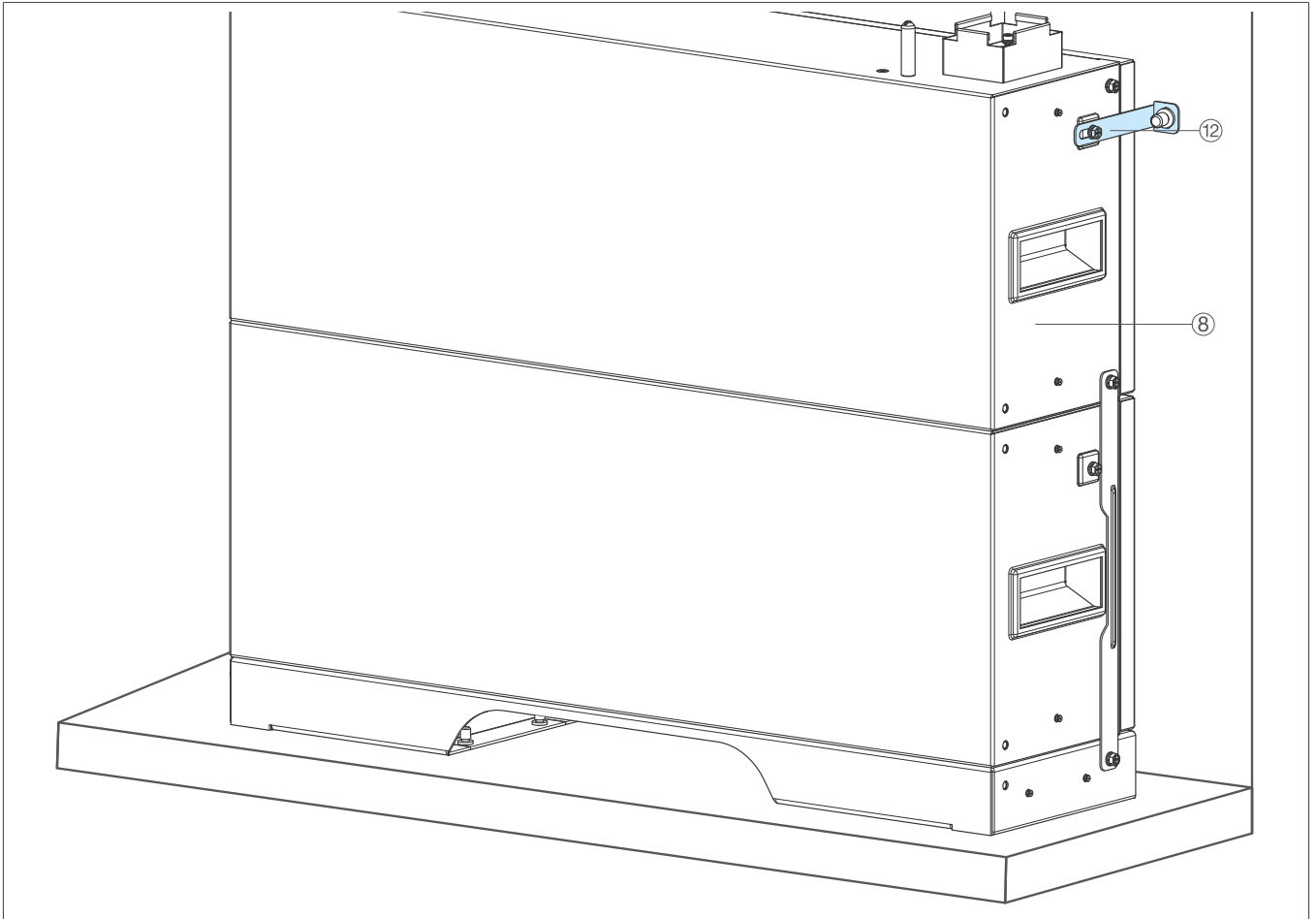

Fig. 21: Install the second wall bracket

- 16 Install the next battery module and continue as described in step 4.
- 17 Place the BMS on the last battery module and insert two heavy-duty anchors through the wall brackets (13) into the prepared holes on the right and left sides.



Note

The number of battery modules depends on the battery capacity ordered.

- 18 If necessary tighten the heavy-duty anchors to a torque of 5 Nm.
  - 19 Screw the wall brackets onto the right and left sides of the BMS using a combination screw M 5 x 12.
  - 20 Fasten the connecting rails (14) to the left and right sides of the penultimate battery module and the BMS using M5 × 12 combination screws.
  - 21 Tighten the combination screws to a torque of 3 Nm.
- The battery modules and the BMS are mounted.



Fig. 22: Overview of all fasteners (see image)

### 2.5.4 Minimum clear distances between the stackable battery system

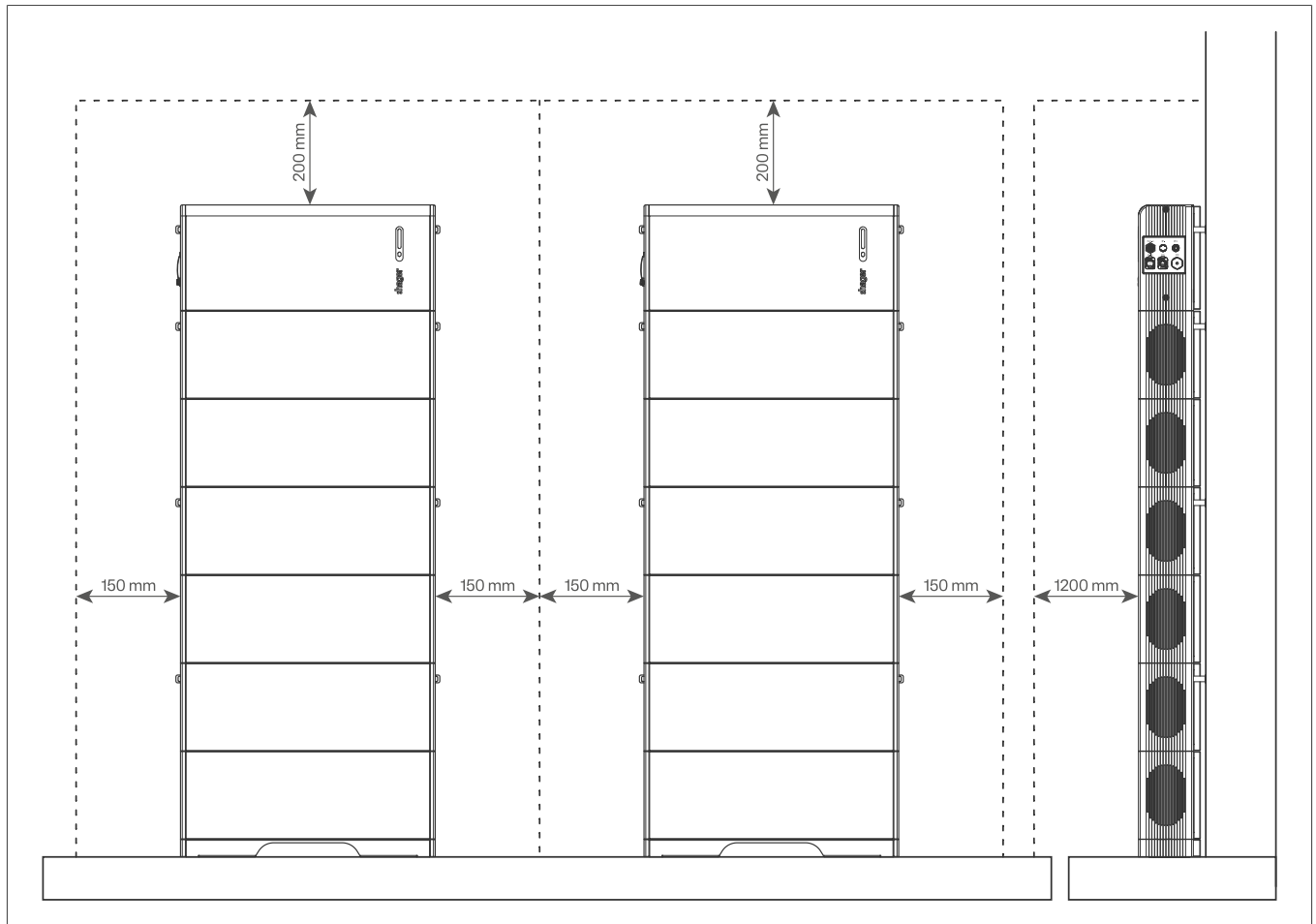

Fig. 23: Minimum clearances for the stackable battery system (see image)

### 2.5.5 Installing multiple stackable battery systems

Multiple stackable battery systems must be installed side-by-side on a wall. Individual stackable battery systems must be installed as described in [Installing the battery modules and BMS](#).



**Note**

A maximum of 2 stackable battery systems may be installed on an inverter (Risk of injury due to overturning battery modules!).

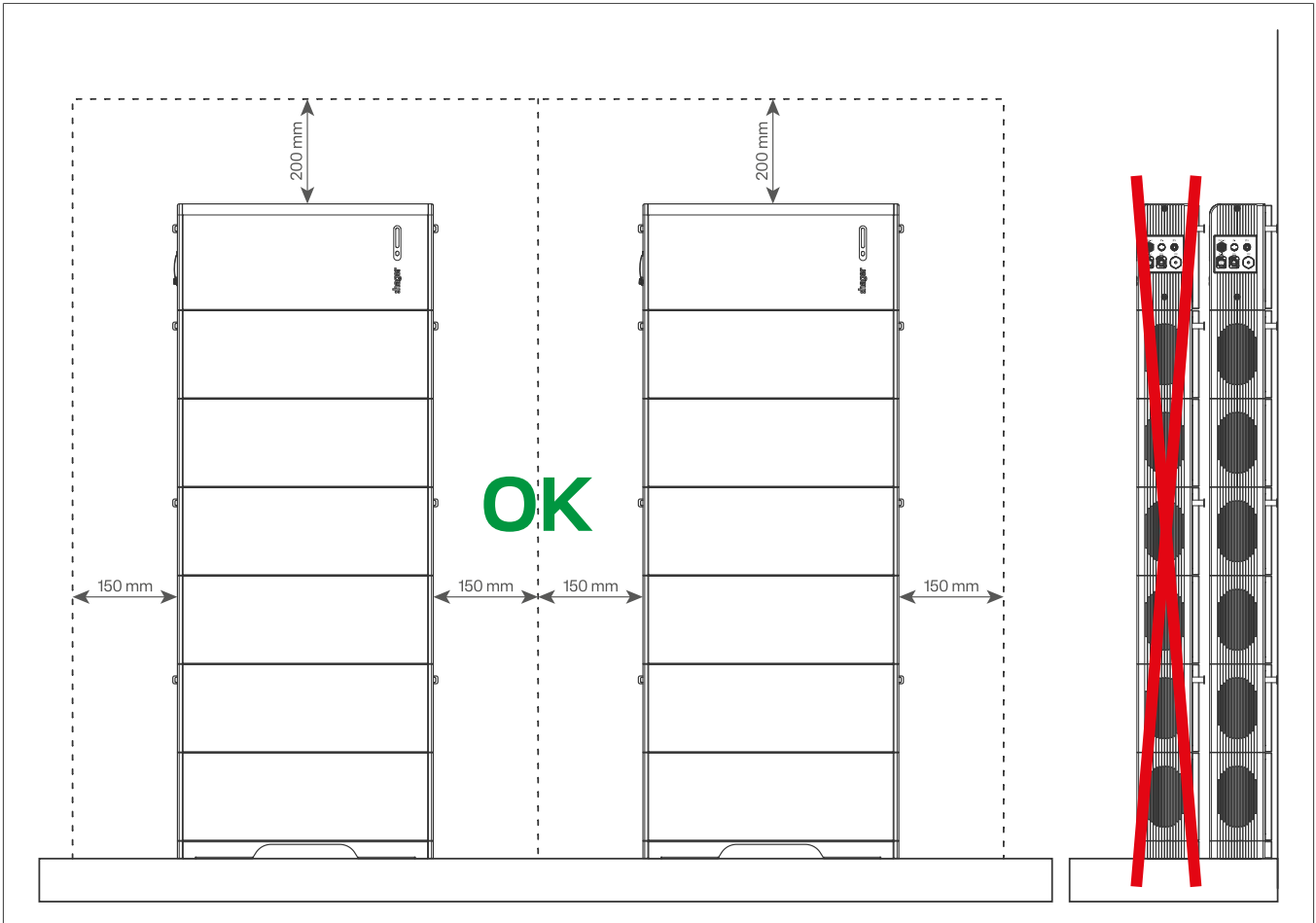

Fig. 24: Permitted and not permitted mounting variant (as per drawing)

## 2.5.6 Mount the cover panels

- ☑ The battery modules and the BMS are correctly mounted and mounted to the wall.



### Note

The covers are different on the left and right sides. The cut-out on the narrow side must face the wall.

The mounting of the cover panels is identical for both sides.

- 1 Insert the base plate cover panel (1) with the recesses over the bolts (29) and press down.

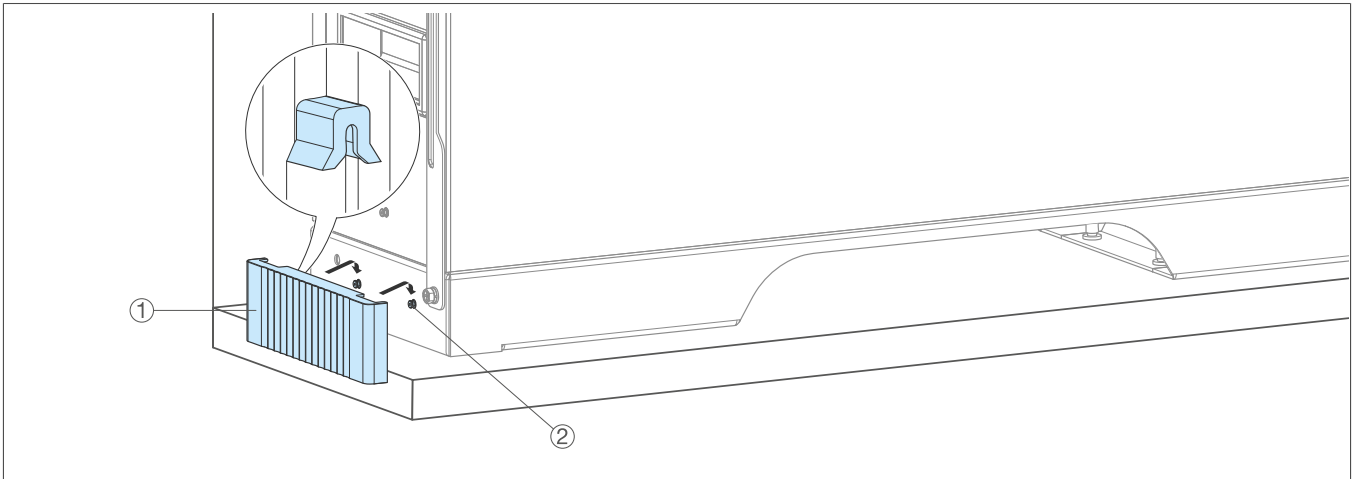

Fig. 25: Attaching the cover panel to the base plate

- 2 Insert the cover panel (3) for the first battery module with the recesses over the bolts (4) and press down.
- 3 Repeat the procedure for all other battery modules

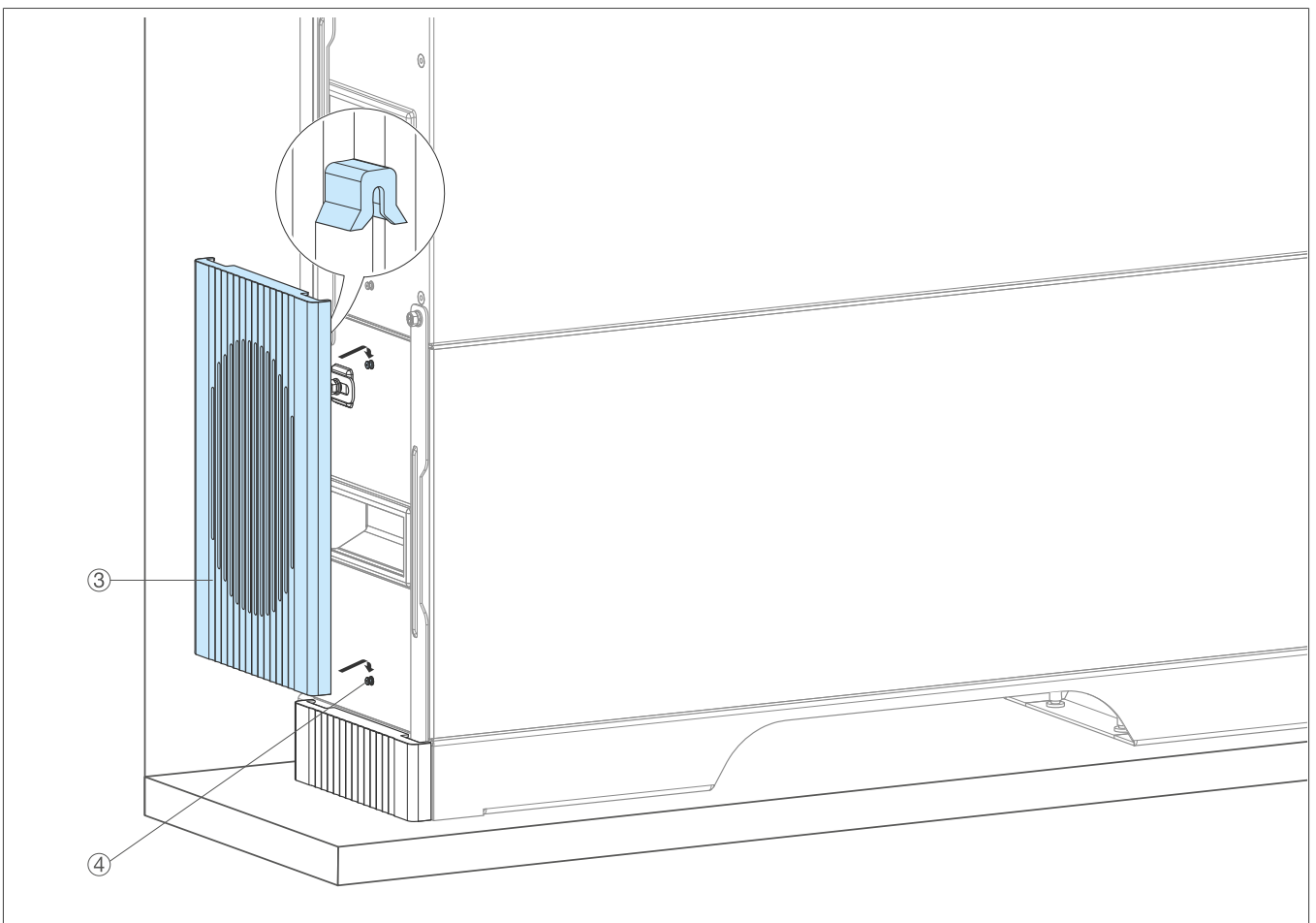

Fig. 26: Install the battery cover

- 4 Before installing the cover panel on the BMS, attach the PE cable to the earthing connection (Connect the PE cable).



### Note

The PE cable can be connected to the left or right side of the BMS.

- 5 Install the cover panel (6) and route the PE cable through the rear recess.
- 6 Fasten the BMS cover panel using two M5 × 12 combination screws (5).

The installation of the battery modules and the BMS has been completed.

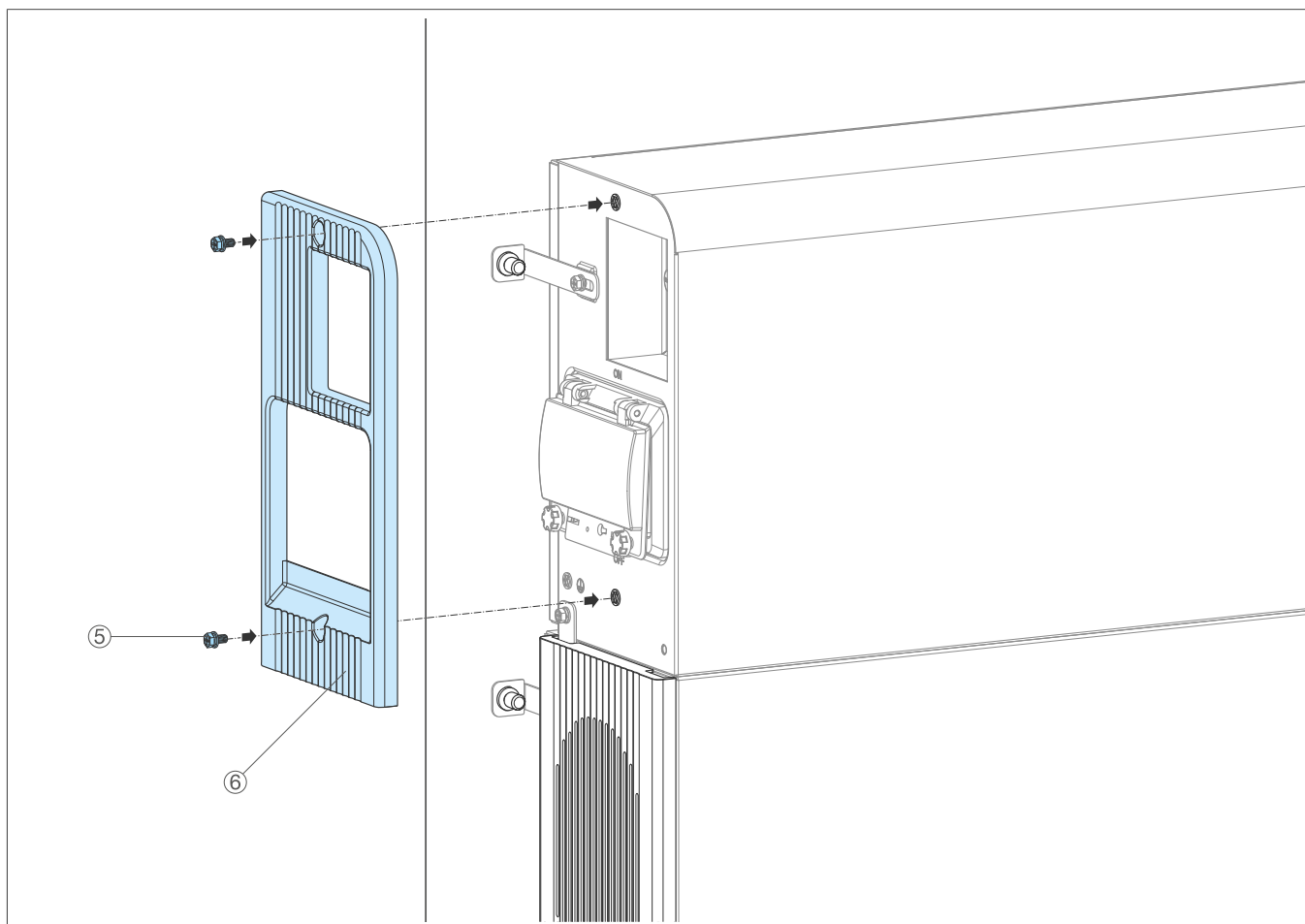

Fig. 27: Install the BMS cover panel

## 3 Install battery modules and BMS

### 3.1 Safety instructions



#### Danger

Electric shock when touching live parts!

An electric shock can lead to death!

- Before working on the device, disconnect the cables and secure them against reconnection. Verify that the device is voltage free, earth and short circuit it, and cover any nearby live parts.
- Disable or switch off emergency power mode.
- Before opening the device, turn the DC disconnect switch and the battery management system (BMS) main switch to the **OFF** position. Be sure to remove the DC plugs.
- Do not switch off the DC voltage by disconnecting the DC plugs only. Otherwise, there is a risk of arcing.
- All applicable safety regulations, the technical connection requirements (TAB) of the responsible energy supply company and the VDE regulations must be observed when installing and operating the device.
- Calculate and provide the necessary protection for cables and personnel.



#### Danger

Danger to life due to electrical voltage!

Energised parts can cause serious injuries.

- Read and observe all the printed information provided, as well as the technical documentation available online before working on the battery modules.
- Do not install battery storage system in areas where flooding may occur!
- Do not install the battery storage system in a location with high humidity.
- Reduce dust contamination to a minimum.
- Set the main switch in the BMS to the OFF position.
- Wear safety glasses and protective gloves when working on the battery modules.
- Drop off conductive jewelry such as watches, bracelets and rings.



#### Note

All cables used are equipped with polarity-protected plugs.

---

The cable colours shown may differ from the original colours of the cables.

### 3.2 Connecting the battery modules together

If the battery modules and the BMS have been installed correctly, all electrical connections will be completed automatically.

### 3.3 Installing the BMS

#### 3.3.1 Connect the PE cable

The PE cable serves as equipotential bonding between the BMS and the flow enclosure.



#### Note

The PE cable must be installed on site. It must have a cross-section of at least 6 mm<sup>2</sup> and be connected to an earthing point either in the house or on the device.

- 1 Make sure that the main switch of the BMS is in the **OFF** position (see [Installing the battery modules and BMS](#)).
- 2 Screw the PE cable (3) to the left or right side of the BMS with 3 Nm using an unpainted M 5 x 12 screw.
- 3 Connect the other end of the PE cable to an earthing point in the house or on the device.

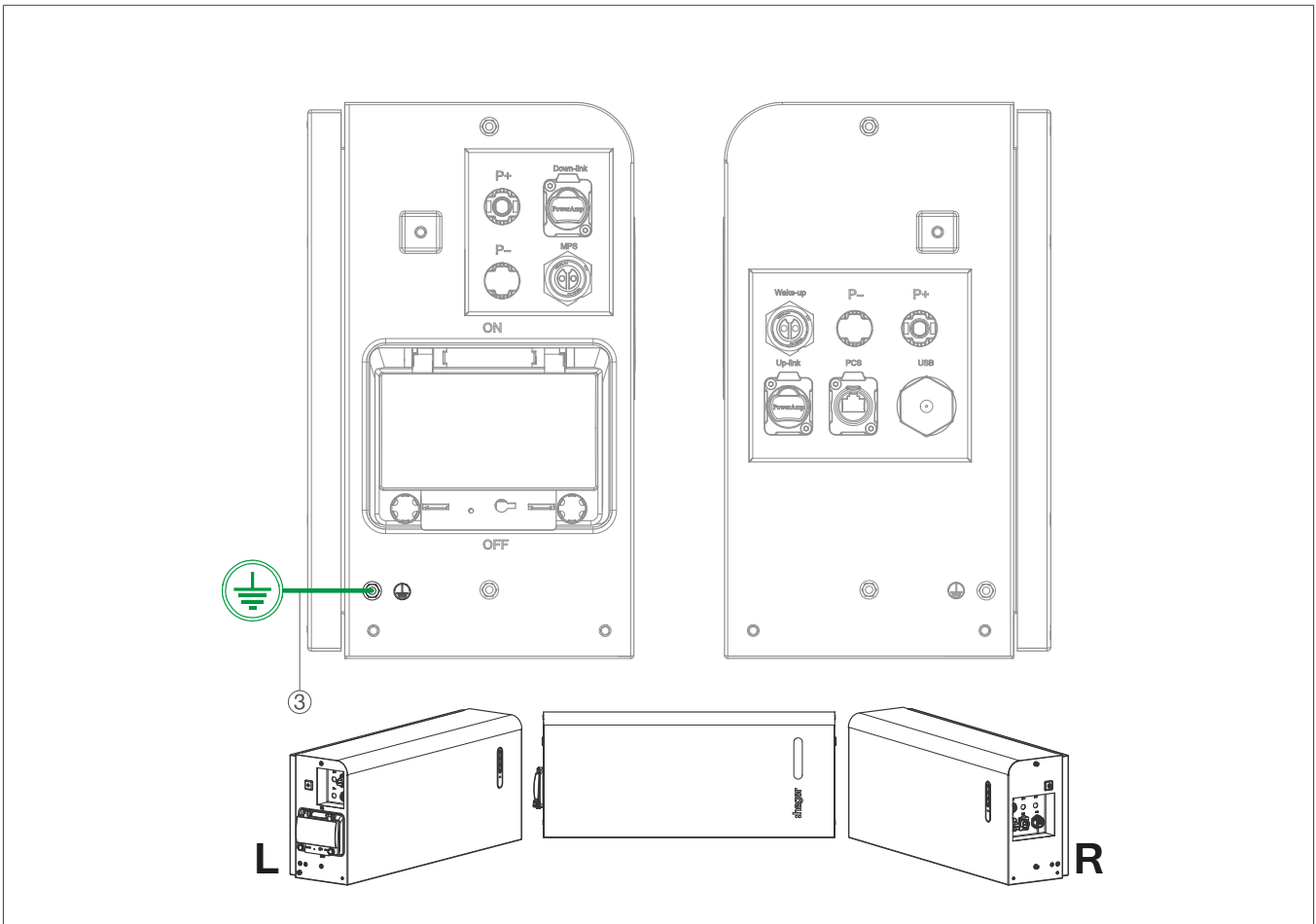

Fig. 28: Connect the PE cable

**3.3.2 Installation on a stackable battery system**

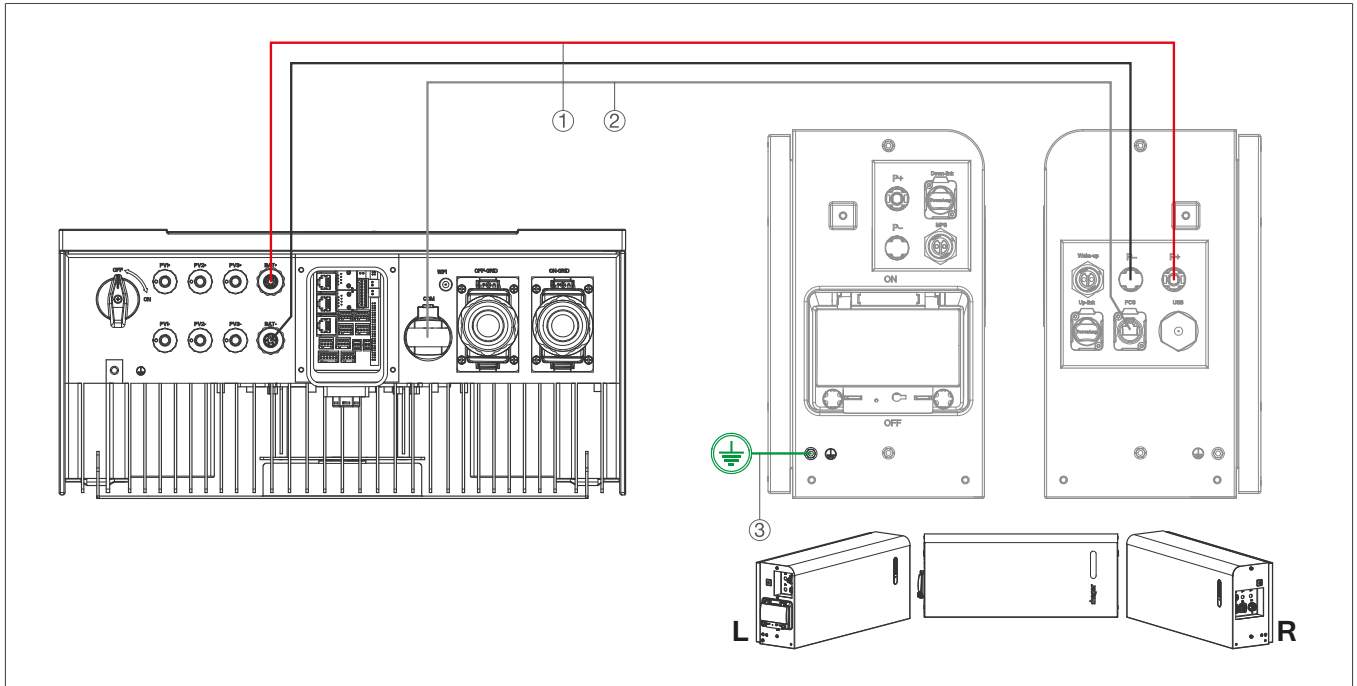
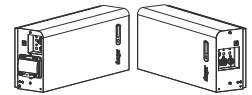
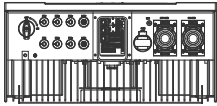

Fig. 29: Installing on a stackable Battery System (Diagram)

**Procedure**



**Inverter**

**Cable designation**

**BMS**

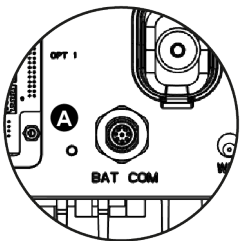

Bottom device

① Kommunikationsleitung BE-K1414

- Connect the **SYSTEM COM** plug to the **BAT-COM** socket (A) on the device.
- Insert the **HVB-S\_PCS** plug into the **PCS** socket (D) on the right-hand side of the BMS.

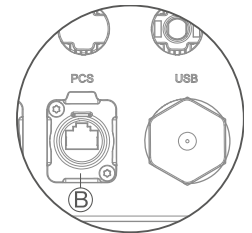

BMS, right side

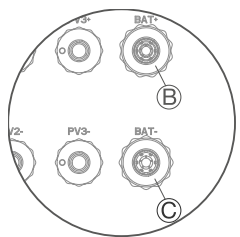

Bottom device

② Batterieleitung BE-K1416

- Insert the red **SYS PLUS (B+)** plug into the **BAT +** socket (B) on the device.
- Insert the blue plug **SYS MINUS (B-)** into the socket **BAT -** (C) on the device.
- Insert the red **HVB-S\_(P+)** plug into the **P+** socket (E) on the right-hand side of the BMS.
- Insert the blue **HVB-S\_(P-)** plug into the **P-** socket (F) on the right-hand side of the BMS.

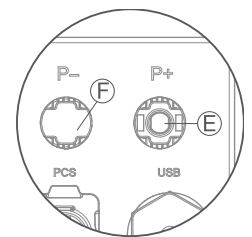

BMS, right side

①	Battery cable (BE-K1416) <a href="#">see Battery cable (BE-K1416)</a>	1
②	Communication cable (BE-K1414) <a href="#">see Communication cable (BE-K1414)</a>	1

Table 8: Overview of cable connections for a stackable battery system

### 3.3.3 Retrofitting of battery modules

Up to 6 battery modules can be controlled with a BMS. By retrofitting a second stackable battery system, up to 6 additional battery modules can be connected. Note that both stackable battery systems must contain the same number of battery modules.

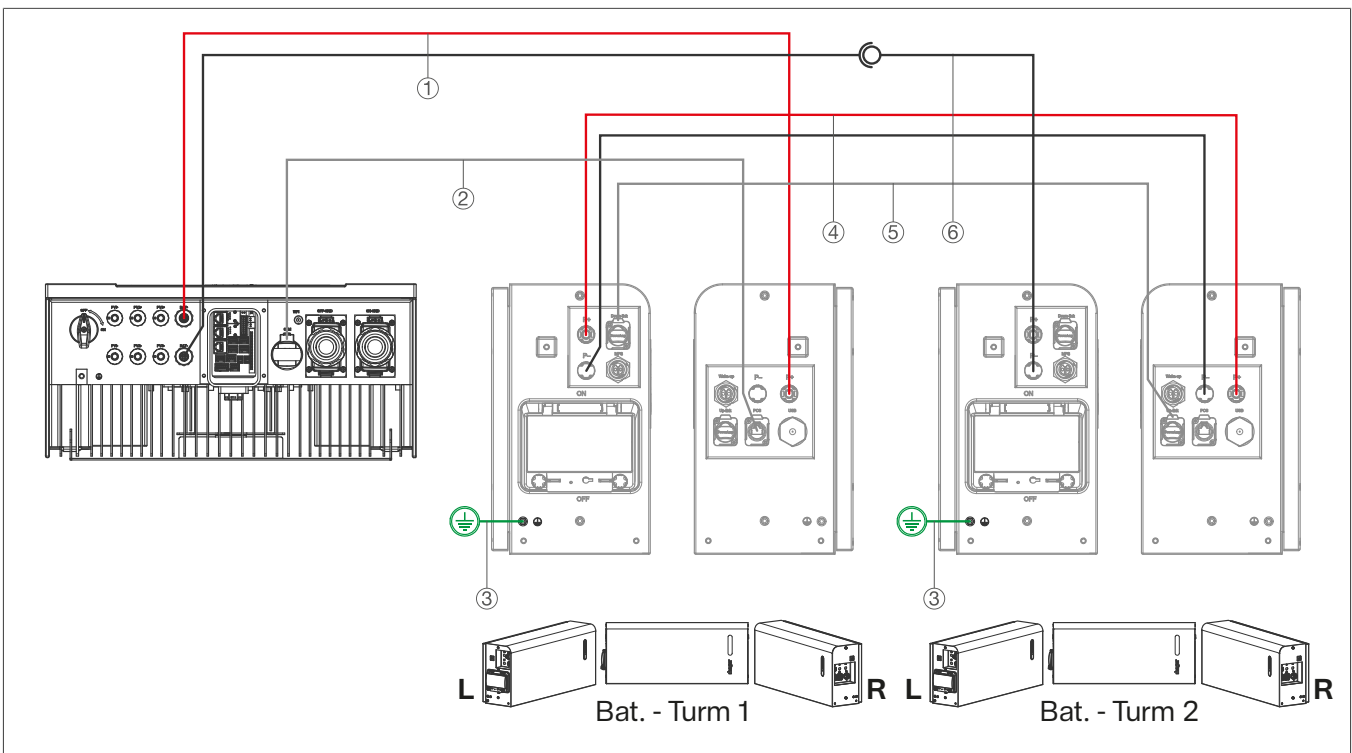
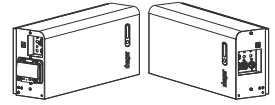
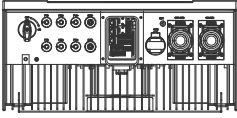

Fig. 30: Retrofitting of battery modules

**Procedure**



**Inverter**

**Cable designation**

**BMS**

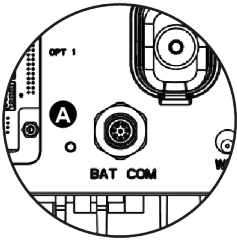

Bottom device

- ② Communication cable BE-K1414
- Connect the **SYSTEM COM** plug to the **BAT-COM** socket (A) on the device.
- Insert the **HVB-S\_PCS** plug into the **PCS** socket (D) on the right-hand side of the BMS.

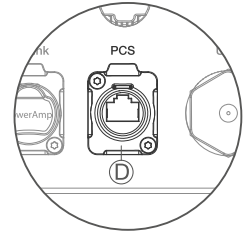

BMS, right side

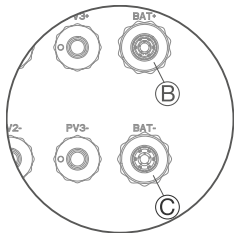

Bottom device

- ① Battery cable BE-K1416
- Insert the red **SYS PLUS (B+)** plug into the **BAT +** socket (B) on the device.
- Insert the blue **SYS MINUS** plug (B-) into the **BAT -** socket (C) on the device.
- On the stackable battery system 1, insert the red plug **HVB-S\_(P+)** into the socket **P+** (E) on the right-hand side of the BMS.

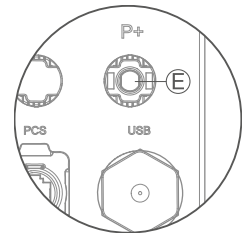

BMS Right Side (stackable Battery System 1)



- ⑥ Battery cable BE-K1425
- Use the BE-K1425 battery cable to extend the negative terminal of the BE-K1416 battery cable (1).
- On the stackable battery system 2, insert the black **HVB-S (P-)** plug into the **P-** socket (G) on the left-hand side of the BMS.

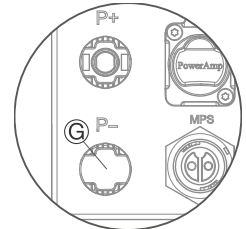

BMS Left Side (stackable Battery System 2)

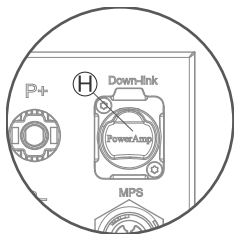

BMS Left Side (stackable Battery System 1)

- ⑤ Communication cable BE-K1423
- Insert the **HVB-S\_Down-link** plug into the **Down-link** socket (H) on the left-hand side of stackable battery system 1.
- Insert the **HVB-S\_Up-link** plug into the **Up-link** socket (I) on the right-hand side of the stackable battery system 2.

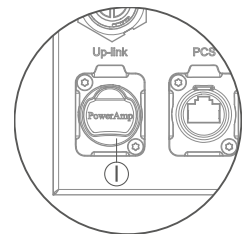

BMS Left Side (stackable Battery System 2)

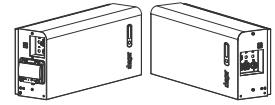
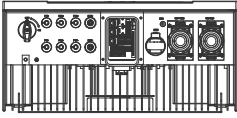

### Inverter

### Cable designation

### BMS

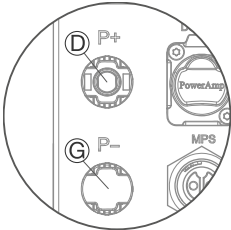

BMS Left Side (stackable Battery System 1)

- ④ Battery cable BE-K1424
  - On the left-hand side of the stackable battery system 1, insert the **HVB-S (P+)** plug into the **P+** socket (D).
  - On the left-hand side of the stackable battery system 1, insert the **HVB-S** plug (**P-**) into the **P-** socket (G).
  - On the right side of the stackable battery system 2, insert the **HVB-S (P+)** plug into the **P+** socket (E).
  - On the right side of the stackable battery system 2, insert the **HVB-S** plug(**P-**) into the **P-** socket (F).

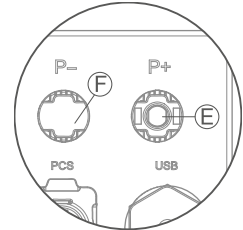

BMS Right Side (stackable Battery System 2)

①	Battery cable (BE-K1416) <a href="#">see Battery cable (BE-K1416)</a>	1
②	Communication cable (BE-K1414) <a href="#">see Communication cable (BE-K1414)</a>	1
③	PE cable (to be installed by the customer)	Number of BMS
④	Battery cable (BE-K1424) <a href="#">see Cable set (BE-K1426)</a>	Number of stackable battery systems minus 1
⑤	Communication cable (BE-K1423) <a href="#">see Cable set (BE-K1426)</a>	Number of stackable battery systems minus 1
⑥	Battery cable (BE-K1425) <a href="#">see Cable set (BE-K1426)</a>	1

Table 9: Overview of cables for two stackable battery systems

### 3.4 Switch on BMS

Set the main switch (1) of the BMS to the **ON** position. For systems with multiple stackable battery systems, each BMS must be switched on via the main switch.

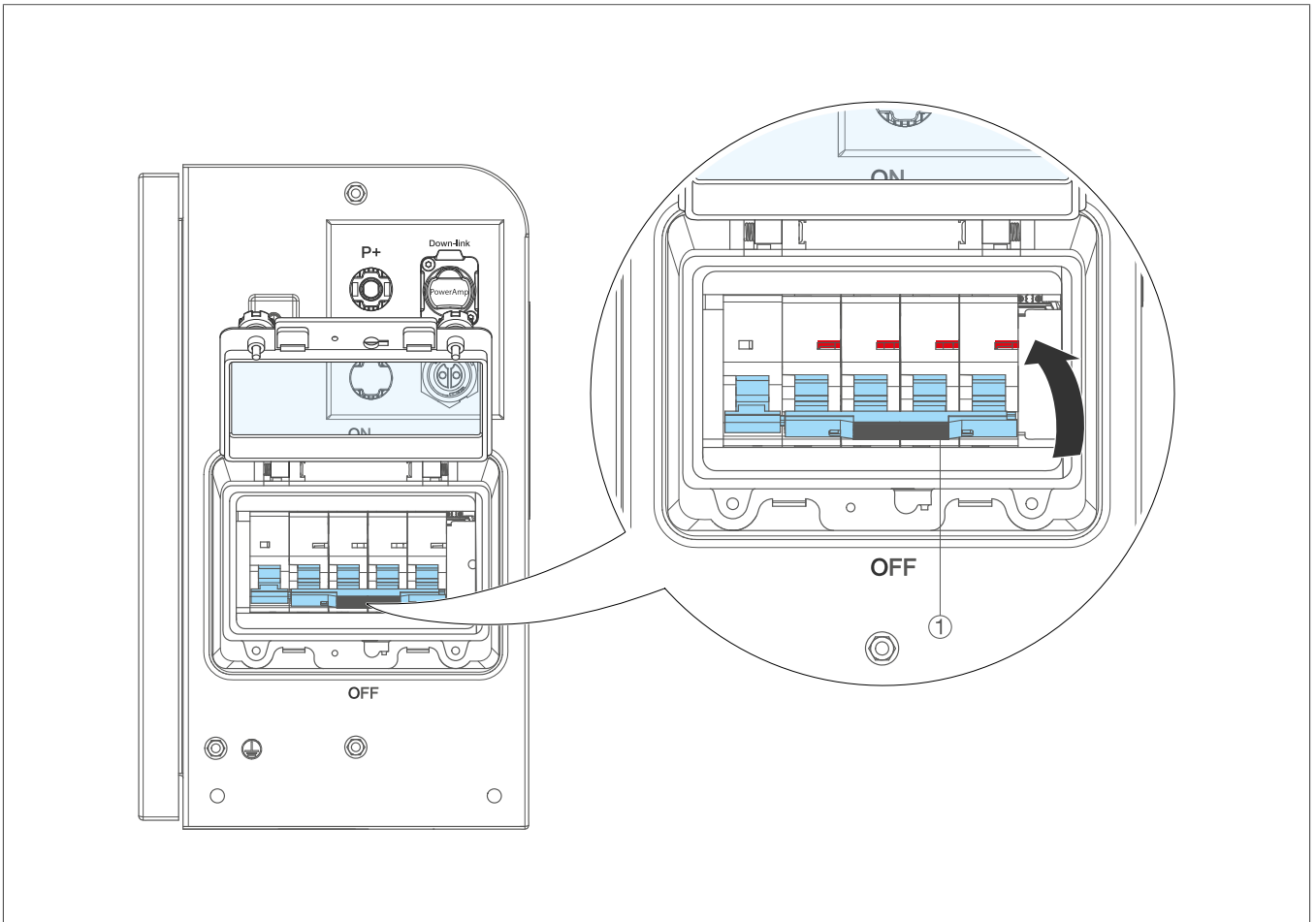

Fig. 31: Switching on the BMS (see image)

### 3.5 Display of the battery status on the BMS

#### 3.5.1 Battery level

After connecting the battery modules and switching on the BMS, LEDs on the BMS indicate the status of the battery modules.

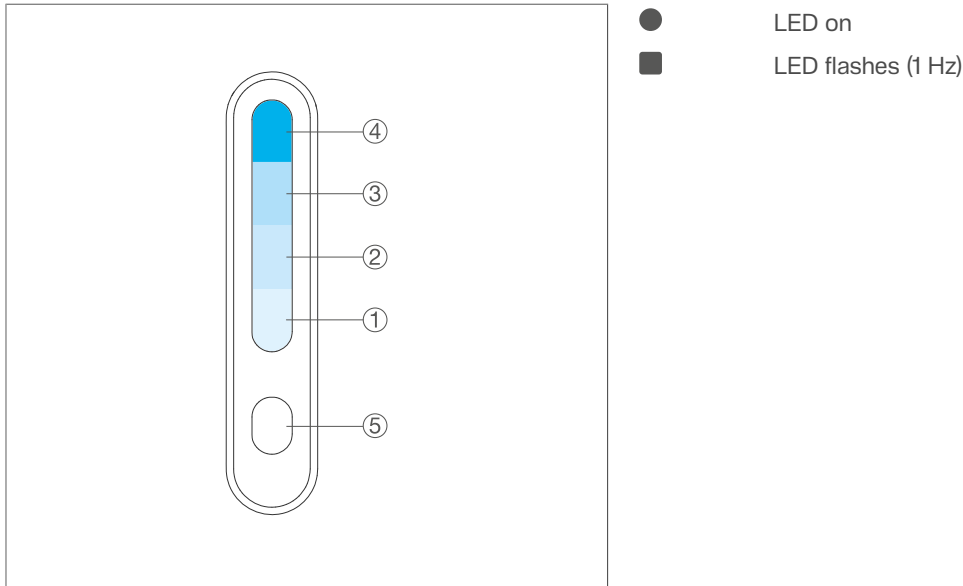

Fig. 32: LED indicator for battery charge level

System status	Charge level	LED (4)	LED (3)	LED (2)	LED (1)	LED (5) (blue/red)
Charge	0-25.0%				■	●
	25.1-50.0%			■	■	●
	50.1-75.0%		■	■	■	●
	75.1-99.9%	■	■	■	■	●
	100%	●	●	●	●	●
Discharging and stand-by	100-75.1%	●	●	●	●	●
	75.0-50.1%		●	●	●	●
	50.0-25.1%			●	●	●
	25.0-0%				●	●

i

**Note**

The battery charge level (SOC) can be viewed in the customer portal or in the app on mobile devices.

#### 3.5.2 Error codes

After connecting the battery modules and switching on the BMS, LEDs on the BMS indicate the status of the battery modules.

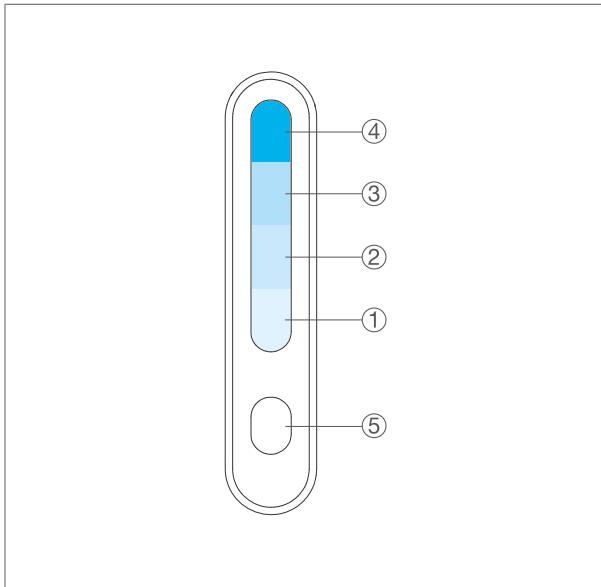

- LED on
- ◆ LED flashes rapidly (2 Hz)
- ★ LED flashes rapidly (4 Hz)

Fig. 33: LED display for error codes

System status	System information	LED (4)	LED (3)	LED (2)	LED (1)	LED (5) (blau/rot)
Remote		-	-	-	-	-
Boot load		★	★	★	★	★
Start	Master/slave	◆	◆	◆	◆	●
		◆	-	-	-	●
		-	◆	-	-	●
		◆	◆	-	-	●
		-	-	◆	-	●
		◆	-	◆	-	●
		-	◆	◆	-	●
		◆	◆	◆	-	●
Check the battery system configuration	Check completed successfully	SOC display**				◆
	Permanent monitoring	SOC display**				◆
Error	Overvoltage	●	-	-	-	●
	Undervoltage	-	●	-	-	●
	Above the permitted temperature range	●	●	-	-	●
	Below the permitted temperature range	-	-	●	-	●
	Overcurrent	●	-	●	-	●
	SOH too low	-	●	●	-	●
	Internal communication error	●	●	●	-	●

System status	System information	LED (4)	LED (3)	LED (2)	LED (1)	LED (5) (blau/rot)
	External communication error	-	-	-	●	●
	Parallel ID error	●	-	-	●	●
	Serial ID error	-	●	-	●	●
	HV BOX fuse	●	●	-	●	●
	Module fuse	-	-	●	●	●
	Contact error	●	-	●	●	●
	Isolation control error	-	●	●	●	●
	BMS error	●	●	●	●	●

## 4 Retrofitting individual battery modules

### 4.1 Measuring the voltage of the retrofitted battery modules

It is necessary to adjust the voltage of the already existing battery modules with the voltage of the battery modules to be retrofitted. The battery voltage must be adjusted before retrofitting battery modules.

☑ The lower module input connector and the upper module output connector must be freely accessible for measurement.

- ① Hold the first multimeter probe tip against **pin A (1)** on the top of the battery module.
- ② Hold the second multimeter probe tip against **pin A (2)** on the bottom of the battery module.
- ③ Read the value on the multimeter and write it down.

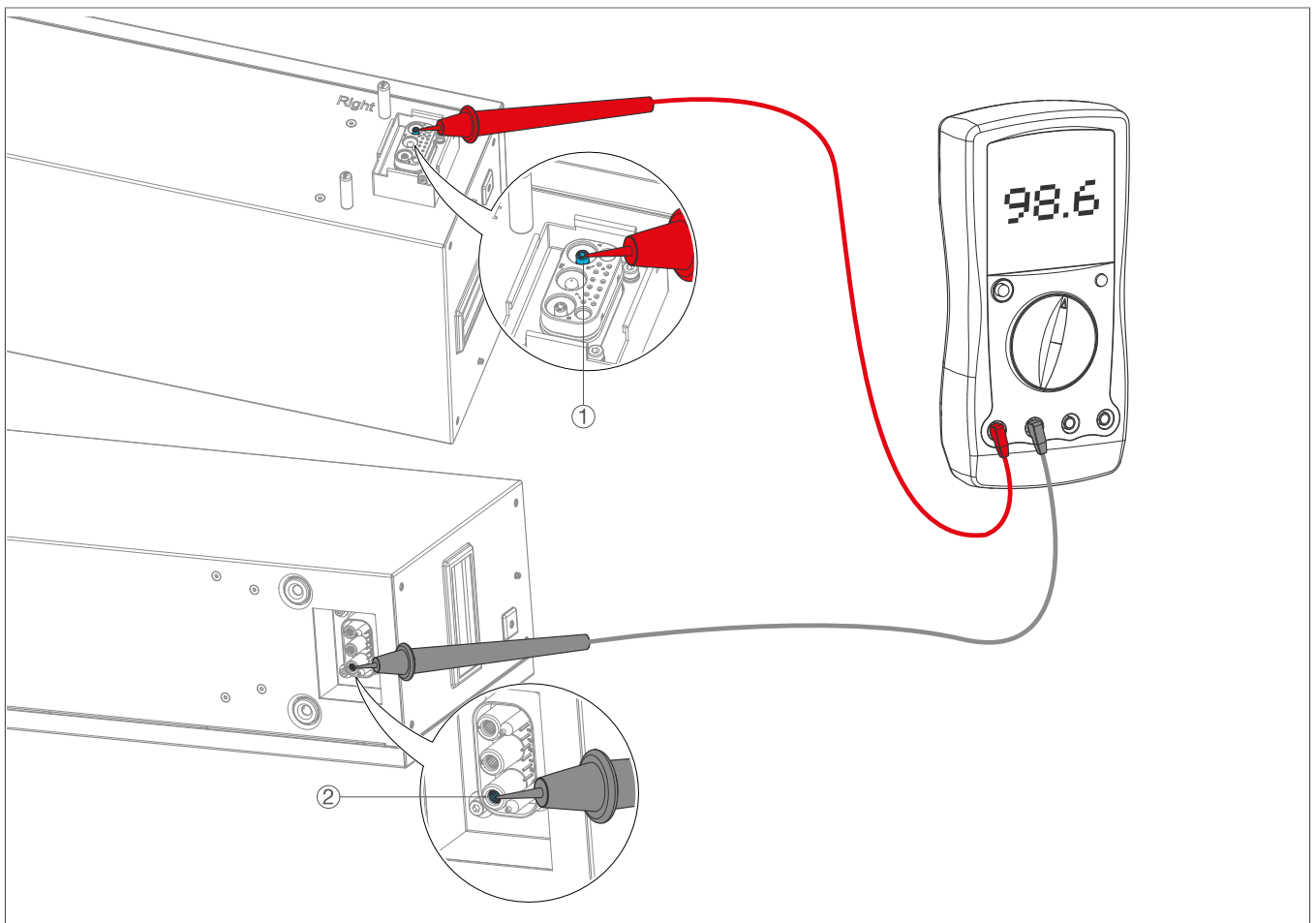

Fig. 34: Measure the battery voltage

- ④ If you are retrofitting multiple battery modules, calculate the average of all the measured voltages.



#### Note

If the battery voltages are not measured, a flat-rate voltage value must be applied when adjusting the battery voltages. This may result in a balancing phase of several months, which can lead to lower charging capacities.

## 4.2 Battery voltages of existing battery modules

The voltages of the existing battery modules must be adjusted to the voltage of the existing retrofitted battery modules.



For this procedure, refer to the document **Adjusting the battery voltage before retrofitting existing batteries**, see [flow.hager.com/documents](https://flow.hager.com/documents) (registration required).

## 4.3 Installing new battery modules

- ☑ The voltage of the new battery modules has been measured.
- ☑ The voltage has been adjusted.
- ☑ The device is voltage-free.
- ☑ All cables are disconnected from the BMS.
- ☑ The wall brackets of the BMS and the top connecting rails are removed.

- 1 Lift the BMS (1) off the battery module (2) and set it aside.

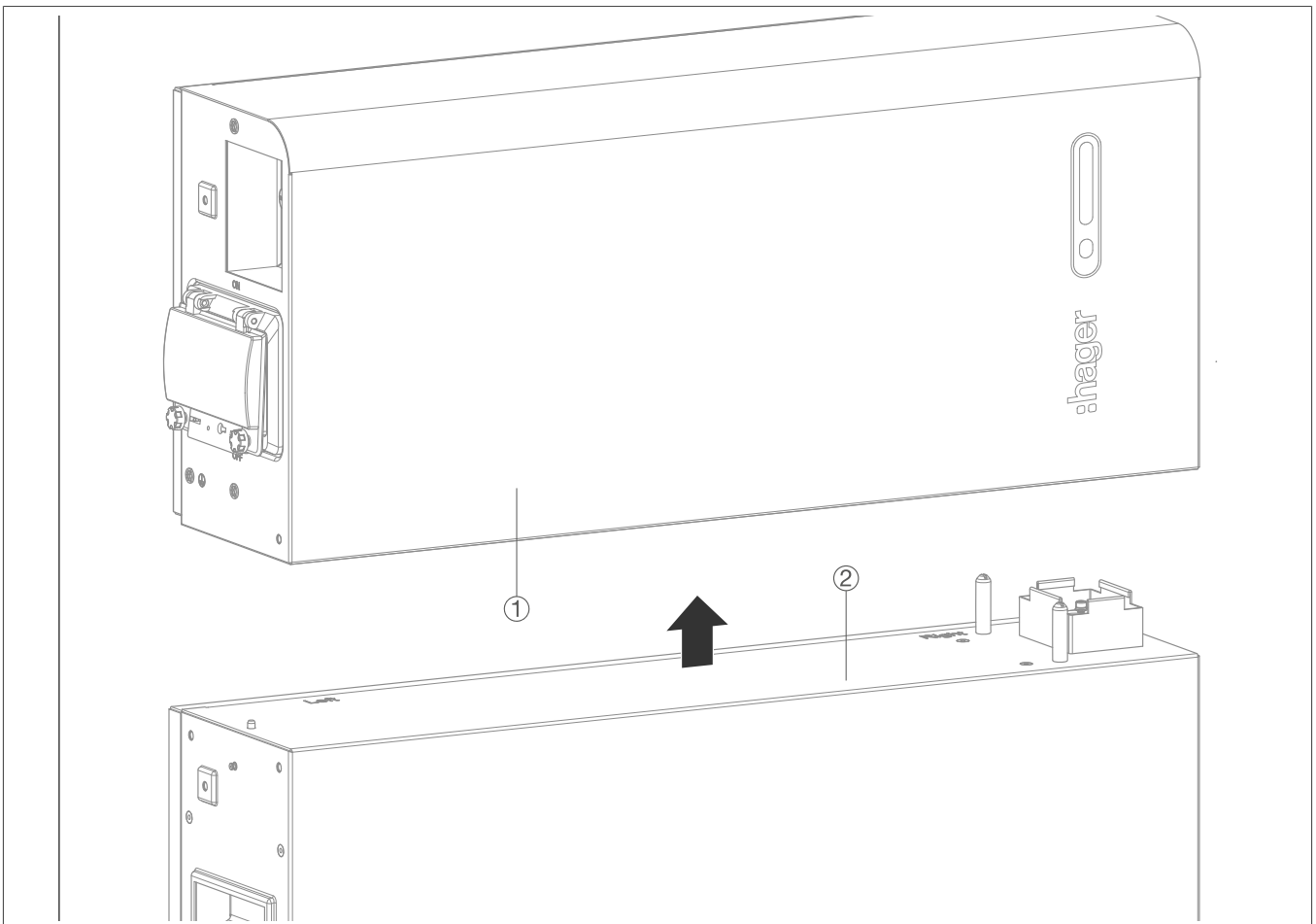

Fig. 35: Remove the BMS

- 2 Place the new battery module(s) on the top of the existing battery module.
  - 3 Place the BMS on the last battery module.
  - 4 Install the battery modules and the BMS as described in [Installing the battery modules and BMS](#).
- The installation of the new battery modules is complete.



**HagerEnergy GmbH**

Ursula-Flick-Straße 8

49076 Osnabrück

Germany

+49 541 7602680

info@hager.com

**hager.com**