

JNP201MID

Installation instructions

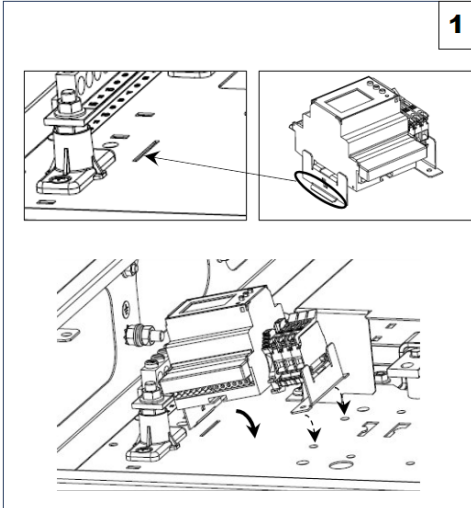

ZD0946



Offer meter/bracket up to the chassis plate, engaging the tab into the slot on the chassis as shown.

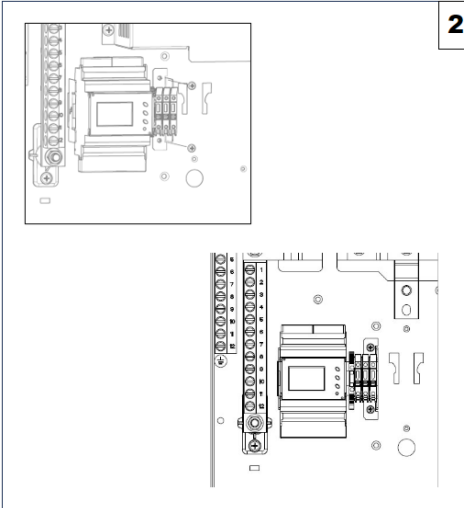

Securing the bracket and meter assembly with 2 x M4 screw.

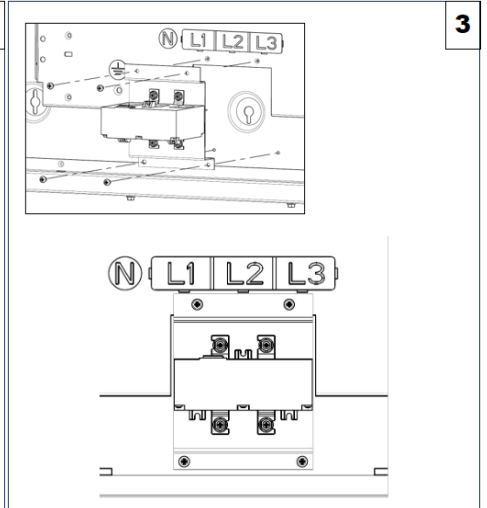

Align the CT & bracket assembly to the main board chassis as shown and secure using 2 x M4 screw for the top fixings and 2 x self-tapping screw to the bottom fixing holes.

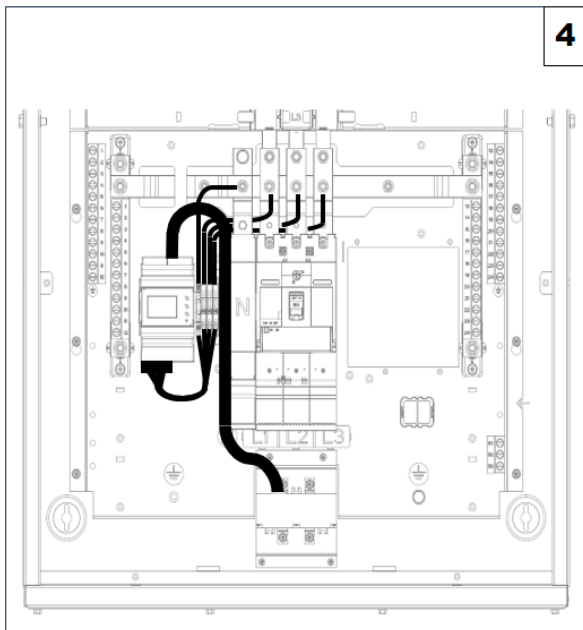

Fit cables from fuse pack to phase links using 1 x M6 nut & bolt per cable and tighten to 5Nm. Fit wire loom from the bottom of the fuse pack to the bottom of the meter. Connect the data cable from the top of the meter and into the CT, ensuring the "click" sound confirms cable security.

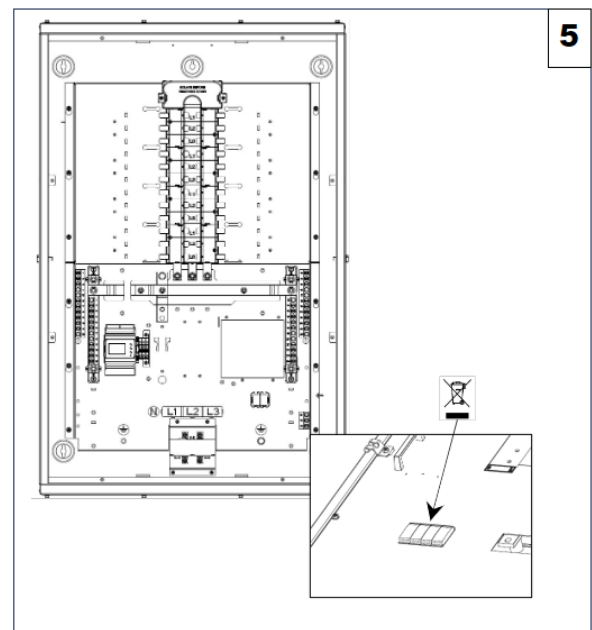

Replace all covers, (remembering to remove 4 x blank from main cover) and the door to complete fitting of the meterpack.

ZD0946

The device may only be connected and installed by an electrically skilled person. National standards and safety regulations must be observed. The device must be checked for external damage prior to installation. If any damage or other defects are detected in this check, the device must not be installed.

Its use is only permitted within the limits shown and stated in the installation instructions. Opening or otherwise tampering with the device invalidates the warranty.